

TM 5-2420-224-20-2
Volume No. 2

TECHNICAL MANUAL
UNIT MAINTENANCE MANUAL
FOR
TRACTOR, WHEELED, 4 X 4 DED
SMALL EMPLACEMENT EXCAVATOR (SEE)
(NSN 2420-01-160-2754) (EIC:EDL)

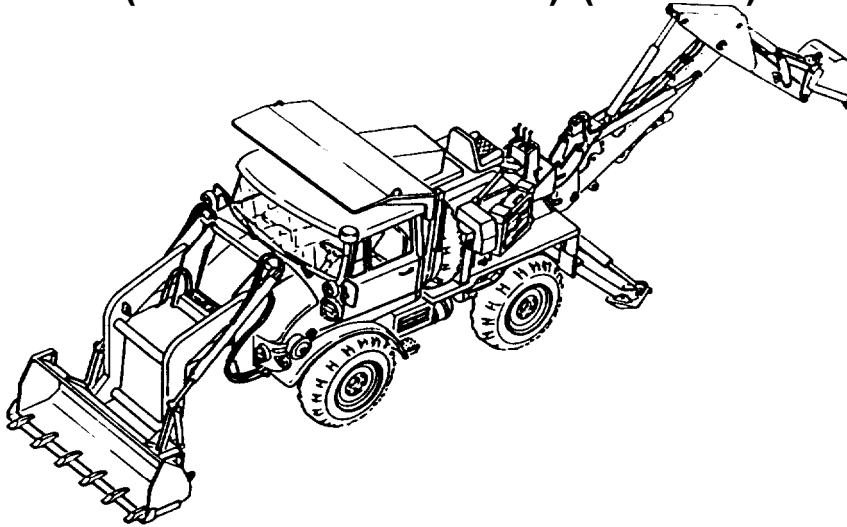

TRACTOR, WHEELED, 4 X 4 DED
HIGH MOBILITY MATERIAL HANDLER (HMMH)
(NSN 2420-01-205-8636)

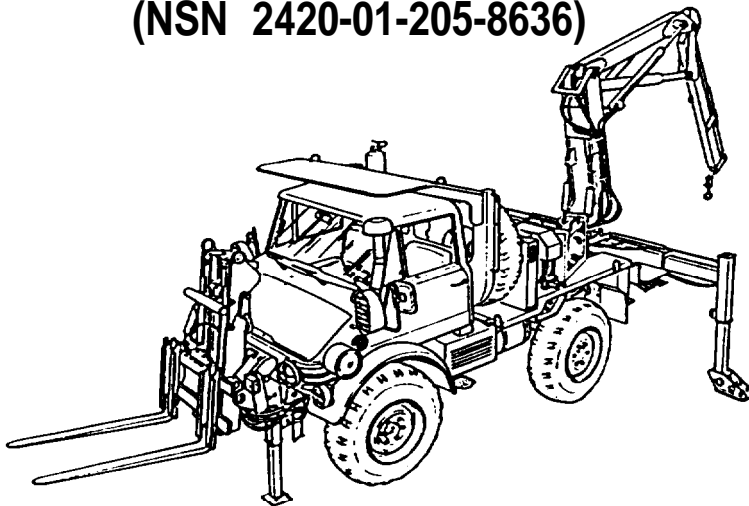

TABLE OF CONTENTS

I

**VEHICLE MAINTENANCE
INSTRUCTIONS**

4-1

REFERENCES

A-1

**MAINTENANCE
ALLOCATION CHART**

B-1

**EXPENDABLE SUPPLIES
AND MATERIALS LIST**

C-1

**ILLUSTRATED LIST
OF MANUFACTURED
ITEMS**

D-1

INDEX

Index-1

HEADQUARTERS, DEPARTMENT OF THE ARMY

28 JULY 1993

This manual along with TM5-2420-224-20-1 and TM5-2420-224-34 supersedes

TM5-2420-224-24 dated December 1989

Approved for public release: distribution is unlimited.

WARNING

CARBON MONOXIDE POISONING CAN BE DEADLY

CARBON MONOXIDE IS A COLORLESS, ODORLESS, DEADLY POISONOUS GAS, WHICH, WHEN BREATHED, DEPRIVES THE BODY OF OXYGEN AND CAUSES SUFFOCATION. EXPOSURE TO AIR CONTAMINATED WITH CARBON MONOXIDE PRODUCES SYMPTOMS OF HEADACHE, DIZZINESS, LOSS OF MUSCULAR CONTROL, APPARENT DROWSINESS, OR COMA. PERMANENT BRAIN DAMAGE OR DEATH CAN RESULT FROM SEVERE EXPOSURE.

CARBON MONOXIDE OCCURS IN THE EXHAUST FUMES OF FUEL-BURNING HEATERS AND INTERNAL-COMBUSTION ENGINES AND BECOMES DANGEROUSLY CONCENTRATED UNDER CONDITIONS OF INADEQUATE VENTILATION. THE FOLLOWING PRECAUTIONS MUST BE OBSERVED TO ENSURE THE SAFETY OF PERSONNEL WHENEVER THE PERSONNEL HEATER, MAIN, OR AUXILIARY ENGINE OF ANY VEHICLE IS OPERATED FOR MAINTENANCE PURPOSES OR TACTICAL USE:

1. DO NOT operate engine of vehicle in an enclosed area unless it is ADEQUATELY VENTILATED.
2. DO NOT idle engine for long periods without maintaining ADEQUATE VENTILATION in the personnel compartments.
3. DO NOT drive any vehicle with inspection plates, cover plates, or engine compartment doors removed unless necessary for maintenance purposes.
4. BE ALERT at all times during vehicle operation for exhaust odors and exposure symptoms. If either is present, IMMEDIATELY VENTILATE personnel compartments. If symptoms persist, remove affected personnel from vehicle and treat as follows: expose to fresh air; keep warm, DO NOT PERMIT EXERCISE; if necessary, administer artificial respiration (see FM 21-11).

THE BEST DEFENSE AGAINST CARBON MONOXIDE POISONING IS ADEQUATE VENTILATION.

WARNING

COMPRESSED AIR

To prevent injury, compressed air used for cleaning and drying purposes will not exceed 30 psi (207 Kpa). Use only with effective chip guarding and personal protective equipment (goggles/shield, gloves, etc.).

WARNING

Drycleaning solvent P-D-680 is toxic and flammable. Wear protective goggles and gloves and use only in well-ventilated area. Avoid contact with skin, eyes, and clothes and do not breathe vapors. Do not use near open flame or excessive heat. Flash point is 100°-138° F (38°-50°C). If you become dizzy while using drycleaning solvent, get fresh air immediately and 'get medical aid. If contact with eyes is made, wash your eyes with water and get medical aid immediately.

WARNING

Remove rings, bracelets, wristwatches, and neck chains before working on vehicle. Jewelry can catch on equipment and cause injury, or may short across an electrical circuit and cause severe burns or electrical shock.

WARNING

Allow engine to cool before performing maintenance on the muffler, exhaust pipe, or exhaust manifold. If necessary, use insulated pads and gloves.

WARNING

Remove or disconnect batteries and turn vehicle MASTER disconnect switch OFF prior to performing maintenance in immediate battery area or working on electrical system. Such disconnections prevent electrical shock to personnel or equipment.

WARNING

Diesel fuel is flammable. Do not perform this procedure near fire, flame, or sparks. Injury or death to personnel could result.

WARNING

Lead-acid battery gases can explode. Do not smoke, have open flames, or make sparks around a battery, especially if caps are off. If a battery is gassing, it can explode and cause injury to personnel.

WARNING

Battery acid (electrolyte) is extremely harmful. Always wear safety goggles and rubber gloves, and do not smoke when performing maintenance on batteries. Injury will result if acid contacts skin or eyes. Wear rubber apron to prevent clothing being damaged.

WARNING

Do not work on cold start aid system in presence of sparks or open flame. To do so could result in injury to personnel.

WARNING

Do not connect or disconnect any electrical connector unless vehicle MASTER disconnect switch is OFF. To do so could result in injury to personnel.

WARNING

Do not disconnect any air system lines or fittings unless vehicle engine is shut off and air system pressure is relieved. To do so could result in injury to personnel.

WARNING

All vehicle electrical switches must be OFF before disconnecting battery cables. Failure to do so could result in injury to personnel.

WARNING

Batteries weigh 71 pounds (32 kilograms). To avoid personal injury, use a hoist or suitable lifting device when lifting batteries.

W A R N I N G

Fuel tank weighs 58 pounds (26 kilograms). To avoid personal injury, use a hoist or suitable lifting device when lifting fuel tank.

W A R N I N G

Make sure parking brake is set and that wheels not being lifted are blocked. Failure to do so could result in serious injury to personnel.

W A R N I N G

Wheel assembly weighs 170 pounds (77 kilograms). To avoid personal injury, use a hoist or suitable lifting device when lifting wheel assembly.

W A R N I N G

High pressure hydraulics [oil under 2450 psi (16,893 kPa)] operate this equipment. Never disconnect any hydraulic line or fitting without first dropping pressure to zero. A high pressure oil stream can pierce body and cause severe injury to personnel.

W A R N I N G

Loader boom cylinder weighs 83 pounds (38 kilograms). To avoid personal injury, use a hoist or suitable lifting device when lifting loader boom cylinder.

W A R N I N G

Backhoe boom cylinder weighs 83 pounds (38 kilograms). To avoid personal injury, use a hoist or suitable lifting device when lifting backhoe boom cylinder.

W A R N I N G

Loader bucket rollback cylinder weighs 40 pounds (18 kilograms). To avoid personal injury, use a hoist or suitable lifting device when lifting loader bucket rollback cylinder.

WARNING

Fuel and oil are slippery and can cause falls. To avoid injury, wipe up spilled fuel or oil with rags.

WARNING

Backhoe dipper cylinder weighs 107 pounds (49 kilograms). To avoid personal injury, use a hoist or suitable lifting device when lifting backhoe dipper cylinder.

WARNING

Backhoe stabilizer cylinder weighs 77 pounds (35 kilograms). To avoid personal injury, use a hoist or suitable lifting device when lifting backhoe stabilizer cylinder.

WARNING

Canopy weighs 260 pounds (118 kilograms). To avoid personal injury, use a hoist or suitable lifting device when lifting canopy.

WARNING

Hydraulic accessory box (SEE) weighs 94 pounds (43 kilograms); (HMMH) weighs 110 pounds (50 kilograms). To avoid personal injury, use a hoist or suitable lifting device when lifting hydraulic accessory box.

WARNING

Front hydraulic tank assembly weighs 98 pounds (45 kilograms). To avoid personal injury, use a hoist or suitable lifting device when lifting front hydraulic tank assembly.

WARNING

Hydraulic oil cooler weighs 85 pounds (39 kilograms). To avoid personal injury, use a hoist or suitable lifting device when lifting hydraulic oil cooler.

WARNING

Make sure parking brake is set and that wheels are blocked. Failure to do so could result in injury to personnel.

WARNING

Large air pressure tank weighs 30 pounds (14 kilograms) and small air pressure tank weighs 25 pounds (12 kilograms). To avoid personal injury, use a hoist or suitable lifting device when lifting air pressure tank.

WARNING

Backhoe stabilizer weighs 140 pounds (64 kilograms). To avoid personal injury, use a hoist or suitable lifting device when lifting backhoe stabilizer.

WARNING

Never inspect, clean, or replace chain or bar with operating pressure at tool. To do so could result in injury to personnel.

WARNING

Chain cutters are sharp. Wear protective gloves when removing, installing, or adjusting chain. Failure to do so could result in injury to personnel.

WARNING

Support cab during removal and installation of spacers. Failure to do so could result in serious injury to personnel.

WARNING

Cab weighs in excess of 618 pounds (281 kilograms). Use suitable lifting device when lifting or tilting cab. Failure to do so could result in injury to personnel.

WARNING

Backhoe bucket cylinder weighs 83 pounds (38 kilograms). To avoid personal injury, use a hoist or suitable lifting device when lifting backhoe bucket cylinder.

WARNING

Antifreeze fluid is extremely flammable. Do not work on antifreeze system in presence of sparks or open flame. To do so could result in injury to personnel.

WARNING

Support drag link during removal. Drag link end could drop causing personnel injury.

WARNING

Crane mast locking cylinder weighs 117 pounds (53 kilograms). To avoid personal injury, use a hoist or suitable lifting device when lifting crane mast locking cylinder.

WARNING

Crane external end extension cylinder weighs 169 pounds (77 kilograms). To avoid personal injury, use a hoist or suitable lifting device when lifting crane external end extension cylinder.

WARNING

Crane inner boom lift cylinder weighs 219 pounds (100 kilograms). To avoid personal injury, use a hoist or suitable lifting device when lifting crane inner boom lift cylinder.

WARNING

Front loader lift arm weighs 400 pounds (182 kilograms). To avoid personal injury, use a hoist or suitable lifting device when lifting front loader lift arm.

WARNING

Hose reel assembly weighs 125 pounds (57 kilograms). To avoid personal injury, use a hoist or suitable lifting device when lifting hose reel assembly.

WARNING

Backhoe dipper weighs 410 pounds (186 kilograms). To avoid personal injury, use a hoist or suitable lifting device when lifting backhoe dipper.

WARNING

Backhoe dipper must be as low to the ground as possible to prevent possible injury to personnel.

WARNING

Front loader main frame weighs 540 pounds (245 kilograms). To avoid personal injury, use a hoist or suitable lifting device when lifting front loader main frame.

WARNING

Crane outer boom cylinder weighs 219 pounds (100 kilograms). To avoid personal injury, use a hoist or suitable lifting device when lifting crane outer boom cylinder.

WARNING

Crane outrigger leg assembly weighs approximately 65 pounds (30 kilograms). To avoid personal injury, use a hoist or suitable lifting device when lifting crane outrigger leg assembly.

WARNING

To prevent possible injury to personnel, make sure crane is in a three-point stance. If not, crane assembly will swing to either side when hydraulic motor is removed.

W A R N I N G

Forklift face plate weighs 50 pounds (23 kilograms). To avoid personal injury, use a hoist or suitable lifting device when lifting forklift face plate.

W A R N I N G

Do not disconnect any axle vent fittings unless all wheel drive selector valve is closed and air system pressure is relieved. To do so could result in injury to personnel.

W A R N I N G

Forklift fork assembly weighs 212 pounds (96 kilograms). To avoid personal injury, use a hoist or suitable lifting device when lifting forklift fork assembly.

W A R N I N G

Do not disconnect any air system lines unless all wheel drive selector switch is in two wheel drive and air system pressure is relieved. To do so could result in injury to personnel.

W A R N I N G

Make sure wheels are properly chocked to prevent roll off and possible injury to personnel.

W A R N I N G

Before adjusting power steering gear, make sure parking brake is applied and transmission is in NEUTRAL. Failure to do so could result in injury to personnel.

W A R N I N G

Make sure rear axle is properly supported with jack stands. Failure to do so could result in serious injury to personnel.

WARNING

Backhoe swing cylinder weighs 70 pounds (32 kilograms). To avoid personal injury, use a hoist or suitable lifting device when lifting backhoe swing cylinder.

WARNING

Backhoe boom weighs 383 pounds (174 kilograms). To avoid personal injury, use a hoist or suitable lifting device when lifting backhoe boom.

WARNING

Backhoe boom assembly with dipper assembly weighs 1,459 pounds (663 kilograms). To avoid personal injury, use a hoist or suitable lifting device when lifting backhoe boom assembly with dipper assembly.

WARNING

Backhoe swing tower weighs 308 pounds (140 kilograms). To avoid personal injury, use a hoist or suitable lifting device when lifting backhoe swing tower.

WARNING

Backhoe bucket ripper shank assembly weighs 42 pounds (19 kilograms). To avoid personal injury, use a hoist or suitable lifting device when lifting backhoe bucket ripper shank assembly.

WARNING

Support control arm during removal. Failure to do so could result in injury to personnel.

WARNING

Do not work on forklift lift cylinder with load on forks or while anyone is near forklift controls. To do so could result in injury to personnel.

W A R N I N G

Rear hydraulic tank assembly weighs 142 pounds (65 kilograms). To avoid personal injury, use a hoist or suitable lifting device when lifting rear hydraulic tank assembly.

W A R N I N G

If NBC exposure is suspected, all air filter media should be handled by personnel wearing protective equipment. Consult your unit NBC Officer or NBC NCO for appropriate handling or disposal instructions.

W A R N I N G

SEE/HMMH should not be operated with front loader (SEE) or forklift (HMMH) or backhoe (SEE) or crane (HMMH) removed, except in a maintenance facility. When maintenance is required and front loader or forklift or backhoe or crane is removed, never operate SEE/HMMH at speeds greater than 5 mph. Tractor stability and handling characteristics are greatly affected with either front loader or forklift or backhoe or crane removed. This could cause loss of control and injury to personnel or damage to vehicle.

W A R N I N G

Edges of glass may be sharp. To avoid personal injury, wear protective gloves when handling glass.

W A R N I N G

Never use gasoline to clean parts. Gasoline is highly flammable. Serious personal injury could result if fuel ignites during cleaning.

W A R N I N G

Prior to initial use, new, extensively repaired, or altered forklift or crane must be load tested to prevent injury to personnel.

W A R N I N G

Tow bar weighs 120 pounds (55 kilograms). To avoid personal injury, always use two or more personnel to install or remove tow bar.

W A R N I N G

To avoid personal injury, do not allow any part of body to get between tow bar and front loader bucket or forklift.

W A R N I N G

Steam cleaning creates hazardous noise levels and severe burn potential. Eye, skin, and ear protection are required.

W A R N I N G

Solvents used with spray gun must be used in spray booth with filter. Face shield must be used by personnel operating spray gun. Failure to do so could result in serious injury to personnel.

W A R N I N G

Drilling and grinding operations are hazardous to the eyes. Eye protection is required.

W A R N I N G

On direct contact, uncured silicone sealant irritates eyes. In case of contact, flush eyes with water and seek medical attention. Avoid prolonged contact with skin.

W A R N I N G

Before starting engine, make sure all personnel are clear of engine. Failure to do so could result in injury to personnel.

W A R N I N G

When replacing fuses, make sure only fuses of correct amperage are installed. Failure to do so could result in injury to personnel or damage to equipment.

CHANGE

HEADQUARTERS
DEPARTMENT OF THE ARMY
Washington, D.C., 30 March 2004

NO. 2

**UNIT MAINTENANCE MANUAL
FOR
TRACTOR, WHEELED, 4 X 4 DED
SMALL EMPLACEMENT EXCAVATOR (SEE)
(NSN 2420-01-160-2754) (EIC:EDL)**

AND

**TRACTOR, WHEELED, 4 X 4 DED
HIGH MOBILITY MATERIAL HANDLER (HMMH)
(NSN 2420-01-205-8636)**

TM 5-2420-224-20-2, dated 28 July 1993, is updated as follows:

1. File this sheet in front of the manual for reference.
2. New or changed material is indicated by a vertical bar adjacent to the material and/or change designators at bottom of affected page.
3. New or changed illustrations are indicated by a vertical bar adjacent to the illustration or miniature pointing hand adjacent to the updated area.
4. Remove old pages and insert new pages as indicated below.

Remove Pages

A/(B blank)
i and ii
4-7 and 4-8
4-15 and 4-16
4-87 and 4-88
4-257 and 4-258
4-261 through 4-284
4-297 through 4-302
4-349 and 4-350
4-357 through 4-362
4-369 through 4-372
4-377 and 4-378
4-383 and 4-384
4-483 and 4-484
4-504.1/(4-504.2 blank)
4-505 through 4-510
4-629 through 4-632
4-653 through 4-660
4-667 through 4-676
4-683 through 4-702
4-707 through 4-712
4-717 through 4-722
4-725 and 4-726
4-753 and 4-754
4-759 and 4-760
4-771 through 4-774
4-789 through 4-792

Insert Pages

A and B
i and ii
4-7 and 4-8
4-15 and 4-16
4-87 and 4-88
4-257 and 4-258
4-261 through 4-284
4-297 through 4-302
4-349 and 4-350
4-357 through 4-362
4-369 through 4-372
4-377 and 4-378
4-383 and 4-384
4-483 and 4-484
4-504.1/(4-504.2 blank)
4-505 through 4-510
4-629 through 4-632
4-653 through 4-660
4-667 through 4-676
4-683 through 4-702
4-707 through 4-712
4-717 through 4-722
4-725 and 4-726
4-753 and 4-754
4-759 and 4-760
4-771 through 4-774
4-789 through 4-792

TM 5-2420-224-20-2

Remove Pages

A-1 through A-3/(A-4 Blank)
C-7 and C-8
Index-9 through Index-12

Insert Pages

A-1 through A-4
C-7 and C-8
Index-9 through Index-12

By Order of the Secretary of the Army:

PETER J. SCHOOMAKER
General, United States Army
Chief of Staff

Official:

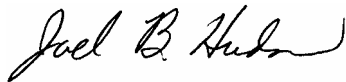

JOEL B. HUDSON
Administrative Assistant to the
Secretary of the Army
0406803

DISTRIBUTION:

To be distributed in accordance with the Initial Distribution Number (IDN) 380973 requirements for TM 5-2420-224-20-2.

CHANGE

HEADQUARTERS
DEPARTMENT OF THE ARMY
Washington, D.C., 7 October 2003

NO. 1

**UNIT MAINTENANCE MANUAL
FOR
TRACTOR, WHEELED, 4 X 4 DED
SMALL EMPLACEMENT EXCAVATOR (SEE)
(NSN 2420-01-160-2754) (EIC:EDL)**

AND

**TRACTOR, WHEELED, 4 X 4 DED
HIGH MOBILITY MATERIAL HANDLER (HMMH)
(NSN 2420-01-205-8636)**

TM 5-2420-224-20-2, dated 28 July 1993, is updated as follows:

1. File this sheet in front of the manual for reference.
2. New or changed material is indicated by a vertical bar adjacent to the material and/or change designators at bottom of affected page.
3. New or changed illustrations are indicated by a vertical bar adjacent to the illustration or miniature pointing hand adjacent to the updated area.
4. Remove old pages and insert new pages as indicated below.

Remove Pages

None
iii through vi
4-5 and 4-6
4-35 through 4-38
4-135 and 4-136
4-149 and 4-150
4-267 through 4-270
4-301 and 4-302
4-303 through 4-306
4-337 and 4-338
4-341 and 4-342
4-503 and 4-504
4-719 through 4-722
B-3 through B-6
B-13 and B-14
C-5 and C-6
D-1 through D-4
E-1 and E-2
Index-1 and Index-2
Index-5 and Index-6
Index-11 through Index-14
Index-17/(Index-18 Blank)
None

Insert Pages

A/(B Blank)
iii through vi
4-5 and 4-6
4-35 and 4-38
4-135 and 4-136
4-149 and 4-150
4-267 through 4-270
4-301 through 4-302.1/(4-302.2 Blank)
4-303 through 4-306
4-337 and 4-338
4-341 and 4-342
4-503 through 4-504.1(4-504.2 Blank)
4-719 through 4-722
B-3 through B-6
B-13 and B-14
C-5 and C-6
D-1 through D-5/(D-6 Blank)
E-1 and E-2
Index-1 and Index-2
Index-5 and Index-6
Index-11 through Index-14
Index-17/(Index-18 Blank)
DA Form 2028

TM 5-2420-224-20-2

By Order of the Secretary of the Army:

PETER J. SCHOOMAKER
General, United States Army
Chief of Staff

Official:



JOEL B. HUDSON
Administrative Assistant to the
Secretary of the Army
0222002

DISTRIBUTION:

To be distributed in accordance with the Initial Distribution Number (IDN) 380973 requirements for TM 5-2420-224-20-2.

LIST OF EFFECTIVE PAGES

Dates of issue for original – changed pages are:

Original 0 28 July 1993
 Change 1 7 October 2003
 Change 2 30 March 2004

TOTAL NUMBER OF PAGES IN THIS VOLUME 924, CONSISTING OF THE FOLLOWING:

Page No.	*Change No.	Page No.	*Change No.	Page No.	*Change No.
Front Cover	0	4-281	0	4-661 – 4-666	0
a – m	0	4-282	2	4-667 – 4-670	2
A – B	2	4-283	0	4-671	0
Instruction Sheet for Change 2	2	4-284	2	4-672 – 4-676	2
Instruction Sheet for Change 1	1	4-285 – 4-297	0	4-677 – 4-683	0
i	2	4-298 – 4-301	2	4-684 – 4-702	2
ii	0	4-302	1	4-703 – 4-707	0
iii – iv	1	4-302.1 Added	1	4-708 – 4-709	2
v	0	4-302.2 Blank Added	1	4-710	0
vi	1	4-303 – 4-305	1	4-711 – 4-712	2
vii – xv	0	4-306 – 4-336	0	4-713 – 4-717	0
xvi Blank	0	4-337 – 4-338	1	4-718 – 4-722	2
4-1 – 4-4	0	4-339 – 4-340	0	4-723 – 4-725	0
4-5 – 4-6	1	4-341 – 4-342	1	4-726	2
4-7 – 4-8	2	4-343 – 4-348	0	4-727 – 4-753	0
4-9 – 4-14	0	4-349 – 4-350	2	4-754	2
4-15 – 4-16	2	4-351 – 4-356	0	4-755 – 4-758	0
4-17 – 4-34	0	4-357	2	4-759	2
4-35 – 4-37	1	4-358	0	4-760 – 4-771	0
4-38 – 4-86	0	4-359 – 4-361	2	4-772 – 4-773	2
4-87 – 4-88	2	4-362 – 4-368	0	4-774 – 4-789	0
4-89 – 4-134	0	4-369	2	4-790	2
4-135	1	4-370	0	4-791	0
4-136 – 4-149	0	4-371	2	4-792	2
4-150	1	4-372 – 4-377	0	4-793 – 4-806	0
4-151 – 4-256	0	4-378	2	A-1	0
4-257 – 4-258	2	4-379 – 4-382	0	A-2 – A-4	2
4-259 – 4-261	0	4-383	2	B-1 – B-3	0
4-262	2	4-384 – 4-482	0	B-4 – B-5	1
4-263	0	4-483	2	B-6 – B-12	0
4-264 – 4-265	2	4-484 – 4-502	0	B-13	1
4-266	0	4-503 – 4-504	1	B-14 – B-28	0
4-267 – 4-268	2	4-504.1	2	C-1 – C-4	0
4-269	1	4-504.2 Blank Added	1	C-5	1
4-270 – 4-271	2	4-505	2	C-6 – C-7	0
4-272	0	4-506	0	C-8	2
4-273 – 4-278	2	4-507 – 4-510	2	D-1 – D-4	1
4-279	0	4-511 – 4-629	0	D-5 Added	1
4-280	2	4-630 – 4-631	2	D-6 Blank Added	1
		4-632 – 4-653	0	E-1	1
		4-654 – 4-660	2		

*Zero in this column indicates an original page

TM 5-2420-224-20-2

Page No.	*Change No.
E-2 – E-4	0
Index-1	1
Index-2 – Index-5	0
Index-6	1
Index-7 – Index-9	0
Index-10 – Index-11	2
Index-12	0
Index-13	1
Index-14 – Index-16	0
Index-17	1
Index-18 Blank	0
DA Form 2028 Sample (front/back)	1
DA Form 2028 (front/back)	1
Metric Chart	0
Back Cover	1

*Zero in this column indicates an original page

**UNIT MAINTENANCE MANUAL
FOR
TRACTOR, WHEELED, 4 X 4 DED
SMALL EMPLACEMENT EXCAVATOR (SEE)
(NSN 2420-01-160-2754) (EIC:EDL)**

AND

**TRACTOR, WHEELED, 4 X 4 DED
HIGH MOBILITY MATERIAL HANDLER (HMMH)
(NSN 2420-01-205-8636)**

VOLUME 2 OF 2

REPORTING ERRORS AND RECOMMENDING IMPROVEMENTS

You can help improve this publication. If you find any mistakes or if you know of a way to improve the procedures, please let us know. Submit your DA Form 2028 (Recommended Changes to Publications and Blank Forms), through the Internet, on the Army Electronic Product Support (AEPS) website. The Internet address is <http://aeeps.ria.army.mil>. If you need a password, scroll down and click on "ACCESS REQUEST FORM". The DA Form 2028 is located in the ONLINE FORMS PROCESSING section of the AEPS. Fill out the form and click on SUBMIT. Using this form on the AEPS will enable us to respond quicker to your comments and better manage the DA Form 2028 program. You may also mail, fax or email your letter or DA Form 2028 direct to: AMSTA-LC-CI / TECH PUBS, TACOM-RI, 1 Rock Island Arsenal, Rock Island, IL 61299-7630. The email address is TACOM-TECH-PUBS@ria.army.mil. The fax number is DSN 793-0726 or Commercial (309) 782-0726.

TABLE OF CONTENTS

	LIST OF TASKS	iii
	HOW TO USE THIS MANUAL	xi
CHAPTER 4	VEHICLE MAINTENANACE INSTRUCTIONS	4-1
Section I	Power Package Maintenance.....	4-2
Section II	Clutch Maintenance.....	4-12
Section III	Fuel System Maintenance.....	4-24
Section IV	Exhaust System Maintenance.....	4-79
Section V	Cooling System Maintenance.....	4-86
Section VI	Electrical System Maintenance	4-109
Section VII	Transmission Maintenance	4-240
Section VIII	Front and Rear Axles Maintenance.....	4-245
Section IX	Brake Maintenance	4-249

This manual along with TM 5-2420-224-20-1 and TM 5-2420-224-34 supersedes
TM 5-2420-224-24 dated December 1989
Approved for public release; distribution unlimited

TABLE OF CONTENTS (CONT)

	Page
Section X	Wheel Maintenance 4-335
Section XI	Steering Maintenance 4-338
Section XII	Frame and Towing Attachments Maintenance 4-362
Section XIII	Springs and Shock Absorbers Maintenance 4-367
Section XIV	Body, Cab, and Hood Maintenance 4-384
Section XV	Body and Chassis Accessory Items Maintenance 4-474
Section XVI	Hydraulic System Maintenance 4-499
Section XVII	Gages (Non-Electrical) Maintenance 4-727
Section XVIII	Machine Tools and Related Equipment Maintenance 4-736
Section XIX	Cranes, Shovels, and Earthmoving Equipment Components Maintenance 4-751
APPENDIX A	<u>REFERENCES.</u> A-1
APPENDIX B	<u>MAINTENANCE ALLOCATION CHART.</u> B-1
APPENDIX C	<u>EXPENDABLE SUPPLIES AND MATERIALS LIST</u> C-1
APPENDIX D	<u>ILLUSTRATED LIST OF MANUFACTURED ITEMS</u> D-1
APPENDIX E	TORQUE LIMITS E-1
	INDEX Index-1

LIST OF TASKS

A list of the maintenance procedures included in this manual is shown below, and on the following pages. If more information is needed, refer to the Table of Contents or the Alphabetical Index.

POWER PACKAGE MAINTENANCE (Section I)

	Page
Valve Cover and Gasket Replacement	4-3
Valve Adjustment	4-5
Oil Filler Cap Replacement.	4-6
Engine Oil Filter Element and Bowl Replacement	4-7
Engine Oil Hose and Fittings Replacement.	4-9
Engine Inlet and Outlet Air Lines Replacement.	4-10

CLUTCH MAINTENANCE (Section II)

Clutch Pedal Replacement and Adjustment	4-13
Clutch Hydraulic Reservoir Replacement	4-15
Clutch Hydraulic Reservoir Lines and Fittings Replacement	4-17
Clutch Slave Cylinder Replacement.	4-19
Clutch Master Cylinder Replacement	4-21

FUEL SYSTEM MAINTENANCE (Section III)

Fuel Injector Lines Replacement	4-25
Fuel Primer Pump Replacement.	4-29
Hand Primer Replacement.	4-31
Air Cleaner Replacement.	4-32
Air Cleaner Filter Elements Servicing/Replacement	4-35
Air Cleaner Ducts Replacement	4-38
Vertical Air Intake Pipe Replacement	4-39
Fuel Tank Draining	4-40
Fuel System Bleeding	4-41
Fuel Tank Replacement	4-42
Fuel Tank Lines and Fittings Replacement	4-44
Fuel Cap, Fittings, and Controls Replacement	4-47
Fuel Filter Element Replacement	4-48
Fuel Filter Assembly Replacement and Repair.	4-50
Fuel Filter Pre-Sediment Bowl and Filter Replacement	4-54
Cold Start Aid Replacement	4-55
Accelerator Pedal and Linkage Replacement	4-58
Accelerator Linkage Replacement.	4-64
Accelerator Linkage Adjustment.	4-68
Hand Throttle Replacement	4-70
Air Cylinder Replacement (SEE).	4-72
Air Cylinder Replacement (HMMH)	4-74
Air Cylinder Adjustment (SEE).	4-76
Air Cylinder Adjustment (HMMH)	4-77

EXHAUST SYSTEM MAINTENANCE (Section IV)

Muffler Replacement	4-80
Muffler Pipes and Clamps Replacement	4-81
Exhaust Manifold Screening Plate Replacement.	4-85

LIST OF TASKS

COOLING SYSTEM MAINTENANCE (Section V)

	Page
Cooling System Service	4-87
Cooling System Test	4-89
Coolant Expansion Tank Filler Cap Pressure Test	4-90
Radiator Replacement	4-92
Coolant Expansion Tank Replacement	4-96
Coolant Expansion Tank Support Replacement	4-97
Coolant Hoses and Clamps Replacement.	4-98
Coolant Thermostat Replacement	4-100
Coolant Water Outlet Replacement	4-101
Water Manifold and Gasket Replacement.	4-102
Water Pump Replacement	4-104
Fan Impeller Replacement	4-105
Fan Belt Replacement	4-106
Fan Belt Adjustment.	4-108

ELECTRICAL SYSTEM MAINTENANCE (Section VI)

Alternator and Alternator Bracket Replacement.	4-112
Starter Replacement	4-117
Starter Solenoid Replacement	4-119
Polarity Breaker and Suppressor Filter Mounting Bracket Replacement	4-120
Polarity Breaker Replacement	4-121
Turn Signal Level Replacement	4-122
Press-to-Test Switch Replacement	4-123
Indicator (Gage) Replacement	4-124
Tachometer Replacement	4-128
Ignition Switch Replacement	4-131
Windshield Wiper/Washer Switch Replacement	4-132
Starter Switch Replacement	4-133
Hazard Warning Switch Replacement.	4-134
Voltmeter Gage Replacement	4-135
Cold Start Switch Replacement	4-136
Master Light Switch Replacement	4-137
Instrument Cluster Panel Light Replacement	4-138
Windshield Heater Control Switch Relay Replacement	4-139
Windshield Wiper/Washer Switch Relay Replacement.	4-140
Warning Delay Relay Replacement	4-141
Hydraulic Suspension Lockout Controls Replacement.	4-142
Auxiliary Light Control Switch Replacement.	4-146
Hydraulic Oil Cooler Thermal Switch Replacement.	4-147
Relay Replacement	4-150
Bucket and Auxiliary Throttle Switches Replacement	4-151
Throttle Control Switch Replacement (SEE)	4-154
Auxiliary Throttle Switch Replacement	4-156
Throttle Control Switch Replacement (HMMH)	4-158
Tool and Work Light Switches Replacement	4-162
Fuse Holder Replacement	4-166
Brake Light Diode Replacement	4-168
Fuse Replacement	4-169
Low Oil Pressure and High Water Temperature Alarm Replacement.	4-170
Main (Master) Disconnect Switch Replacement	4-171
Slave Receptacle Replacement	4-172

LIST OF TASKS (CONT)

ELECTRICAL SYSTEM MAINTENANCE (Section VI)-CONT

	Page
Headlight Replacement	4-173
Auxiliary Headlight Replacement.,	4-175
Auxiliary Headlight Adjustment	4-179
Front Blackout Light Replacement and Repair	4-181
Front Composite Light Replacement and Repair	4-183
Work Light Replacement and Repair	4-186
Crane Mast Floodlight Replacement and Repair	4-188
Rear Composite Stoplight/Taillight Replacement and Repair	4-190
Dome Light Replacement	4-195
Turn Signal Flasher Relay Replacement	4-196
Engine Start Switch Replacement..	4-199
Brake Light Switch Replacement	4-200
Starter Lockout/Intermediate Speed Shift Sending Unit Replacement	4-201
Oil Pressure Sender Replacement..	4-202
Water Temperature Sending Unit Replacement	4-203
Fuel Level Gage Replacement	4-204
Air Cleaner Restrictor Indicator Switch Replacement	4-205
Power Take-Off Indicator Switch Replacement	4-206
Differential Lock Indicator Switch Replacement	4-207
Backup Alarm Switch Replacement.	4-208
Intermediate Speed Shift and Indicator Switch Replacement	4-209
Parking Brake Switch Replacement.	4-210
STE/ICE-R Resistor Replacement..	4-211
STE/ICE-R Fuel Pressure Switch Replacement	4-212
STE/ICE-R Shunt Replacement	4-213
Backup Alarm Replacement	4-214
Horn, Low Beam/High Beam Switch Replacement	4-215
Horn Replacement	4-218
Battery Replacement	4-219
Battery Cables Replacement	4-221
Battery Box Replacement	4-226
Battery Box Repair	4-228
Trailer Connection Replacement..	4-230
Front Disc Brake Pad Indicator Wiring Harness Replacement	4-231
Suppressor Filters Replacement..	4-235
Engine Temperature Switch Replacement	4-238

TRANSMISSION MAINTENANCE (Section VII)

All Wheel Drive Selector Valve Replacement	4-240
All Wheel Drive Pressure Regulator Replacement	4-242
All Wheel Drive Control Cylinder Replacement And Adjustment	4-243

FRONT AND REAR AXLES MAINTENANCE (Section VIII)

Axle Vent Hoses Replacement	4-245
Front Axle Final Drive Outer Seal Replacement	4-247
Rear Axle Final Drive Outer Seal Replacement	4-248

LIST OF TASKS (CONT)

BRAKE MAINTENANCE (Section IX)

	Page
Parking Brake Controls Replacement	4-251
Parking Brake Adjustment	4-254
Brake Fluid Reservoir Replacement	4-257
Front Trailer Coupling Replacement	4-259
Protection/Relay Valve Replacement	4-261
Brake System Bleeding	4-262
Brake Disc and Hub Replacement	4-265
Rear Disc Brake Pad Replacement	4-268
Front Disc Brake Pad Replacement	4-271
Brake Caliper Replacement	4-274
Brake Master Cylinder Replacement	4-276
Rear Brake Calipers Hydraulic Lines and Fittings Replacement	4-278
Brake Master Cylinder Hydraulic Lines and Fittings Replacement	4-280
Brake Pressure Regulator (ALB Valve) Lines and Fittings Replacement	4-282
Front Brake Calipers Hydraulic Lines and Fittings Replacement	4-284
Brake Pedal Replacement	4-286
Brake Pedal Adjustment	4-287
Air Pressure Tanks Replacement	4-288
Air Brake Booster Replacement	4-295
Antifreeze Reservoir Replacement	4-298
Antifreeze Device Replacement	4-300
Large Air Pressure Tank Overflow Valve and Fittings Replacement	4-302
Small Air Pressure Tank Overflow Valve and Fittings Replacement	4-303
Accessory Air Supply Overflow Valve and Fittings Replacement	4-304
Fluid Regulating Valve Replacement	4-306
Trailer Service Air Supply Lines and Fittings Replacement	4-307
Trailer Emergency Air Supply Lines and Fittings Replacement	4-310
Trailer Air Supply Valve Lines and Fittings Replacement	4-313
Air Pressure and Accessory Air Supply Lines and Fittings Replacement	4-315
Brake Booster and Air Pressure Lines and Fittings Replacement	4-318
Protection/Relay Valve Lines and Fittings Replacement	4-320
Tandem Valve Replacement	4-322
Air System Supply Lines and Fittings Replacement	4-324
Trailer Hand Brake Valve Replacement	4-326
Trailer Air Supply Valve Replacement	4-331
Tractor Protection Valve Replacement	4-332
Trailer Hand Brake Air Supply Lines and Fittings Replacement	4-333

WHEEL MAINTENANCE (Section X)

Wheel Assembly Replacement	4-335
Tire Replacement	4-337

STEERING MAINTENANCE (Section XI)

Tie Rod Replacement and Repair	4-338
■ Tie Rod and Steering Stop Adjustment	4-341
Steering Wheel Replacement	4-343
Steering Wheel Bracket and Seal Replacement	4-344
Drag Link Replacement and Adjustment	4-346

LIST OF TASKS (CONT)

STEERING MAINTENANCE (Section XI)-CONT

	Page
Steering Arm Replacement	4-349
Steering Upper Shaft Bearing Replacement	4-351
Power Steering Gear Adjustment.	4-354
Power Steering Pump Belt Replacement and Adjustment	4-356
Power Steering Lines and Fittings Replacement	4-357
Power Steering Filter Element Replacement	4-359
Power Steering Tank (Reservoir) Replacement	4-360

FRAME AND TOWING ATTACHMENTS MAINTENANCE (Section XII)

Backhoe Subframe Deck Replacement	4-362
Decontamination Mounting Bracket Replacement	4-363
Chassis Tool Box/Deck Plate Replacement	4-364
Pintle Assembly Replacement	4-365

SPRINGS AND SHOCK ABSORBERS MAINTENANCE (Section XIII)

Front Rubber Bumpers Replacement	4-367
Front Shock Absorbers Replacement (SEE)	4-368
Front Shock Absorbers Replacement (HMMH)	4-369
Rear Shock Absorbers Replacement	4-372
Front Control Arm Replacement..	4-374
Rear Control Arm Replacement..	4-375
Front Axle Torsion Bar Replacement	4-376
Rear Axle Torsion Bar Replacement	4-378

BODY, CAB, AND HOOD MAINTENANCE (Section XIV)

Front Plate Replacement	4-385
Canopy (FOPS) Replacement	4-387
Outside Engine Hood Replacement	4-388
Inside Engine Hood Replacement.	4-389
Spare Tire and Mount Replacement (SEE)	4-390
Spare Tire and Mount Replacement (HMMH)	4-391
Cab Door Replacement	4-392
Cab Door and Window Replacement and Repair	4-393
Backhoe Control Tower Replacement	4-404
Front Fender and Splash Guard Replacement	4-409
Splash Guard Replacement	4-412
Cab Door Seal Replacement	4-413
Cab Drain Plug Replacement	4-414
Cab Shock Absorbers and Mountings Replacement	4-415
Cab Tilt and Lower	4-418
Floor Platform Replacement	4-433
Operator Seat and Framework Replacement	4-437
Operator Seat Framework Repair.	4-442
Backhoe Seat Replacement	4-444
Backhoe Seat Repair	4-445
Passenger Seat and Framework Replacement	4-446
Seat Belt Replacement	4-451
Cab Floor Linings Replacement..	4-454
Sun Visor, Clothes Hook, and Grip Handles Replacement	4-455

LIST OF TASKS (CONT)

BODY, CAB, AND HOOD MAINTENANCE (Section XIV)-CONT

	Page
Roof Liner Replacement	4-458
Hose Reel Assembly Replacement and Repair	4-459
Hose Reel Motor Spring Replacement	4-464
Hydraulic Accessory Box Replacement and Repair (SEE)	4-466
Hydraulic Accessory Box Replacement and Repair (HMMH)	4-468
Hydraulic Tool Hoses Replacement	4-471

BODY AND CHASSIS ACCESSORY ITEMS MAINTENANCE (Section XV)

Interior Rear View Mirror Replacement	4-475
Exterior Rear View Mirror Replacement	4-476
Windshield Wiper/Washer Motor Replacement	4-477
Windshield Wiper/Washer Motor Linkage Replacement	4-479
Windshield Wiper Replacement	4-482
Windshield Washer Reservoir Replacement	4-483
Windshield Washer Pump Replacement	4-484
Defroster and Air Tubes Replacement	4-486
Heater Hoses and Clamps Replacement	4-488
Cab Heater Replacement	4-490
Data Plates Replacement	4-492

HYDRAULIC SYSTEM MAINTENANCE (Section XVI)

Front Hydraulic Pump Replacement	4-502
Rear Hydraulic Pump Replacement	4-504
Front Hydraulic Pump Belt Replacement and Adjustment	4-506
Hydraulic Suspension Lockout Filter Replacement	4-507
Crane Hydraulic Motor Replacement	4-509
Hydraulic Suspension Lockout Pump Replacement	4-511
Hydraulic Suspension Lockout Accumulator Replacement	4-516
Backhoe Swing Control Pedal Replacement	4-518
Backhoe Swing Control Pedal Adjustment	4-522
Backhoe Control Lever Replacement	4-523
Backhoe Control Rod Adjustment	4-531
Front Loader/Forklift Control Valve Controls Replacement and Adjustment	4-532
Crane Controls and Linkages Replacement and Adjustment	4-538
Forklift Crosshead Replacement and Adjustment	4-541
Forklift Replacement	4-546
Forklift Rotator Replacement	4-555
Forklift Carriage Chain Adjustment	4-559
Forklift Mast Chain Adjustment	4-562
Forklift Forks Replacement	4-563
Forklift Travel Lock Replacement	4-566
Forklift Front Outrigger Replacement	4-567
Front Loader Hydraulic Relief Valve Replacement	4-568
Left Loader Boom Cylinder Hydraulic Lines and Fittings Replacement	4-569
Right Loader Boom Cylinder Hydraulic Lines and Fittings Replacement	4-572
Left Loader Bucket Rollback Cylinder Hydraulic Lines and Fittings Replacement	4-574
Right Loader Bucket Rollback Cylinder Hydraulic Lines and Fittings Replacement	4-576
Front Loader Hydraulic Lines and Fittings Replacement	4-578
Front Loader/Forklift Hydraulic Lines and Fittings Replacement	4-580
Front Loader/Forklift Control Valve Hydraulic Lines and Fittings Replacement	4-582

LIST OF TASKS (CONT)

HYDRAULIC SYSTEM MAINTENANCE (Section XVI)-CONT

	Page
Front Hydraulic Pump Lines and Fittings Replacement	4-584
Hand Tool Hydraulic Lines and Fittings Replacement	4-586
Front Hydraulic System Return Lines and Fittings Replacement	4-588
Rear Hydraulic Pump Lines and Fittings Replacement	4-590
Rear Hydraulic System Return Lines and Fittings Replacement	4-592
Backhoe/Crane Tilt Cylinder Hydraulic Lines and Fittings Replacement	4-594
Backhoe/Crane Latch Cylinder Hydraulic Lines and Fittings Replacement	4-596
Backhoe/Crane Hydraulic Lines and Fittings Replacement	4-598
Right Backhoe Stabilizer Cylinder Hydraulic Lines and Fittings Replacement	4-600
Left Backhoe Stabilizer Cylinder Hydraulic Lines and Fittings Replacement	4-602
Backhoe Stabilizer Control Valve Hydraulic Lines and Fittings Replacement	4-604
Backhoe Swing Cylinder Hydraulic Lines and Fittings Replacement	4-606
Backhoe Control Valve, Swing Section Hydraulic Lines and Fittings Replacement	4-608
Backhoe Boom Cylinder Hydraulic Lines and Fittings Replacement	4-610
Backhoe Control Valve, Boom Section Hydraulic Lines and Fittings Replacement	4-612
Backhoe Dipper Cylinder Hydraulic Lines and Fittings Replacement	4-614
Backhoe Bucket Cylinder Hydraulic Lines and Fittings Replacement	4-616
Backhoe Control Valve, Bucket Section Hydraulic Lines and Fittings Replacement	4-618
Forklift Tilt Cylinder Hydraulic Lines and Fittings Replacement	4-620
Forklift Hydraulic Lines and Fittings Replacement	4-622
Forklift Rotator Cylinder Hydraulic Lines and Fittings Replacement	4-624
Forklift Pulley Hydraulic Lines and Fittings Replacement	4-626
Forklift Lift Cylinder Hydraulic Lines and Fittings Replacement	4-628
Forklift Lift Cylinder Bleeding	4-630
Crane External End Extension Cylinder Hydraulic Lines and Fittings Replacement	4-632
Crane Turntable Motor Hydraulic Lines and Fittings Replacement	4-634
Crane Inner Boom Lift Cylinder Hydraulic Lines and Fittings Replacement	4-636
Crane Mast Locking Cylinder Hydraulic Lines and Fittings Replacement	4-638
Crane Supply Lines and Fittings Replacement	4-640
Crane Return Lines and Fittings Replacement	4-642
Crane Outer Boom Cylinder Hydraulic Lines and Fittings Replacement	4-644
Crane Horizontal Outrigger Cylinder Hydraulic Lines and Fittings Replacement	4-646
Crane Vertical Outrigger Cylinder Hydraulic Lines and Fittings Replacement	4-648
Hydraulic Suspension Lockout Lines and Fittings Replacement	4-650
Hydraulic Suspension Lockout Pump and Reservoir Lines and Fittings Replacement	4-652
Loader Boom Cylinder Replacement	4-654
Loader Bucket Rollback Cylinder Replacement	4-656
Backhoe Boom Cylinder Replacement	4-658
Backhoe Swing Cylinder Replacement	4-660
Backhoe Bucket Cylinder Replacement	4-668
Backhoe Dipper Cylinder Replacement	4-670
Backhoe Stabilizer Cylinder Replacement	4-673
Backhoe/Crane Tilt Cylinder Replacement	4-675
Backhoe/Crane Latch Cylinder Mounting Replacement	4-677
Backhoe Travel Lock Replacement and Repair	4-678
Backhoe Travel Lock Replacement and Repair	4-681
Backhoe/Crane Latch Cylinder Replacement	4-684
Forklift Tilt Cylinder Replacement.	4-686
Forklift Rotator Cylinder Replacement	4-688
Crane External End Extension Cylinder Replacement	4-690
Crane inner Boom Lift Cylinder Replacement	4-692
Crane Mast Locking Cylinder Replacement	4-694

LIST OF TASKS (CONT)

HYDRAULIC SYSTEM MAINTENANCE (Section XVI)-CONT

	Page
Crane Outer Boom Cylinder Replacement	4-696
Crane Horizontal Outrigger Cylinder Replacement	4-698
Crane Vertical Outrigger Cylinder Replacement	4-700
Front Hydraulic Tank Replacement and Repair	4-702
Front Hydraulic Tank Filter Replacement	4-709
Rear Hydraulic Tank Replacement and Repair	4-712
Hydraulic Tank Sight Indicator Replacement	4-719
Rear Hydraulic Tank Filter Replacement	4-720
Hydraulic Oil Cooler Replacement	4-722

GAGES (NON-ELECTRICAL) MAINTENANCE (Section XVII)

Speedometer Replacement	4-727
Speedometer Drive Shaft Replacement	4-730
inclinometer Replacement and Adjustment	4-731
Counter Engine Revolution (Hourmeter) Replacement	4-733
STE/ICE-R Tachometer Drive and Cable Replacement	4-734

MACHINE TOOLS AND RELATED EQUIPMENT MAINTENANCE (Section XVIII)

Hammer Drill Hoses Replacement	4-736
Impact Wrench Hoses Replacement	4-738
Pavement Breaker Hoses Replacement	4-740
Chain Saw Hoses Replacement.. . . .	4-742
Chain Saw Chain and Bar Replacement	4-744
Chain Saw Trigger, Guard, and Handle Bar Replacement	4-746

CRANES, SHOVELS, AND EARTHMOVING EQUIPMENT COMPONENTS MAINTENANCE (Section XIX)

Backhoe Boom Replacement	4-752
Backhoe Assembly Replacement	4-754
Backhoe Dipper Replacement and Repair.	4-760
Backhoe Bucket Replacement	4-762
Backhoe Bucket (Ripper) Bearings Replacement	4-763
Backhoe Bucket Links Replacement	4-764
Backhoe Bucket/Ripper Tooth Replacement.	4-766
Backhoe Boom Latch Release Lever Replacement	4-768
Backhoe Boom Latch Replacement	4-770
Backhoe Swing Tower Replacement	4-772
Backhoe Stabilizer Replacement	4-774
Crane Replacement	4-776
Crane Hook Assembly Replacement	4-783
Crane Rear Outrigger Replacement.	4-784
Crane Travel Lock Replacement and Adjustment	4-786
Crane Rotation Lock Replacement and Adjustment	4-790
Front Loader Replacement	4-794
Front Loader Main Frame Replacement	4-800
Front Loader Bucket Replacement	4-802
Front Loader Bucket Tooth Replacement	4-804
Front Loader Lift Arm Replacement	4-805

HOW TO USE THIS MANUAL

This manual has an edge index that will help you find specific information in a hurry. Simply spread the pages in the right edge of the manual until the printed blocks can be seen. Open the manual where the block on the edge of the page lines up with your selected topic printed in the front cover block.

OVERVIEW

This manual is organized by chapters, sections, and appendices. A summary of the organization of this manual, by major divisions, follows:

Front cover index gives you a quick reference to chapters, sections, and appendices that you will use often.

WARNINGS—All warnings you should observe while working on or around the SEE/HMMH are shown in this part of the manual. These are repeated in the parts of the manual where they apply.

Table of Contents—The contents of the chapters and appendices are listed here.

Chapter 1—This chapter contains general information about the SEE/HMMH. It also shows and describes major components and lists specific data that you will find helpful while performing maintenance tasks.

Chapter 2—This chapter describes services and inspections that must be performed at the unit level, such as services you must perform upon receipt of the vehicle, and preventive maintenance checks and services. Other sections contain painting and restenciling of markings and general repair and cleaning methods.

Chapter 3—This chapter outlines troubleshooting of the SEE/HMMH and their systems. It includes a troubleshooting index, by symptom and system, and procedures on how to use the STE/ICE-R components while troubleshooting.

Chapter 4—This chapter contains step-by-step instructions for doing the maintenance tasks. Each system of the SEE/HMMH has its own section within the chapter, and any special tools, equipment, or supplies you may need for a task are listed.

Appendix A—This appendix lists the technical manuals and other publications you may have to refer to while working on the SEE/HMMH.

Appendix B—This appendix contains the Maintenance Allocation Chart (MAC) for the SEE/HMMH.

Appendix C—This appendix lists the expendable supplies and materials you will need while performing maintenance on the SEE/HMMH.

Appendix D—This appendix lists and describes any manufactured items you will need for performing maintenance on the SEE/HMMH.

Appendix E—This appendix describes the proper method of tightening fasteners.

Index—The index is an alphabetical listing of the contents of this manual.

Back Cover—The inside back cover contains a metric conversion table.

USING THE MANUAL ON THE JOB

Find the task or component that needs repair by using the LIST OF TASKS (page iii) or the index (page Index-1), then turn to the page listed for that task or component.

Read the INITIAL SETUP procedures, and gather the necessary items and personnel. Pay attention to the warnings. The INITIAL SETUP sheet is described on page xiii.

Although tasks are complete in detail, complete only the part of the task required. For example, if your task is to replace both air cleaner elements, you need not perform the remainder of the task to remove and replace the air cleaner canister.

TM 5-2420-224-20-2

1 → **FORKLIFT REPLACEMENT**

2 → This task covers: a. Removal b. Installation

INITIAL SETUP

3 → **Applicable configuration:**
HMMH

9 → **General Safety Instructions:**

4 → **Tools and Special Equipment:**
Shop Equipment, SC 4910-95-CL-A74
Tool Kit, SC 5180-90-CL-N26
Stand (2), P/N 419 580 70 18

WARNING

- HMMH should not be operated with forklift removed, except in a maintenance facility. When maintenance is required and forklift is removed, never operate HMMH at speeds greater than 5 mph. Tractor stability and handling characteristics are greatly affected with forklift removed. This could cause loss of control and injury to personnel or damage to vehicle.
- High pressure hydraulics [oil under 2450 psi (26,893 kPa)] operate this equipment. Never disconnect any hydraulic line or fitting without first dropping

5 → **Materials/Parts:**
Washer, Lock (2)
Caps and Plugs Appendix C, Item 7
Rags Appendix C, Item 32

6 → **Personnel Required: (2)**

7 → **References:**
TM 5-2420-224-10

8 → **Equipment Condition:**

Reference	Condition Description
Page 2-23	Hydraulic Pressure Relieved

1. TITLE—This is the name of the task.
2. TASK COVERS—This lists all the tasks included in the module.
3. APPLICABLE CONFIGURATION—If the task is applicable to only one of the vehicles, SEE or HMMH (as appropriate) will be, listed here.
4. TOOLS AND SPECIAL EQUIPMENT—These are the tools and equipment you will need to do the task.
5. MATERIALS/PARTS—These are the supplies you will need to do the task. If parts or materials are required, they are listed here or referenced to Appendix C.
6. PERSONNEL REQUIRED—Personnel required to perform a task will be identified if the task requires more than one.
7. REFERENCES—These are the other technical publications you will need to do the task.
8. EQUIPMENT CONDITION—This is the condition(s) the vehicle must be in before you start the task. Other tasks that must be done first are listed by page number or by technical manual number if another manual is required.
9. GENERAL SAFETY INSTRUCTIONS—These are the safety precautions that must be observed while you are doing the task.
10. FOLLOW-ON MAINTENANCE—These are the tasks listed at the end of the procedure that must be completed to return the vehicle to an operational condition.

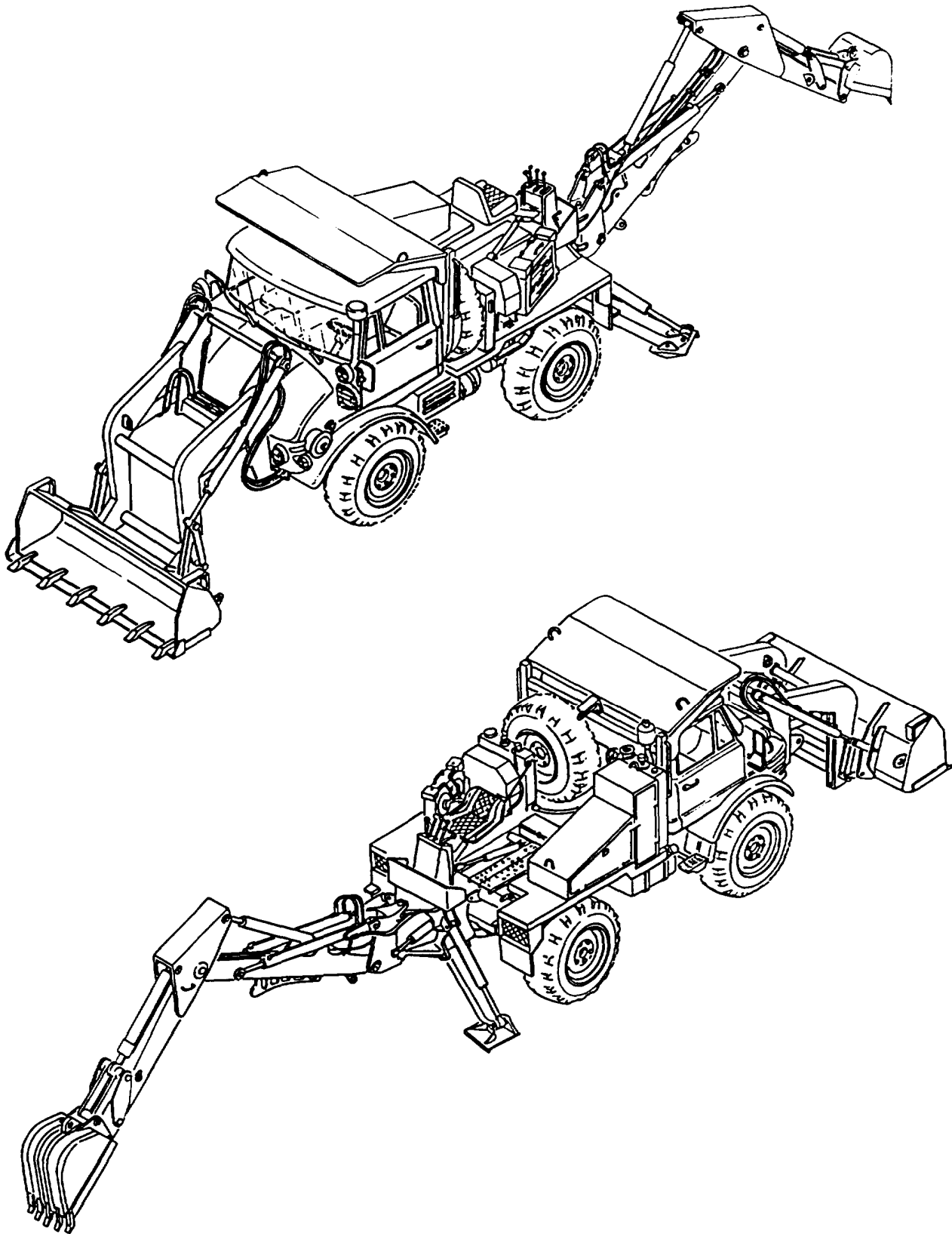

Small Emplacement Excavator (SEE)

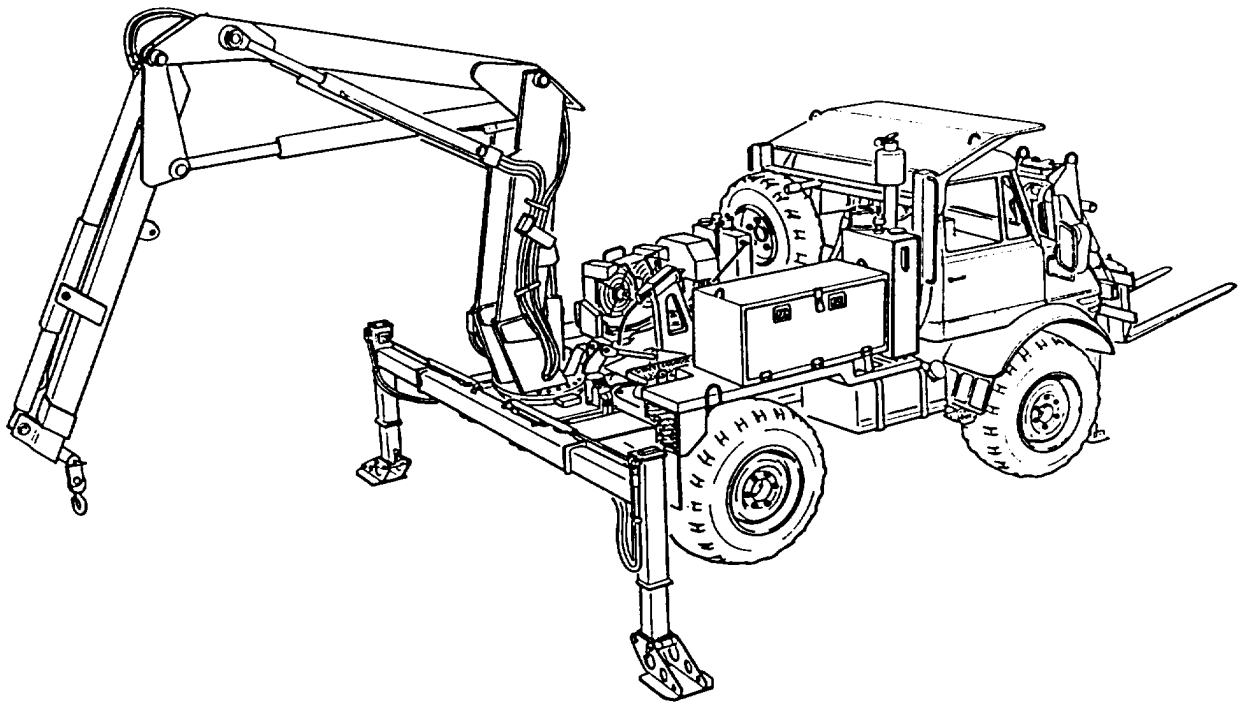
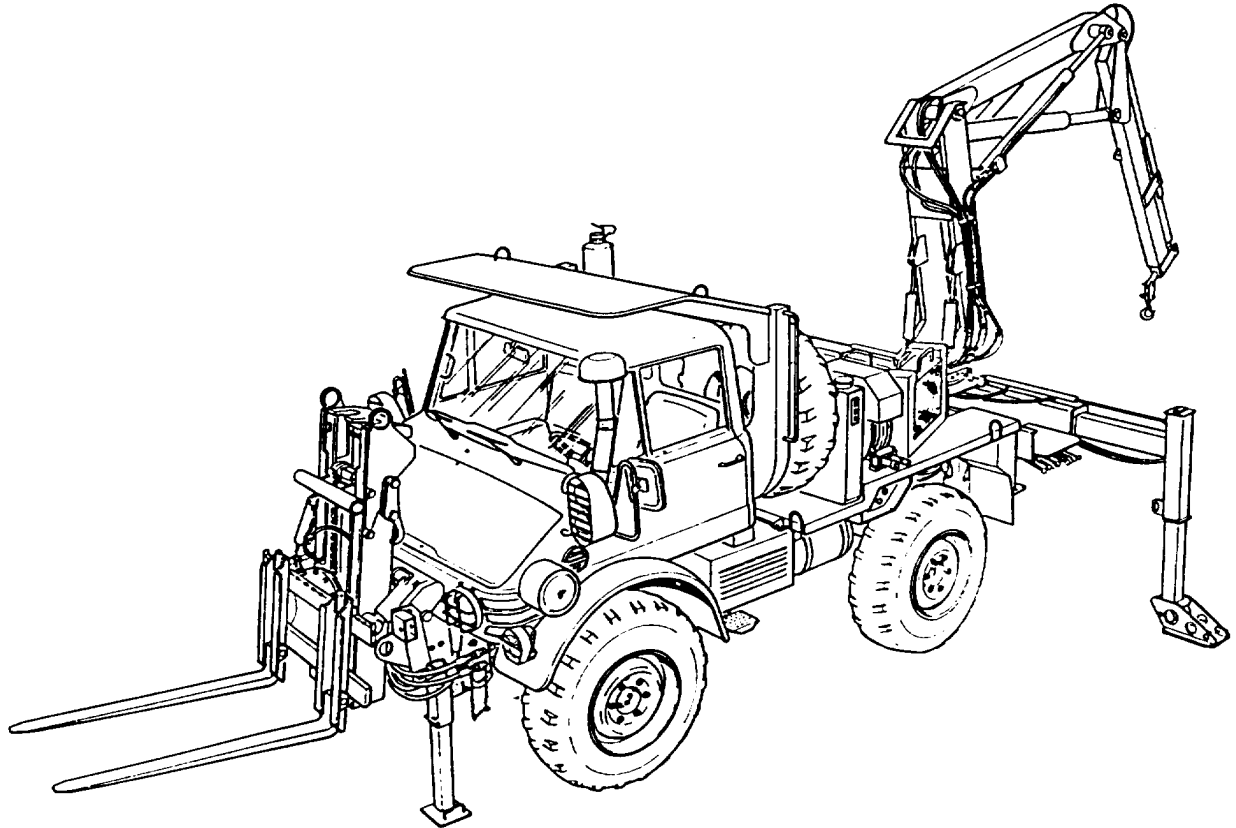

High Mobility Material Handler (HMMH)

CHAPTER 4 VEHICLE MAINTENANCE INSTRUCTIONS

OVERVIEW

This chapter illustrates and describes Procedures for maintenance of the SEE/HMMH. A list of the sections contained in this chapter is shown 'below.

		Page
Section 1.	Power Package Maintenance	4-2
Section II.	Clutch Maintenance	4-12
Section III.	Fuel System Maintenance	4-24
Section IV.	Exhaust System Maintenance	4-79
Section V.	Cooling System Maintenance	4-86
Section VI.	Electrical System Maintenance	4-109
Section VIII.	Transmission Maintenance	4-240
Section VIII.	Front and Rear Axles Maintenance	4-245
Section IX.	Brake Maintenance	4-249
Section X.	Wheel Maintenance	4-335
Section XI.	Steering Maintenance	4-338
Section XII.	Frame and Towing Attachments Maintenance	4-362
Section XIII.	Springs and Shock Absorbers Maintenance	4-367
Section XIV.	Body, Cab, and Hood Maintenance	4-384
Section XV.	Body and Chassis Accessory Items Maintenance	4-474
Section XVI.	Hydraulic System Maintenance	4-499
Section XVII.	Gages (Non-Electrical) Maintenance	4-727
Section XVIII.	Machine Tools and Related Equipment Maintenance	4-736
Section XIX.	Cranes, Shovels, and Earthmoving Equipment Components Maintenance .	4-751

Section I. POWER PACKAGE MAINTENANCE

OVERVIEW

This section illustrates and describes procedures for maintenance of the power package. A list of tasks contained in this section is shown below.

	Page
Valve Cover and Gasket Replacement	4-3
Valve Adjustment	4-5
Oil Separator Replacement	4-6
Engine Oil Fitter Element and Bowl Replacement	4-7
Engine Oil Hose and Fittings Replacement	4-9
Engine Inlet and Outlet Air lines Replacement	4-10

VALVE COVER AND GASKET REPLACEMENT

This task covers: a. Removal b. Installation

INITIAL SETUP

Tools and Special Equipment:

Shop Equipment, SC 4910-95-CL-A74
Tool Kit, SC 5180-90-CL-N26

Materials/Parts:

Washer, Seal Ring (3)

Gasket

Equipment Condition:

Reference

Page 4-389

Condition Description

inside Engine Hood
Removed

REMOVAL

1. REMOVE oil SEPARATOR (1).
2. LOOSEN CLAMP (2) and Disconnect air intake HOSE (3) from valve cover (4).
3. LOOSEN CLAMP (5) and Disconnect air compressor intake LINE (6) from valve cover (4).
4. REMOVE long BOLT (7), two seal ring washers (8), short BOLT (9), and seal ring washer (10) and SWING coolant expansion tank BRACKETS (11) to the side. DISCARD seal ring WASHERS.
5. REMOVE three long bolts (12), three short bolts (13), and valve COVER (4).
6. REMOVE and DISCARD valve cover GASKET (14).
7. IF REPLACING valve COVER (4), REMOVE nut (15) and PIPE (16).

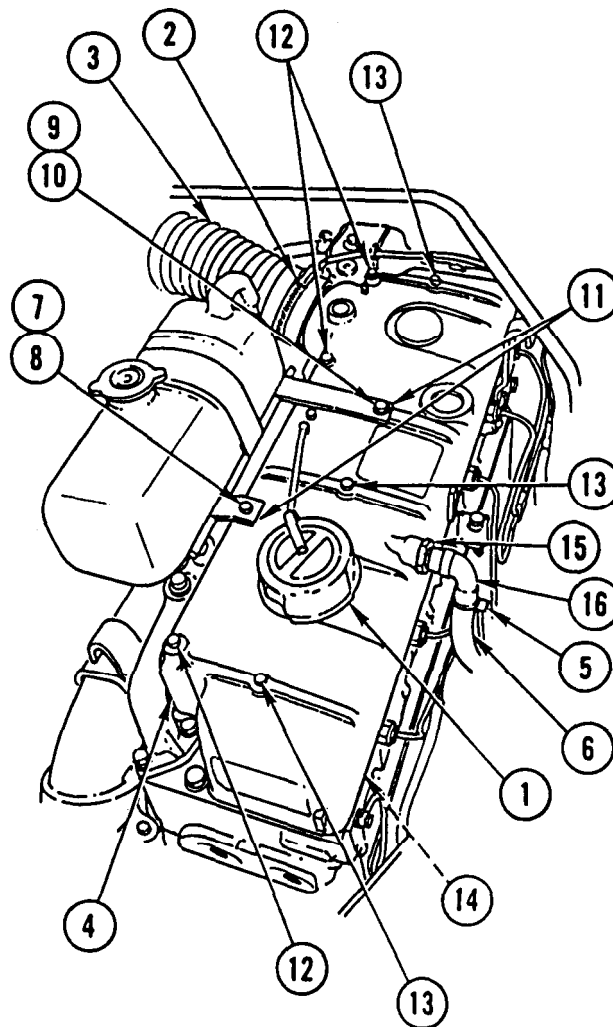

VALVE COVER AND GASKET REPLACEMENT (CONT)

INSTALLATION

CAUTION

Make sure all gasket material has been removed from valve cover and cylinder head to prevent damage to equipment.

1. INSTALL new valve cover GASKET (1) on cylinder head.
2. INSTALL valve COVER (2), three short bolts (3), and three long bolts (4).
3. POSITION expansion tank BRACKETS (5) on valve cover (2) and INSTALL short BOLT (6), new seal ring washer (7), long BOLT (8), and two new seal ring washers (9).
4. TIGHTEN eight valve cover BOLTS (3, 4, 6, and 8) to 19 lb-ft (25 N.m) in following order: 1,2,3,4,5,6,7,8.
5. IF REPLACING valve COVER (2), INSTALL PIPE (10) and nut (11) in new valve cover.
6. CONNECT air compressor intake LINE (12) on valve cover (2). TIGHTEN CLAMP (13).
7. CONNECT air intake HOSE (14) on valve cover (2). TIGHTEN CLAMP (15).
8. INSTALL oil SEPARATOR (16).

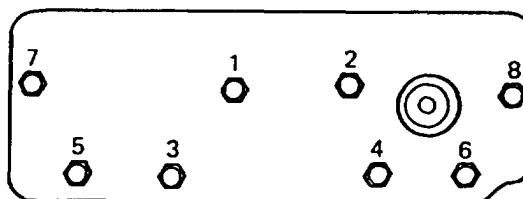
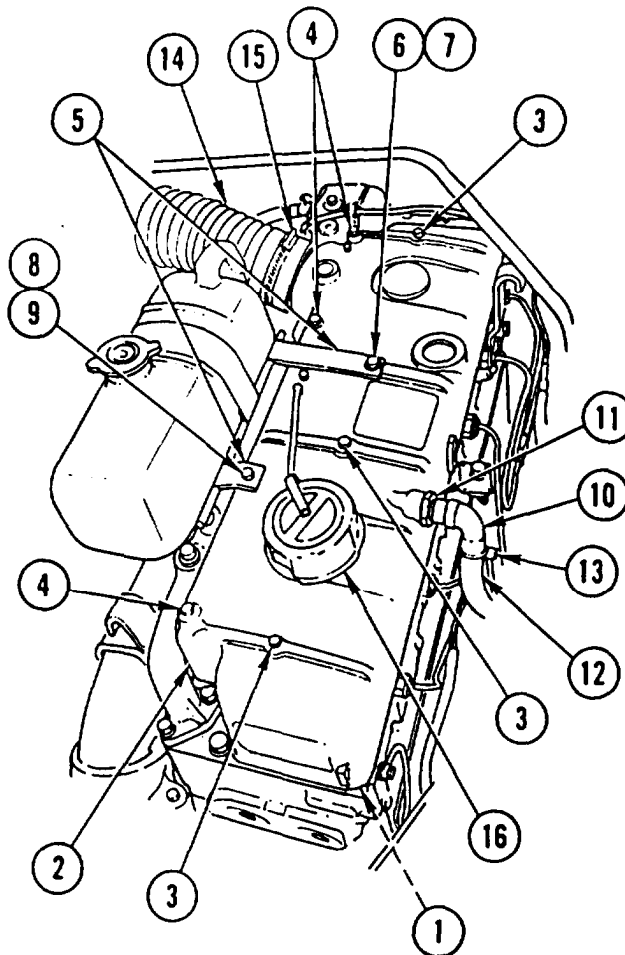

TORQUE SEQUENCE

NOTE

Follow-on Maintenance:
Install inside engine hood (page 4-389).

VALVE ADJUSTMENT

This task covers: Adjustment

INITIAL SETUP

Tools and Special Equipment:

Tool Kit, SC 5180-90-CL-N26

Equipment Condition:

Reference

Page 4-3

Condition Description

Valve Cover Removed

ADJUSTMENT

NOTE

Overlap means both valves are slightly open and rocker arms cannot be moved by hand.

1. Rotate crankshaft to right until rocker arms of No. 6 cylinder overlap. No. 1 cylinder will now be at Top Dead Center (TDC) of compression stroke (both valves will be closed and rocker arms can be moved by hand).

CAUTION

Do not make valve adjustments until engine has cooled to below 122° F (50° C) to prevent damage to equipment.

2. Using feeler gage, check valve clearance. Clearance for intake valves 2, 3, and 7 is 0.008 in. (0.20 mm). Clearance for exhaust valves 1, 5, and 9 is 0.012 in. (0.30 mm).
3. If adjustment is required, loosen nut (1) and insert feeler gage between rocker arm (2) and pad (3). Turn adjusting screw (4) until rocker arm just touches feeler gage. Tighten nut (1) and recheck clearance.

NOTE

Overlap means both valves are slightly open and rocker arms cannot be moved by hand.

4. Rotate crankshaft to right until rocker arms of No. 1 cylinder overlap. No. 6 cylinder will now be at TDC of compression stroke (both valves will be closed and rocker arms can be moved by hand).

5. Repeat steps 2 and 3 for intake valves 6, 10, and 11 and exhaust valves 4, 8, and 12.

NOTE

Follow-on Maintenance:

Install valve cover (page 4-3).

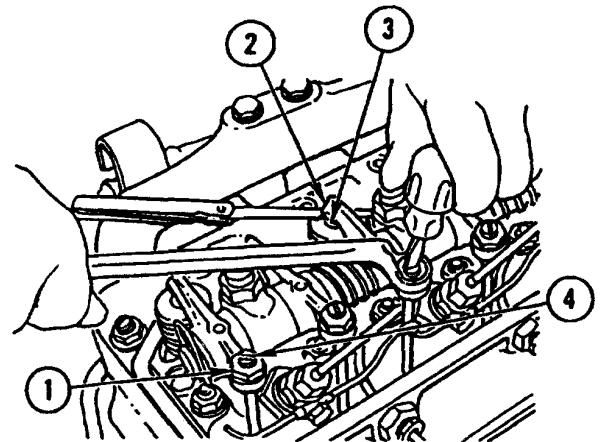

NO. 1 CYLINDER AT COMPRESSION TDC

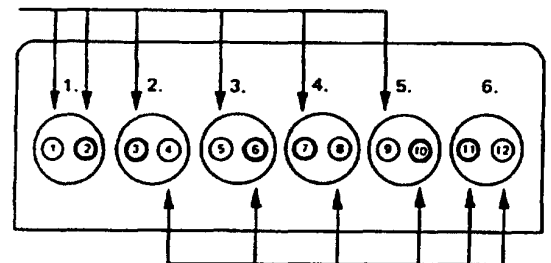

NO. 6 CYLINDER AT COMPRESSION TDC

OIL FILLER CAP REPLACEMENT

This task covers: a. Removal b. Installation

INITIAL SETUP

Tools and Special Equipment:

Tool Kit, SC 5180-90-CL-N26

Materials/Parts:

Gasket

Equipment Condition:

Reference

Page 4-389

Condition Description

Inside Engine Hood
Removed

REMOVAL

1. REMOVE oil FILLER CAP (1) and bracket (2) from valve cover (3).
2. REMOVE and DISCARD GASKET (4).
3. REMOVE pin (5) and BRACKET (2) from oil filler cap (1).

INSTALLATION

1. Install pin (5) and BRACKET (2) on oil filler cap (1).
2. INSTALL oil FILLER CAP (1), new gasket (4), and bracket (2) on valve cover (3).

NOTE

Follow-on Maintenance:

Install inside engine hood (page 4-389).

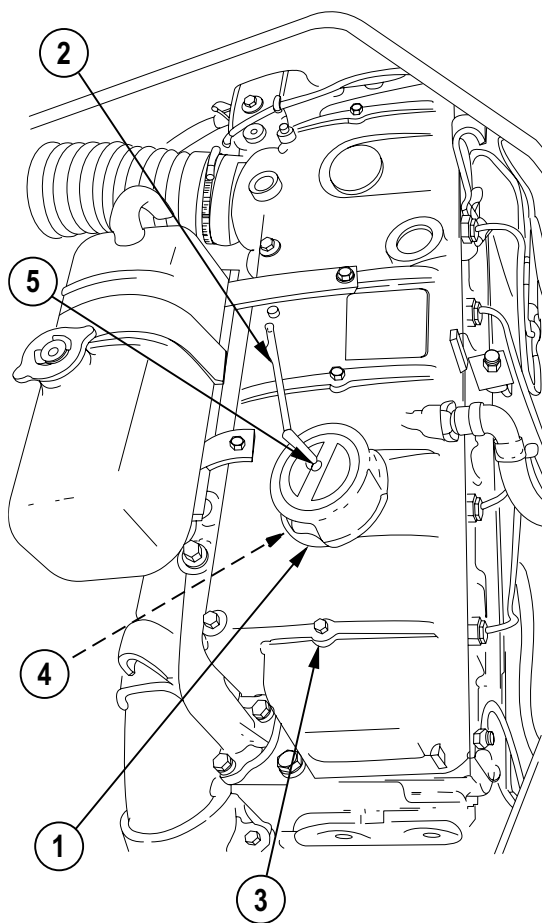

ENGINE OIL FILTER ELEMENT AND BOWL REPLACEMENT

This task covers: a. Removal b. Installation

INITIAL SETUP

Tools and Special Equipment:

Shop Equipment, SC 4910-95-CL-A74
 Tool Kit, SC 5180-90-CL-N26

Materials/Parts:

Seal
 Packing
 Element, Filter
 Oil, Lubricating Appendix C, Item 22
 R a g s Appendix C, Item 32

References:

None

General Safety Instructions:

WARNING

- **BURN HAZARD**
 Allow engine to cool before performing maintenance on the muffler, exhaust pipe, exhaust manifold, or turbocharger. if necessary, use insulated pads and gloves.
- Fuel and oil are slippery and can cause falls. To avoid injury, wipe up spilled fuel or oil with rags.

REMOVAL

1. REMOVE SCREW (1). DRAIN OIL into 1-quart (1-liter) container.
2. LOOSEN BOLT (2) and REMOVE filter BOWL (3) with filter element (4) inside.
3. REMOVE filter ELEMENT (4), spring holder (5), packing (6), and seal (7). DISCARD PACKING, SEAL, and filter ELEMENT.
4. REMOVE oil sample VALVE (8).

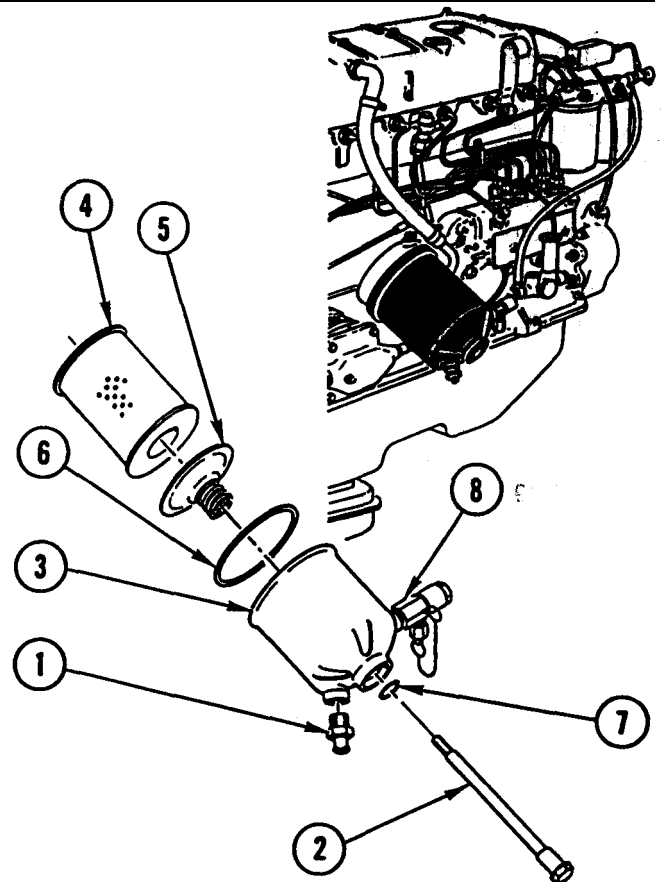

ENGINE OIL FILTER ELEMENT AND BOWL REPLACEMENT (CONT)

INSTALLATION

1. INSTALL new packing (1), new seal (2), spring holder (3), and new filter ELEMENT (4) in filter bowl (5). IF REPLACING filter BOWL, INSTALL PARTS in new bowl.
2. APPLY light COAT of LUBRICATING OIL on top EDGE of filter element gasket (4).
3. INSTALL filter BOWL (5) and TIGHTEN BOLT (6) to 30 ± 7 lb-ft (40 10 N.m).
4. INSTALL SCREW (7) and TIGHTEN to 11 ± 2 lb-ft (15 ± 3 N.m).
5. INSTALL oil sample VALVE (8).
6. FILL filter BOWL (5) with lubricating oil (page 2-14) through fill plug (9).
7. START ENGINE and check for leaks.
8. SHUT OFF ENGINE and check engine oil (page 2-14).

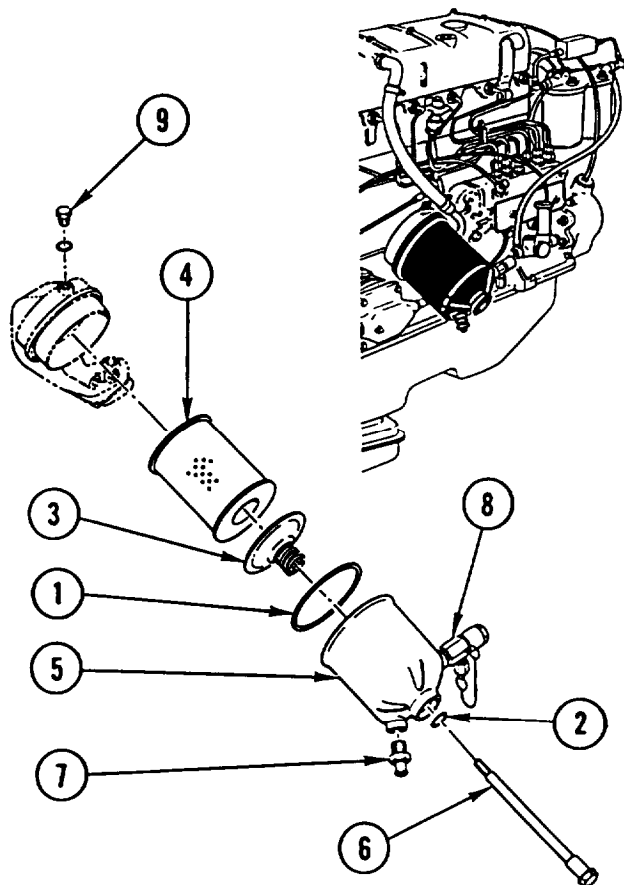

ENGINE OIL HOSE AND FITTINGS REPLACEMENT

This task covers: a. Removal b. Installation

INITIAL SETUP

Tools and Special Equipment:

Tool Kit, SC 5180-90-CL-N26

Materials/Parts:

Packing (4)

General Safety Instructions:

WARNING
BURN HAZARD

Allow engine to cool before performing maintenance on the muffler, exhaust pipe, exhaust manifold, or turbocharger. If necessary, use insulated pads and gloves.

REMOVAL

REMOVE screw (1), bolt (2), HOSE (3), and four packings (4). DISCARD PACKINGS.

INSTALLATION

INSTALL HOSE (3), four new packings (4), screw (1), and bolt (2).

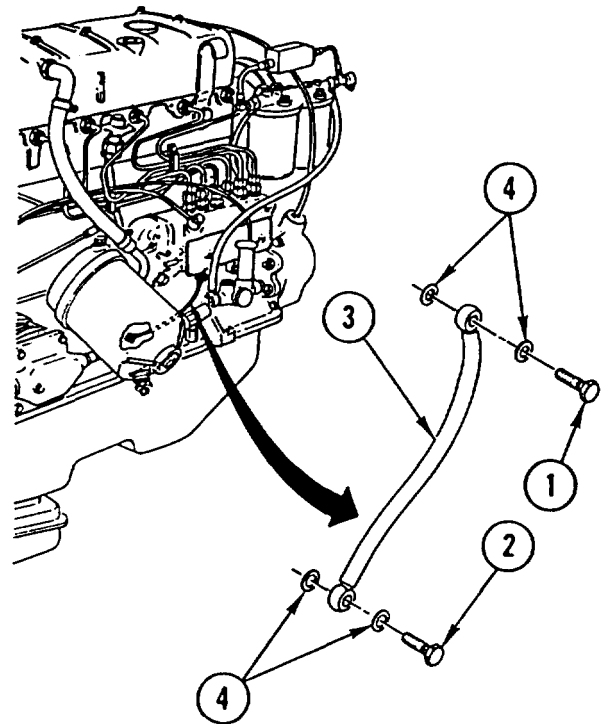

ENGINE INLET AND OUTLET AIR LINES REPLACEMENT

This task covers: a. Removal b Installation

INITIAL SETUP

Tools and Special Equipment:

Tool Kit, SC 5180-90-CL-N26

References:

TM 5-2420-224-10

Equipment Condition:

Reference	Condition	Description
Page 4-389	Inside Engine Hood	Removed
Page 2-23	Air Pressure Relieved	

General Safety Instructions:

WARNING

Do not disconnect any air system lines or fittings unless vehicle engine is shut off and air system pressure is relieved. To do so could result in injury to personnel.

REMOVAL

1. LOOSEN two CLAMPS (1) and REMOVE HOSE (2).
2. LOOSEN NUT (3) and REMOVE PIPE (4) from valve cover (5).
3. LOOSEN NUT (6) and REMOVE PIPE (7) and spacer ring (8) from air compressor (9).
4. LOOSEN NUT (10) and REMOVE PIPE (7) from antifreeze pump (11).
5. REMOVE two screws (12), two nuts (13), and CLAMP (14).
6. REMOVE two screws (15), two nuts (16), clamp (17), and PIPE (7)

INSTALLATION

1. INSTALL PIPE (7), clamp (17), two screws (15), and two nuts (16).
2. INSTALL CLAMP (14), two screws (12), and two nuts (13)
3. CONNECT PIPE (7) to antifreeze pump (11) and TIGHTEN NUT (10)

NOTE

Make sure spacer ring is installed in nut

4. CONNECT PIPE (7) and spacer ring (8) to air compressor (9) and TIGHTEN NUT (6).
5. INSTALL PIPE (4) on valve cover (5) and TIGHTEN NUT (3).
6. INSTALL HOSE (2) and TIGHTEN two CLAMPS (1).

ENGINE INLET AND OUTLET AIR LINES REPLACEMENT (CONT)

NOTE

Follow-on Maintenance:
Start engine and check for air leaks (TM 5-2420-224-10).
Install inside engine hood (page 4-389).

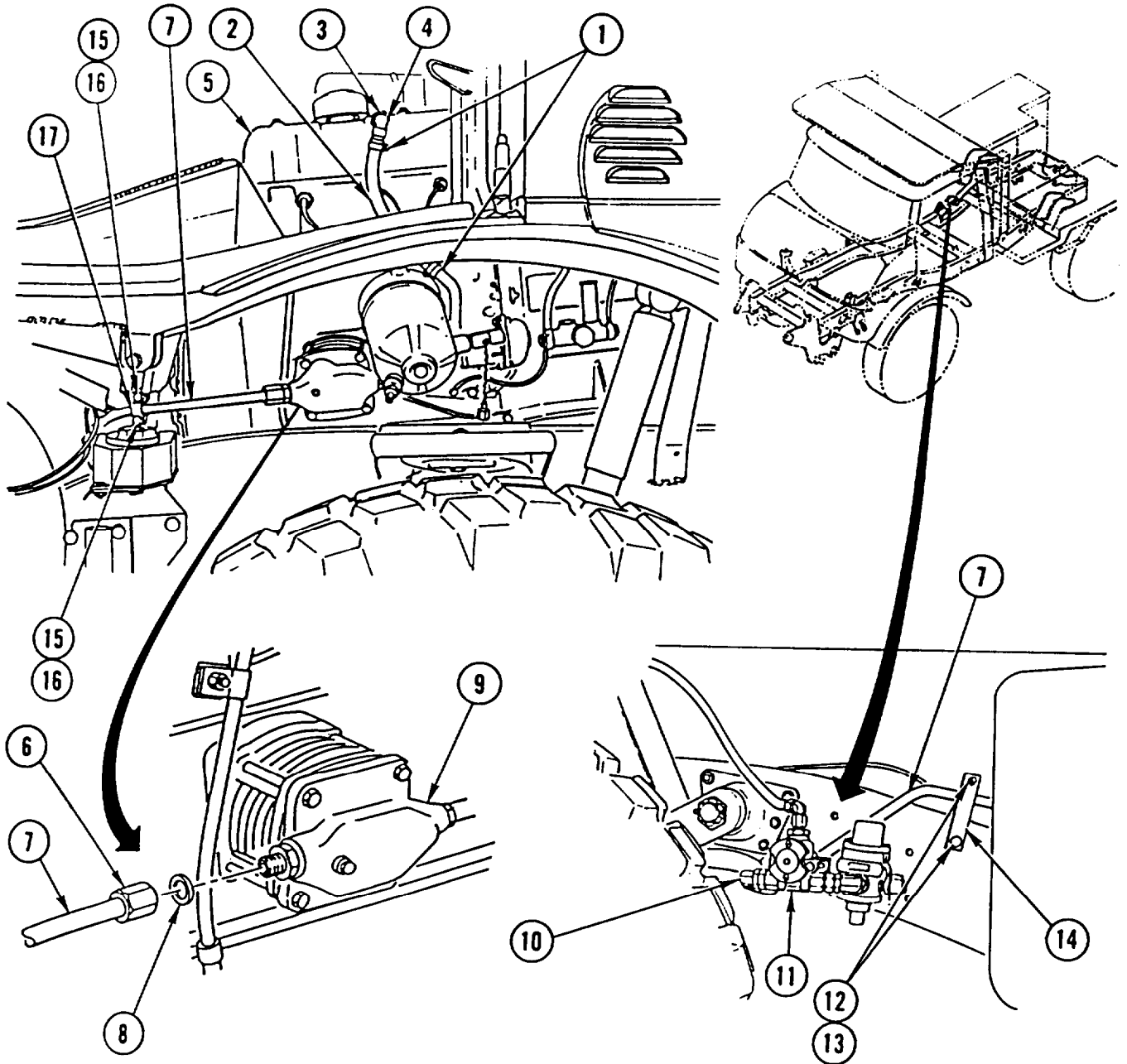

Section II. CLUTCH MAINTENANCE

OVERVIEW

This section illustrates and describes procedures for maintenance of the clutch and related parts. A list of tasks contained in this section is shown below.

	Page
Clutch Pedal Replacement and Adjustment	4-13
Clutch Hydraulic Reservoir Replacement	4-15
Clutch Hydraulic Reservoir Lines and Fittings Replacement	4-17
Clutch Slave Cylinder Replacement	4-19
Clutch Slave Cylinder Adjustment	4-21
Clutch Master Cylinder Replacement	4-22

CLUTCH PEDAL REPLACEMENT AND ADJUSTMENT

This task covers: a. Removal b. Installation c. Adjustment

INITIAL SETUP

Tools and Special Equipment:

Shop Equipment, SC 4910-95-CL-A74
 Tool Kit, SC 5180-90-CL-N26

Materials/Parts:

Washer, Lock (2)

Equipment Condition:

Reference

Page 2-22

Condition Description

Vehicle Blocked

REMOVAL

1. REMOVE nut (1), lock washer (2), two SPACERS (3 and 4), and setscrew (5). DISCARD lock WASHER.
2. REMOVE nut (6), lock washer (7), two SPACERS (8 and 9), and eccentric screw (10). DISCARD lock WASHER.
3. REMOVE spring (11) and clutch PEDAL (12).

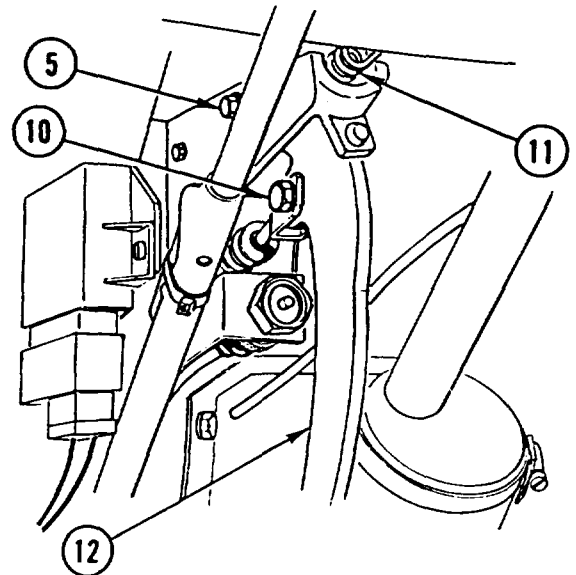

INSTALLATION

1. INSTALL clutch PEDAL (12) and spring (11).
2. INSTALL eccentric screw (10), two SPACERS (8 and 9), new lock washer (7), and nut (6).
3. INSTALL setscrew (5), two SPACERS (3 and 4), new lock washer (2), and nut (1).

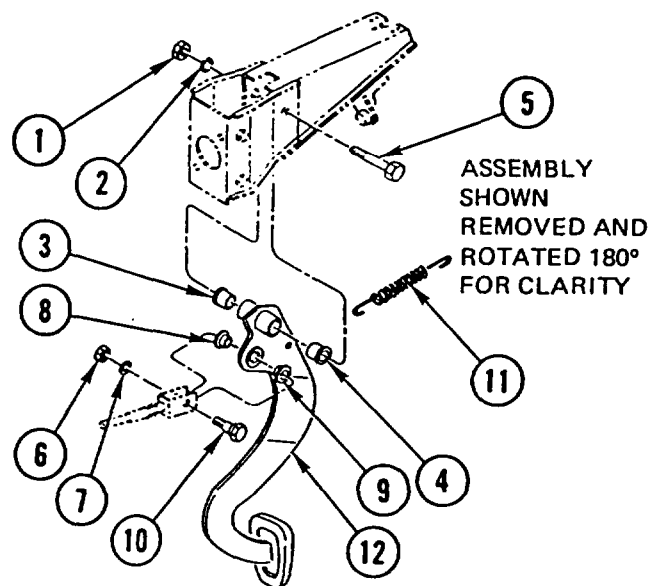

CLUTCH PEDAL REPLACEMENT AND ADJUSTMENT (CONT)

ADJUSTMENT

To adjust clutch pedal lateral movement, rotate eccentric screw (1) to left to increase lateral movement or to right to decrease lateral movement. The maximum allowable lateral movement is 0.06 in. (1.5 mm).

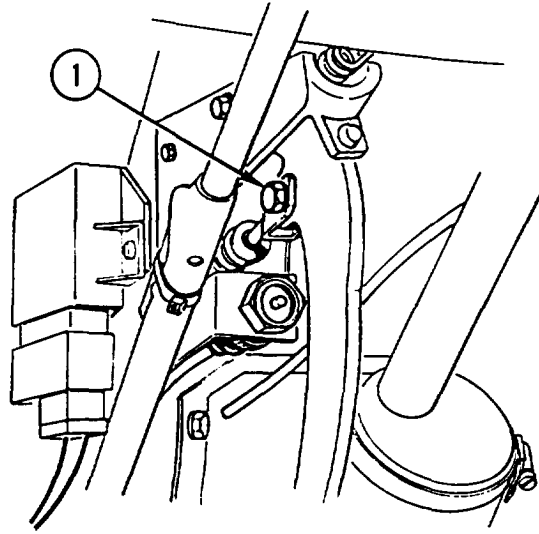

CLUTCH HYDRAULIC RESERVOIR REPLACEMENT (CONT)

4. REMOVE nut (6), washer (7), and clutch RESERVOIR (2).
5. REMOVE and DISCARD PACKING (8) from fitting (9).
6. REMOVE HOSE (3) from clutch reservoir (2).

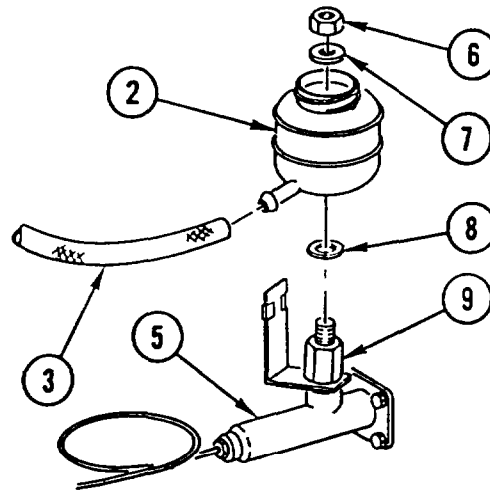

INSTALLATION

1. INSTALL HOSE (1) on clutch reservoir (2).
2. INSTALL new PACKING (3) on fitting (4).
3. INSTALL CLUTCH RESERVOIR (2) on clutch master cylinder (5).

CAUTION

When performing step 4, install washer with grooved side down. Failure to do so will result in breaking clutch reservoir.

4. INSTALL washer (6) and NUT (7) in clutch reservoir (2). TIGHTEN NUT.
5. INSTALL CAP (8) on clutch reservoir (2).
6. CONNECT HOSE (1) to brake master cylinder (9).
7. CONNECT electrical CONNECTORS (10) to clutch reservoir (2).
8. REMOVE CAP (8) from clutch reservoir (2).
9. FILL clutch RESERVOIR (TM 5-2420-224-10).
10. INSTALL CAP (8) on clutch reservoir (2).

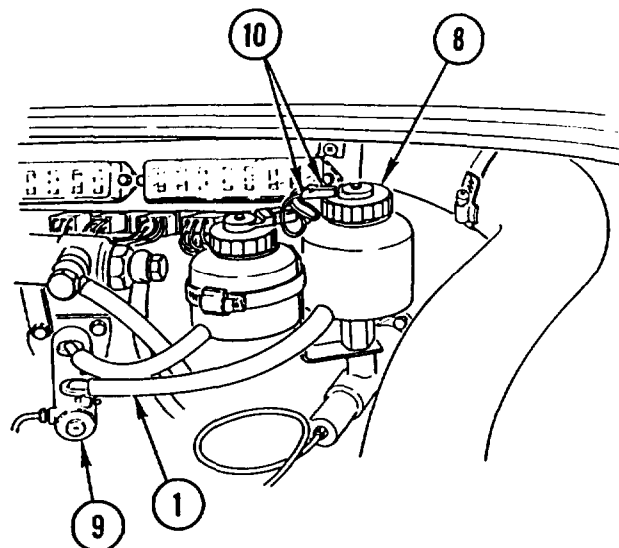
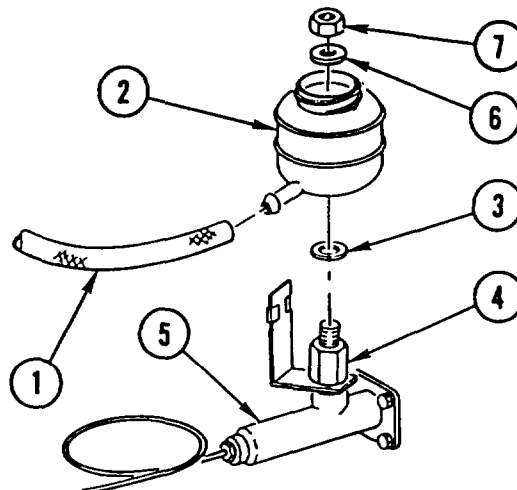

NOTE

Follow-on Maintenance:
Install outside engine hood (page 4-388).

CLUTCH HYDRAULIC RESERVOIR LINES AND FITTINGS REPLACEMENT

This task covers: a. Removal b. Installation

INITIAL SETUP

Tools and Special Equipment:

Shop Equipment, SC 4910-95-CL-A74
Tool Kit, SC 5180-90-CL-N26

Materials/Parts:

Packing (AR)

Packing (AR)

Rags

Appendix C, Item 32

Equipment Condition:

Reference

Page 4-15

Page 4-418

Condition Description

Clutch Hydraulic
Reservoir Removed

Cab Tilted

General Safety Instructions:

WARNING

Fuel and oil are slippery and can cause falls. To avoid injury, wipe up spilled fuel or oil with rags.

REMOVAL

NOTE

Discard packing(s).

REMOVE clutch hydraulic reservoir LINES and FITTINGS using illustration and legend as guide.

INSTALLATION

NOTE

Install new packing(s).

INSTALL clutch hydraulic reservoir LINES and FITTINGS using illustration and legend as a guide.

NOTE

Follow-on Maintenance:

Install clutch hydraulic reservoir (page 4-15).

Lower cab (page 4-418).

CLUTCH HYDRAULIC RESERVOIR LINES AND FITTINGS REPLACEMENT (CONT)

LEGEND

- 1 Fitting
- 2 Packing (2)
- 3 Bracket
- 4 Retaining clip (2)
- 5 Nut (4)
- 6 Screw (4)
- 7 Clamp (4)
- 8 Line (2)
- 9 Hose assembly (2)
- 10 Nut
- 11 Washer
- 12 Packing

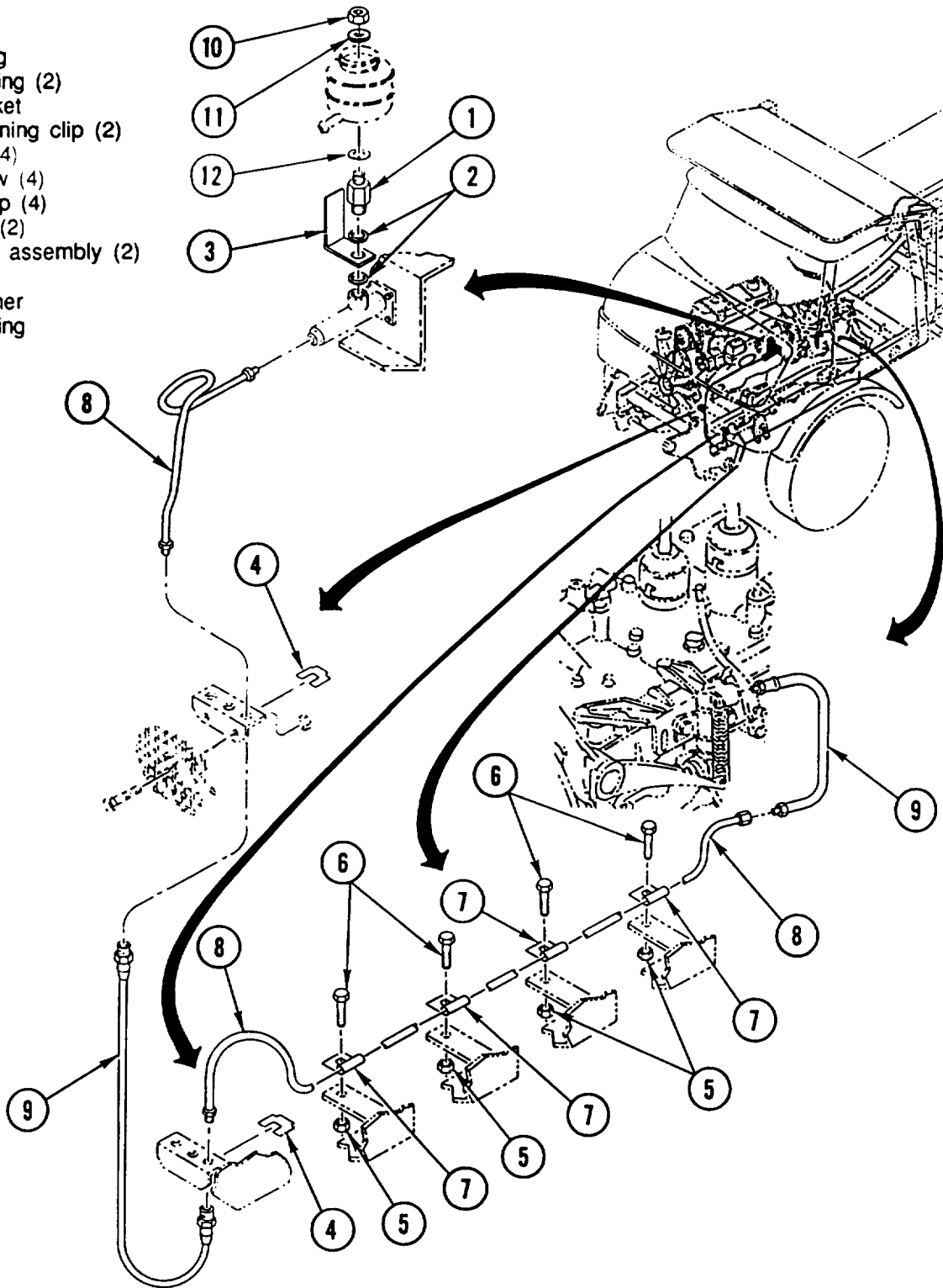

CLUTCH SLAVE CYLINDER REPLACEMENT

This task covers: a. Removal b. Installation

INITIAL SETUP

Tools and Special Equipment:

Shop Equipment, SC 4910-95-CL-A74
 Tool Kit, SC 5180-90-CL-N26

Materials/Parts:

Washer, Spring
 Tension (2)

Rags

Appendix C, Item 32

Equipment Condition:

Reference

Page 4-418

Condition Description

Cab Tilted

WARNING

Fuel and oil are slippery and can cause falls. To avoid injury, wipe up spilled fuel or oil with rags.

REMOVAL

1. DISCONNECT SPRING (1) from clutch lever (2) and clutch slave cylinder (3).

NOTE

Have container available to catch any fluid that may leak out of line or cylinder.

2. REMOVE hydraulic HOSE (4).

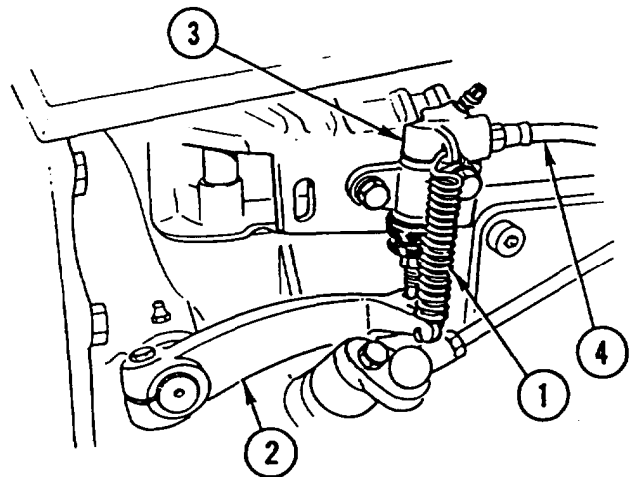

3. REMOVE two bolts (5), two spring tension washers (6), clutch slave CYLINDER (3), shim (7), and threaded spacer plate (8). DISCARD spring tension WASHERS.

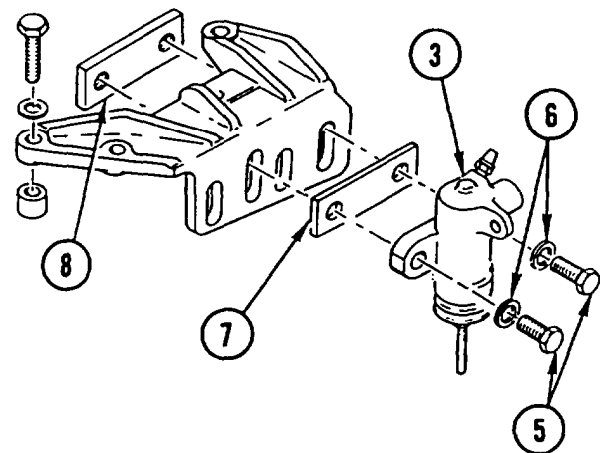

CLUTCH SLAVE CYLINDER REPLACEMENT (CONT)

INSTALLATION

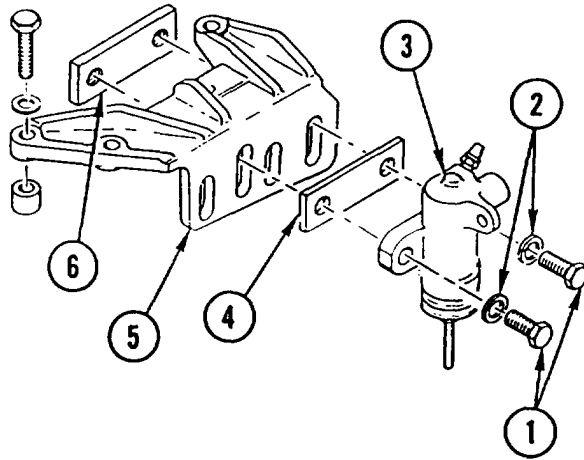

1. INSTALL two BOLTS (1) and two new spring tension washers (2) through clutch slave cylinder (3) mount holes. INSTALL SHIM (4) to back side of clutch slave cylinder (3).
2. INSTALL clutch slave CYLINDER (3) on bracket (5) and INSTALL two BOLTS (1) on threaded spacer plate (6). TIGHTEN BOLTS.

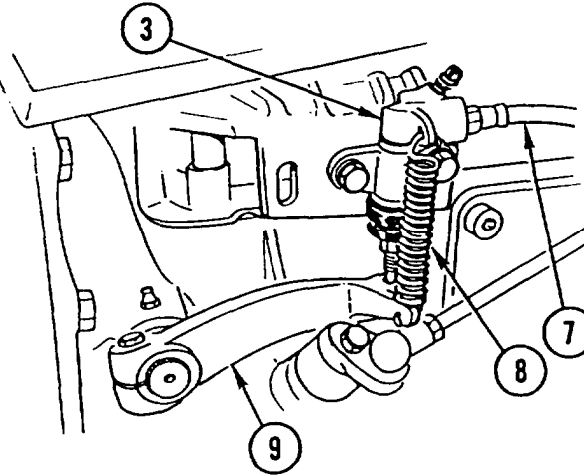

3. INSTALL hydraulic HOSE (7).
4. CONNECT SPRING (8) to clutch lever (9) and clutch slave cylinder (3).

NOTE

Follow-on Maintenance:
 Bleed brake system (page 4-262).
 Adjust clutch slave cylinder (page 4-21).
 Lower cab (page 4-418).

CLUTCH SLAVE CYLINDER ADJUSTMENT

This task covers: Adjustment

INITIAL SETUP

Tools and Special Equipment:

Tool Kit, SC 5180-90-CL-N26

Equipment Condition:

Reference

Page 4-418

Condition Description

Cab Tilted

ADJUSTMENT

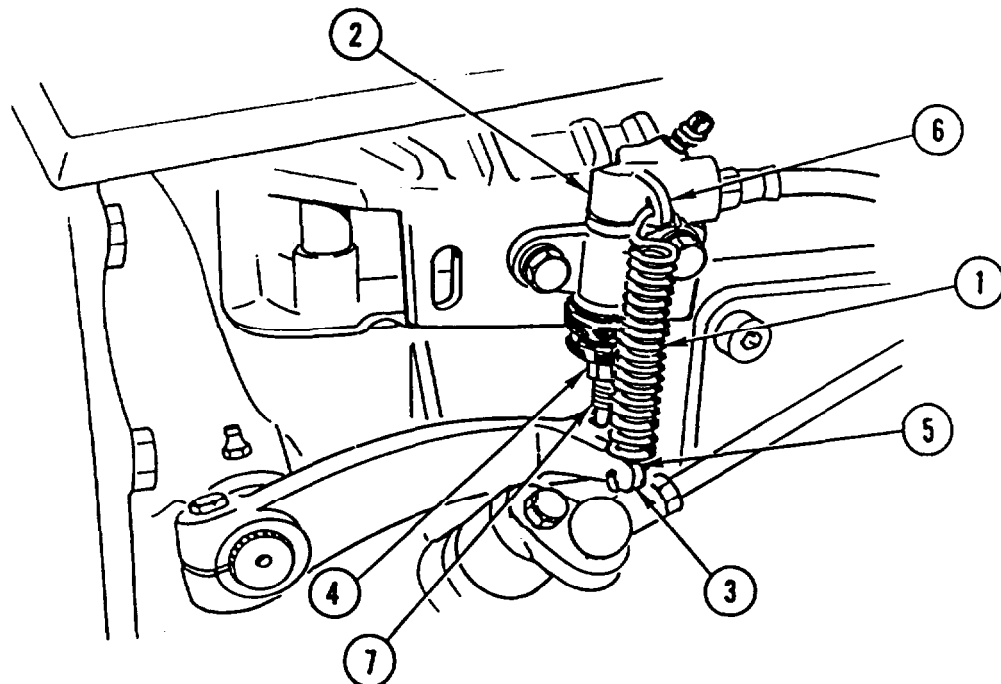

1. Remove spring (1) from clutch slave cylinder (2) and clutch lever (3).
2. Loosen lock nut (4).
3. Move clutch lever (3) down until it stops.
4. Insert a measuring device between clutch lever top surface (5) and bottom surface of spring bracket (6). Raise clutch lever (3). Movement of clutch lever must be 1/8 in. (3 ± 0.5 mm).
5. Turn adjusting pin (7) to adjust clearance. When proper clearance is obtained, tighten lock nut (4).
6. Attach spring (1) to clutch slave cylinder (2) and clutch lever (3).

NOTE

Follow-on Maintenance:

Lower cab (page 4-418).

CLUTCH MASTER CYLINDER REPLACEMENT

This task covers: a. Removal b. Installation

INITIAL SETUP

Tools and Special Equipment:

Shop Equipment, SC 4910-95-CL-A74
 Tool Kit, SC 5180-90-CL-N26

Equipment Condition:

Reference	Condition Description
Page 4-15	Clutch Hydraulic Reservoir Removed
Page 4-388	Outside Engine Hood Removed

Materials/Parts:

Washer, Lock (2)
 Caps and Plugs Appendix C, Item 7
 Rags Appendix C, Item 32

WARNING

Fuel and oil are slippery and can cause falls. To avoid injury, wipe up spilled fuel or oil with rags.

REMOVAL

CAUTION

Cap or plug all ports and ends of hoses and tubes to prevent contamination of hydraulic oil. Failure to do so may result in damage to equipment.

NOTE

Have container available to catch any fluid that may leak out of line or cylinder.

1. REMOVE LINE (1) from clutch master cylinder (2). INSTALL CAP or PLUG.
2. REMOVE two screws (3), two lock washers (4), and clutch master CYLINDER (2). DISCARD lock WASHERS.
3. FROM INSIDE CAB, REMOVE rubber protection BELLOWS (5) from end of clutch master cylinder (2).

CLUTCH MASTER CYLINDER REPLACEMENT (CONT)

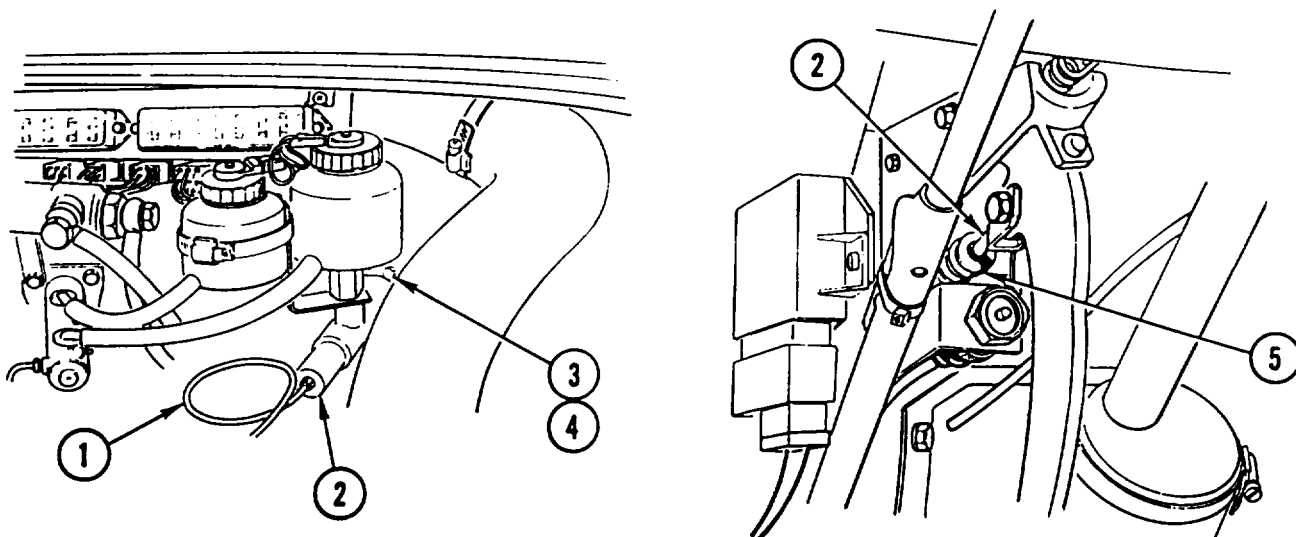
**INSTALLATION**

1. INSTALL clutch master CYLINDER (2), two screws (3), and two new lock washers (4).
2. REMOVE CAP or PLUG. INSTALL LINE (1) to clutch master cylinder (2).
3. FROM INSIDE CAB, INSTALL rubber protection BELLOWS (5) to end of clutch master cylinder (2).

NOTE

Follow-on Maintenance:

- Install clutch hydraulic reservoir (page 4-15).
- Bleed brake system (page 4-262).
- Install outside engine hood (page 4-388).

Section III. FUEL SYSTEM MAINTENANCE

OVERVIEW

This section illustrates and describes procedures for maintenance of the fuel system and related parts. A list of tasks contained in this section is shown below.

	Page
Fuel Injector Lines Replacement	4-25
Fuel Primer Pump Replacement	4-29
Hand Primer Replacement	4-31
Air Cleaner Replacement	4-32
Air Cleaner Filter Elements Replacement	4-35
Air Cleaner Ducts Replacement	4-38
Vertical Air Intake Pipe Replacement	4-39
Fuel Tank Draining	4-40
Fuel System Bleeding	4-41
Fuel Tank Replacement	4-42
Fuel Tank Lines and Fittings Replacement	4-44
Fuel Cap, Fittings, and Controls Replacement	4-47
Fuel Filter Element Replacement..	4-48
Fuel Filter Assembly Replacement and Repair	4-50
Fuel Filter Pre-Sediment Bowl and Filter Replacement	4-54
Cold Start Aid Replacement	4-55
Accelerator Pedal and Linkage Replacement	4-58
Accelerator Linkage Replacement..	4-64
Accelerator Linkage Adjustment..	4-68
Hand Throttle Replacement	4-70
Air Cylinder Replacement	4-72
Air Cylinder Replacement	4-74
Air Cylinder Adjustment	4-76
Air Cylinder Adjustment	4-77

FUEL INJECTOR LINES REPLACEMENT

This task covers: a. Removal b. Installation

INITIAL SETUP

Tools and Special Equipment:

Shop Equipment, SC 4910-95-CL-A74
 Tool Kit, SC 5180-90-CL-N26
 Socket, P/N FRXM17
 Wrench, P/N 000 589 07 03 00

Materials/Parts:

Rags Appendix C, item 32

Equipment Condition:

Reference	Condition Description
Page 4-3	Valve Cover Removed

General Safety Instructions:

WARNING

Diesel fuel is flammable. Do not perform this procedure near fire, flame, or sparks. Injury or death to personnel could result.

Fuel and oil are slippery and can cause falls. To avoid injury, wipe up spilled fuel or oil with rags.

REMOVAL

NOTE

- Procedure is the same for all lines.
- Tag lines prior to disconnecting to aid in connecting.
- Have container available to catch any fuel in injector lines.

1. USING WRENCH, DISCONNECT injector LINE (1) from injector pump (2).

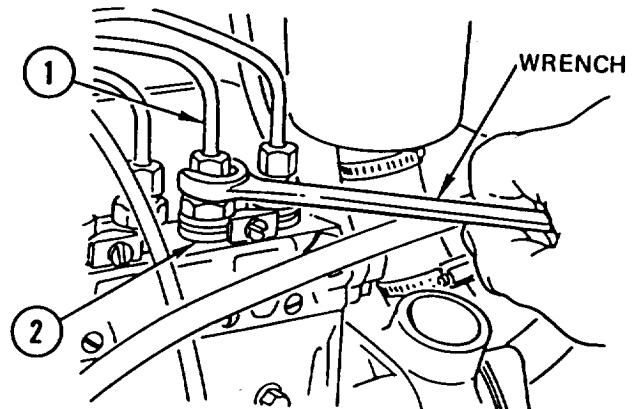

2. USING WRENCH, DISCONNECT injector LINE (1) from injector nozzle holder (3).

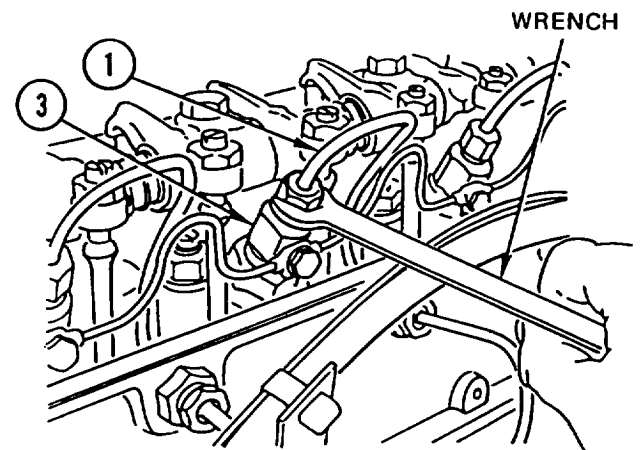

FUEL INJECTOR LINES REPLACEMENT (CONT)

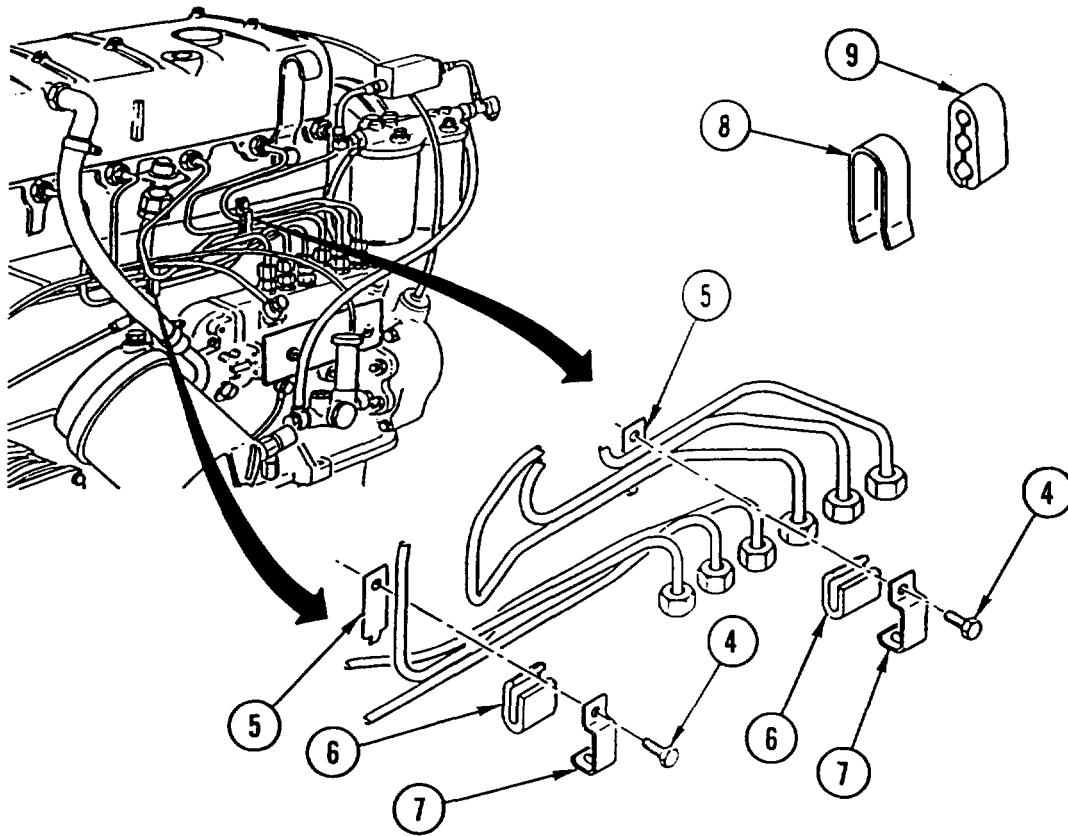

NOTE

- If your vehicle has a four-piece clamp (4, 5, 6, and 7), perform step 3.
- If your vehicle has a two-piece clamp (8 and 9), perform step 4.

3. REMOVE screw (4), shim (5), loop clamp (6), and CLAMP (7).
4. REMOVE BRACKET (8) and shim (9).

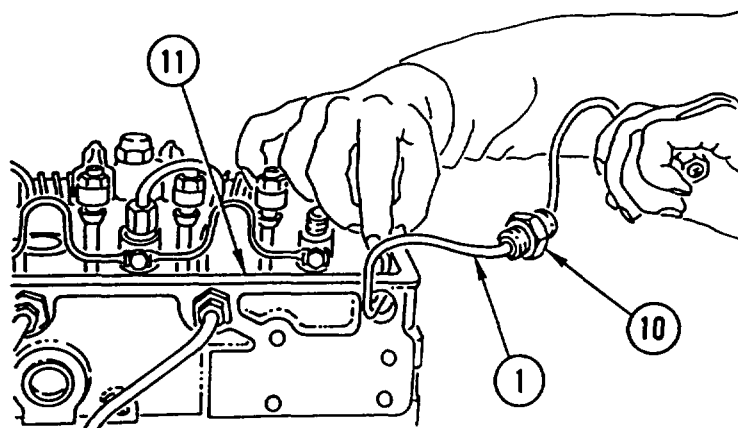

5. REMOVE NUT (10) from cylinder head (11) and REMOVE injector LINE (1).

FUEL INJECTOR LINES REPLACEMENT (CONT)

INSTALLATION

NOTE

Procedure is the same for all lines.

1. INSTALL injector LINE (1) through cylinder head (2).

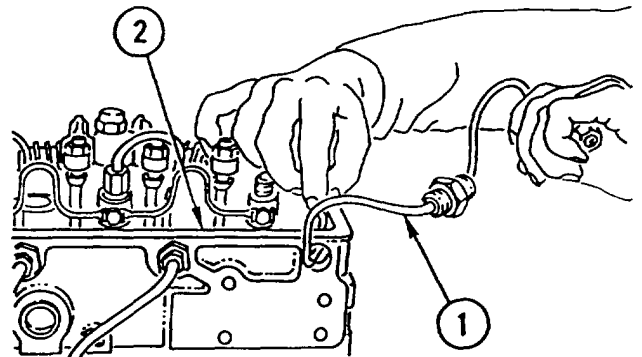

2. USING SOCKET, CONNECT injector LINE (1) to injector nozzle holder (3). USING SOCKET, TIGHTEN injector line NUT to 19 lb-ft (25 NŹm).
3. INSTALL NUT (4) in cylinder head (2).

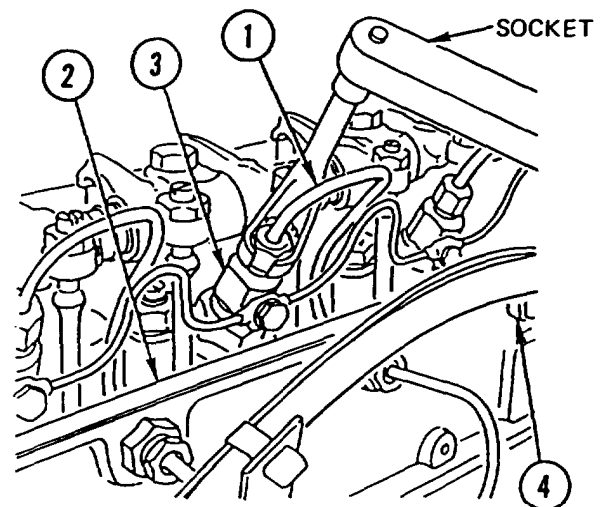

FUEL INJECTOR LINES REPLACEMENT (CONT)

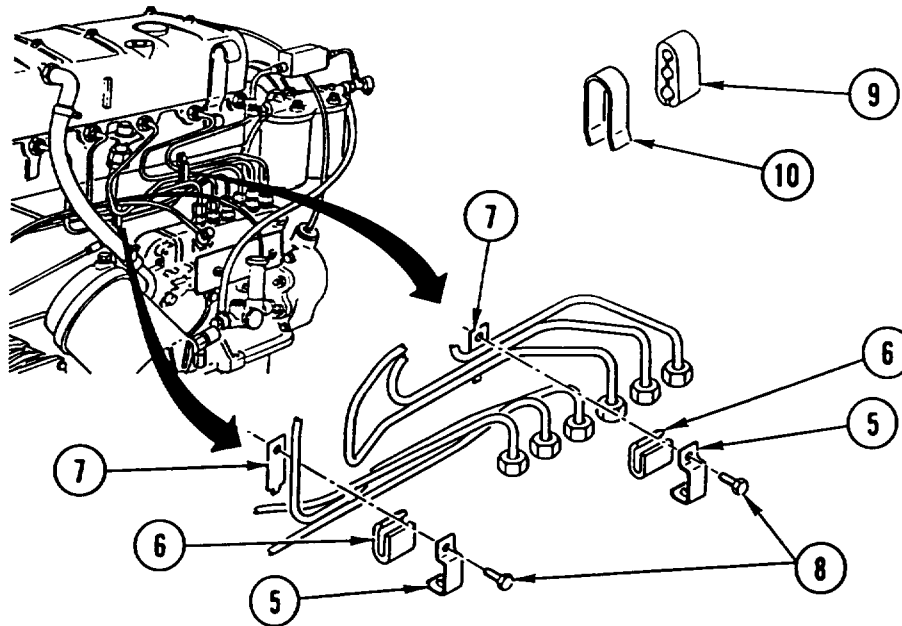

NOTE

- If your vehicle has a four-piece clamp (5, 6, 7, and 8), perform step 4.
- If your vehicle has a two-piece clamp (9 and 10), perform step 5.

4. INSTALL CLAMP (5), loop clamp (6), shim (7), and screw (8).
5. INSTALL shim (9) and BRACKET (10).

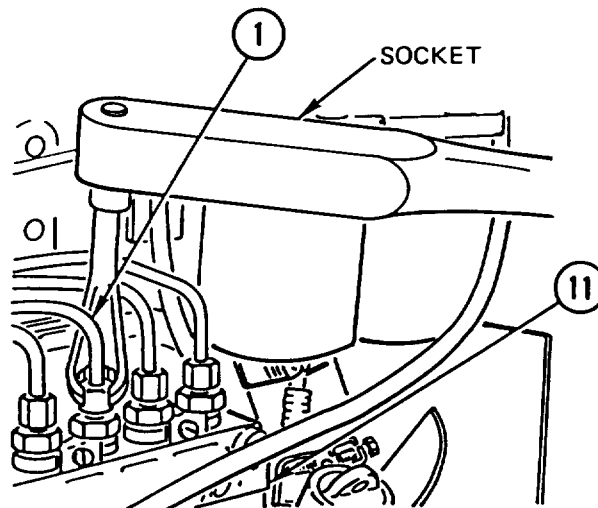

6. USING SOCKET, CONNECT injector LINE (1) to injector pump (11). USING SOCKET< TIGHTEN injector line NUT to 19 lb-ft (25 N•m).

NOTE

Follow-on Maintenance:

- Install valve cover (page 4-3).
- Bleed fuel system (page 4-41).

FUEL PRIMER PUMP REPLACEMENT

This task covers: a. Removal b. Installation

INITIAL SETUP

Tools and Special Equipment:

Shop Equipment, SC 4910-95-CL-A74
 Tool Kit, SC 5180-90-CL-N26

Materials/Parts:

Ring, Seal (4)
 Washer, Lock (3)
 Gasket

Equipment Condition:

Reference	Condition Description
Page 4-388	Outside Engine Hood Removed
Page 4-409	Right Front Fender and Splash Guard Removed

General Safety Instructions:

WARNING

Diesel fuel is flammable. Do not perform this procedure near fire, flame, or sparks. Injury or death to personnel could result.

REMOVAL

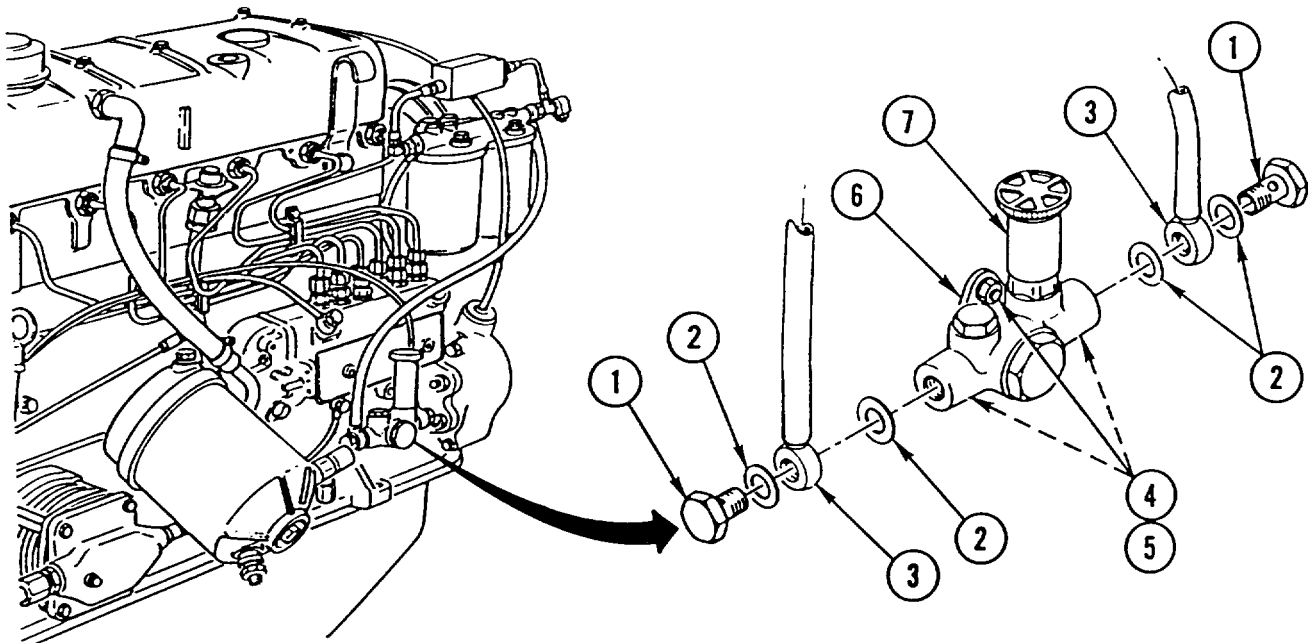

1. REMOVE two bolts (1) and four seal RINGS (2) from two unions (3). DISCARD seal RINGS.
2. REMOVE three nuts (4), three lock washers (5), gasket (6), and fuel primer PUMP (7). DISCARD lock WASHERS and GASKET.

FUEL PRIMER PUMP REPLACEMENT (CONT)

INSTALLATION

CAUTION

Make sure all gasket material has been removed from both timing device pump and fuel primer pump to prevent damage to equipment.

1. INSTALL new gasket (1), fuel primer PUMP (2), three new lock washers (3), and three nuts (4).

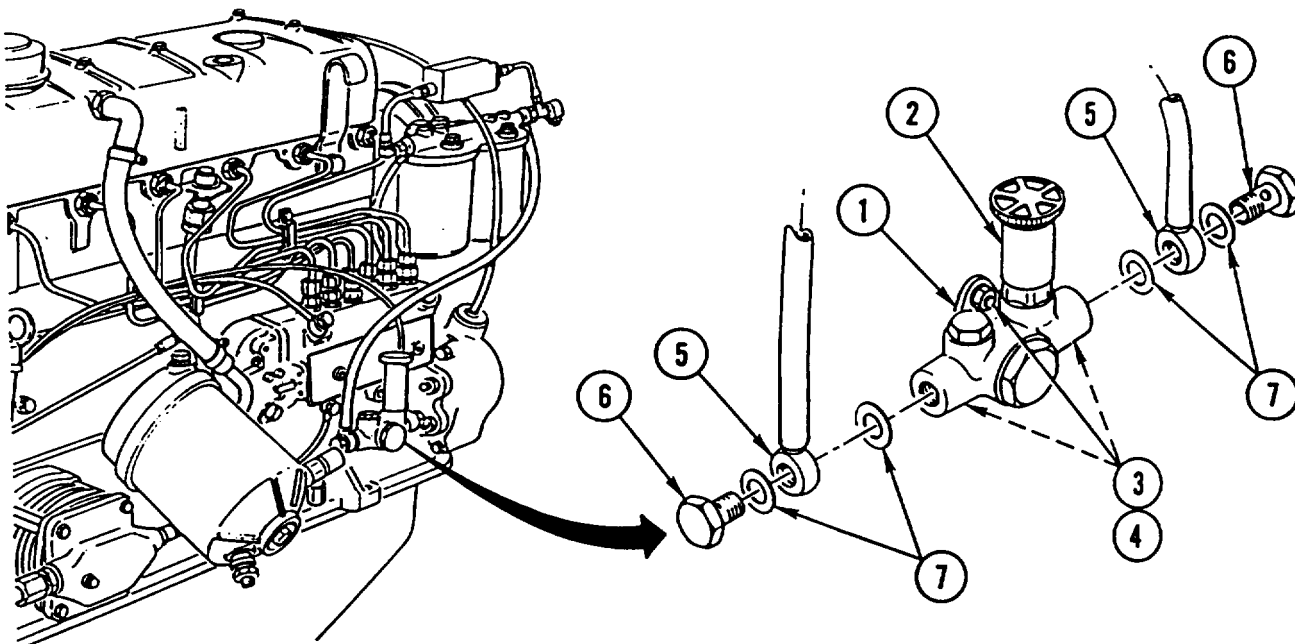

CAUTION

Make sure seal rings and packings are installed on both sides of unions to prevent damage to equipment.

2. INSTALL two UNIONS (5), two bolts (6), and four new seal rings (7).

NOTE

Follow-on Maintenance:

- Bleed fuel system (page 4-41).
- Install right front fender and splash guard (page 4-409).
- Install outside engine hood (page 4-388).

HAND PRIMER REPLACEMENT

This task covers: a. Removal b. Installation

INITIAL SETUP

Tools and Special Equipment:

Shop Equipment, SC 4910-95-CL-A74
 Tool Kit, SC 5180-90-CL-N26

Materials/Parts:

Packing

Equipment Condition:

Reference	Condition Description
Page 4-409	Right Front Fender and Splash Guard Removed

General Safety Instructions:

WARNING

Diesel fuel is flammable. Do not perform this procedure near fire, flame, or sparks. Injury or death to personnel could result.

REMOVAL

REMOVE hand primer HANDLE (1), packing (2), spring (3), and valve disk (4). DISCARD PACKING.

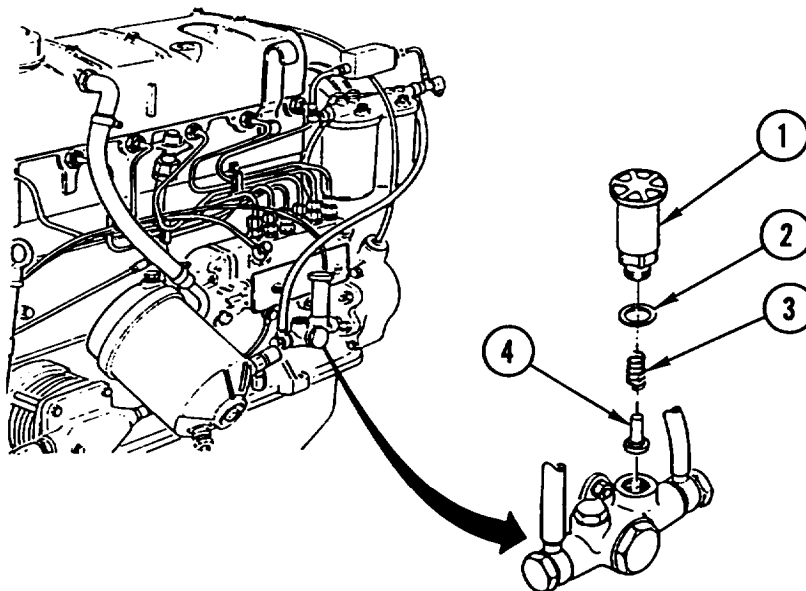

INSTALLATION

INSTALL valve disk (4), spring (3), new packing (2), and hand primer HANDLE (1).

NOTE

Follow-on Maintenance:

Bleed fuel system (page 4-41).
 Install right front fender and splash guard (page 4-409).

AIR CLEANER REPLACEMENT

This task covers: a. Removal b. Installation

INITIAL SETUP

Tools and Special Equipment:

Tool Kit, SC 5180-90-CL-N26

Materials/Parts:

Seal, Washer (2)

Washer, Lock (10)

Equipment Condition:

Reference	Condition Description
Page 4-388	Outside Engine Hood Removed

General Safety Instructions:

WARNING

Do not connect or disconnect any electrical connector unless vehicle MASTER disconnect switch is OFF. To do so could result in injury to personnel.

- If NBC exposure is suspected, all air filter media should be handled by personnel wearing protective equipment. Consult your unit NBC Officer or NBC NCO for appropriate handling or disposal instructions.

REMOVAL

- REMOVE wing nut and COVER (1).

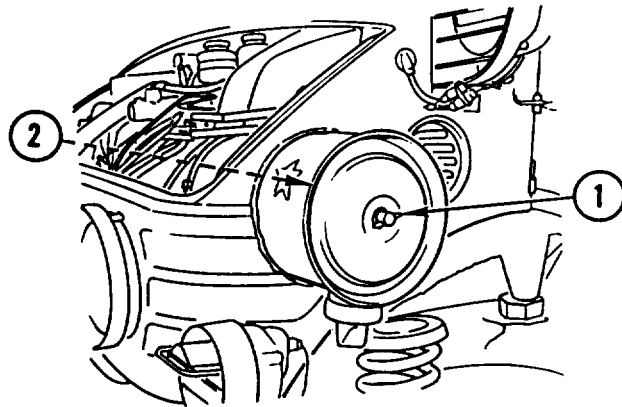

NOTE

Remove gasket (2) only if replacement is necessary.

- REMOVE wing nut (3), washer seal (4), and filter ELEMENT (5). DISCARD washer SEAL.

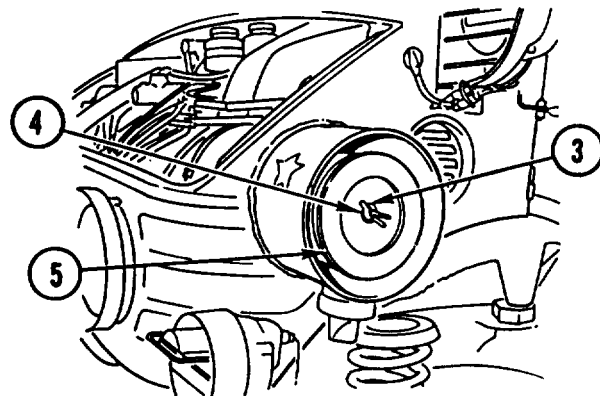

AIR CLEANER REPLACEMENT (CONT)

- REMOVE wing nut (6), washer seal (7), and filter ELEMENT (8). DISCARD washer SEAL.

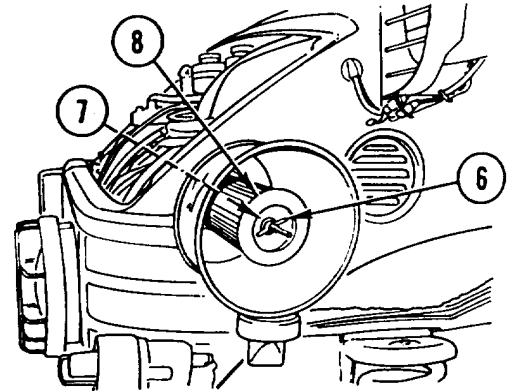

NOTE

Tag wires prior to disconnecting to aid in connecting.

- DISCONNECT two WIRES and REMOVE sender UNIT (9).
- DISCONNECT two HOSES (10 and 11).
- REMOVE two bolts (12) and two CLAMPS (13).
- REMOVE 10 screws (14), 10 lock washers (15), and BRACKET (16). DISCARD lock WASHERS.
- REMOVE valve (17) and air CLEANER (18).

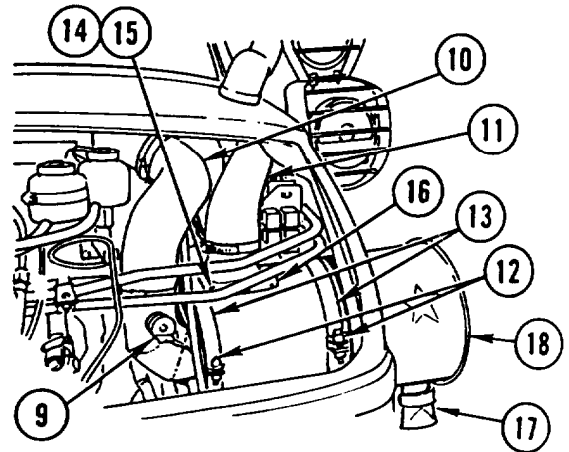

INSTALLATION

- INSTALL air CLEANER (1) and valve (2).
- INSTALL BRACKET (3), 10 screws (4), and 10 new lock washers (5).

NOTE

When installing clamps, make sure larger clamp is on the right.

- INSTALL two CLAMPS (6) and two bolts (7).
- CONNECT two HOSES (8 and 9).
- INSTALL sender UNIT (10) and CONNECT two WIRES.

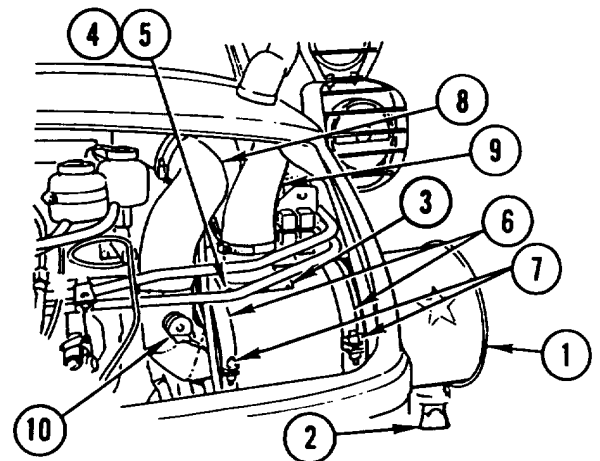

AIR. CLEANER REPLACEMENT (CONT)

6. INSTALL filter ELEMENT (11), new washer seal (12), and wing nut (13).

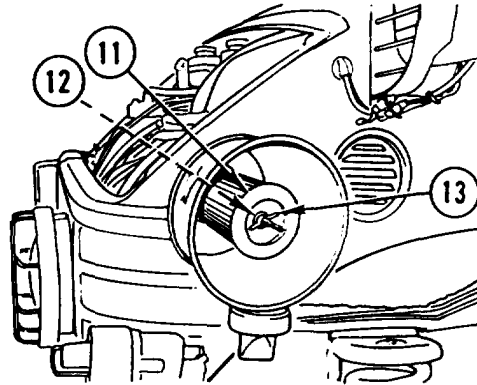

7. INSTALL filter ELEMENT (14), new washer seal (15), and wing nut (16).

CAUTION
If replacing gasket, make sure all gasket material and adhesive have been removed from cover to prevent damage to equipment.

NOTE

Make sure gasket is mounted evenly on cover.

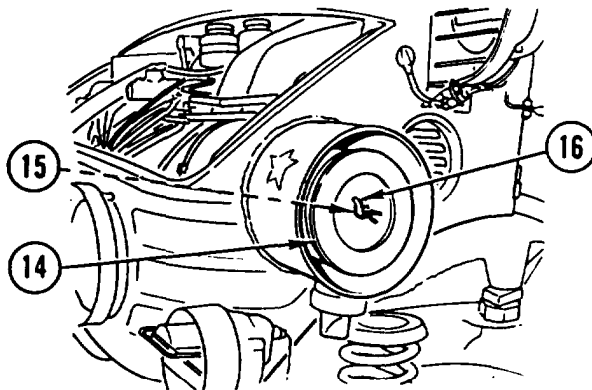

8. IF REMOVED, INSTALL new GASKET (17) on cover (18).

CAUTION
Make sure cover is securely seated to prevent damage to equipment.

INSTALL wing nut and COVER (18).

NOTE

Follow-on Maintenance:
Install outside engine hood (page 4-388).

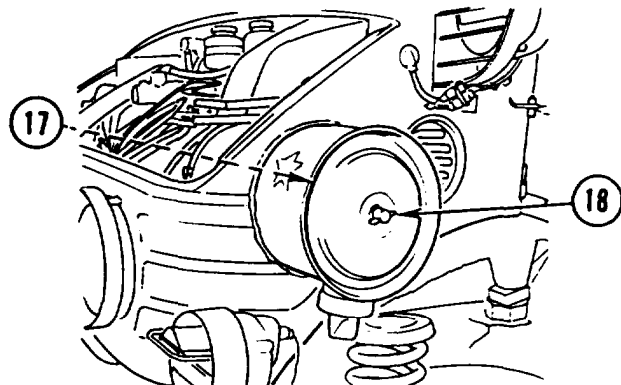

AIR CLEANER FILTER ELEMENTS SERVICING / REPLACEMENT

This task covers: a. Removal b. Inspection c. Cleaning d. Installation

INITIAL SETUP

Materials/Parts:

Element, Filter

Element, Filter

Tools and Special Equipment:

Shop Equipment, SC 4910-95-CL-A74

General Safety Instructions:

WARNING

If NBC exposure is suspected, all air filter media should be handled by personnel wearing protective equipment. Consult your unit NBC Officer or NBC NCO for appropriate handling or disposal instructions.

REMOVAL

1. LOOSEN wing NUT (1) and REMOVE COVER (2).

CAUTION

REPLACE both primary (outer) and safety (inner) filter elements after three cleanings or two years. Never clean safety (inner) filter. Damage to the filter may occur.

2. REMOVE wing nut (3) and primary (outer) filter ELEMENT (4).

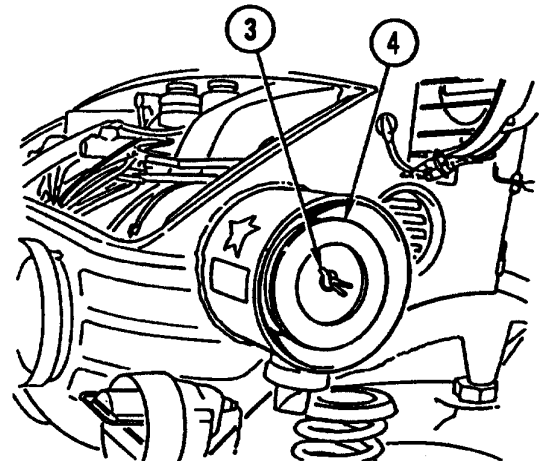
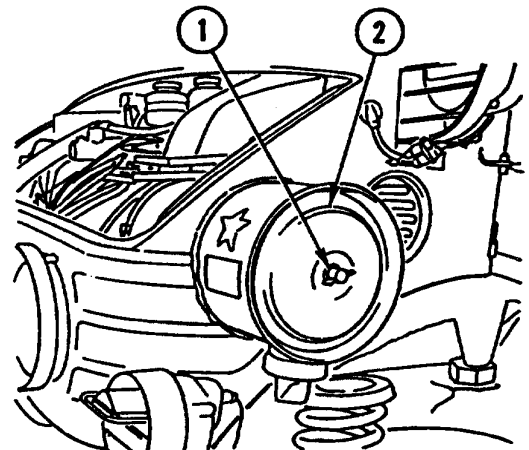

AIR CLEANER FILTER ELEMENTS SERVICING / REPLACEMENT (CONT)

CAUTION

Replace both primary (outer) and safety (inner) filter elements after three cleanings or two years. Never clean safety (inner) filter. Damage to filter may occur.

- REMOVE wing nut (5), washer (6), and safety (inner) filter ELEMENT (7). Discard filter ELEMENT.

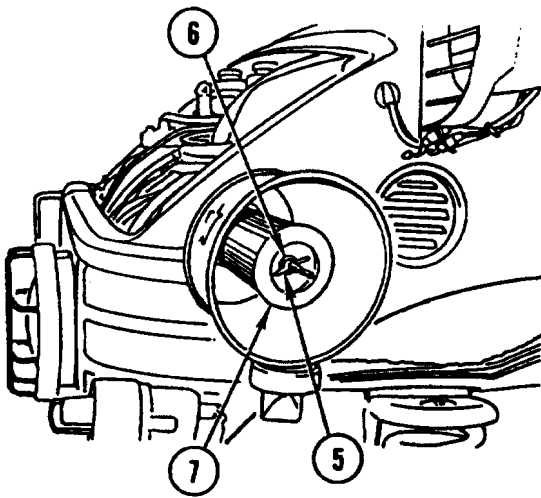

INSPECTION

- INSPECT entire AIR INTAKE SYSTEM. Pay particular attention to:
 - Gaskets and seals. Check for dents, tears, rips, and other damage.
 - Primary (outer) filter element. Inspect for holes and tears by looking through the element toward a bright light. If light shines through, replace both elements.

NOTE

Do not remove safety (inner) filter element unless replacing.

- Safety (inner) filter element. Visually inspect for damage.
- Housing components. Check for holes, dents, rust, or any other damage that will interfere with proper sealing and allow unfiltered air to enter and destroy engine.

CLEANING

WARNING

To prevent injury, compressed air used for cleaning purposes will not exceed 30 PSI (207 kPA). Use only with effective chip guarding and personal protection equipment (goggles/shields, gloves, etc.)

CAUTION

Replace both primary (outer) and safety (inner) filter elements after three cleanings or two years. Never clean safety (inner) filter element. Damage to filter may occur.

- Clean primary (outer) filter element with compressed air. Hold nozzle at least one inch away from element and direct compressed air against clean side of element (in direction opposite to normal air flow). Move air stream up and down length of pleats until dust cannot be seen blowing out.
- Annotate the date of filter cleaning on air filter elements.

INSTALLATION

- INSTALL new filter safety (inner) ELEMENT (1), washer (2), and wing nut (3).

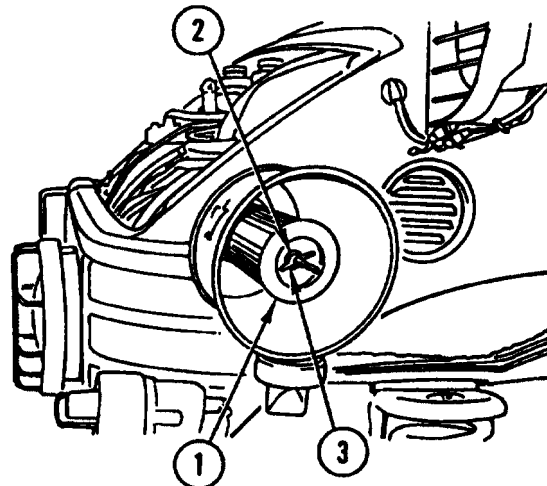

AIR CLEANER FILTER ELEMENTS SERVICING / REPLACEMENT (CONT)

2. INSTALL cleaned/new filter ELEMENT (4) and wing nut (5).

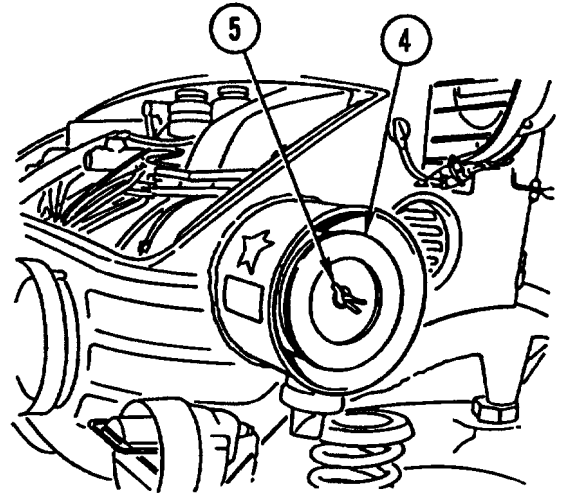

CAUTION

Make sure cover is securely seated to prevent damage to equipment.

3. INSTALL COVER (6) and TIGHTEN wing NUT (7).

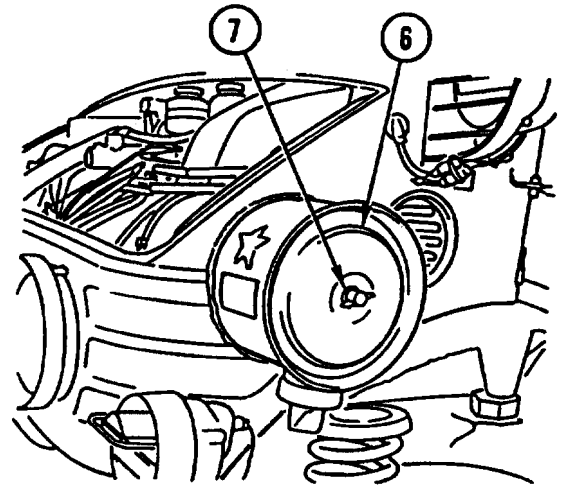

AIR CLEANER DUCTS REPLACEMENT

This task covers: a. Removal b. Installation

INITIAL SETUP

Tools and Special Equipment:

Tool Kit, SC 5180-90-CL-N26

Equipment Condition:

Reference

Page 4-388

Condition Description

Outside Engine Hood
Removed

REMOVAL

1. LOOSEN two CLAMPS (1) and REMOVE PIPE (2).
2. LOOSEN CLAMP (3) and REMOVE PIPE (4).
3. REMOVE start aid tube FITTING (5) and screw plug (6).
4. LOOSEN two CLAMPS (7) and REMOVE bellows (8) and intake PIPE (9).

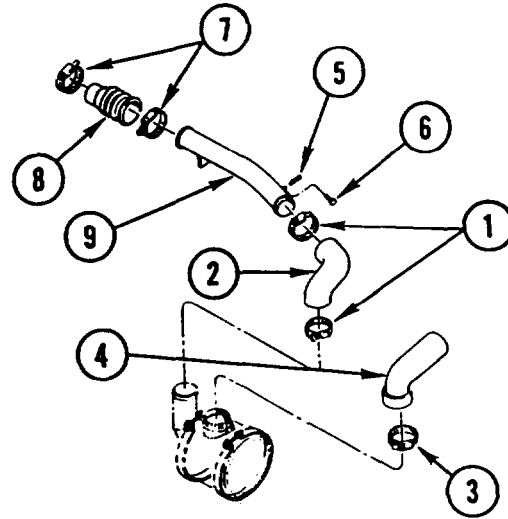
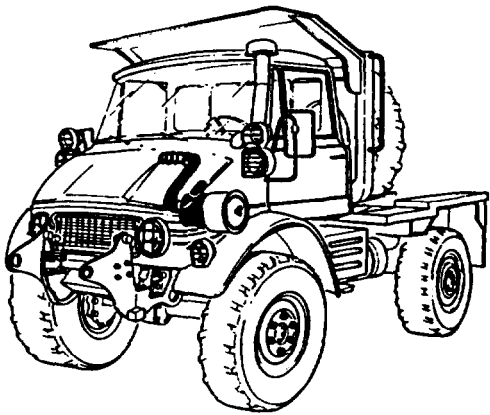

INSTALLATION

1. INSTALL intake PIPE (9) and bellows (8) and TIGHTEN two CLAMPS (7).
2. INSTALL screw plug (6) and start aid tube FITTING (5).
3. INSTALL PIPE (4) and TIGHTEN CLAMP (3).
4. INSTALL PIPE (2) and TIGHTEN two CLAMPS (1).

NOTE

Follow-on Maintenance:

Install outside engine hood (page 4-388).

VERTICAL AIR INTAKE PIPE REPLACEMENT

This task covers: a. Removal b. Installation

INITIAL SETUP

Tools and Special Equipment:

Tool Kit, SC 5180-90-CL-N26

Materials/Parts:

Washer, Spring
Tension (2)

REMOVAL

1. REMOVE nut (1), spring tension washer (2), washer (3), and SCREW (4). DISCARD spring tension WASHER.
2. REMOVE SCREW (5) and spring tension washer (6). DISCARD spring tension WASHER.
3. REMOVE CLAMP (7).
4. LOOSEN CLAMP (8) and REMOVE HOOD (9).
5. LOOSEN CLAMP (10) and REMOVE air intake PIPE (11).

INSTALLATION

1. INSTALL air intake PIPE (11) and TIGHTEN CLAMP (10).
2. INSTALL HOOD (9) and TIGHTEN CLAMP (8).
3. INSTALL CLAMP (7), screw (4), washer (3), new spring tension washer (2), and nut (1).
4. INSTALL SCREW (5) and new spring tension washer (6).

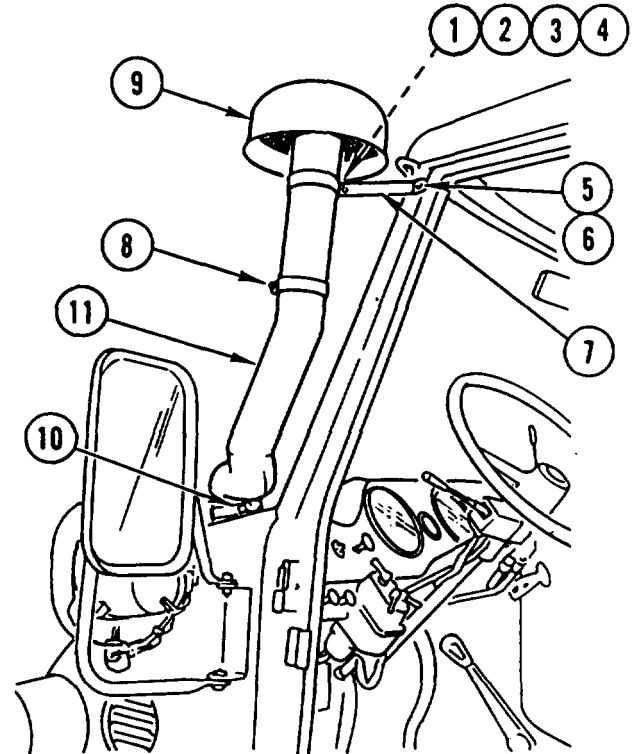

FUEL TANK DRAINING

This task covers: Draining

INITIAL SETUP

Tools and Special Equipment:

Shop Equipment, SC 4910-95-CL-A74
Tool Kit, SC 5180-90-CL-N26

Materials/Parts:

Rags Appendix C, Item 32

References:

TM 5-2420-224-10

General Safety Instructions:

WARNING

⚠ Diesel fuel is flammable. Do not perform this procedure near fire, flame, or sparks. Injury or death to personnel could result.

- Fuel and oil are slippery and can cause falls. To avoid injury, wipe up spilled fuel or oil with rags.

DRAINING

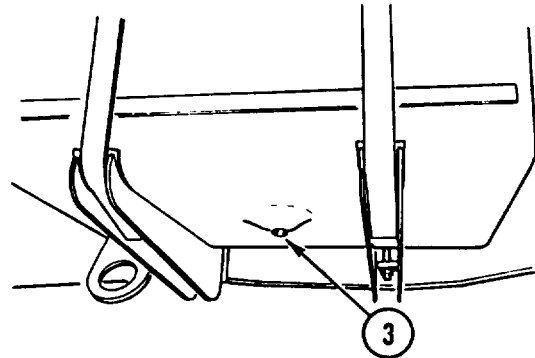
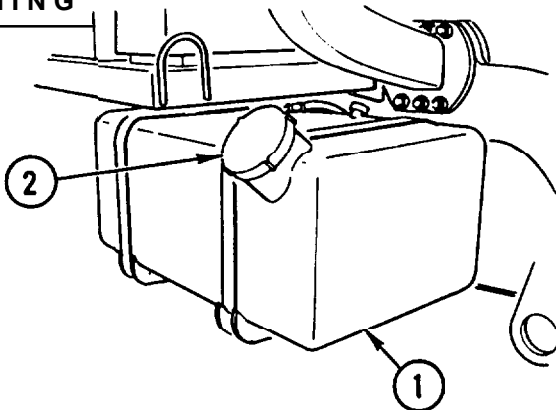

1. Place 30-gallon (114-liter) or larger container under fuel tank (1).
2. Remove fuel tank filler cap (2).
3. Close fuel shutoff valve (TM 5-2420-224-10).
4. Remove drain plug (3).
5. Flush fuel tank (1) with clean fuel.
6. Install drain plug (3).
7. Fill fuel tank (1) with clean fuel.
8. Install fuel tank filler cap (2).
9. Open fuel shutoff valve (TM 5-2420 -224-10).

FUEL SYSTEM BLEEDING

This task covers: Bleeding

INITIAL SETUP

Tools and Special Equipment:

Shop Equipment, SC4910-95-CL-A74
Tool Kit, SC 5180-90-CL-N26

Equipment Condition:

Reference	Condition Description
Page 4-388	Outside Engine Hood Removed

General Safety Instructions:

WARNING

Diesel fuel is flammable. Do not perform this procedure near fire, flame, or sparks. Injury or death to personnel could result.

BLEEDING

1. Loosen front bleed screw (1) approximately two turns.
2. Unscrew hand pump (2). Pump hand pump (2) until fuel runs free of bubbles from bore of front bleed screw (1).
3. Tighten front bleed screw (1).
4. Loosen rear bleed screw (3) approximately two turns.
5. Pump hand pump (2) until fuel runs free of bubbles from bore of rear bleed screw (3).
6. Tighten rear bleed screw (3).
7. Push down on hand pump (2) and turn to lock in place.

NOTE:

Follow-on Maintenance:
Install outside engine hood (page 4-388).

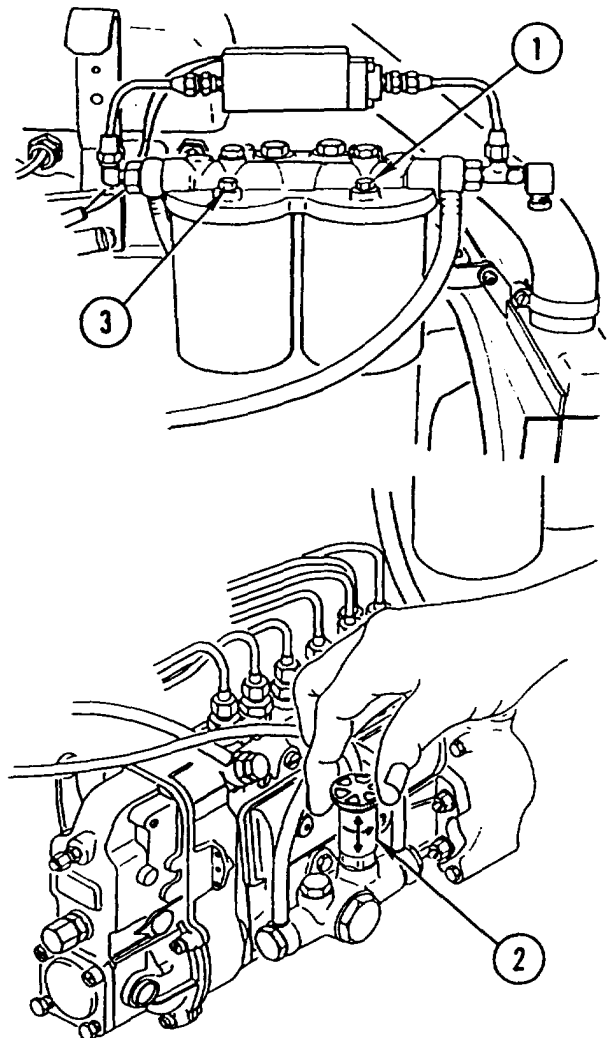

FUEL TANK REPLACEMENT

This task covers: a. Removal b. Installation

INITIAL SETUP

Tools and Special Equipment:

Tool Kit, SC 5180-90-CL-N26

Personnel Required: (2)

Equipment Condition:

Reference	Condition Description
Page 4-40	Fuel Tank Drained

General Safety Instructions:

WARNING

- Do not connect or disconnect any electrical connector unless vehicle MASTER disconnect switch is OFF. To do so could result in injury to personnel.
- Fuel tank weighs 58 pounds (26 kilograms). To avoid personal injury, use a hoist or suitable lifting device when lifting fuel tank.

REMOVAL

1. LOOSEN two NUTS (1).

NOTE

Tag lines prior to removal to aid in installation.

2. SLIDE fuel TANK (2) forward and LOOSEN two clamp SCREWS (3). REMOVE two HOSES (4), nut (5), and electrical CONNECTOR (6).

NOTE

Aluminum replacement fuel tank has isolators on tank straps and supports.

3. REMOVE two nuts (1), two washers (7), two STRAPS (8), and two isolators (9).
4. REMOVE fuel TANK (2).

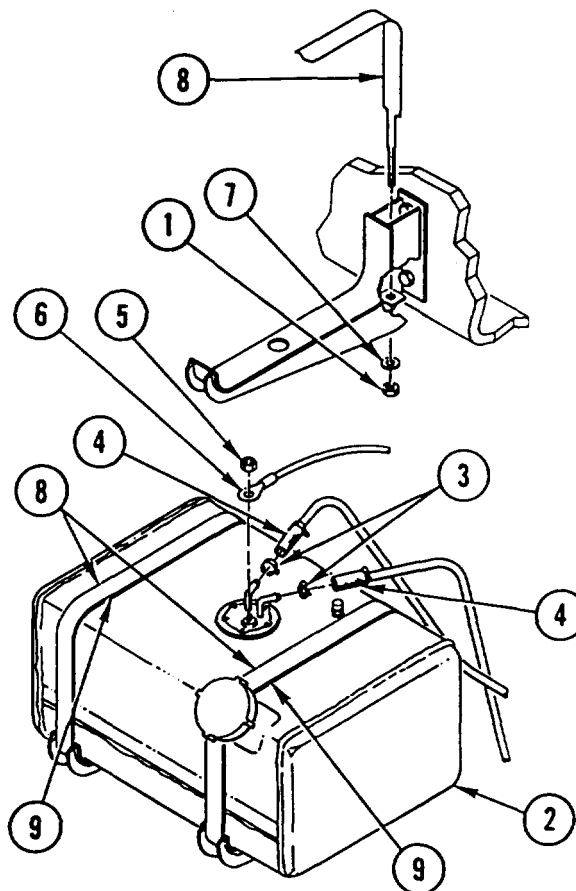

FUEL TANK REPLACEMENT (CONT)

INSTALLATION

1. INSTALL fuel TANK (1) until supported by supports (2).
2. INSTALL two isolators (3), two STRAPS (4), two washers (5), and two nuts (6). DO NOT TIGHTEN NUTS.
3. INSTALL two HOSES (7). TIGHTEN two clamp SCREWS (8) and INSTALL electrical CONNECTOR (9) and nut (10).
4. SLIDE fuel TANK (1) into position and TIGHTEN two NUTS (6).

NOTE

Follow-on Maintenance:
Fill fuel tank (page 4-40).

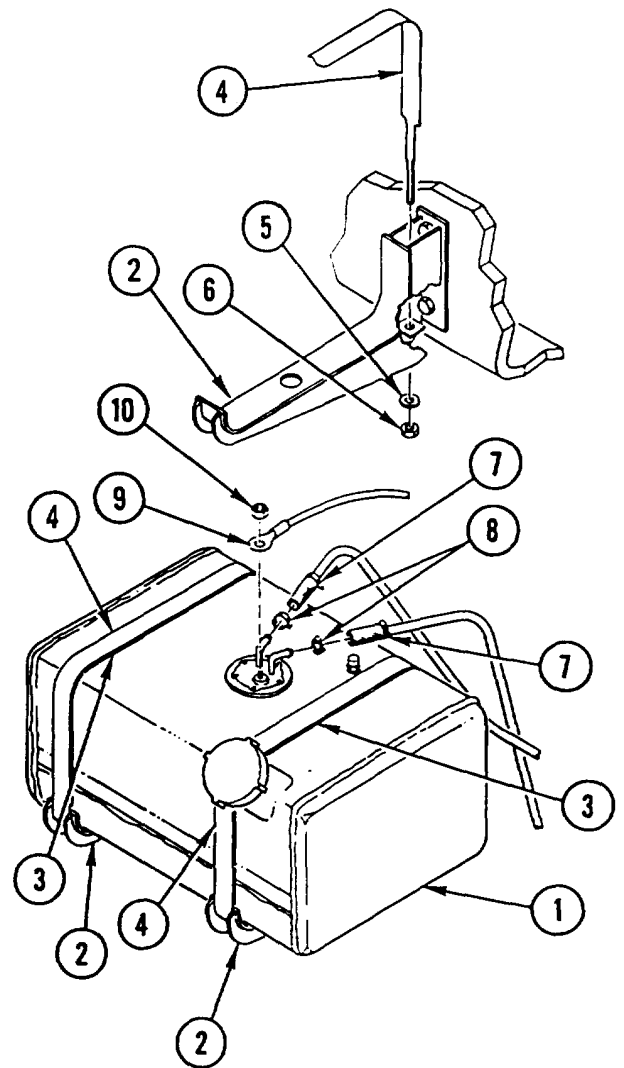

FUEL TANK LINES AND FITTINGS REPLACEMENT

This task covers: a. Removal b. Installation

INITIAL SETUP

Tools and Special Equipment:

Shop Equipment, SC 4910-95-CL-A74
 Tool Kit; SC 5180-90-CL-N26

General Safety Instructions:

WARNING

- Do not connect or disconnect any electrical connector unless vehicle MASTER disconnect switch is OFF. To do so could result in injury to personnel.
- Fuel and oil are slippery and can cause falls. To avoid injury, wipe up spilled fuel or oil with rags.

Materials/Parts:

Ring, Seal (2)
 Strap, Retaining (10)
 Rags Appendix C, Item 32

Equipment Condition:

Reference	Condition Description
Page 4-389	Inside Engine Hood Removed

REMOVAL

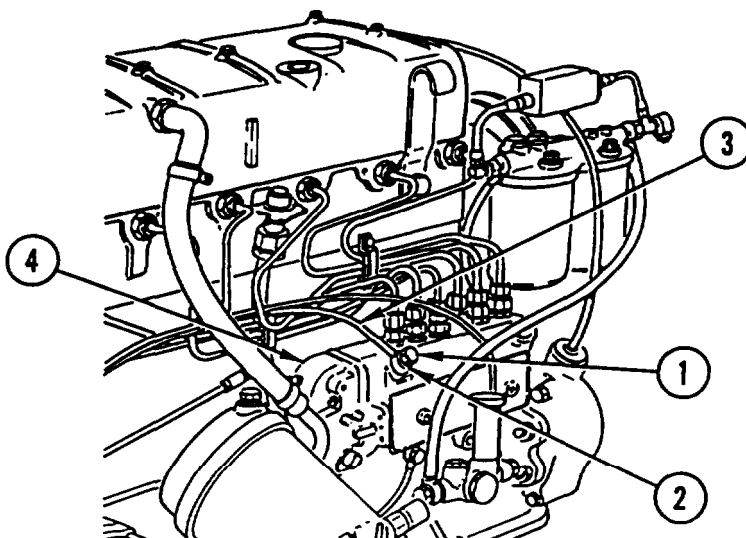

NOTE

Tag all lines prior to removal to aid in installation.

1. REMOVE hollow screw (1), two seal rings (2), and fuel LINE (3) from rear of injector pump (4). DISCARD seal RINGS.

FUEL TANK LINES AND FITTINGS REPLACEMENT (CONT)

2. REMOVE and DISCARD six retaining STRAPS (5).
3. REMOVE mounting nut (6) and BOLT (7) from pre-sediment fitter (8).
4. REMOVE fitting NUT (9).
5. REMOVE fitting NUT (10).

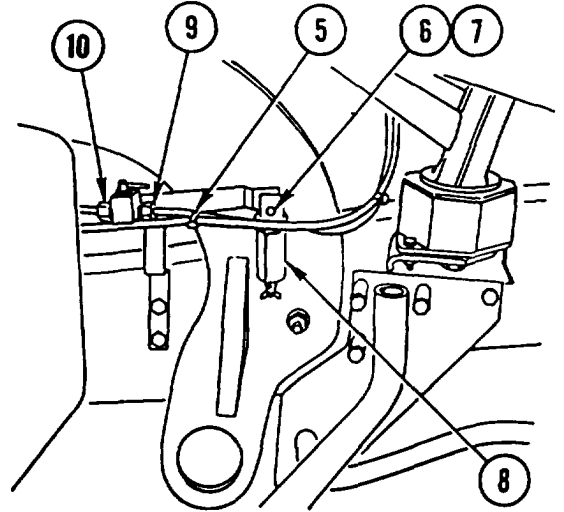

6. REMOVE and DISCARD four retaining STRAPS (11).
7. LOOSEN SCREW (12) from clamp (13).
8. REMOVE fuel LINE (14) from fuel level indicator (15).

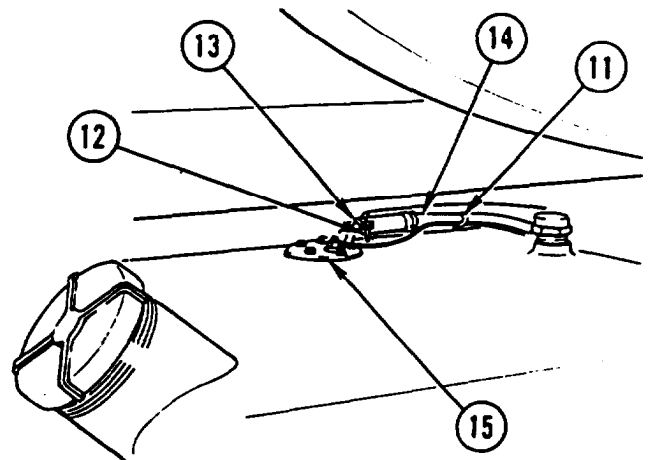

INSTALLATION

1. INSTALL fuel LINE (1) on fuel level indicator (2).
2. TIGHTEN SCREW (3) on clamp (4).
3. INSTALL four new retaining STRAPS (5).

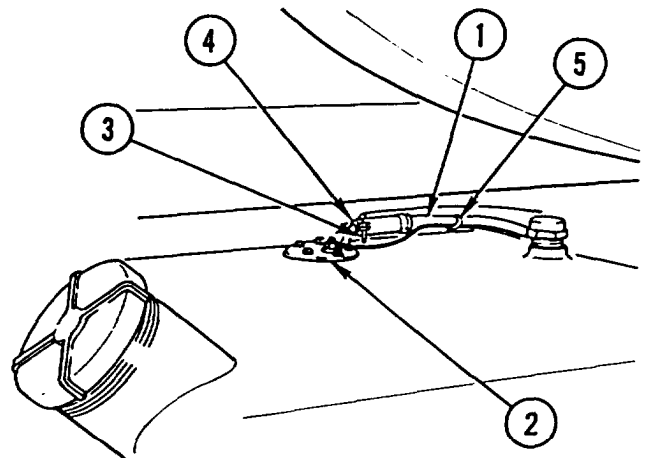

FUEL TANK LINES AND FITTINGS REPLACEMENT (CONT)

4. INSTALL fitting NUT (6).
5. INSTALL fitting NUT (7).
6. INSTALL mounting nut (8) and BOLT (9) on pre-sediment filter (10).
7. INSTALL six new retaining STRAPS (11).

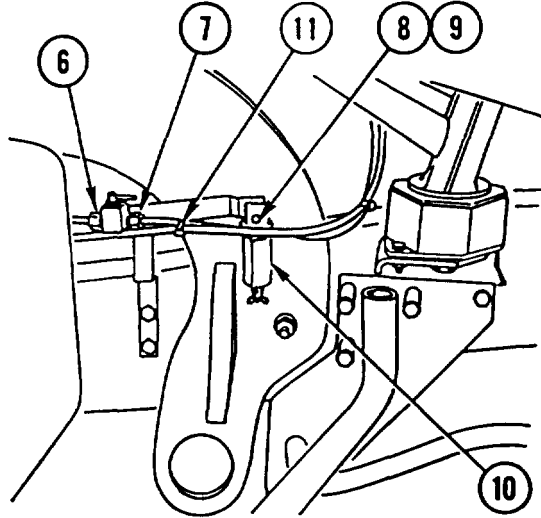

8. INSTALL fuel LINE (12), two new seal rings (13), and hollow screw (14) on rear of injector pump (15).

NOTE

Follow-on Maintenance:
Bleed fuel system (page 4-41).
Install inside engine hood (page 4-389).

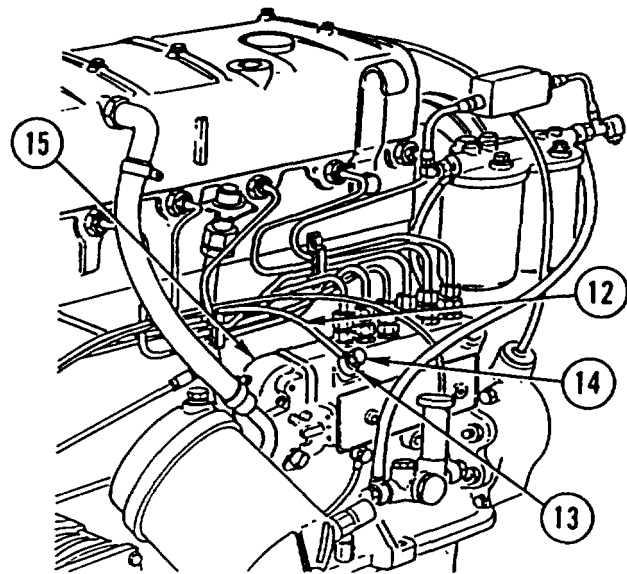

FUEL CAP, FITTINGS, AND CONTROLS REPLACEMENT

This task covers: a. Removal b. Installation

INITIAL SETUP

Tools and Special Equipment:

Shop Equipment, SC 4910-95-CL-A74
 Tool Kit, SC 5180-90-CL-N26

Materials/Parts:

Nut, Lock

REMOVAL

1. REMOVE cap (1) and STRAINER (2) from tank (3).
2. IF DAMAGED, REMOVE GASKET (4).
3. REMOVE "S" HOOK (5) from strainer (2).
4. DISCONNECT inlet LINE (6) and outlet LINE (7) from shutoff valve (8).
5. REMOVE screw (9), lock nut (10), and shutoff VALVE (8). DISCARD lock NUT.

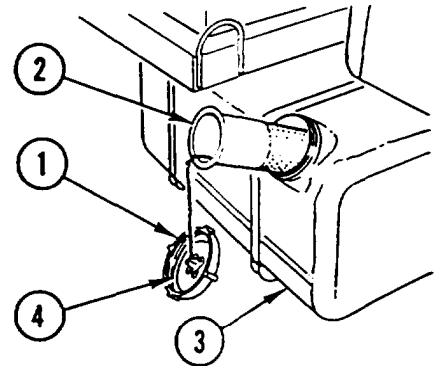

INSTALLATION

1. INSTALL shutoff VALVE (8), screw (9), and new lock nut (10).
2. CONNECT inlet LINE (6) and outlet LINE (7) to shutoff valve (8).
3. INSTALL "S" HOOK (5) on strainer (2).
4. IF REMOVED, INSTALL new GASKET (4).
5. INSTALL STRAINER (2) and cap (1) in tank (3).

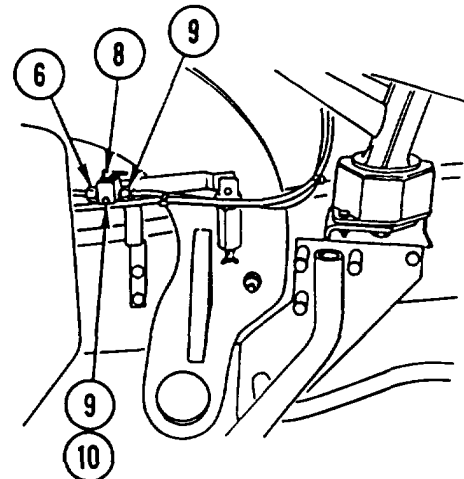
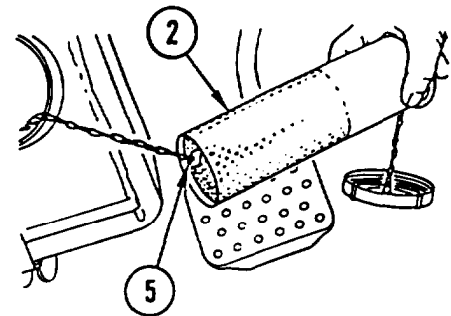

FUEL FILTER ELEMENT REPLACEMENT

This task covers: a. Removal b. Installation

INITIAL SETUP

Tools and Special Equipment:

Shop Equipment, SC 4910-95-CL-A74
Tool Kit, SC 5180-90-CL-N26

Materials/Parts:

Seal
Element, Filter
Ring, Seal
Fuel, Diesel Appendix C, Item 18

Equipment Condition:

Reference	Condition Description
Page 4-388	Outside Engine Hood Removed

General Safety Instructions:

<p style="text-align: center;">WARNING</p> <p>Diesel fuel is flammable. Do not perform this procedure near fire, flame, or sparks. Injury or death to personnel could result.</p>
--

REMOVAL

NOTE

Procedure is the same for both filters.

1. REMOVE screw (1), seal (2), and element HOUSING (3). DISCARD SEAL.
2. REMOVE and DISCARD filter ELEMENT (4).
3. REMOVE seal RING (5) from filter head (6). DISCARD seal RING.

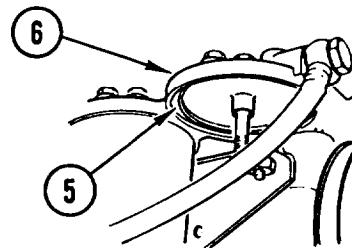
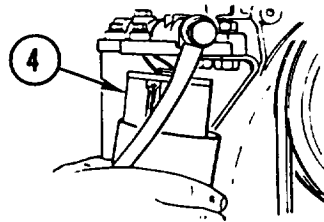
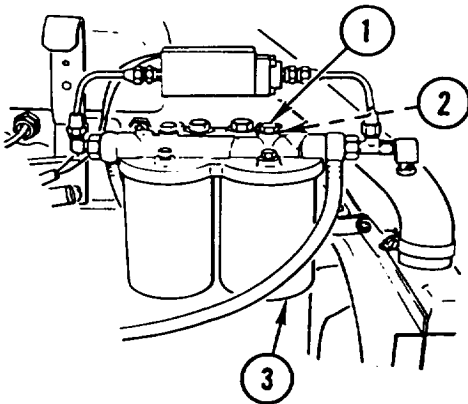

FUEL FILTER ELEMENT REPLACEMENT (CONT)

INSTALLATION**NOTE**

Procedure is the same for both filters.

1. INSTALL new seal RING (5) in filter head (6).
2. INSTALL new filter ELEMENT (4) in element housing (3). FILL HOUSING (3) with clean diesel fuel.
3. INSTALL element HOUSING (3) on filter head (6) and INSTALL screw (1) and new SEAL (2).

NOTE

Follow-on Maintenance:

Bleed fuel system (page 4-41).

Install outside engine hood (page 4-388).

FUEL FILTER ASSEMBLY REPLACEMENT AND REPAIR

This task covers: a. Removal b. Disassembly c. Assembly d. Installation

INITIAL SETUP

Tools and Special Equipment:

Shop Equipment, SC 4910-95-CL-A74
Tool Kit, SC 5180-90-CL-N26

Materials/Parts:

Packing (4)

Washer, Spring
Tension (2)

Washer, Lock (2)

Seal (2)

Seal (2)

Ring, Seal (2)

Rags

Appendix C, Item 32

References:

TM 5-2420-224-10

Equipment Condition:

Reference

TM 5-2420-224-10

Page 4-388

Condition Description

Fuel Shutoff Valve
Closed

Outside Engine Hood
Removed

General Safety Instructions:

W A R N I N G

- Diesel fuel is flammable. Do not perform this procedure near fire, flame, or sparks. Injury or death to personnel could result.
- Fuel and oil are slippery and can cause falls. To avoid injury, wipe up spilled fuel or oil with rags.

FUEL FILTER ASSEMBLY REPLACEMENT AND REPAIR (CONT)

REMOVAL

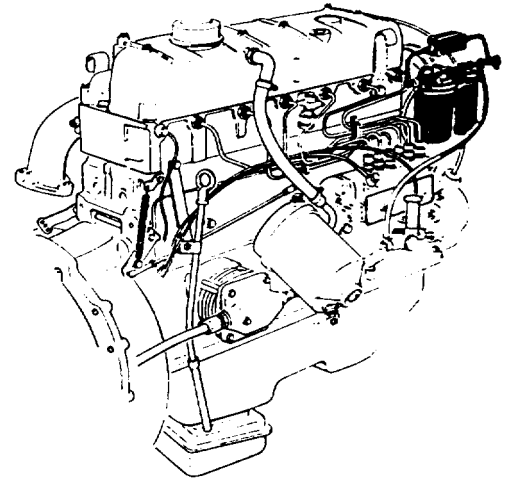

NOTE

Have container available to catch any fuel in fuel lines.

1. LOOSEN two NUTS (1) and REMOVE SWITCH (2).
2. REMOVE two screws (3) with fittings attached, four packings (4), and two UNIONS (5). DISCARD PACKINGS.
3. REMOVE two screws (6), two spring tension washers (7), and filter HEAD (8). DISCARD spring tension WASHERS.

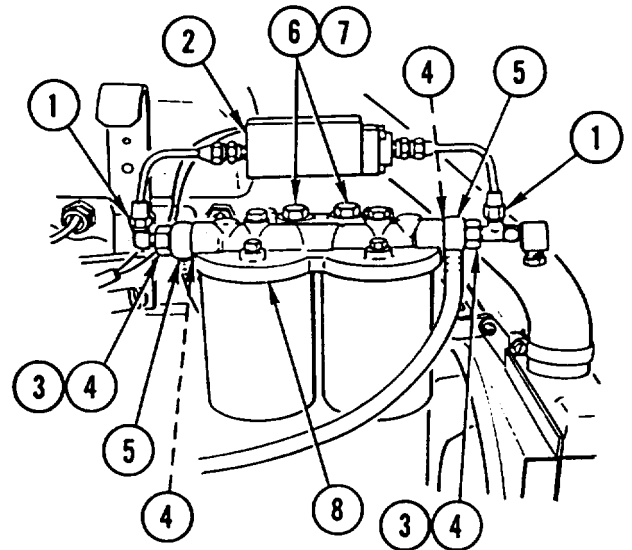

4. REMOVE two screws (9), two lock washers (10), and BRACKET (11). DISCARD lock WASHERS.

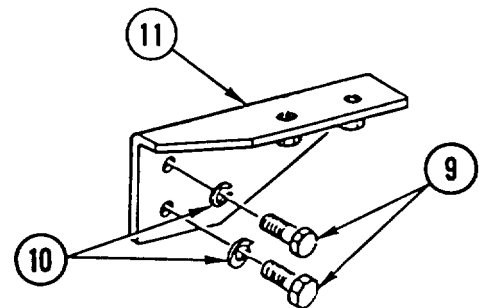

FUEL FILTER ASSEMBLY REPLACEMENT AND REPAIR (CONT)

DISASSEMBLY

1. REMOVE two screws (1), two seals (2), and two element HOUSINGS (3). DISCARD SEALS.
2. REMOVE two filter ELEMENTS (4) from two element housings (3).
3. REMOVE two screws (5) and two SEALS (6). DISCARD SEALS.
4. REMOVE two seal RINGS (7) from filter head (8). DISCARD seal RINGS.

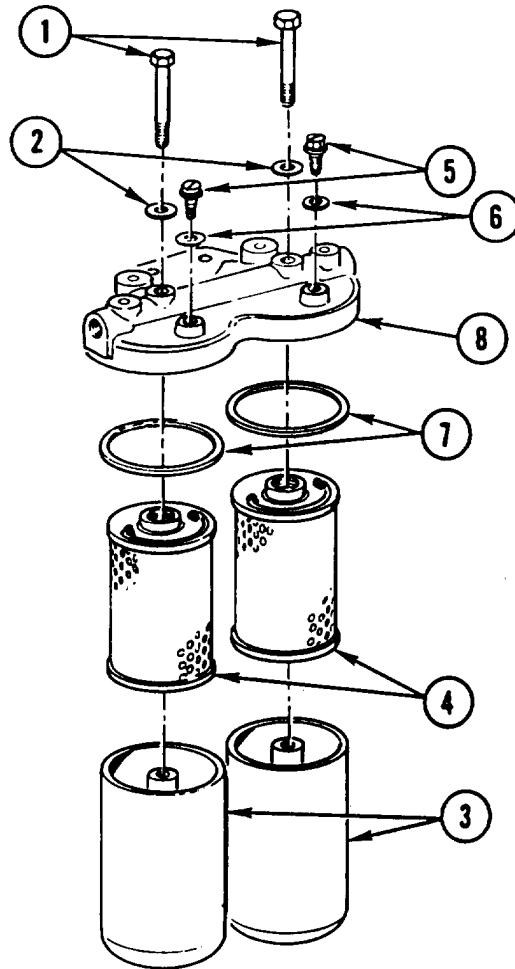

ASSEMBLY

1. INSTALL two new seal RINGS (7) in filter head (8).
2. INSTALL two screws (5) and two new SEALS (6).
3. INSTALL two filter ELEMENTS (4) in two element housings (3).
4. INSTALL two element HOUSINGS (3) in filter head (8) and INSTALL two screws (1) and two new SEALS (2).

INSTALLATION

1. INSTALL BRACKET (1), two screws (2), and two new lock washers (3).
2. INSTALL filter HEAD (4), two screws (5), and two new spring tension washers (6).

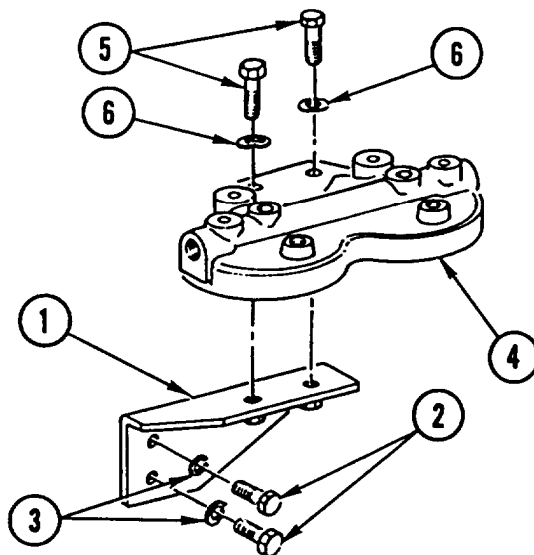

FUEL FILTER ASSEMBLY REPLACEMENT AND REPAIR (CONT)

NOTE

Place packings on both sides of unions.

3. INSTALL four new packings (7), two UNIONS (8), and two screws (9).
4. INSTALL SWITCH (10) and TIGHTEN two NUTS (11).

NOTE

Follow-on Maintenance:

Open fuel shutoff valve (TM 5-2420-224-10).
Bleed fuel system (page 4-41).
Install outside engine hood (page 4-388).

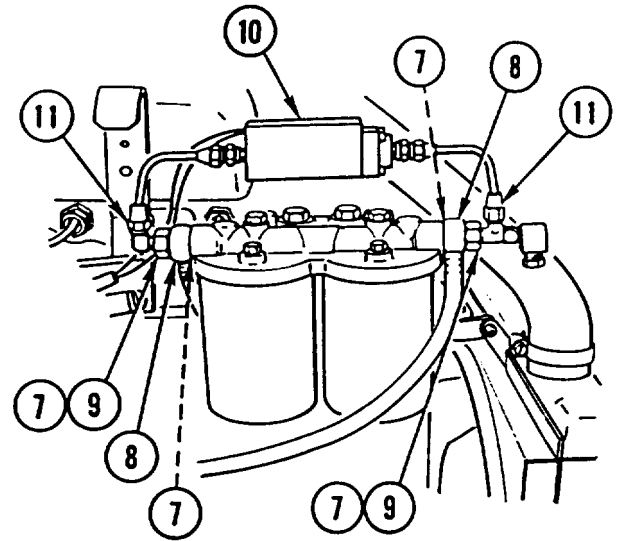

FUEL FILTER PRE-SEDIMENT BOWL AND FILTER REPLACEMENT

This task covers: a. Removal b. Installation

INITIAL SETUP

Tools and Special Equipment:

Shop Equipment, SC 4910-95-CL-A74
Tool Kit, SC 5180-90-CL-N26

Materials/Parts:

Gasket

Nut, Lock

Fuel, Diesel

Appendix C, Item 18

General Safety Instructions:

WARNING

Diesel fuel is flammable. Do not perform this procedure near fire, flame, or sparks. Injury or death to personnel could result.

REMOVAL

1. LOOSEN wing NUT (1) and REMOVE BRACKET (2).
2. REMOVE filter pre-sediment BOWL (3).
3. IF DAMAGED, REMOVE filter ELEMENT (4).
4. REMOVE GASKET (5) from housing (6). DISCARD GASKET.
5. DISCONNECT two HOSES (7).
6. REMOVE mounting screw (8), lock nut (9), and HOUSING (6). DISCARD lock NUT.

INSTALLATION

1. INSTALL HOUSING (6), mounting screw (8), and new lock nut (9).
2. CONNECT two HOSES (7) to housing (6).
3. INSTALL new GASKET (5) in housing (6).
4. IF REMOVED, INSTALL new filter ELEMENT (4) in filter pre-sediment bowl (3). FILL BOWL (3) with clean diesel fuel.
5. INSTALL BOWL (3) and bracket (2) and TIGHTEN wing NUT (1).

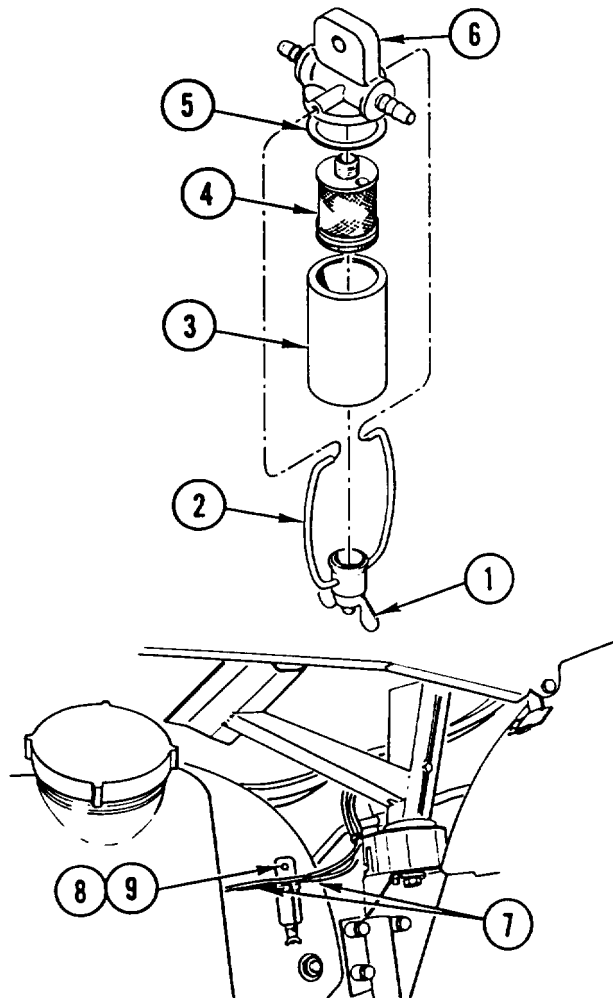

COLD START AID REPLACEMENT

This task covers: a. Removal b. Installation

INITIAL SETUP

Tools and Special Equipment:

Tool Kit, SC 5180-90-CL-N26

Materials/Parts:

Washer, Lock

Nut, Lock (4)

Seal

Equipment Condition:

Reference	Condition Description
Page 4-388	Outside Engine Hood Removed

General Safety Instructions:

WARNING

Do not work on cold start aid system in presence of sparks or open flame. To do so could result in injury to personnel.

REMOVAL

1. OPEN CLAMP (1) completely.

CAUTION

Lift cartridge out carefully so that threads are not damaged.

2. REMOVE CARTRIDGE (2) from switch (3).

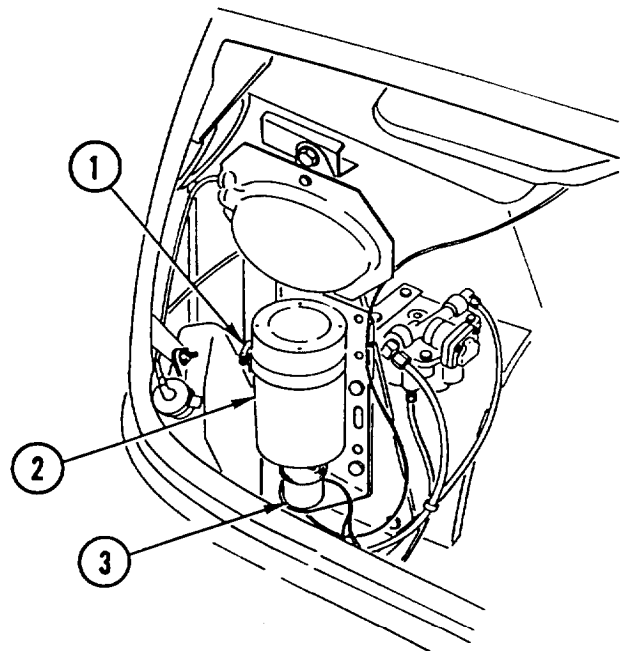

COLD START AID REPLACEMENT (CONT)

3. DISCONNECT SWITCH (3) from engine temperature sender at terminal (4).
4. REMOVE nut (5), lock washer (6), and ground WIRE (7). DISCARD lock WASHER.

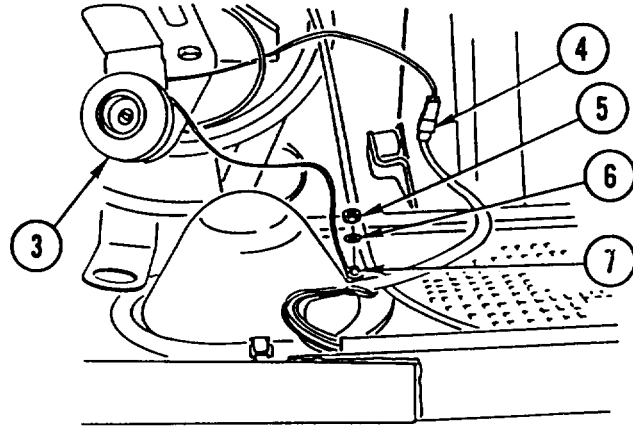

5. REMOVE BLOCKER (8) from tubing (9) and bottom of switch (3).
6. REMOVE four bolts (10), four washers (11), four lock nuts (12), retaining strap (13), seal (14), SWITCH (3), and bracket (15). DISCARD lock NUTS and SEAL.

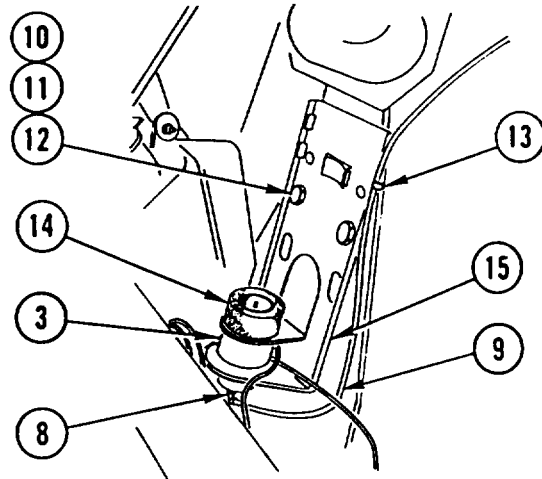

INSTALLATION

1. INSTALL SWITCH (1) and new seal (2) on bracket (3).
2. INSTALL BRACKET (3), four bolts (4), four washers (5), and four new lock nuts (6).
3. INSTALL BLOCKER (7) in switch (1).
4. CONNECT TUBING (8) to blocker (7).
5. INSTALL TUBING (8) on bracket (3) and INSTALL retaining STRAP (9).

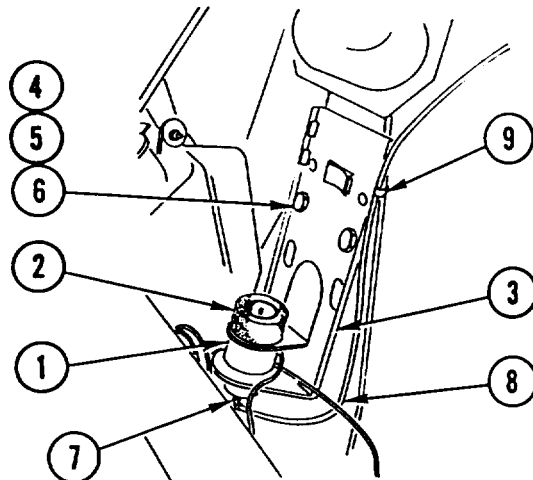

COLD START AID REPLACEMENT (CONT)

6. INSTALL ground WIRE (10), new lock washer (11), and nut (12).
7. CONNECT SWITCH (1) from engine temperature sender at terminal (13).

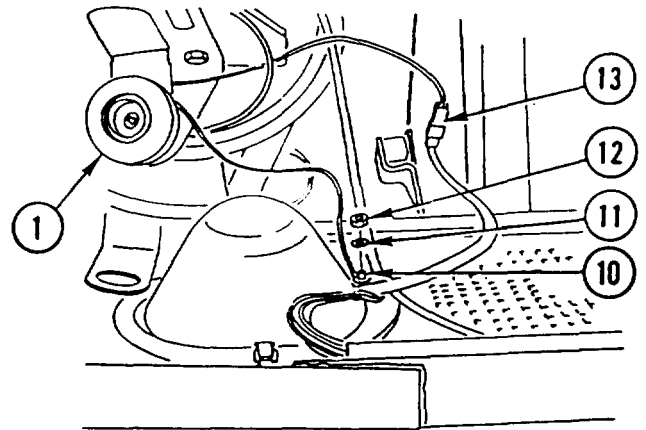

CAUTION
 During installation of cartridge,
 protect threaded area from
 damage.

8. INSTALL CARTRIDGE (14) and clamp (15).
 TIGHTEN CLAMP to 45 in.-lb (51 N.cm).

NOTE

Follow-on Maintenance:
 Install outside engine hood (page
 4-388).

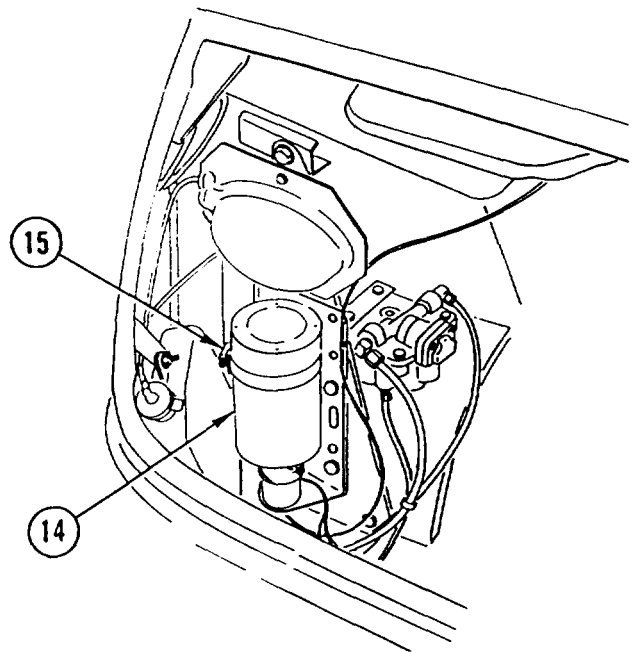

ACCELERATOR PEDAL AND LINKAGE REPLACEMENT

This task covers: a. Removal b. Installation

INITIAL SETUP

Tools and Special Equipment:

Shop Equipment, SC 4910-95-CL-A74
 Tool Kit, SC 5180-90-CL-N26

Equipment Condition:

Reference	Condition Description
Page 4-70	Hand Throttle Removed

Materials/Parts:

Pin, Cotter
 Pin, Cotter (2)

REMOVAL

1. REMOVE nut (1), washer (2), accelerator PEDAL (3), and sleeve bushing (4) from control lever (5).

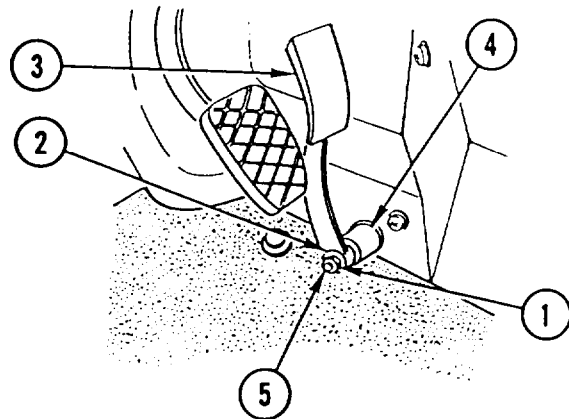

2. TILT CAB (6) (page 4-418).
3. DISCONNECT SPRING (7) from cab (6).
4. REMOVE control LEVER (5) from cab (6).

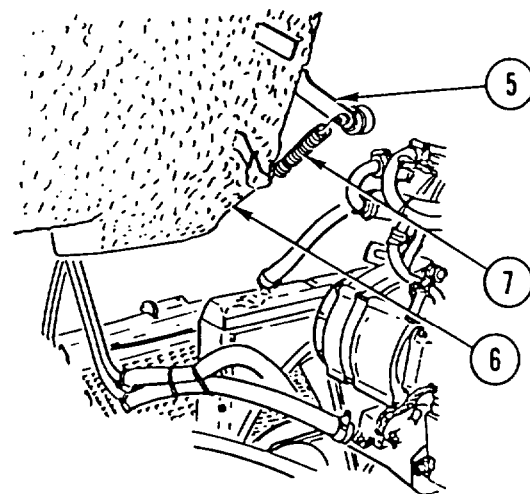

ACCELERATOR PEDAL AND LINKAGE REPLACEMENT (CONT)

5. REMOVE sleeve bushing (8), two washers (9), and SPRING (7) from control lever(5).
6. REMOVE nut (10), bolt (11), washer (12), ROLLER (13), and spacer (14) from control lever (5).

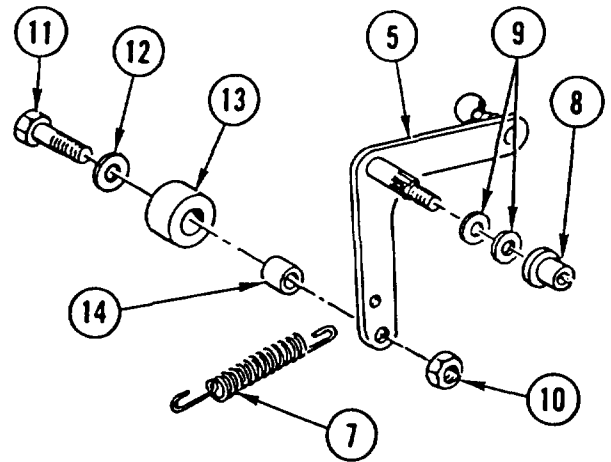

7. REMOVE cotter pin (15), washer (16), and control LEVER (17) from lever bracket (18). DISCARD rotter PIN.
8. REMOVE cotter pin (19), washer (20), and CLEVIS (21) from control lever (17). DISCARD cotter PIN.
9. REMOVE retaining ring (22), washer (23), and control LEVER (17) from bracket (24).

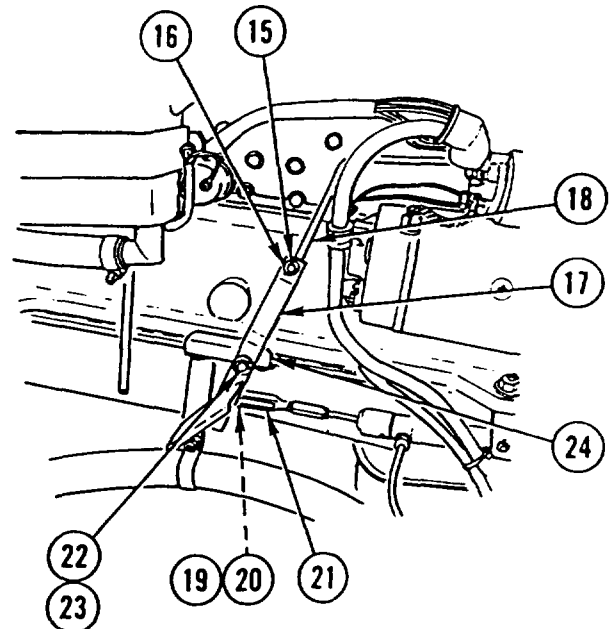

ACCELERATOR PEDAL AND LINKAGE REPLACEMENT (CONT)

10. REMOVE cotter pin (25), washer (26), and lever BRACKET (18) from control lever (27). DISCARD cotter PIN.

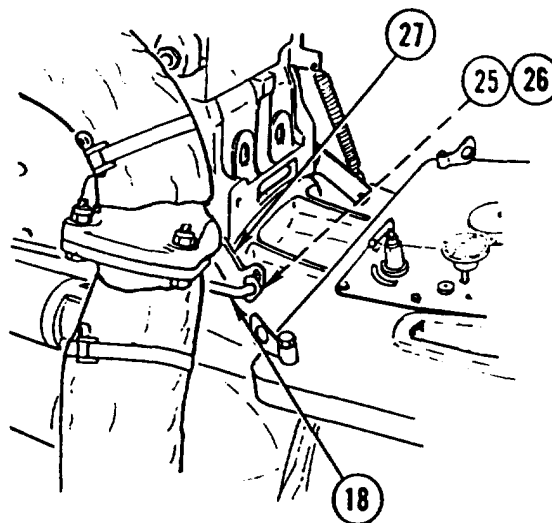

11. REMOVE two screws (28), two washers (29), and BRACKET (24) from engine oil pan flange (30).
12. RE-INSTALL two washers (29) and two screws (28).

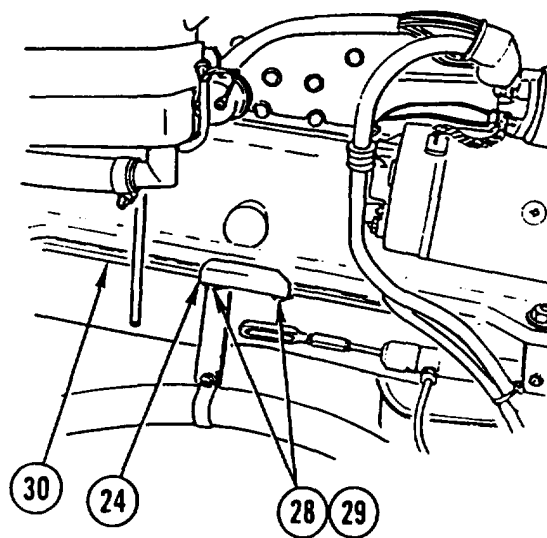

ACCELERATOR PEDAL AND LINKAGE REPLACEMENT (CONT)

INSTALLATION

1. REMOVE two screws (1) and two washers (2).
2. INSTALL BRACKET (3), two washers (2), and two screws (1) on engine oil pan flange (4).

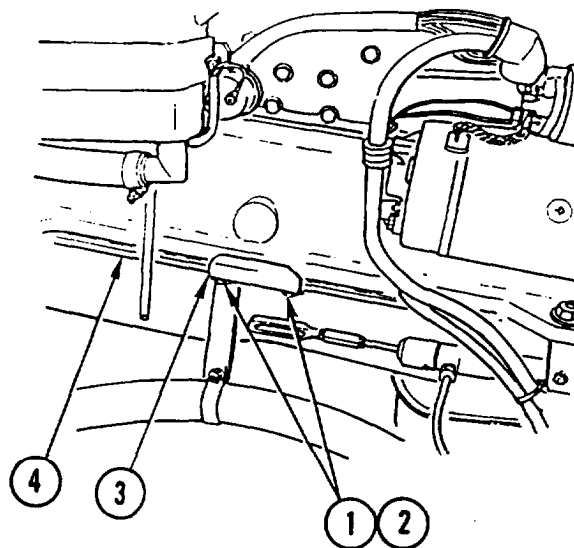

3. INSTALL lever BRACKET (5), washer (6), and new cotter pin (7) on control lever (8).

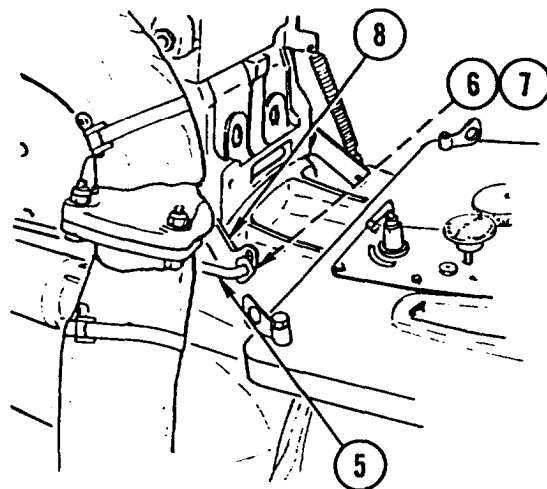

ACCELERATOR PEDAL AND LINKAGE REPLACEMENT (CONT)

4. INSTALL control LEVER (9), washer (10), and retaining ring (11) on bracket (3).
5. INSTALL CLEW (12), washer (13), and new cotter pin (14) on control lever (9).
6. INSTALL control LEVER (9), washer (15), and new cotter pin (16) on lever bracket (5).

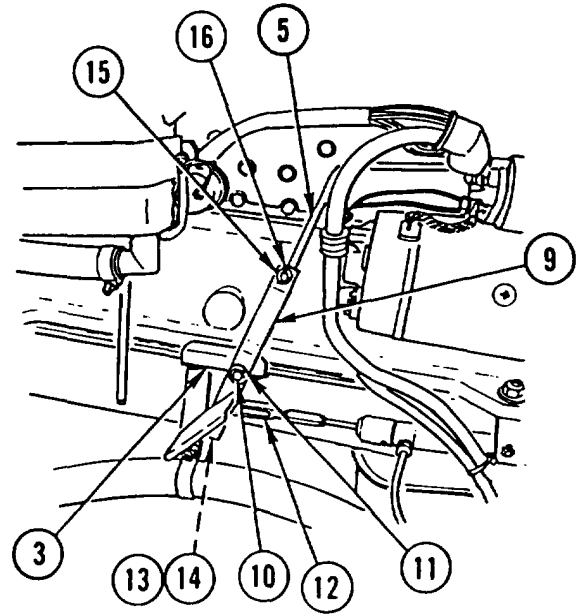

7. INSTALL spacer (17), ROLLER (18), washer (19), bolt (20), and nut (21) on control lever (22).
8. INSTALL SPRING (23), two washers (24), and sleeve bushing (25) on control lever (22).

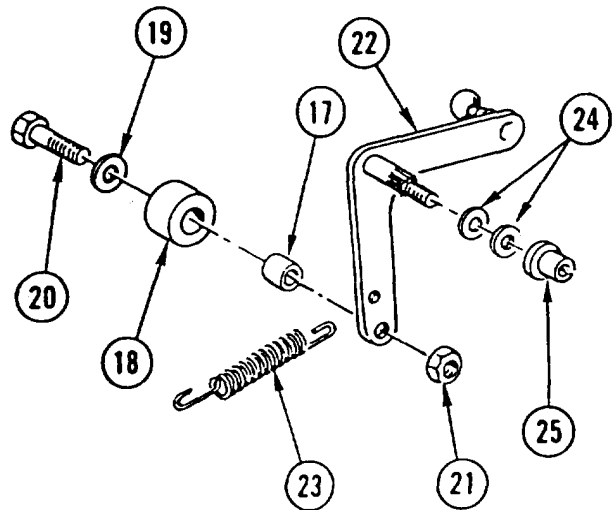

ACCELERATOR PEDAL AND LINKAGE REPLACEMENT (CONT)

9. INSTALL control LEVER (22) in cab (26).
10. CONNECT SPRING (23) to cab (26).
11. LOWER CAB (26) (page 4-418).

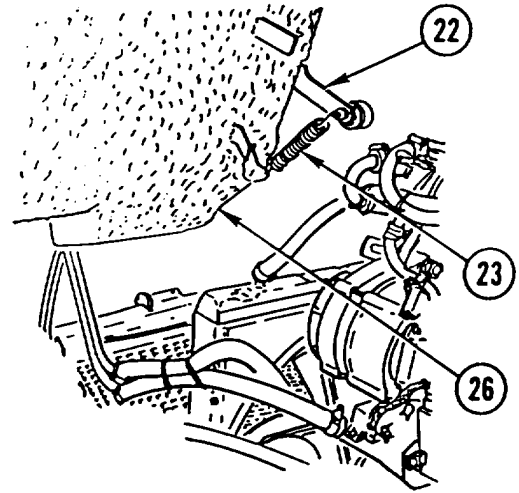

12. INSTALL sleeve bushing (27), accelerator PEDAL (28), washer (29), and nut (30) on control lever (22).

NOTE

Follow-on Maintenance:
Install hand throttle (page 4-70).

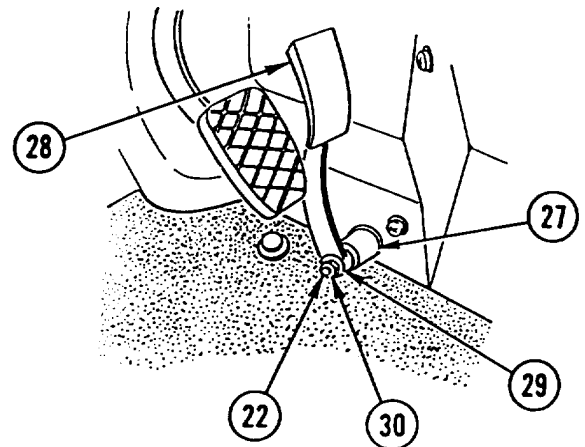

ACCELERATOR LINKAGE REPLACEMENT

This task covers: a. Removal b. Installation

INITIAL SETUP

Tools and Special Equipment:

Tool Kit, SC 5180-90-CL-N26

Materials/Parts:

Pin, Cotter

Washer, Spring
Tension

Equipment Condition:

Reference

Page 4-418

Page 4-81

Condition Description

Cab Tilted

Muffler Pipes and Clamps
Removed

REMOVAL

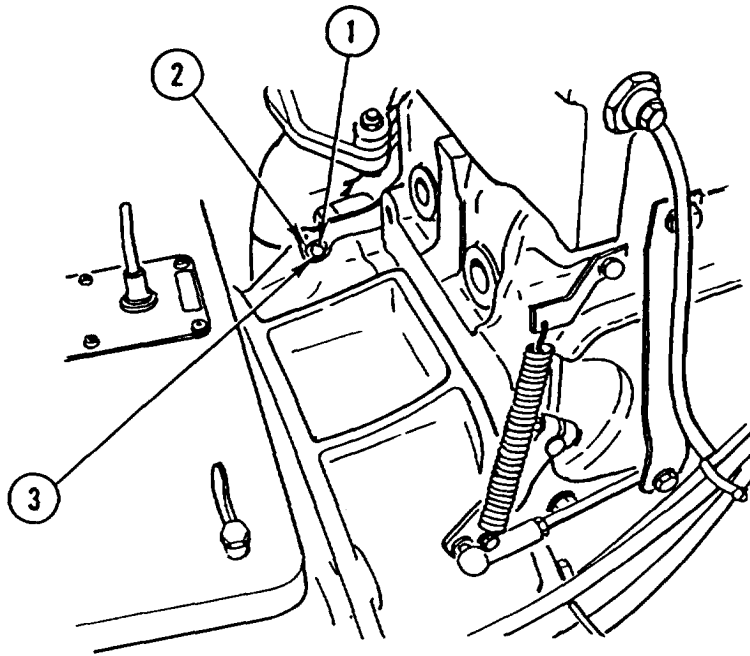

1. REMOVE cotter PIN (1) and washer (2) and DISCONNECT ROD (3). DISCARD cotter PIN.

ACCELERATOR LINKAGE REPLACEMENT (CONT)

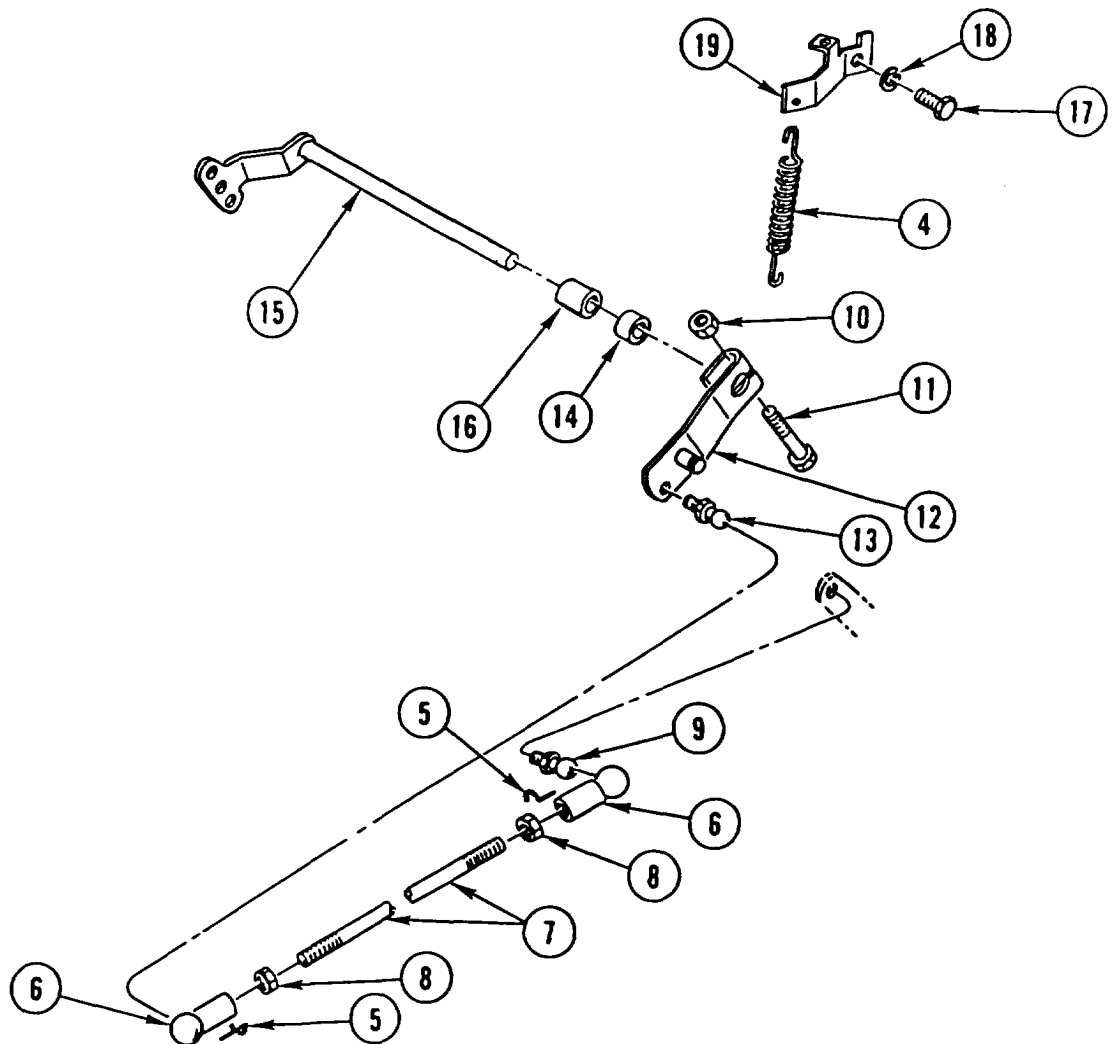

2. DISCONNECT SPRING (4).
3. REMOVE two CLIPS (5)
4. DISCONNECT two ball SOCKETS (6) and REMOVE connecting LINK (7).
5. REMOVE two ball SOCKETS (6) and two nuts (8) from connecting link (7).
6. REMOVE pivot BALL (9).
7. REMOVE nut (10), bolt (11), and LEVER (12).
8. REMOVE ball STUD (13) from lever (12).
9. REMOVE spacer (14), SHAFT (15), and spacer (16).
10. REMOVE screw (17), spring tension washer (18), and BRACKET (19). DISCARD spring tension WASHER.

ACCELERATOR LINKAGE REPLACEMENT (CONT)

INSTALLATION

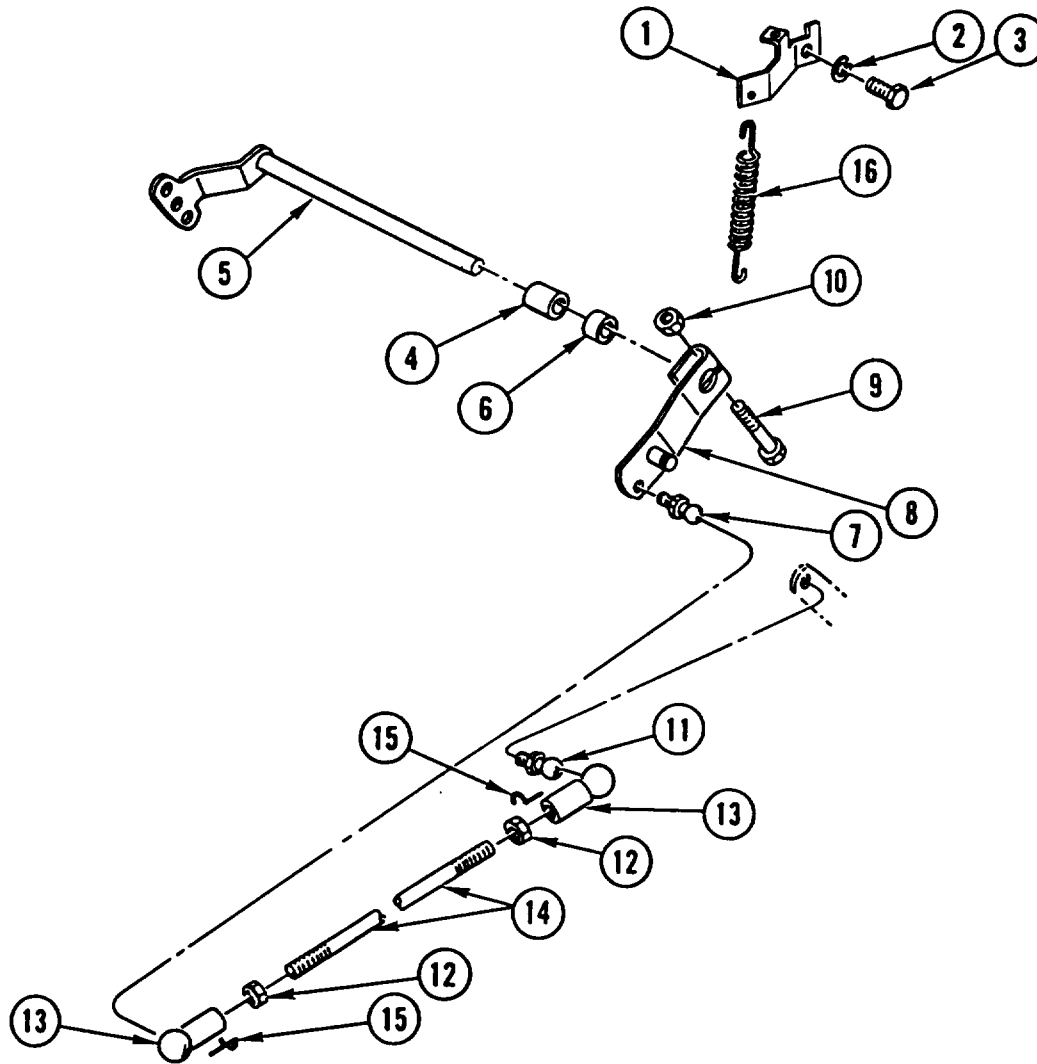

1. INSTALL BRACKET (1), new spring tension washer (2), and screw (3).
2. INSTALL spacer (4), SHAFT (5), and spacer (6).
3. INSTALL ball STUD (7) in lever (8).
4. INSTALL LEVER (8), bolt (9), and nut (10).

ACCELERATOR LINKAGE REPLACEMENT (CONT)

5. INSTALL pivot BALL (11).
6. INSTALL two nuts (12) and two ball SOCKETS (13) in connecting link (14).
7. INSTALL connecting LINK (14) and CONNECT two ball SOCKETS (13).
8. INSTALL two CLIPS (15).
9. CONNECT SPRING (16).

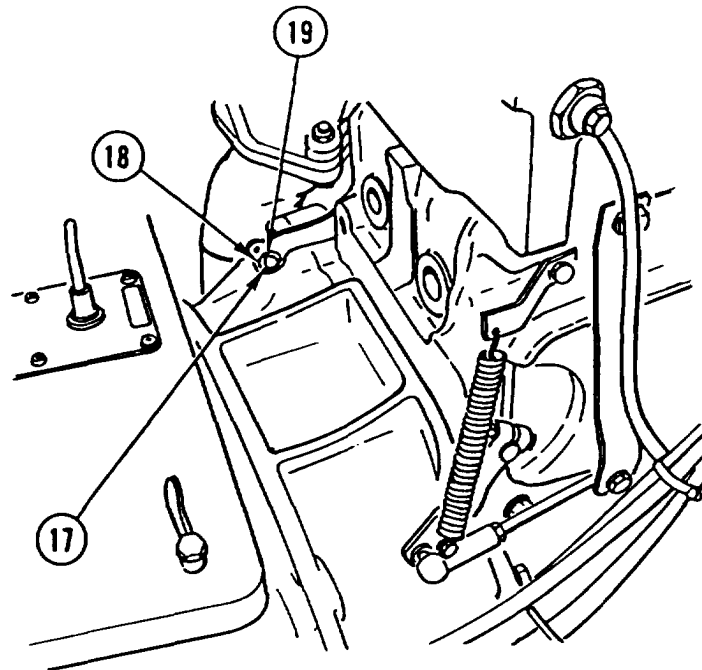

10. CONNECT ROD (17) and INSTALL washer (18), and new cotter PIN (19).

NOTE

Follow-on Maintenance:

- Install muffler pipes and clamps (page 4-81).
- Lower cab (page 4-418).
- Adjust accelerator linkage (page 4-68).

ACCELERATOR LINKAGE ADJUSTMENT

This task covers: Adjustment

INITIAL SETUP

Tools and Special Equipment:

Tool Kit, SC 5180-90-CL-N26

Equipment Condition:

Reference

Page 4-389

Condition Description

Inside Engine Hood
Removed

ADJUSTMENT

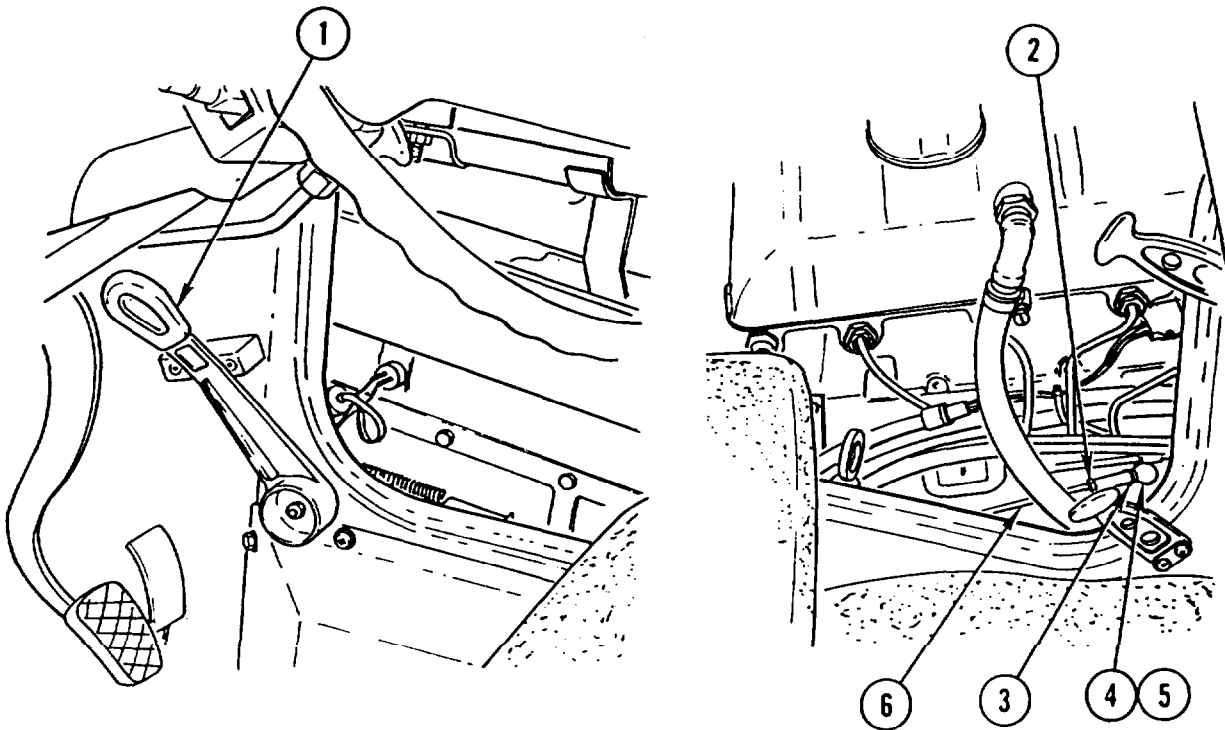

1. With engine idling, push hand throttle (1) all the way forward to its stop.
2. If engine continues to run, adjust accelerator linkage using following procedure:
 - a. Loosen nut (2).
 - b. Remove clip (3).
 - c. Disconnect ball socket (4) from pivot ball (5).
 - d. Turn ball socket (4) counterclockwise to shorten connecting link (6).
 - e. Connect ball socket (4) to pivot ball (5)

ACCELERATOR LINKAGE ADJUSTMENT (CONT)

- f. Install clip (3).
 - g. Tighten nut (2).
 - h. Repeat step 1. If engine continues to run, repeat step 2 until engine stops running when hand throttle (1) reaches its stop.
3. If engine stops running before hand throttle (1) reaches its stop, adjust accelerator linkage using following procedure:
- a. Loosen nut (2).
 - b. Remove clip (3).
 - c. Disconnect ball socket (4) from pivot ball (5).
 - d. Turn ball socket (4) clockwise to lengthen connecting link (6).
 - e. Connect ball socket (4) to pivot ball (5).
 - f. Install clip (3).
 - g. Tighten nut (2).
 - h. Repeat step 1. If engine stops running before hand throttle (1) reaches its stop, repeat step 3 until engine stops running when hand throttle (1) reaches its stop.

NOTE

Follow-on Maintenance:

Install inside engine hood (page 4-389).

HAND THROTTLE REPLACEMENT

This task covers: a. Removal b. Installation

INITIAL SETUP

Tools and Special Equipment:

Tool Kit, SC 5180-90-CL-N26

Materials/Parts:

Packing

Nut, Lock

Equipment Condition:

Reference

Page 4-389

Condition Description

Inside Engine Hood
Removed

REMOVAL

1. REMOVE nut (1), washer (2), packing (3), LEVER (4), and washer (5). DISCARD PACKING.

2. REMOVE SPRING (6).

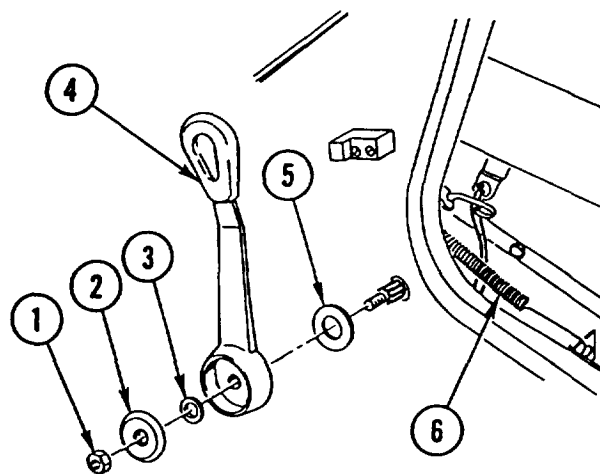

3. REMOVE LEVER (7) from bulkhead.

4. REMOVE SPACER (8) from lever (7).

5. REMOVE bail STUD (9) from ball stud (10).

6. REMOVE lock nut (11), bushing (12), LEVER (7), and pin (13) from ball stud (9). DISCARD lock NUT.

7. REMOVE NUT (14) from pin (13).

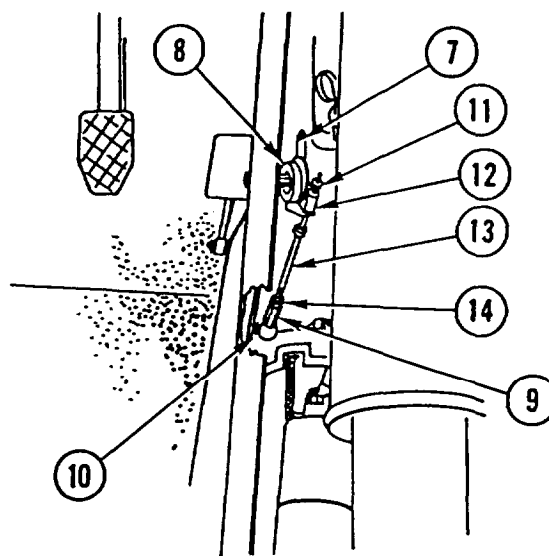

HAND THROTTLE REPLACEMENT (CONT)

INSTALLATION

1. INSTALL NUT (14) on pin (13).
2. INSTALL pin (13), LEVER (7), bushing (12), and new lock nut (11) on ball stud (9).
3. INSTALL ball STUD (9) in ball stud (10).
4. INSTALL SPACER (8) on lever (7).
5. INSTALL LEVER (7) through bulkhead.

NOTE

- Pin (13) must be in down position prior to performing step 6.
- Lever (4) must be installed in shutoff position.

6. INSTALL washer (5), LEVER (4), new packing (3), washer (2), and nut (1) on pin (13).
7. INSTALL SPRING (6).

NOTE

Follow-on Maintenance:
Install inside engine hood (page 4-389).

AIR CYLINDER REPLACEMENT

This task covers: a. Removal b. Installation

INITIAL SETUP

Applicable Configuration:

SEE

Tools and Special Equipment:

Shop Equipment, SC 4910-95-CL-A74
 Tool Kit, SC 5180-90-CL-N26

Materials/Parts:

Pin, Cotter (2)

Nut, Lock

Equipment Condition:

Reference

Page 2-23

Condition Description

Air Pressure Relieved

General Safety Instructions:

WARNING

Do not disconnect any air system lines or fittings unless vehicle engine is shut off and air system pressure is relieved. To do so could result in injury to personnel.

REMOVAL

1. DISCONNECT air LINE (1) from cylinder (2).
2. REMOVE cotter pin (3) and PIN (4). DISCARD cotter PIN.
3. REMOVE cotter pin (5), washer (6), air CYLINDER (2), and washer (7). DISCARD cotter PIN.
4. REMOVE ADAPTER (8).
5. LOOSEN NUT (9).
6. REMOVE connecting LINK (10), adjusting nut (11), and lock nut (12). DISCARD lock NUT.

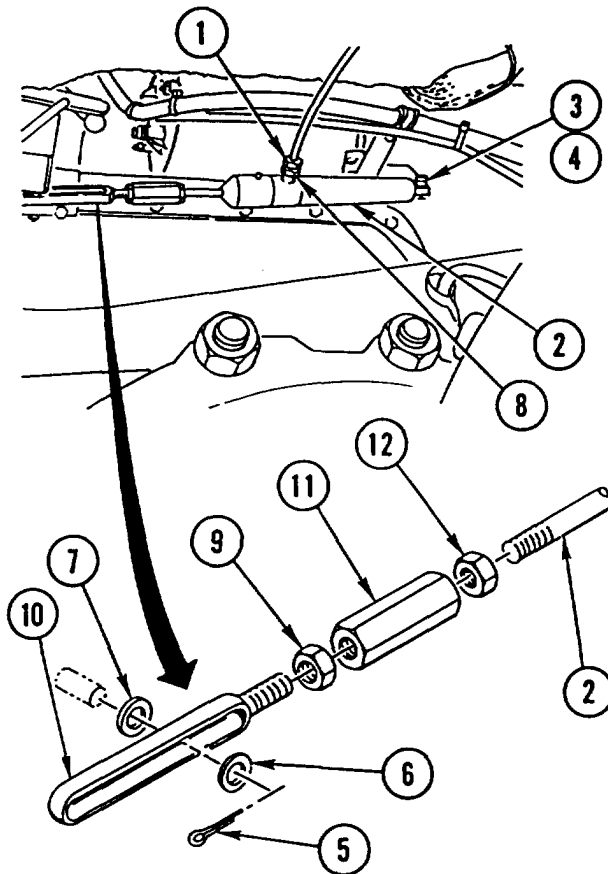

AIR CYLINDER REPLACEMENT (CONT)

INSTALLATION

1. INSTALL connecting LINK (10), adjusting nut (11), and new lock nut (12).
2. TIGHTEN NUT (9).
3. INSTALL ADAPTER (8).
4. INSTALL air CYLINDER (2), washer (7), washer (6), and new cotter pin (5).
5. INSTALL PIN (4) and new cotter pin (3).
6. CONNECT air LINE (1) to cylinder (2).

NOTE

Follow-on Maintenance:

Adjust air cylinder (page 4-76).

AIR CYLINDER REPLACEMENT

This task covers: a. Removal b. Installation

INITIAL SETUP

Applicable Configuration:

HMMH

Tools and Special Equipment:

Shop Equipment, SC 4910-95-CL-A74
Tool Kit, SC 5180-90-CL-N26

Materials/Parts:

Pin, Cotter (2)

Equipment Condition:

Reference

Page 2-23

Condition Description:

Air Pressure Relieved

General Safety Instructions:

WARNING

Do not disconnect any air system lines or fittings unless vehicle engine is shut off and air system pressure is relieved. To do so could result in injury to personnel.

REMOVAL

NOTE

Tag lines prior to disconnecting to aid in connecting.

1. DISCONNECT two air LINES (1 and 2) from cylinder (3).
2. REMOVE cotter pin (4) and PIN (5) from bracket (6). DISCARD cotter PIN.
3. REMOVE cotter pin (7), washer (8), CYLINDER (3), and washer (9). DISCARD cotter PIN.
4. REMOVE two ADAPTERS (10 and 11) from cylinder (3).
5. MEASURE and RECORD DISTANCE between connecting link end of cylinder (3) and end of connecting link (12).
6. LOOSEN NUT (13). REMOVE connecting LINK (12) and adjusting nut (14) from cylinder (3).
7. MEASURE and RECORD DISTANCE between rod end of cylinder (3) and end of rod end clevis (15).
8. LOOSEN NUT (16). REMOVE rod end CLEVIS (15) from cylinder (3).

AIR CYLINDER REPLACEMENT (CONT)

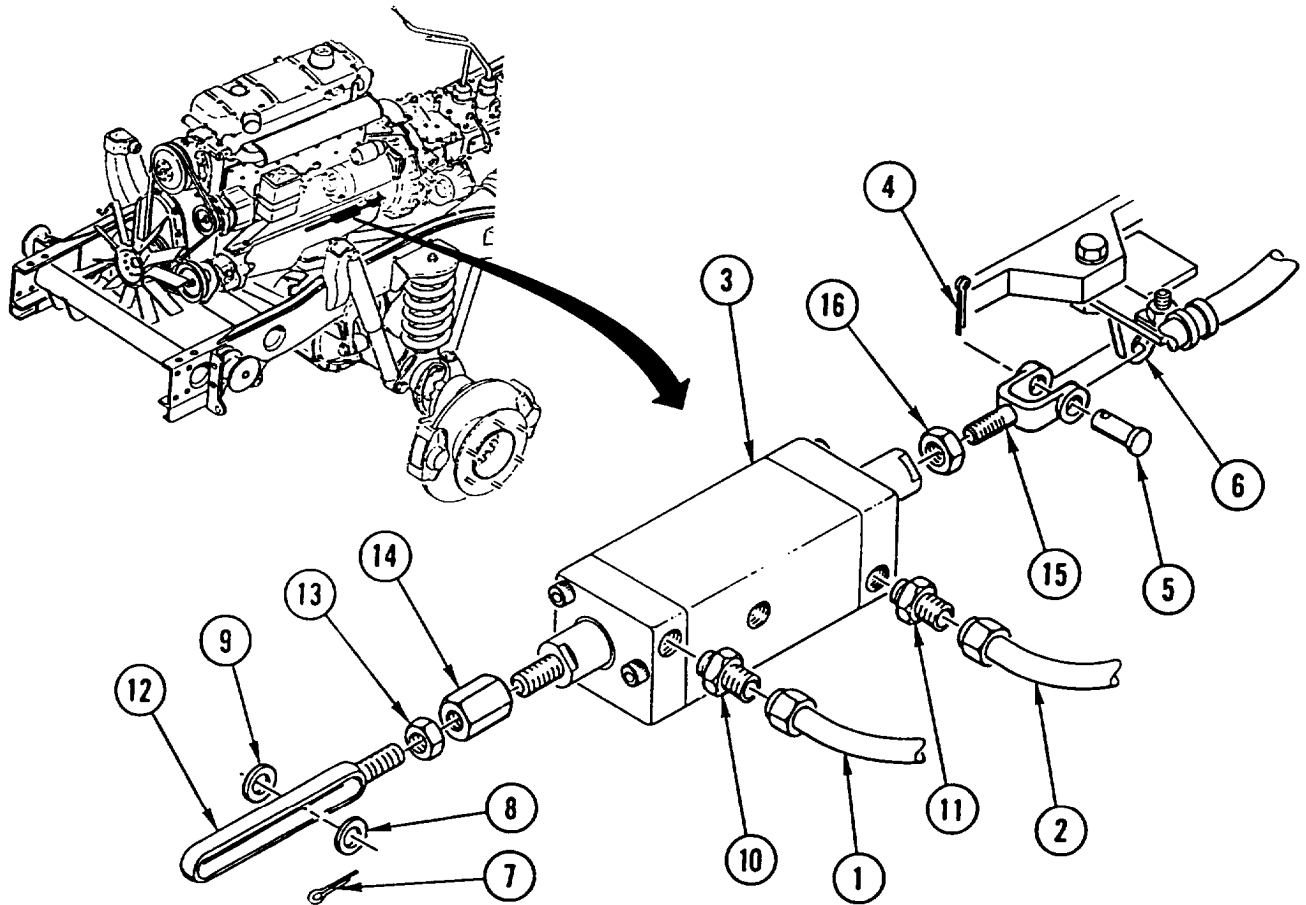

INSTALLATION

1. INSTALL rod end CLEVIS (15) in cylinder (3) until distance between rod end of cylinder (3) and end of rod end clevis (15), NOTED during REMOVAL, is attained. TIGHTEN NUT (16).
2. INSTALL adjusting nut (14) and connecting LINK (12) on cylinder (3) until distance between connecting link end of cylinder (3) and end of connecting link (12), NOTED during REMOVAL, is attained. DO NOT TIGHTEN NUT (13).
3. INSTALL two ADAPTERS (10 and 11) in cylinder (3).
4. INSTALL washer (9), CYLINDER (3), washer (8), and new cotter pin (7).
5. INSTALL rod end CLEVIS (15), pin (5), and new cotter pin (4) on bracket (6).
6. CONNECT two air LINES (1 and 2) to cylinder (3).

NOTE

Follow-on Maintenance:

Adjust air cylinder (page 4-77).

AIR CYLINDER ADJUSTMENT

This task covers: Adjustment

INITIAL SETUP

Applicable Configuration:

SEE

Tools and Special Equipment:

Shop Equipment, SC 4910-95-CL-A74
Tool Kit, SC 5180-90-CL-N26

Equipment Condition:

Reference	Condition Description
Page 2-22	Vehicle Blocked

General Safety Instructions:

WARNING

Make sure parking brake is set and that wheels are blocked. Failure to do so could result in injury to personnel.

ADJUSTMENT

1. Set parking brake.
2. Loosen two lock nuts (1 and 2).
3. Start engine and set engine idle at 700-750 rpm.
4. Activate hydraulic tools switch.
5. Check tachometer to see if engine has reached 2000 rpm.
6. Turn adjusting nut (3), as required, until tachometer reads 2000 rpm.
7. Tighten two lock nuts (1 and 2) after adjustment is reached.

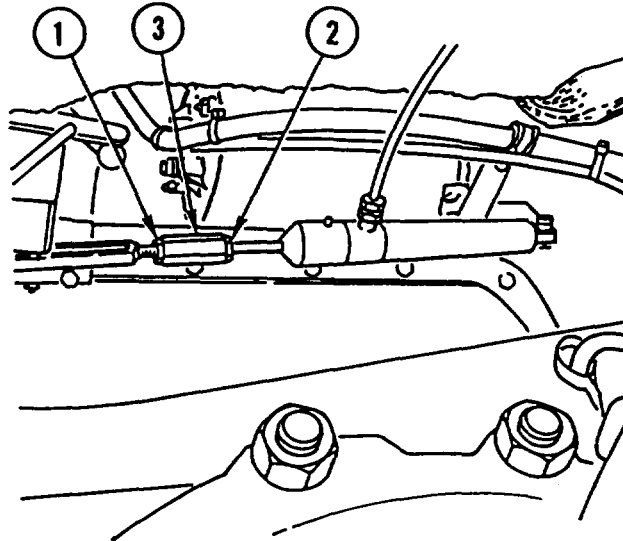

AIR CYLINDER ADJUSTMENT

This task covers: Adjustment

INITIAL SETUP

Applicable Configuration:

HMMH

Tools and Special Equipment:

Shop Equipment, SC 4910-95-CL-A74
 Tool Kit, SC 5180-90-CL-N26

Equipment Condition:

Reference	Condition Description
Page 2-22	Vehicle Blocked

General Safety Instructions:

WARNING

Make sure parking brake is set and that wheels not being lifted are blocked. Failure to do so could result in serious injury to personnel.

ADJUSTMENT

1. Start engine and set engine idle speed at 700-750 rpm.
2. Engage hydraulic tools switch (1) and check vehicle tachometer. Engine rpm should be 2000 rpm.

NOTE

Perform steps 3 thru 5 only if engine speed is not 2000 rpm. If engine speed is 2000 rpm, go to step 6.

3. Disengage hydraulic tools switch (1).

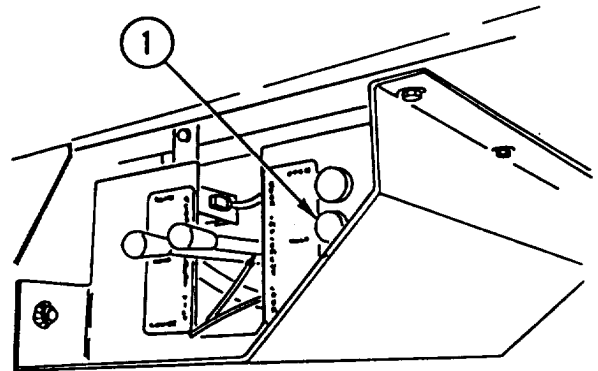

AIR CYLINDER ADJUSTMENT (CONT)

NOTE

Turn adjusting nut toward passenger side of vehicle to increase engine rpm, or toward driver side to decrease engine rpm.

4. Turn adjusting nut (2) approximately 1/4-1/2 turn to increase or decrease engine rpm as needed.
5. Repeat steps 2 thru 4 until 2000 rpm is achieved.
6. Tighten nut (3).
7. Engage crane engine idle switch (4) and check vehicle tachometer. Engine rpm should be 1100 rpm.

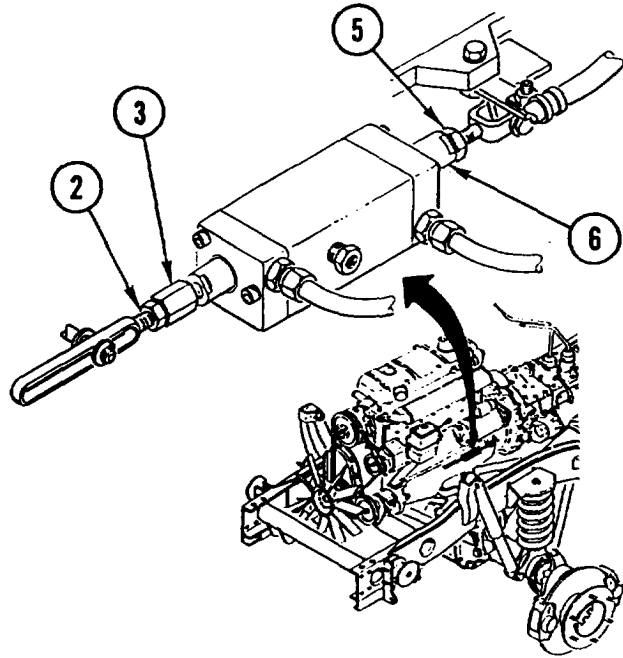

NOTE

Perform steps 8 thru 10 only if engine speed is not 1100 rpm.

8. Disengage crane engine idle switch (4).

NOTE

Turn cylinder plunger toward driver side of vehicle to increase engine rpm, or toward passenger side to decrease engine rpm.

9. Loosen nut (5) and turn cylinder plunger (6) approximately 1/4-1/2 turn to increase or decrease engine rpm as needed.
10. Tighten nut (5).
11. Repeat step 2. If engine rpm is not correct, repeat steps 3 thru 10.

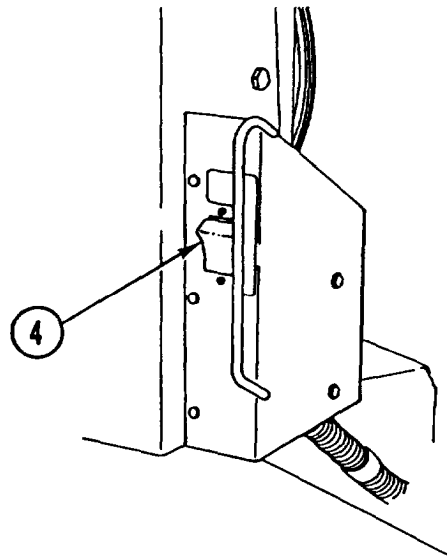

Section IV. EXHAUST SYSTEM MAINTENANCE

OVERVIEW

This section illustrates and describes procedures for maintenance of the exhaust system and related parts. A list of tasks contained in this section is shown below.

	Page
Muffler Replacement	4-80
Muffler Pipes and Clamps Replacement	4-81
Exhaust Manifold Screening Plate Replacement	4-85

MUFFLER REPLACEMENT

This task covers: a. Removal b. Installation

INITIAL SETUP

Tools and Special Equipment:

Shop Equipment, SC 4910-95-CL-A74
Tool Kit, SC 5180-90-CL-N26

Materials/Parts:

Washer, Spring
Tension (6)

General Safety Instructions:

WARNING
BURN HAZARD

Allow engine to cool before performing maintenance on the muffler, exhaust pipe, or exhaust manifold. If necessary, use insulated pads and gloves.

REMOVAL

1. LOOSEN NUT (1) and SLIDE CLAMP (2) forward on exhaust pipe (3).
2. LOOSEN two NUTS (4) and SLIDE CLAMP (5) forward on exhaust pipe (6).
3. REMOVE two nuts (7), two SCREWS (8), and six spring tension washers (9) from two clamps (10). DISCARD spring tension WASHERS.
4. REMOVE MUFFLER (11) from exhaust pipes (3 and 6).

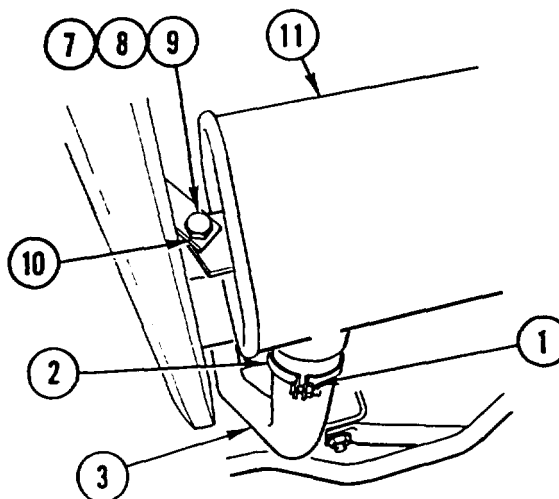

INSTALLATION

1. INSTALL MUFFLER (11) on exhaust pipes (3 and 6).
2. INSTALL two SCREWS (8), six new spring tension washers (9), and two nuts (7) on two clamps (10).
3. INSTALL CLAMP (5) on muffler (11) and exhaust pipe (6). TIGHTEN two NUTS (4).
4. INSTALL CLAMP (2) on muffler (11) and exhaust pipe (3). TIGHTEN NUT (1).

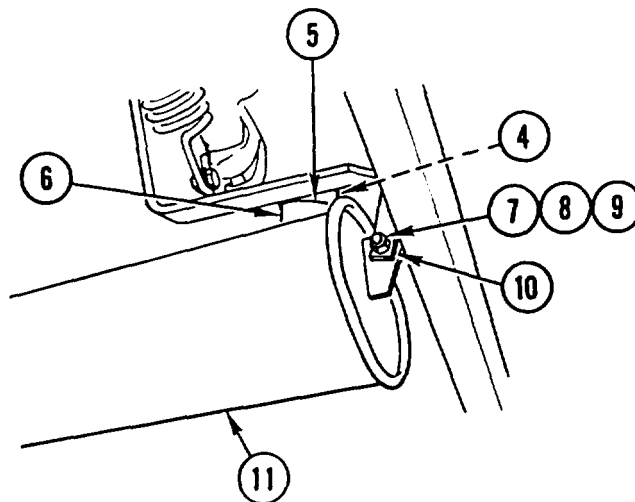

MUFFLER PIPES AND CLAMPS REPLACEMENT

This task covers: a. Removal b. Installation

INITIAL SETUP

Tools and Special Equipment:

Shop Equipment, SC 4910-95-CL-A74
 Tool Kit, SC 5180-90-CL-N26

Materials/Parts:

Gasket
 Nut, Lock (3)

Personnel Required: (2)

Equipment Condition:

Reference	Condition Description
Page 4-418	Cab Tilted

General Safety Instructions:

WARNING
BURN HAZARD

Allow engine to cool before performing maintenance on the muffler, exhaust pipe, or exhaust manifold. If necessary, use insulated pads and gloves.

REMOVAL

1. LOOSEN two NUTS (1) and SLIDE CLAMP (2) toward muffler (3).

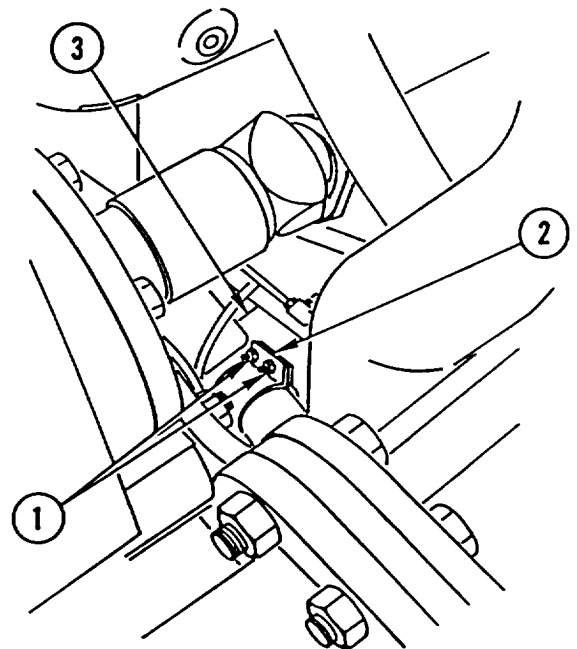

MUFFLER PIPES AND CLAMPS REPLACEMENT (CONT)

2. REMOVE two nuts (4), clamp (5), and spark ARRESTOR (6).
3. REMOVE vertical exhaust PIPE (7).

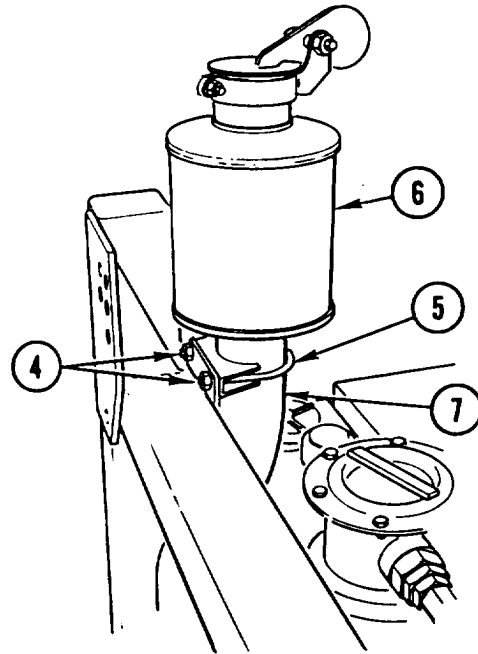

4. LOOSEN NUT (8) and SLIDE CLAMP (9) toward muffler (3).

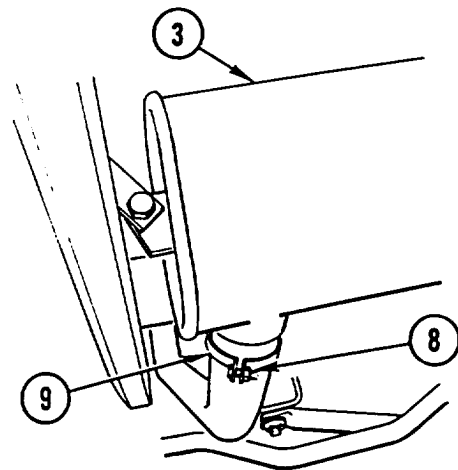

MUFFLER PIPES AND CLAMPS REPLACEMENT (CONT)

5. REMOVE three BOLTS (10), three lock nuts (11), and gasket (12). DISCARD GASKET and lock NUTS.
6. REMOVE two ties (13), two straps (14), and insulation BLANKET (15).
7. REMOVE exhaust PIPE (16).

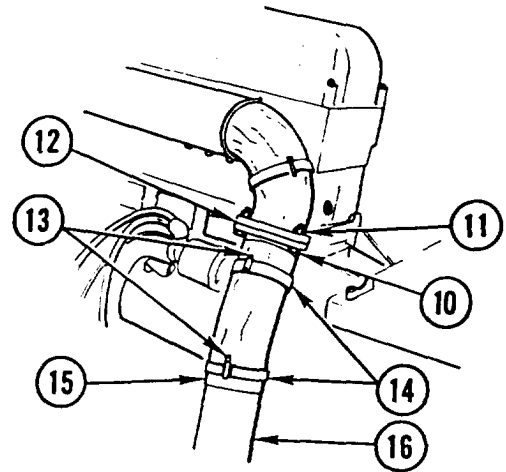

INSTALLATION

1. INSTALL vertical exhaust PIPE (1) in muffler (2).
2. SLIDE CLAMP (3) over joint and TIGHTEN two NUTS (4).

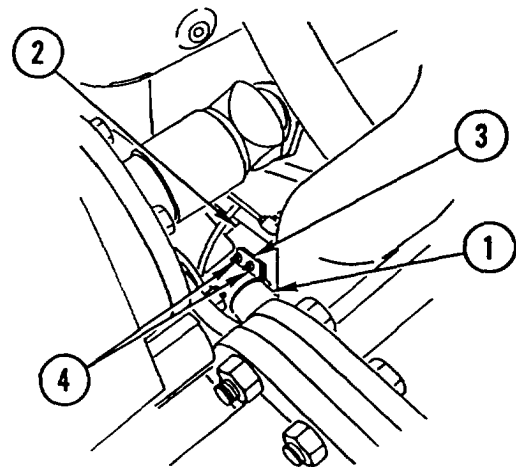

3. INSTALL spark ARRESTOR (5), clamp (6), and two nuts (7).

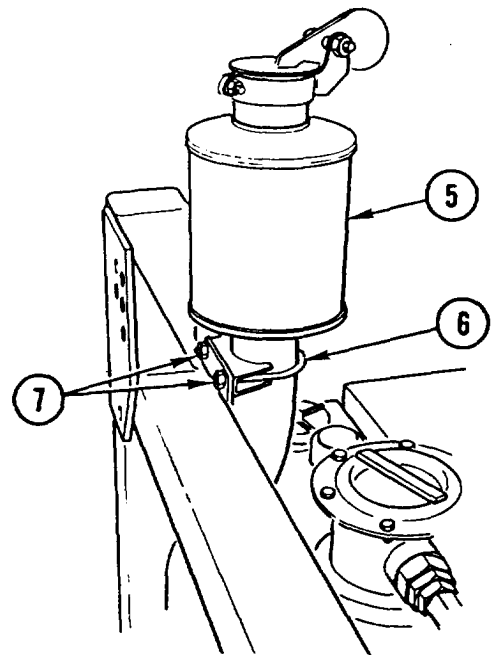

MUFFLER PIPES AND CLAMPS REPLACEMENT (CONT)

4. INSTALL exhaust PIPE (8) in muffler (2).
5. SLIDE CLAMP (9) over joint and TIGHTEN NUT (10).

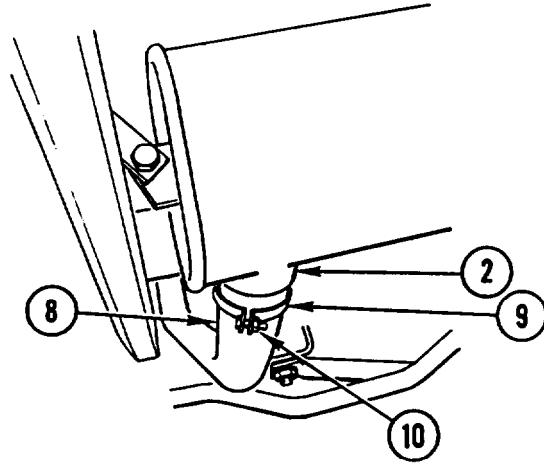

6. INSTALL new gasket (11), three BOLTS (12), and three new lock nuts (13). TIGHTEN BOLTS to 33 lb-ft (45 N•m).
7. INSTALL insulation BLANKET (14), two straps (15), and two ties (16).

NOTE

Follow-on Maintenance:
Lower cab (page 4-418).

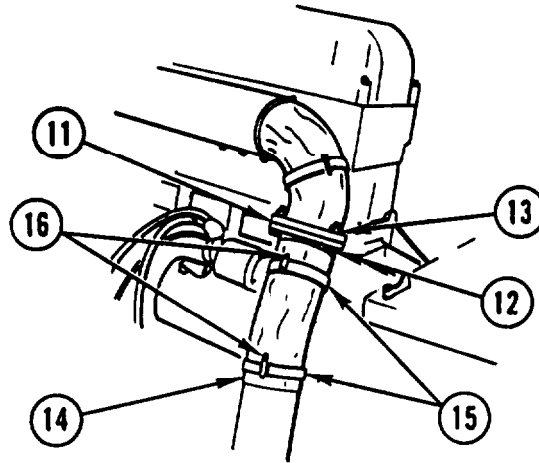

EXHAUST MANIFOLD SCREENING PLATE REPLACEMENT

This task covers: a Removal b. Installation

INITIAL SETUP

Tools and Special Equipment:

Shop Equipment, SC 4910-95-CL-A74
 Tool Kit, SC 5180-90-CL-N26

Materials/Parts:

Washer, Spring
 Tension (2)

Washer, Spring
 Tension

Equipment Condition:

Reference	Condition Description
Page 4-418	Cab Tilted

General Safety Instructions:

WARNING
BURN HAZARD

Allow engine to cool before performing maintenance on the muffler, exhaust pipe, or exhaust manifold. If necessary, use insulated pads and gloves.

REMOVAL

1. REMOVE two SCREWS (1) and two spring tension washers (2) from screening plate (3). DISCARD spring tension WASHERS.
2. REMOVE nut (4), screw (5), spring tension washer (6), spacer (7), and screening PLATE (3). DISCARD spring tension WASHER.

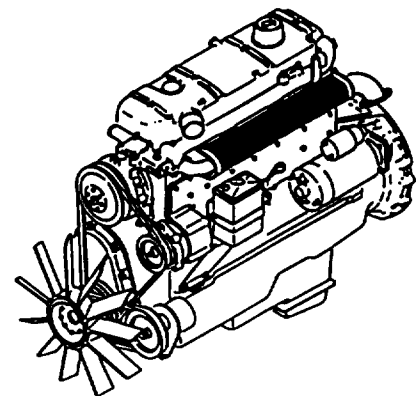

INSTALLATION

1. INSTALL screening PLATE (3), spacer (7), new spring tension washer (6), screw (5), and nut (4).
2. INSTALL two new spring tension washers (2) and two SCREWS (1).

NOTE

Follow-on Maintenance:
 Lower cab (page 4-418).

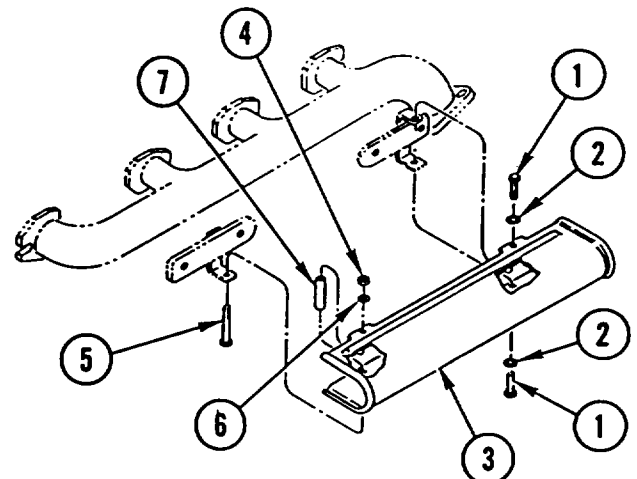

Section V. COOLING SYSTEM MAINTENANCE

OVERVIEW

This section illustrates and describes procedures for maintenance of the cooling system and related parts. A list of tasks contained in this section is shown below.

	Page
Cooling System Service.	4-87
Cooling System Test	4-89
Coolant Expansion Tank Filler Cap Pressure Test	4-90
Radiator Replacement	4-92
Coolant Expansion Tank Replacement	4-96
Coolant Expansion Tank Support Replacement	4-97
Coolant Hoses and Clamps Replacement	4-98
Coolant Thermostat Replacement.. . . .	4-100
Coolant Water Outlet Replacement.	4-101
Water Manifold and Gasket Replacement	4-102
Water Pump Replacement	4-104
Fan Impeller Replacement	4-105
Fan Belt Replacement	4-106
Fan Belt Adjustment	4-108

COOLING SYSTEM SERVICE

This task covers: a. Draining b. Filling c. Cold Weather Service

INITIAL SETUP

Tools and Special Equipment:

Shop Equipment, SC 4910-95-CL-A74
 Tool Kit, SC 5180-90-CL-N26

Materials/Parts:

Ring, Seal

References:

TM 9-207

Equipment Condition:

Reference	Condition Description
Page 4-389	Inside Engine Hood Removed

General Safety Instructions:

WARNING
BURN HAZARD

Allow engine to cool before performing maintenance on the muffler, exhaust pipe, or exhaust manifold. If necessary, use insulated pads and gloves.

DRAINING

1. Turn knob (1) on heater (2) halfway out.

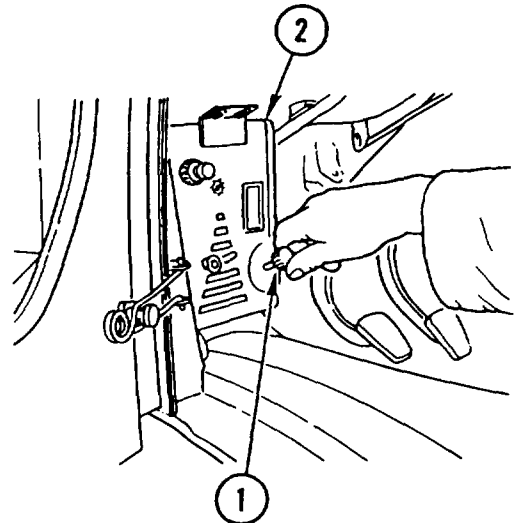

COOLING SYSTEM SERVICE (CONT)

- Remove cap (3) from expansion tank (4).

NOTE

Provide 6-gallon (23-liter) container to catch draining coolant.

- Open draincock (5) at bottom of radiator and drain coolant.
- Close draincock (5).
- Remove plug (6) and seal ring (7) and drain engine block (8). Discard seal ring.
- Install new seal ring (7) and plug (6).

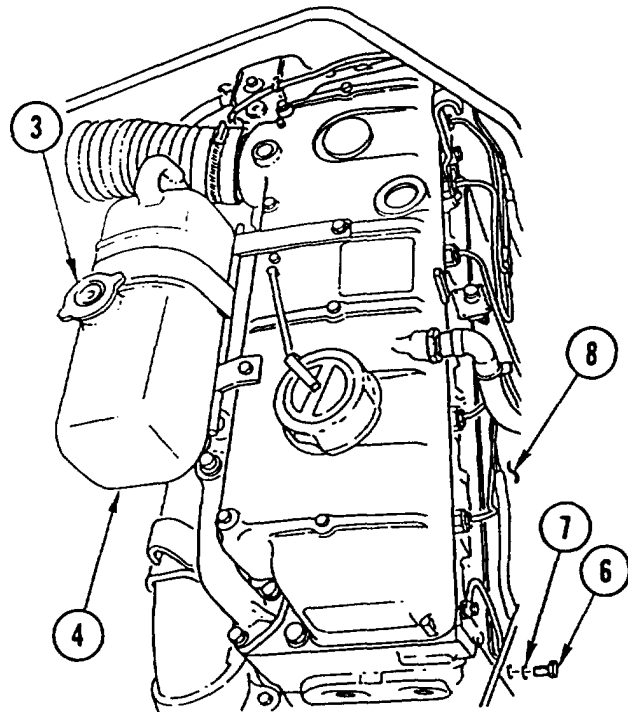

FILLING

- Make sure radiator draincock is closed and knob on heater is turned halfway out.
- Add coolant. Bring coolant level to within 1 in. (30 mm) of top edge of filler tube opening. Replace cap and tighten.
- Start and run engine for at least 5 minutes to eliminate any air pockets. Recheck coolant level; add coolant if necessary.

NOTE

Follow-on Maintenance:

Install inside engine hood (page 4-389).

COLD WEATHER SERVICE

For operation in temperatures below freezing, use recommended amount of antifreeze (page 2-14) in cooling system (TM 9-207). When proper coolant mixture is determined, fill cooling system as follows:

- Drain coolant (Draining, above).
- Flush cooling system with fresh water; close radiator draincock. Make sure all hose connections are tight.
- If water and antifreeze are added separately, pour antifreeze into radiator first, then add clean water until water level is approximately 1 in. (30 mm) below top edge of filler tube opening.
- Start and run engine at idle for 5 minutes to thoroughly mix water and antifreeze. Recheck coolant level; fill as necessary.

NOTE

Follow-on Maintenance:

Install inside engine hood (page 4-389).

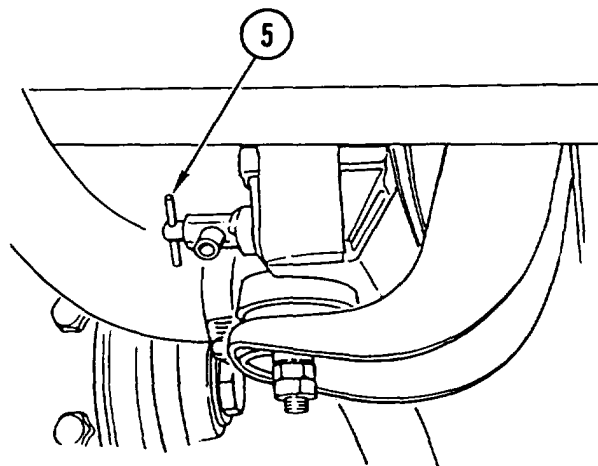

COOLING SYSTEM TEST

This task covers: Testing

INITIAL SETUP

Tools and Special Equipment:

Detector, P/N 001 589 83 21 00

Equipment Condition:

Reference	Condition Description
Page 4-389	Inside Engine Hood Removed

General Safety Instructions:

**WARNING
BURN HAZARD**

Allow engine to cool before performing maintenance on the muffler, exhaust pipe, or exhaust manifold. If necessary, use insulated pads and gloves.

TESTING

1. Turn knob (1) on heater (2) halfway out.
2. Check coolant level; fill to required limit.

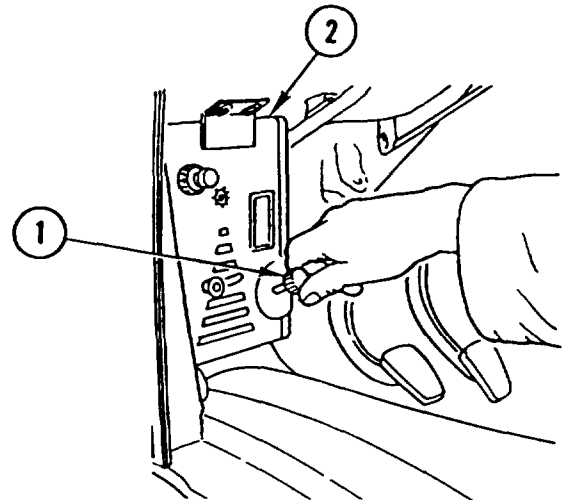

3. Remove expansion tank cap and install detector in expansion tank (3).
4. Connect air hose (4) to detector.
5. Pressurize cooling system to 14.5 psi (1 bar) and hold pressure for 5 minutes. If pressure drops, repair leak and test again.
6. Remove detector and replace expansion tank cap.

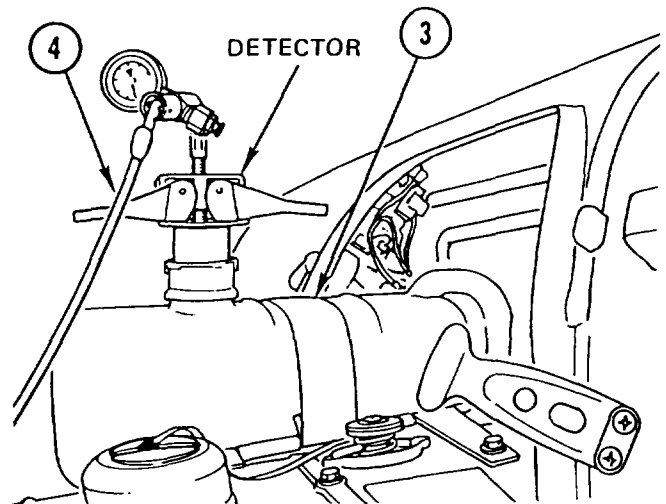

NOTE

Follow-on Maintenance:
Install inside engine hood (page 4-389).

COOLANT EXPANSION TANK FILLER CAP PRESSURE TEST

This task covers: Test

INITIAL SETUP

Tools and Special Equipment:

Adapter, Leak Check Device,
P/N 000 589 75 63 00
Detector, P/N 001 589 83 21 00

General Safety Instructions:

<p style="text-align: center;">WARNING BURN HAZARD Allow engine to cool before performing maintenance on the muffler, exhaust pipe, or exhaust manifold. If necessary, use insulated pads and gloves.</p>

Equipment Condition:

Reference	Condition Description
Page 4-389	Inside Engine Hood Removed

TEST

1. Remove filler cap (1) from coolant expansion tank (2).
2. Attach adapter to detector.
3. Install filler cap (1) on adapter.
4. Connect air hose (3) to detector.
5. Apply 14 psi (1 bar) to filler cap (1) and note opening pressure. Opening pressure should be 10 ± 1.5 psi ($0.7 \pm$ bar).
6. Remove and discard filler cap (1) if opening pressure was not 10 ± 1.5 psi (0.7 ± 1 bar).
7. Install new filler cap (1) on coolant expansion tank (2).

NOTE

Follow-on Maintenance:
Install inside engine hood (page 4-389).

COOLANT EXPANSION TANK FILLER CAP PRESSURE TEST (CONT)

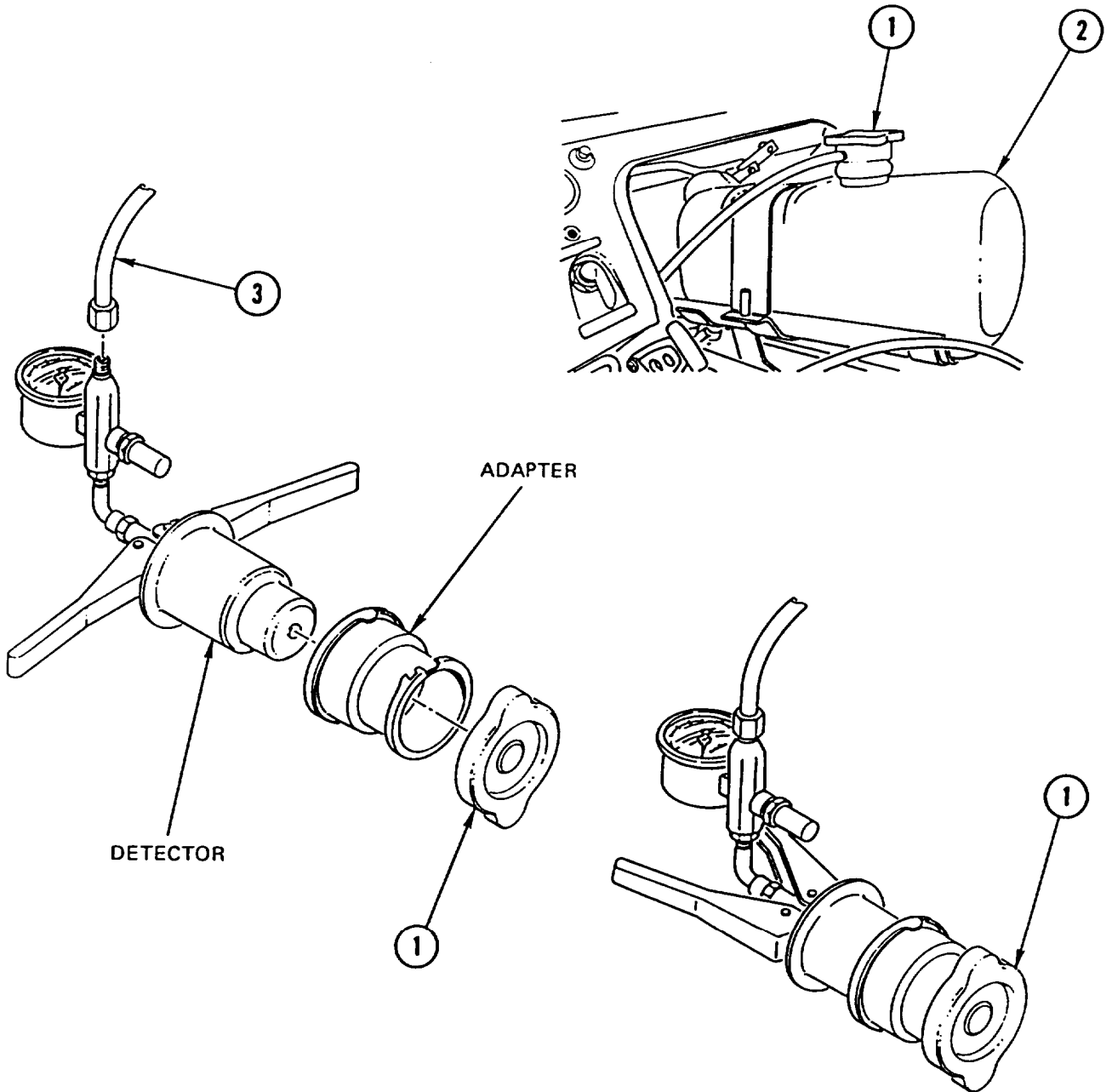

RADIATOR REPLACEMENT

This task covers: a. Removal b. Installation

INITIAL SETUP

Tools and Special Equipment:

Shop Equipment, SC 4910-95-CL-A74
Tool Kit, SC 5180-90-CL-N26

Materials/Parts:

Nut, Lock
Pin, Cotter (2)
Nut, Lock (4)
Washer, Lock (4)

Personnel Required: (2)

Equipment Condition:

Reference

Page 4-388

Page 4-87

Condition Description

Outside Engine Hood
Removed

Cooling System Drained

General Safety Instructions:

WARNING
BURN HAZARD

Allow engine to cool before performing maintenance on the muffler, exhaust pipe, or exhaust manifold. If necessary, use insulated pads and gloves.

REMOVAL

1. REMOVE DRAINCOCK (1).

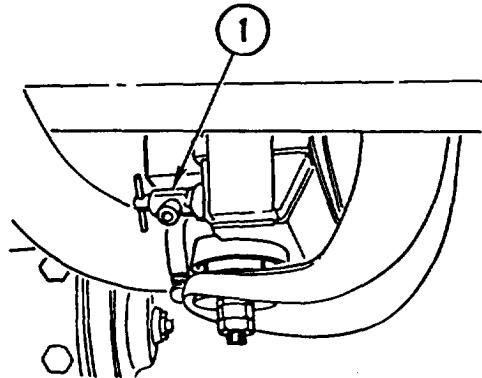

RADIATOR REPLACEMENT (CONT)

2. REMOVE two bolts (2), lock nut (3), BRACKET (4), two cotter pins (5), two clamps (6), and two bushings (7). DISCARD lock NUT and cotter PINS.

NOTE

Tag all lines prior to removal to aid in installation.

3. LOOSEN two CLAMPS (8 and 9) and REMOVE two HOSES (10 and 11).

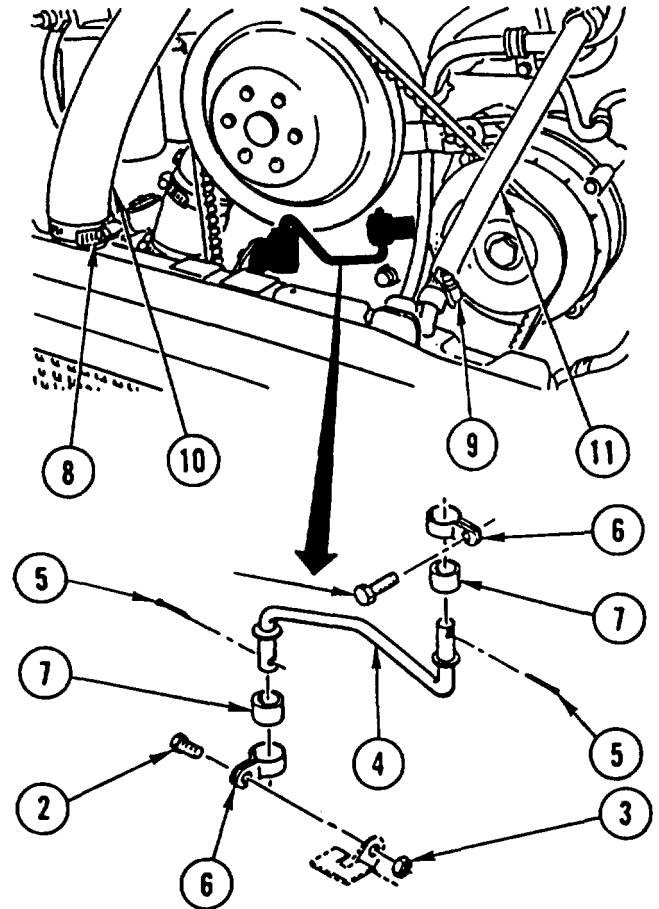

4. REMOVE two lock nuts (12), washer (13), and MOUNT (14) from both sides of radiator (15). DISCARD lock NUTS.

5. LOOSEN CLAMP (16) and DISCONNECT HOSE (17).

NOTE

Rotate fan, as necessary, to remove radiator.

6. REMOVE RADIATOR (15), two retainers (18), two mounts (19), and filler (20).

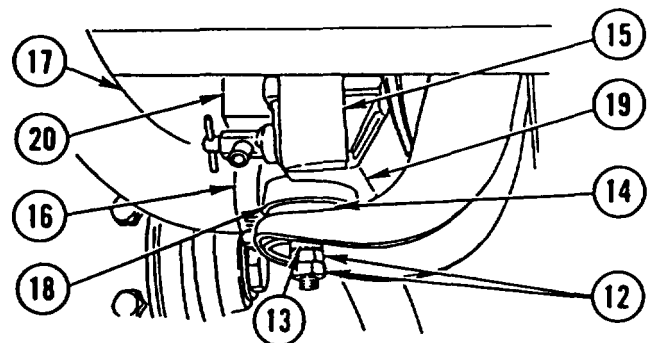

RADIATOR REPLACEMENT (CONT)

7. REMOVE four bolts (21), four lock washers (22), and BAFFLE (23). DISCARD lock WASHERS.

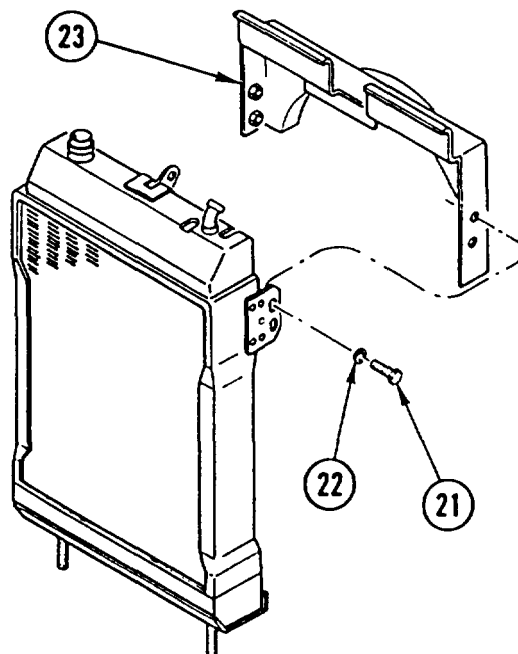

INSTALLATION

1. INSTALL BAFFLE (1), four new lock washers (2), and four bolts (3).

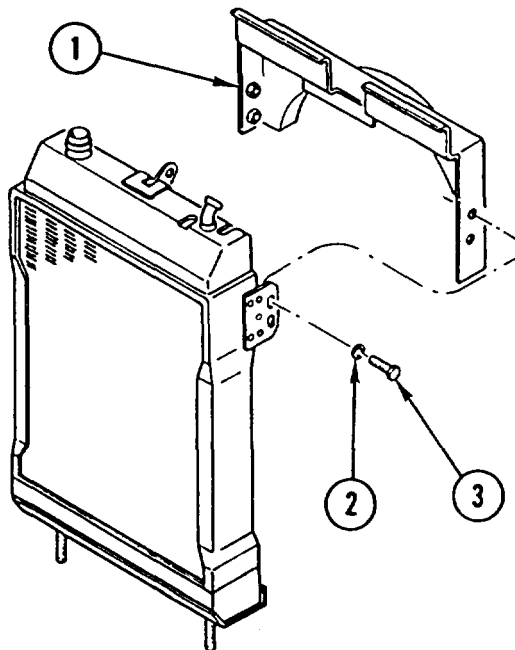

RADIATOR REPLACEMENT (CONT)

2. INSTALL DRAINCOCK (4), two mounts (5), two retainers (6), RADIATOR (7), and filler (8).
3. INSTALL two bushings (9), two clamps (10), two new cotter pins (11), BRACKET (12), two bolts (13), and new lock nut (14).

CAUTION

Prior to tightening lock nuts, make sure radiator is 5/8-3/4 in. (16-19 mm) away from fan blade to prevent damage to equipment.

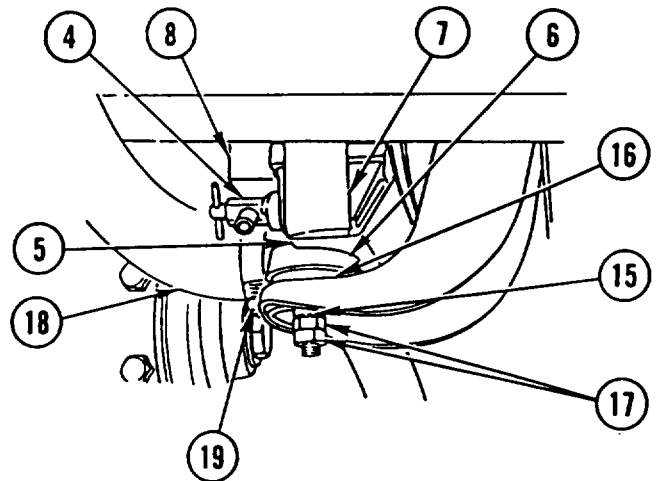

4. INSTALL two washers (15), two MOUNTS (16), and four new lock nuts (17).
5. CLOSE DRAINCOCK (4).
6. CONNECT HOSE (18) and TIGHTEN CLAMP (19).
7. INSTALL two HOSES (20 and 21) and TIGHTEN two CLAMPS (22 and 23).

NOTE

Follow-on Maintenance:
 Fill cooling system (page 4-87).
 Install outside engine hood (page 4-388).

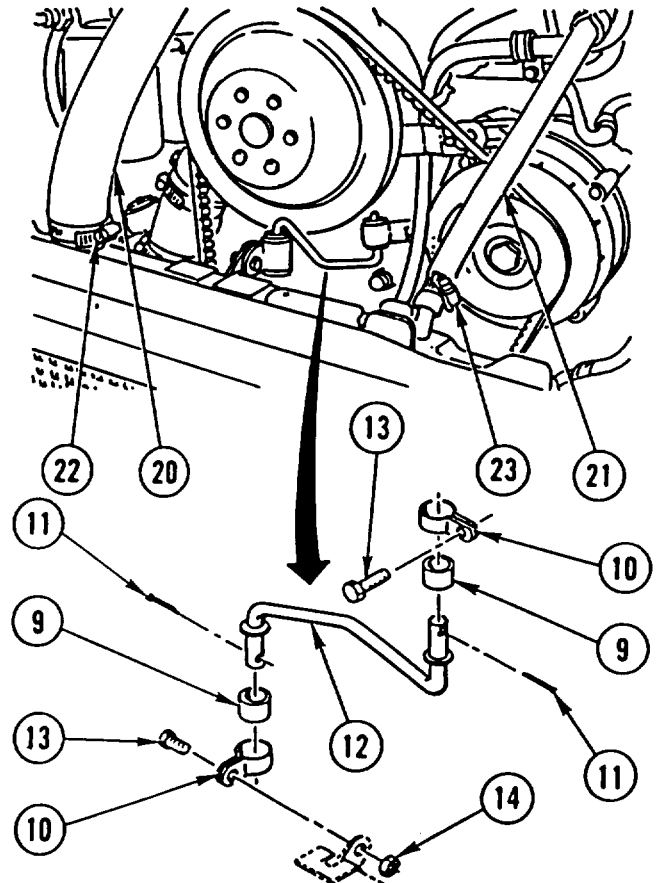

COOLANT EXPANSION TANK REPLACEMENT

This task covers: a. Removal b. Installation

INITIAL SETUP

Tools and Special Equipment:

Shop Equipment, SC 4910-95-CL-A74
 Tool Kit, SC 5180-90-CL-N26

Equipment Condition:

Reference	Condition Description
Page 4-389	Inside Engine Hood Removed
Page 4-87	Cooling System Drained

REMOVAL

NOTE

Tag lines prior to disconnecting to aid in connecting.

1. LOOSEN three CLAMPS (1) and DISCONNECT three HOSES (2).
2. REMOVE HOSE (3) from expansion tank (4).
3. REMOVE NUT (5) and SWING CLAMP (6) out of the way. REMOVE expansion TANK (4).

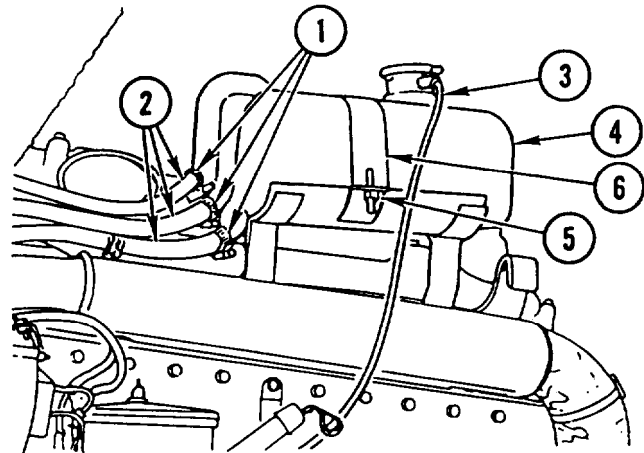

INSTALLATION

1. INSTALL expansion TANK (4). SWING CLAMP (6) over top of tank and INSTALL NUT (5).
2. INSTALL HOSE (3) on expansion tank (4).
3. CONNECT three HOSES (2) and TIGHTEN three CLAMPS (1).

NOTE

Follow-on Maintenance:
 Fill cooling system (page 4-87).
 Install inside engine hood (page 4-389)

COOLANT EXPANSION TANK SUPPORT REPLACEMENT

This task covers: a. Removal b. Installation

INITIAL SETUP

Tools and Special Equipment:

Tool Kit, SC 5180-90-CL-N26

Materials/Parts:

Washer, Seal Ring (3)

Equipment Condition:

Reference

Page 4-85

Condition Description

Exhaust Manifold
Screening Plate Removed

REMOVAL

1. REMOVE NUT (1) and SWING CLAMP (2) out of the way.
2. MOVE expansion TANK (3) to the side.
3. REMOVE two bolts (4), three seal ring washers (5), and SWING two mounting PLATES (6) out of the way. DISCARD seal ring WASHERS.
4. LOOSEN two BOLTS (7) and REMOVE SUPPORT (8).
5. REMOVE hinge pin (9) and CLAMP (2).

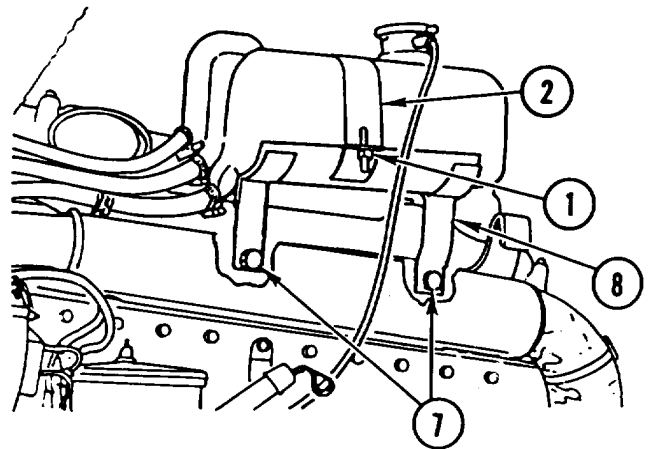

INSTALLATION

1. INSTALL CLAMP (2) and hinge pin (9).
2. INSTALL SUPPORT (8) and TIGHTEN two BOLTS (7).
3. SWING two mounting PLATES (6) into position and INSTALL three new seal ring washers (5) and two BOLTS (4). TIGHTEN BOLTS to 19 lb-ft (25 N•m).
4. MOVE expansion TANK (3) over support (8).
5. SWING CLAMP (2) over top of expansion tank (3) and INSTALL NUT (1).

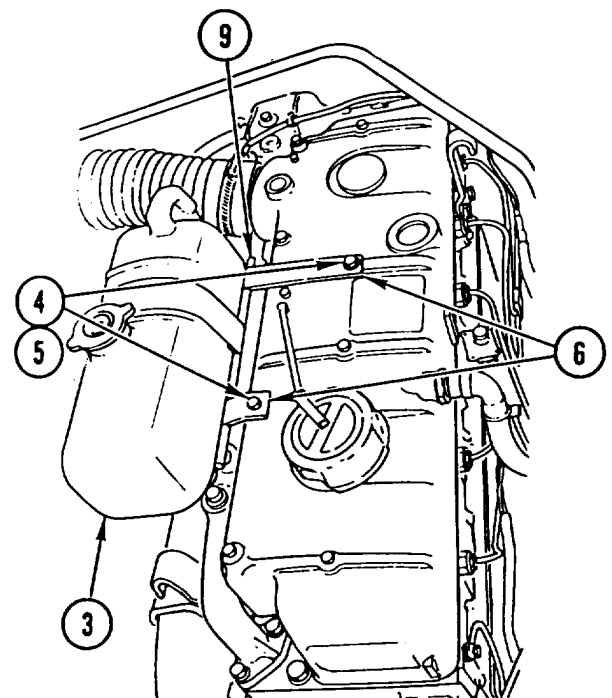

NOTE

Follow-on Maintenance:
Install exhaust manifold screening plate (page 4-85).

COOLANT HOSES AND CLAMPS REPLACEMENT

This task covers: a. Removal b. Installation

INITIAL SETUP

Tools and Special Equipment:

Shop Equipment, SC 4910-95-CL-A74
 Tool Kit, SC 5180-90-CL-N26

Equipment Condition:

Reference	Condition Description
Page 4-388	Outside Engine Hood Removed
Page 4-418	Cab Tilted
Page 4-87	Cooling System Drained

REMOVAL

NOTE

Tag all lines prior to removal to aid in installation.

REMOVE coolant HOSES and CLAMPS using illustration and legend as a guide.

INSTALLATION

INSTALL coolant HOSES and CLAMPS using illustration and legend as a guide.

NOTE

Follow-on Maintenance:

- Fill cooling system (page 4-87).
- Lower cab (page 4-418).
- Install outside engine hood (page 4-388).

COOLANT HOSES AND CLAMPS REPLACEMENT (CONT)

LEGEND

- | | |
|-------------|---------------|
| 1 Hose | 9 Pipe |
| 2 Clamp (2) | 10 Clamp (2) |
| 3 Clamp (2) | 11 Hose |
| 4 Hose | 12 Screw |
| 5 Clamp (2) | 13 Clamp (2) |
| 6 Clamp | 14 Pipe |
| 7 Hose | 15 Nut |
| 8 Hose | 16 Nut (2) |
| | 17 Screw (2) |
| | 18 Washer (2) |
| | 19 Clamp (4) |
| | 20 Clamp |
| | 21 Screw |
| | 22 Clamp (2) |
| | 23 Hose |
| | 24 Clamp (2) |
| | 25 Hose |
| | 26 Clamp |
| | 27 Pipe |
| | 28 Clamp (2) |
| | 29 Hose |

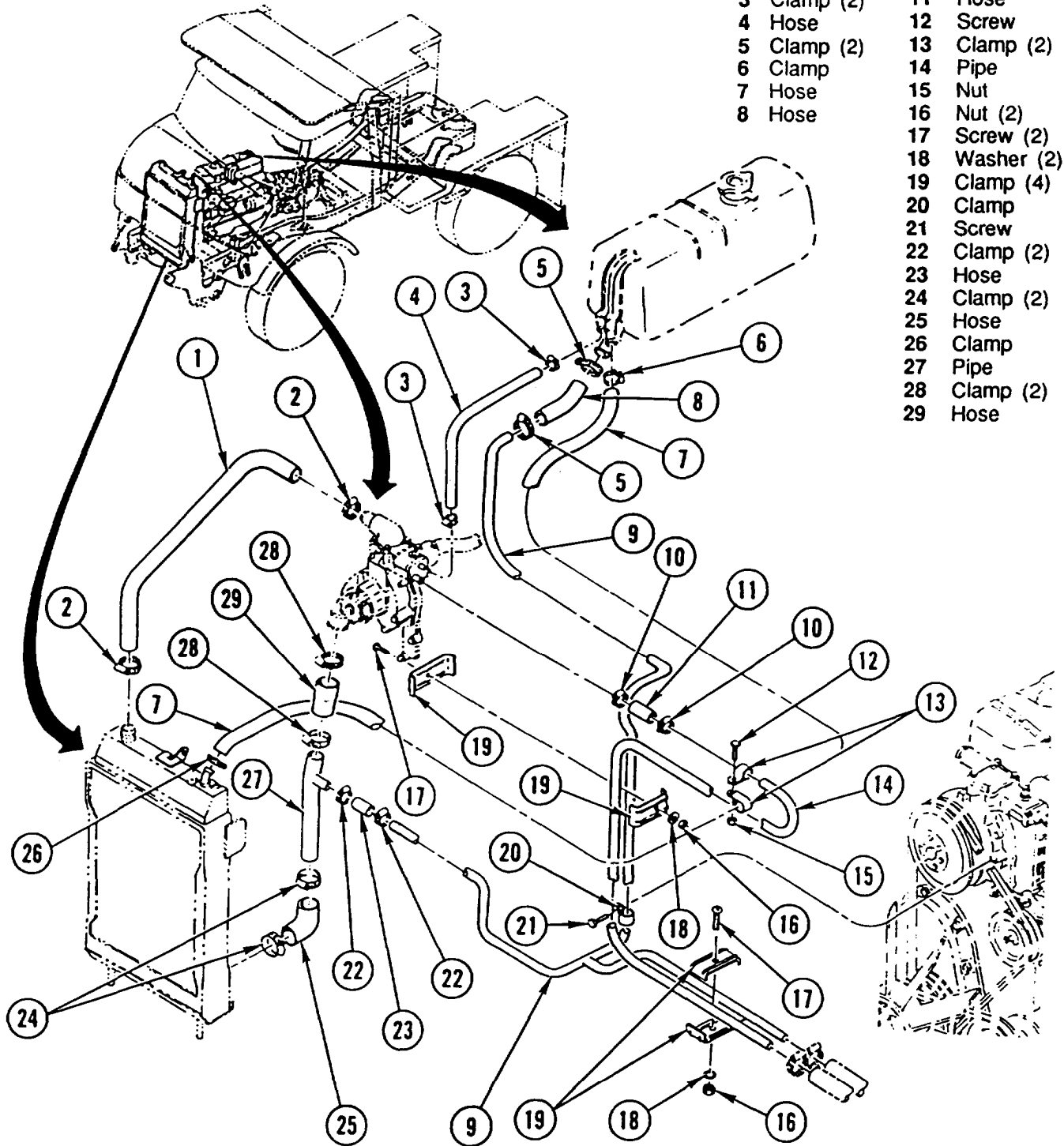

COOLANT THERMOSTAT REPLACEMENT

This task covers: a. Removal b. Installation

INITIAL SETUP

Tools and Special Equipment:

Shop Equipment, SC 4910-95-CL-A74
Tool Kit, SC 5180-90-CL-N26

Materials/Parts:

Gasket

Equipment Condition:

Reference	Condition Description
Page 4-87	Cooling System Drained
Page 4-388	Outside Engine Hood Removed

REMOVAL

1. REMOVE four SCREWS (1) and MOVE water OUTLET (2) to the side.
2. REMOVE and DISCARD GASKET (3).
3. REMOVE THERMOSTAT (4) from thermostat housing (5).

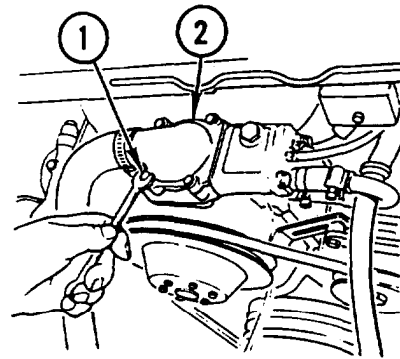

INSTALLATION

CAUTION

Make sure all gasket material has been removed from water outlet and thermostat housing to prevent damage to equipment.

1. INSTALL THERMOSTAT (4) in thermostat housing (5).
2. INSTALL new gasket (3), water OUTLET (2), and four screws (1). TIGHTEN SCREWS to 12 lb-ff (15 N•m).

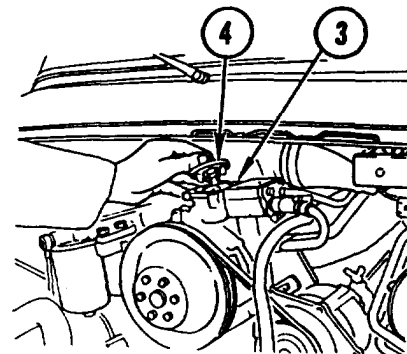

NOTE

Follow-on Maintenance:
Fill cooling system (page 4-87).
Install outside engine hood (page 4-388).

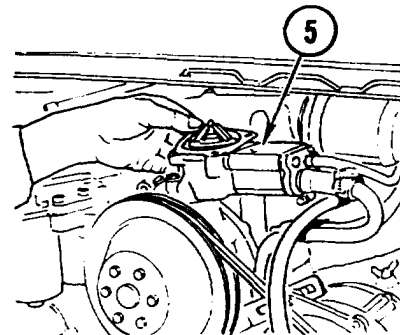

COOLANT WATER OUTLET REPLACEMENT

This task covers: a. Removal b. Installation

INITIAL SETUP

Tools and Special Equipment:

Shop Equipment, SC 4910-95-CL-A74
Tool Kit, SC 5180-90-CL-N26

Materials/Parts:

Gasket
Gasket (2)

Equipment Condition:

Reference

Page 4-100

Page 4-87

Condition Description

Coolant Thermostat
Removed

Cooling System Drained

REMOVAL

1. REMOVE two SCREWS (1).
2. MOVE CONNECTOR (2) ASIDE and REMOVE and DISCARD GASKET (3).
3. REMOVE two screws (4), screw (5), water OUTLET (6), and two gaskets (7 and 8). DISCARD GASKETS.

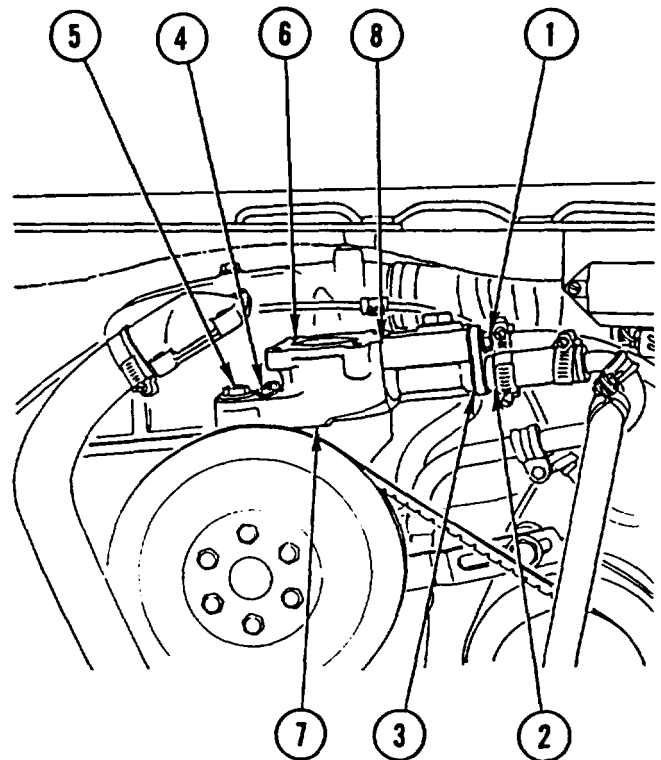

INSTALLATION

CAUTION

Make sure all gasket material has been removed from mating surfaces to prevent damage to equipment.

1. INSTALL two new gaskets (7 and 8), water OUTLET (6), screw (5), and two screws (4).
2. INSTALL new gasket (3), CONNECTOR (2), and two screws (1). TIGHTEN SCREWS to 22 lb-ft (30 Nžm).

NOTE

Follow-on Maintenance:

Install coolant thermostat (page 4-100).
Fill cooling system (page 4-87).

WATER MANIFOLD AND GASKET REPLACEMENT

This task covers: a. Removal b. Installation

INITIAL SETUP

Tools and Special Equipment:

Shop Equipment, SC 4910-95-CL-A74
 Tool Kit, SC 5180-90-CL-N26

Materials/Parts:

Gasket (2)

Gasket (2)

Equipment Condition:

Reference

Page 4-418

Page 4-87

Page 4-96

Page 4-203

Condition Description

Cab Tilted

Cooling System Drained

Coolant Expansion Tank
 Removed

Water Temperature
 Sending Unit Removed

REMOVAL

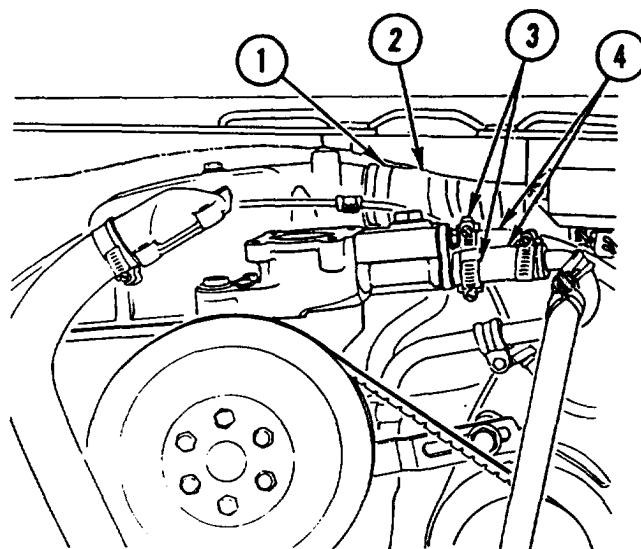

1. LOOSEN CLAMP (1) and DISCONNECT BELLOWS (2).

NOTE

Tag lines prior to disconnecting to aid in connecting.

2. LOOSEN two CLAMPS (3) and DISCONNECT two HOSES (4).
3. REMOVE two screws (5), CONNECTOR (6), and gasket (7). DISCARD GASKET.
4. REMOVE four screws (8), cooling LINE (9), and three gaskets (10 and 11). DISCARD GASKET.

WATER MANIFOLD AND GASKET REPLACEMENT (CONT)

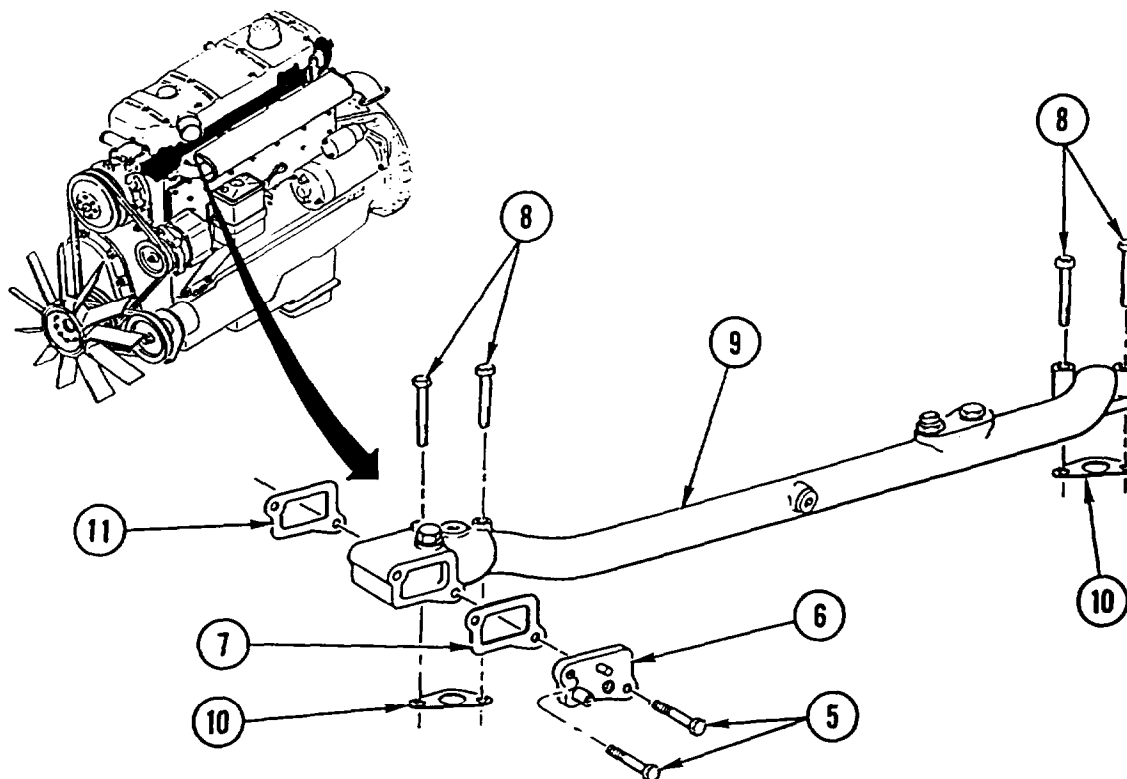

INSTALLATION

CAUTION

Make sure all gasket material has been removed from mating surfaces to prevent damage to equipment.

1. INSTALL cooling LINE (9), three new gaskets (10 and 11), and four screws (8). TIGHTEN SCREWS to 22 lb-ft (30 N•m).
2. INSTALL CONNECTOR (6), new gasket (7), and two screws (5).
3. CONNECT two HOSES (4) and TIGHTEN two CLAMPS (3).
4. CONNECT BELLOWS (2) and TIGHTEN CLAMP (1).

NOTE

Follow-on Maintenance:

Install coolant expansion tank (page 4-96).
 Install water temperature sending unit (page 4-203).
 Fill cooling system (page 4-87).
 Lower cab (page 4-418).

WATER PUMP REPLACEMENT

This task covers: a. Removal b. Installation

INITIAL SETUP

Tools and Special Equipment:

Tool Kit, SC 5180-90-CL-N26

Materials/Parts:

Gasket

Equipment Condition:

Reference	Condition Description
Page 4-388	Outside Engine Hood Removed
Page 4-87	Cooling System Drained
Page 4-101	Coolant Water Outlet Removed
Page 4-106	Fan Belt Removed

REMOVAL

1. LOOSEN CLAMP (1) and Disconnect SLEEVE (2).
2. REMOVE five screws (3), water PUMP (4), and gasket (5). DISCARD GASKET.

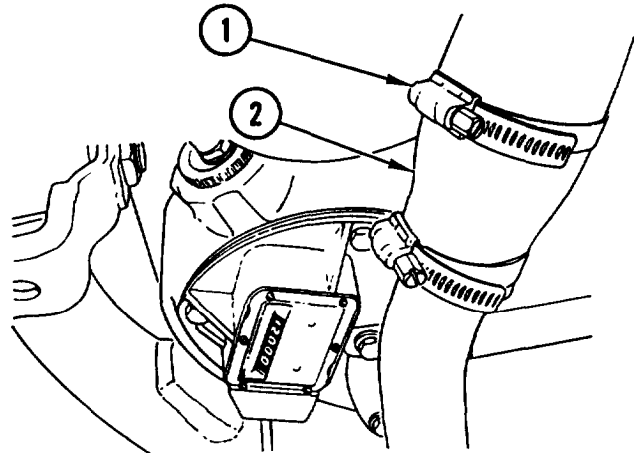

INSTALLATION

CAUTION

Make sure all gasket material has been removed from mating surfaces to prevent damage to equipment.

1. INSTALL new gasket (5), water PUMP (4), and five screws (3). TIGHTEN SCREWS to 37 lb-ft (50 N•m).
2. CONNECT SLEEVE (2) and TIGHTEN CLAMP (1).

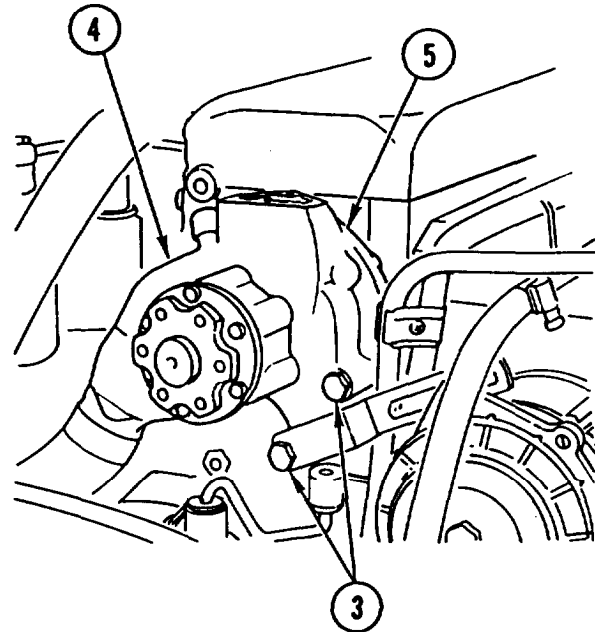

NOTE

Follow-on Maintenance:
 Install coolant water outlet (page 4-101).
 Fill cooling system (page 4-87).
 Install fan belt (page 4-106).
 Install outside engine hood (page 4-388).

FAN IMPELLER REPLACEMENT

This task covers: a. Removal b. Installation

INITIAL SETUP

Tools and Special Equipment:

Tool Kit, SC 5180-90-CL-N26

Equipment Condition:

Reference	Condition Description
Page 4-92	Radiator Removed
Page 4-506	Front Hydraulic Pump Belt Removed

REMOVAL

REMOVE six screws (1) and fan IMPELLER (2).

INSTALLATION

INSTALL fan IMPELLER (2) and six screws (1).
TIGHTEN SCREWS to 44 lb-ft (60 N•m).

NOTE

Follow-on Maintenance:
Install front hydraulic pump belt (page 4-506).
Install radiator (page 4-92).

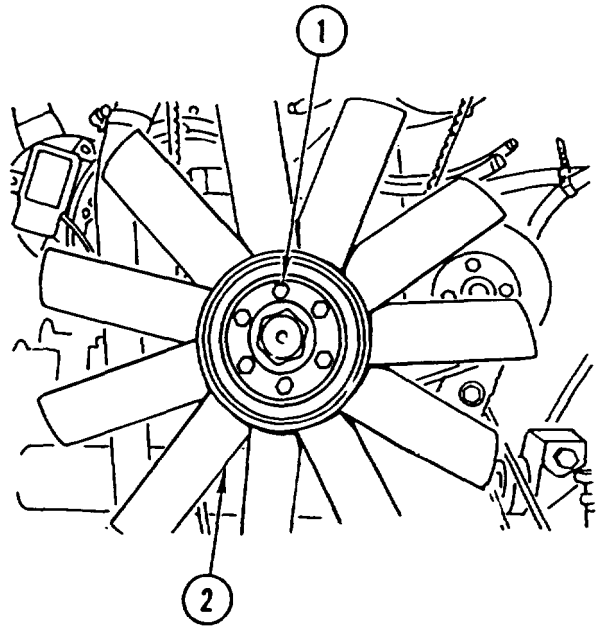

FAN BELT REPLACEMENT

This task covers: a. Removal b. Installation

INITIAL SETUP

Tools and Special Equipment:

Tool Kit, SC 5180-90-CL-N26

Equipment Condition:

Reference

Page 4-506

Condition Description

Front Hydraulic Pump
Belt Removed

REMOVAL

1. LOOSEN two SCREWS (1 and 2).

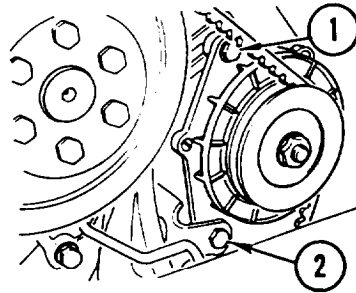

2. MOVE ALTERNATOR (3) in toward engine.

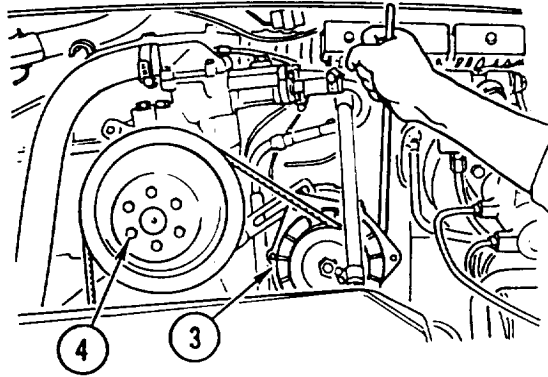

3. REMOVE six screws (4), pulley (5), and fan BELT (6).

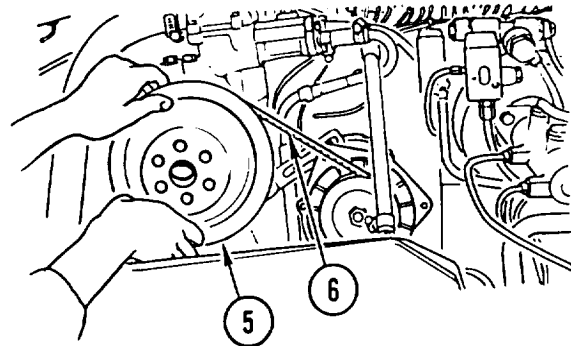

FAN BELT REPLACEMENT (CONT)

INSTALLATION

1. INSTALL fan BELT (1), pulley (2), and six screws (3).

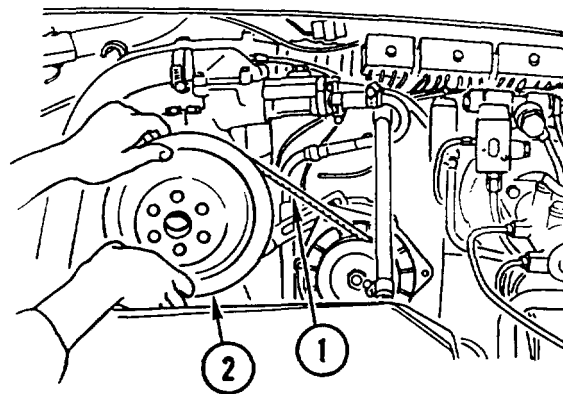

2. MOVE ALTERNATOR (4) outward to TIGHTEN BELT to tension limit of approximately 1/2 in. (10-15 mm).

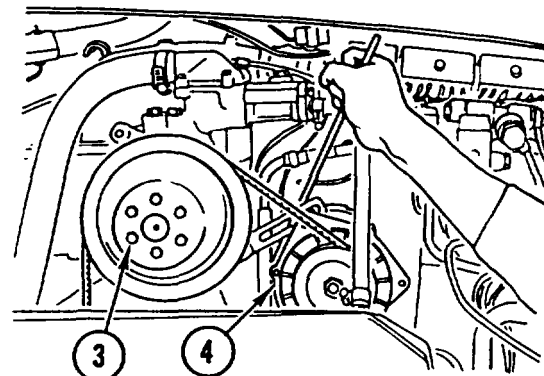

3. TIGHTEN two SCREWS (5 and 6).

NOTE

Follow-on Maintenance:
Install front hydraulic pump belt
(page 4-506).

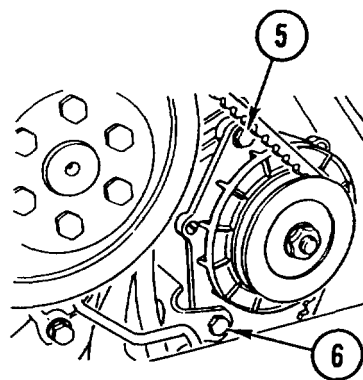

FAN BELT ADJUSTMENT

This task covers: Adjustment

INITIAL SETUP

Tools and Special Equipment:

Tool Kit, SC 5180-90-CL-N26

Equipment Condition:

Reference

Page 4-388

Condition Description

Outside Engine Hood
Removed

ADJUSTMENT

1. Loosen two screws (1 and 2).
2. Move alternator (3) outward to tighten belt to tension limit of approximately 1/2 in. (10-15 mm).
3. Tighten two screws (1 and 2).
4. Check belt tension. If necessary, repeat steps 1 and 2 to maintain 1/2-in. tension limit.

NOTE

Follow-on Maintenance:
Install outside engine hood (page 4-388).

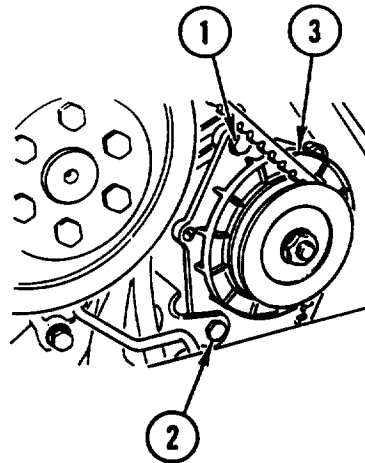

Section VI. ELECTRICAL SYSTEM MAINTENANCE

OVERVIEW

This section illustrates and describes procedures for maintenance of the electrical system and related parts. A list of tasks contained in this section is shown below.

	Page
Alternator and Alternator Bracket Replacement	4-112
Starter Replacement	4-117
Starter Solenoid Replacement	4-119
Polarity Breaker and Suppressor Filter Mounting Bracket Replacement	4-120
Polarity Breaker Replacement	4-121
Turn Signal Lever Replacement	4-122
Press-To-Test Switch Replacement.	4-123
Indicator (Gage) Replacement	4-124
Tachometer Replacement	4-128
Ignition Switch Replacement	4-131
Windshield Wiper/Washer Switch Replacement	4-132
Starter Switch Replacement	4-133
Hazard Warning Switch Replacement	4-134
Ammeter Replacement	4-135
Cold Start Switch Replacement	4-136
Master Light Switch Replacement	4-137
Instrument Cluster Panel Light Replacement	4-138
Windshield Heater Control Switch Replacement	4-139
Windshield Wiper/Washer Switch Relay Replacement	4-140
Warning Delay Relay Replacement	4-141
Hydraulic Suspension Lockout Controls Replacement	4-142
Auxiliary Light Control Switch Replacement	4-146
Hydraulic Oil Cooler Thermal Switch Replacement	4-147
Relay Replacement	4-150

	Page
Bucket and Auxiliary Throttle Switches Replacement	4-151
Throttle Control Switch Replacement	4-154
Auxiliary Throttle Switch Replacement	4-156
Throttle Control Switch Replacement	4-158
Tool and Work Light Switches Replacement	4-162
Fuse Holder Replacement	4-166
Brake Light Diode Replacement	4-168
Fuse Replacement	4-169
Low Oil Pressure and High Water Temperature Alarm Replacement	4-170
Main (Master) Disconnect Switch Replacement	4-171
Slave Receptacle Replacement	4-172
Headlight Replacement	4-173
Auxiliary Headlight Replacement	4-175
Auxiliary Headlight Adjustment	4-179
Front Blackout Light Replacement and Repair	4-181
Front Composite Light Replacement and Repair	4-183
Work Light Replacement and Repair	4-186
Crane Mast Floodlight Replacement and Repair	4-188
Rear Composite Stoplight/taillight Replacement and Repair	4-190
Dome Light Replacement	4-195
Turn Signal Flasher Relay Replacement	4-196
Engine Start Switch Replacement	4-199
Brake Light Switch Replacement	4-200
Starter Lockout/Intermediate Speed Shift Sending Unit Replacement	4-201
Oil Pressure Sender Replacement	4-202
Water Temperature Gage Replacement	4-203
Fuel Level Gage Replacement	4-204
Air Cleaner Restrictor Indicator Switch Replacement	4-205

	Page
Power Take-Off Indicator Switch Replacement	4-206
Differential Lock Indicator Switch Replacement	4-207
Backup Alarm Switch Replacement.	4-208
Intermediate Speed Shift and Indicator Switch Replacement	4-209
Parking Brake Switch Replacement.	4-210
STE/ICE-R Resistor Replacement	4-211
STE/ICE-R Fuel Pressure Switch Replacement	4-212
STE/ICE-R Shunt Replacement	4-213
Backup Alarm Replacement	4-214
Horn, Low Beam/High Beam Switch Replacement	4-215
Horn Replacement	4-218
Battery Replacement	4-219
Battery Cables Replacement	4-221
Battery Box Replacement	4-226
Battery Box Repair	4-228
Trailer Connection Replacement	4-230
Front Disc Brake Pad Indicator Wiring Harness Replacement	4-231
Suppressor Filters Replacement	4-235
Engine Temperature Switch Replacement	4-238

ALTERNATOR AND ALTERNATOR BRACKET REPLACEMENT

This task covers: a. Removal b. Installation

INITIAL SETUP

Tools and Special Equipment:

Tool Kit, SC 5180-90-CL-N26

Materials/Parts:

Washer, Lock (10)

Equipment Condition:

Reference	Condition Description
Page 4-418	Cab Tilted

REMOVAL

1. REMOVE NUT (1), lock washer (2), SCREW (3), and washer (4). DISCARD lock WASHER.
2. REMOVE V-BELT (5) from alternator (6).

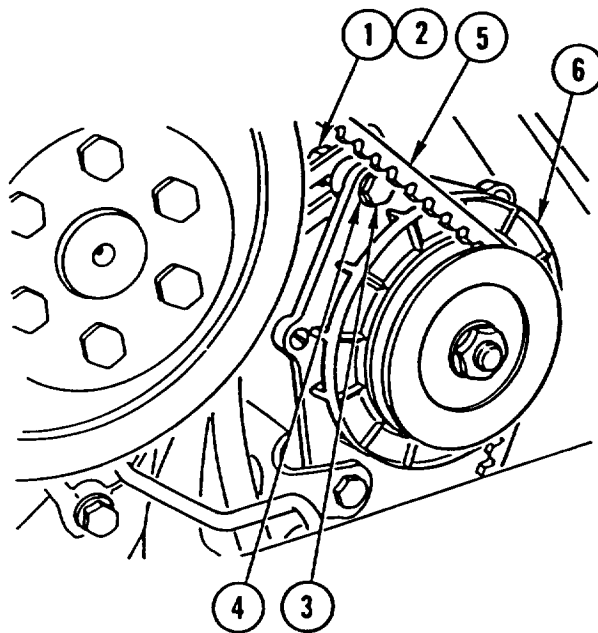

ALTERNATOR AND ALTERNATOR BRACKET REPLACEMENT (CONT)

3. REMOVE NUT (7) and lock washer (8) and SET BRACKET (9) ASIDE DISCARD lock WASHER.

NOTE

Tag and mark all wires prior to disconnecting to aid in connecting.

4. REMOVE NUT (10) and lock washer (11) and DISCONNECT two WIRES (12). DISCARD lock WASHER.
5. REMOVE NUT (13) and lock washer (14) and DISCONNECT WIRE (15). DISCARD lock WASHER.
6. PULL BACK two BOOTS (16).
7. REMOVE NUT (17) and lock washer (18) and DISCONNECT two WIRES (19). DISCARD lock WASHER.
8. REMOVE NUT (20) and lock washer (21) and DISCONNECT WIRE (22). DISCARD lock WASHER.
9. REMOVE two NUTS (23) and two lock washers (24) and DISCONNECT three ground STRAPS (25). DISCARD lock WASHERS.

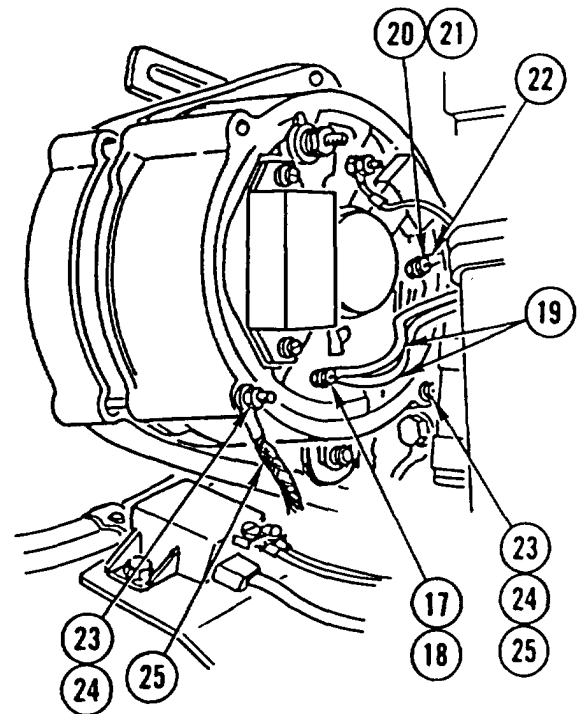
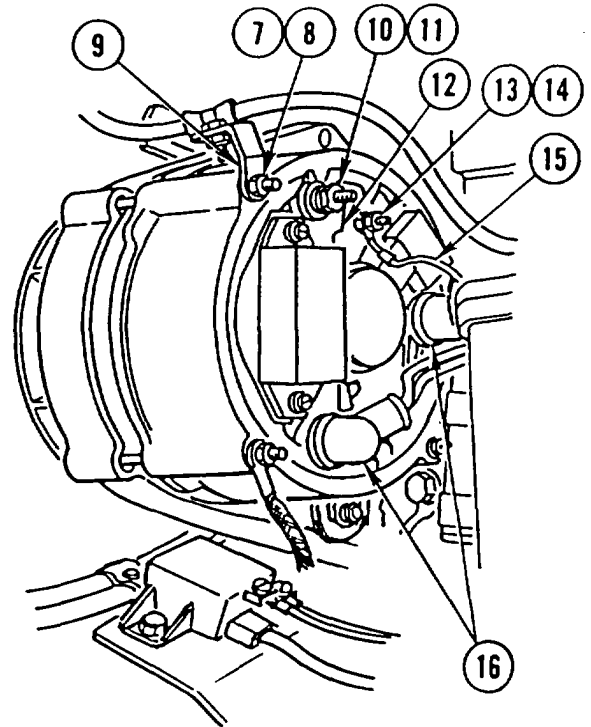

ALTERNATOR AND ALTERNATOR BRACKET REPLACEMENT (CONT)

10. REMOVE screw (26), lock washer (27), and ALTERNATOR (6). DISCARD lock WASHER.

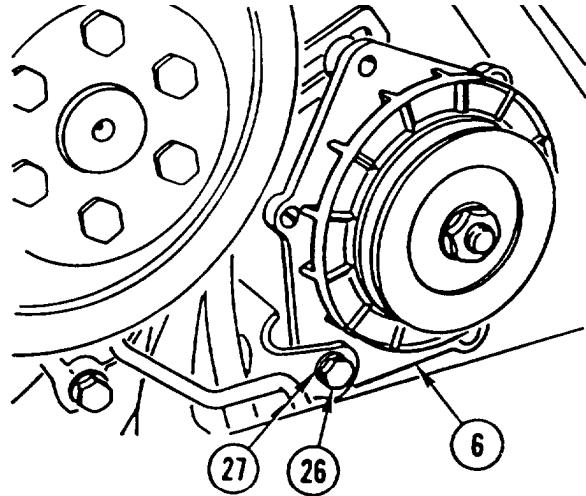

11. REMOVE bolt (28), ground STRAP (25), and two socket head bolts (29). SET BRACKET (30) ASIDE and REMOVE alternator BRACKET (31).

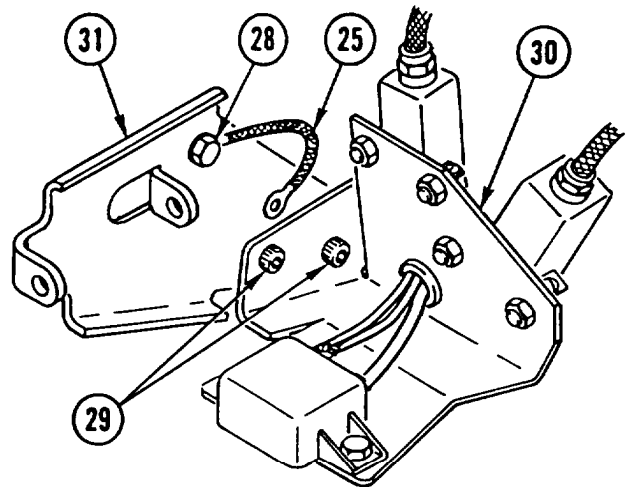

12. REMOVE NUT (32) and lock washer (33). DISCARD lock WASHER.

13. REMOVE PULLEY (34), woodruff key (35), and IMPELLER (36).

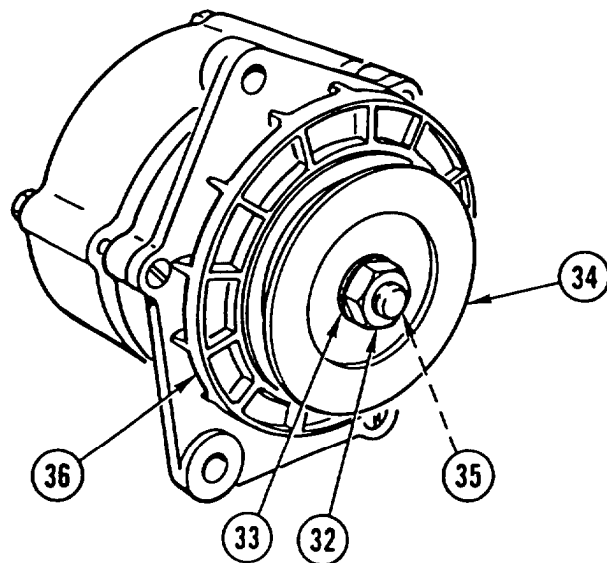

ALTERNATOR AND ALTERNATOR BRACKET REPLACEMENT (CONT)

INSTALLATION

1. INSTALL IMPELLER (1), woodruff key (2), and PULLEY (3).
2. INSTALL new lock washer (4) and NUT (5).

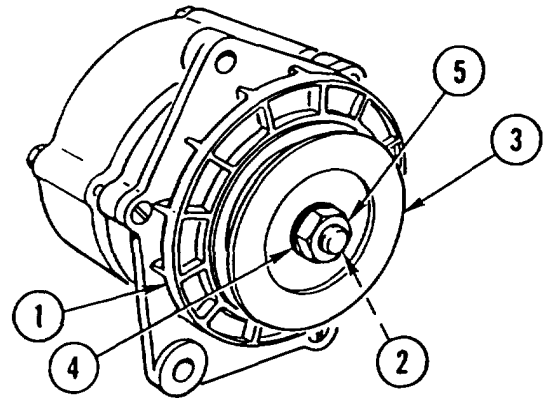

3. INSTALL alternator BRACKET (6), BRACKET (7), two socket head bolts (8), ground STRAP (9), and bolt (10).

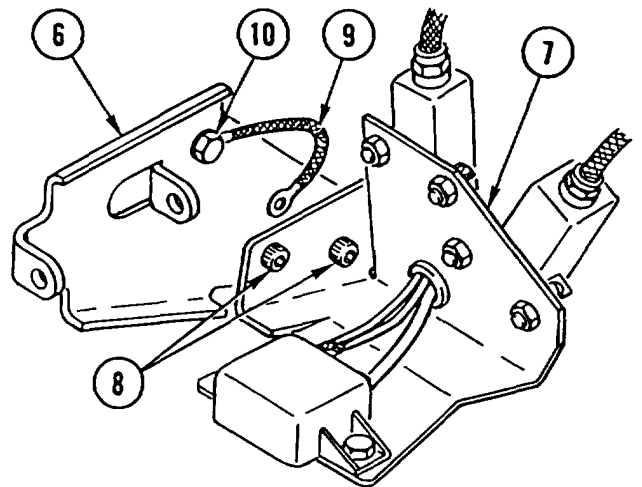

4. CONNECT three ground STRAPS (9) and INSTALL two new lock washers (11) and two NUTS (12) on alternator (13).

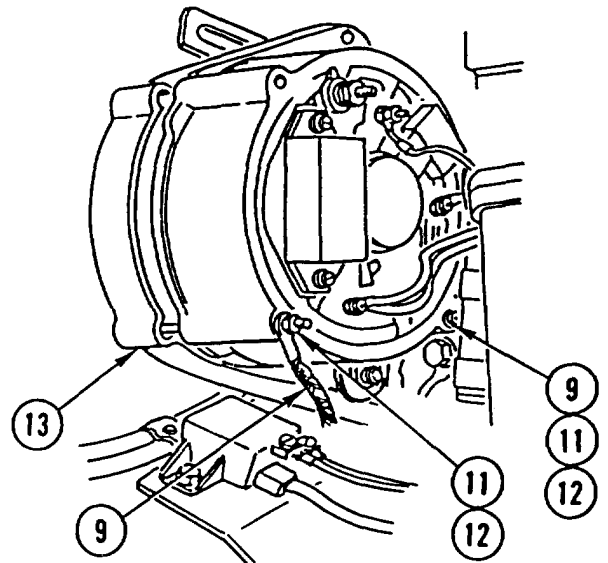

ALTERNATOR AND ALTERNATOR BRACKET REPLACEMENT (CONT)

5. INSTALL ALTERNATOR (13), new lock washer (14), and screw (15).

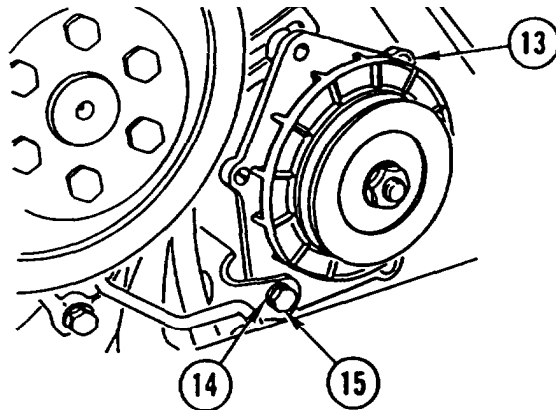

6. CONNECT WIRE (16) and INSTALL new lock washer (17) and NUT (18).
7. CONNECT two WIRES (19) and INSTALL new lock washer (20) and NUT (21).
8. PUSH two BOOTS (22) BACK INTO POSITION.
9. CONNECT WIRE (23) and INSTALL new lock washer (24) and NUT (25).
10. CONNECT two WIRES (26) and INSTALL new lock washer (27) and NUT (28).
11. INSTALL BRACKET (29), new lock washer (30), and nut (31).

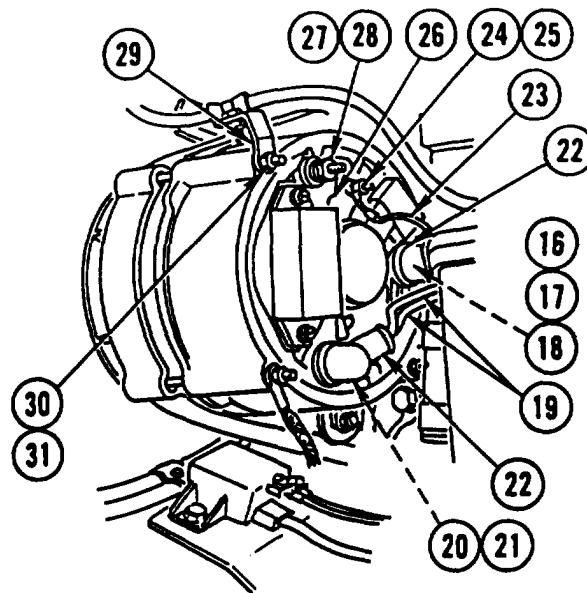

12. INSTALL V-BELT (32) on alternator (13).
13. INSTALL washer (33), SCREW (34), new lock washer (35), and NUT (36).

NOTE

Follow-in Maintenance:
Lower cab (page 4-418).

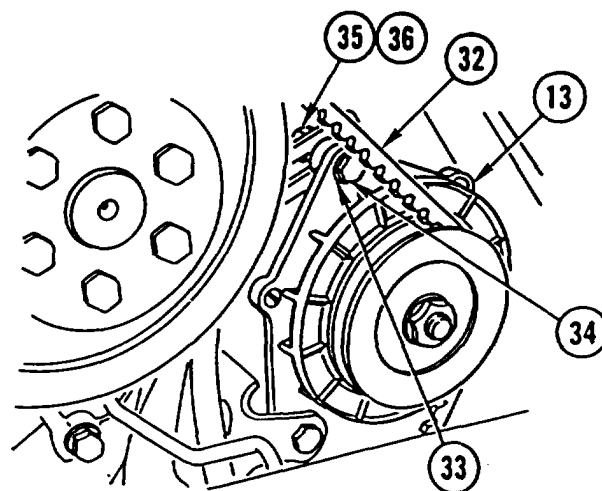

STARTER REPLACEMENT

This task covers: a. Removal b. Installation

INITIAL SETUP

Tools and Special Equipment:

Tool Kit, SC 5180-90-CL-N26

Materials/Parts:

Washer, Lock

Washer, Lock (2)

Equipment Condition:

Reference

Page 2-24

Page 4-389

Condition Description

Batteries Disconnected

Inside Engine Hood Removed

REMOVAL

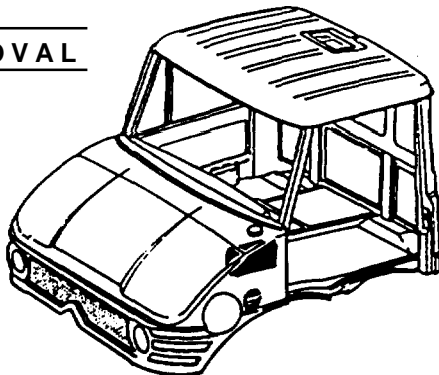

1. REMOVE eight screws (1), eight washers (2), and COVER (3).

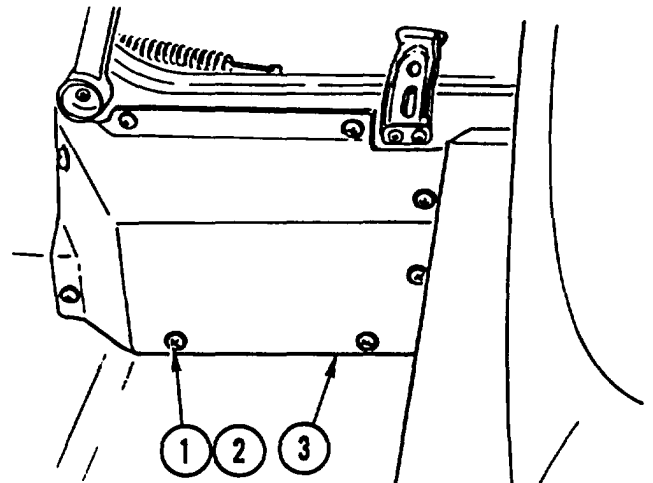

2. REMOVE screw (4) and cable CLAMP (5) from starter (6).

NOTE

Tag all wires and cables prior to removal to aid in installation.

3. REMOVE screw (7), lock washer (8), and two WIRES (9). DISCARD lock WASHER.
4. REMOVE nut (10), lock washer (11), and two CABLES (12). DISCARD lock WASHER.
5. REMOVE nut (13), lock washer (14), and WIRE (15). DISCARD lock WASHER.
6. REMOVE nut (16), two wires (17), and ground STRAP (18).
7. REMOVE two nuts (19) and STARTER (6).

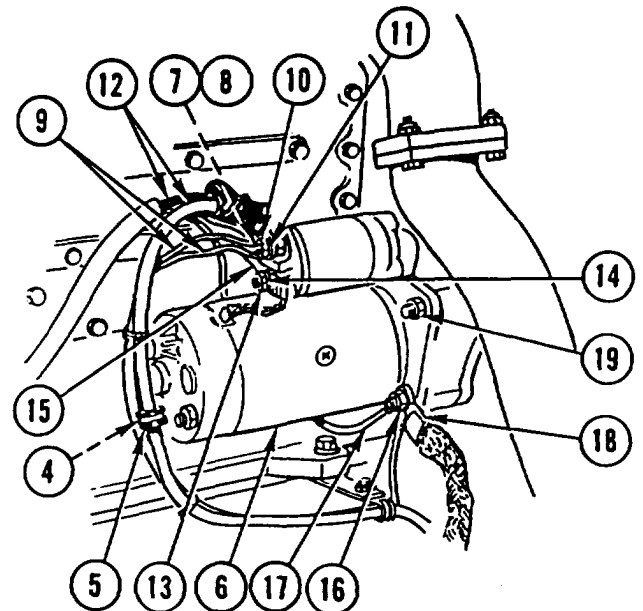

STARTER REPLACEMENT (CONT)

INSTALLATION

1. INSTALL STARTER (1) and two nuts (2).
2. INSTALL ground STRAP (3), two wires (4), and nut (5).
3. INSTALL WIRE (6), new lock washer (7), and nut (8).
4. INSTALL two CABLES (9), new lock washer (10), and nut (11).
5. INSTALL two WIRES (12), new lock washer (13), and screw (14).
6. INSTALL cable CLAMP (15) and screw (16).

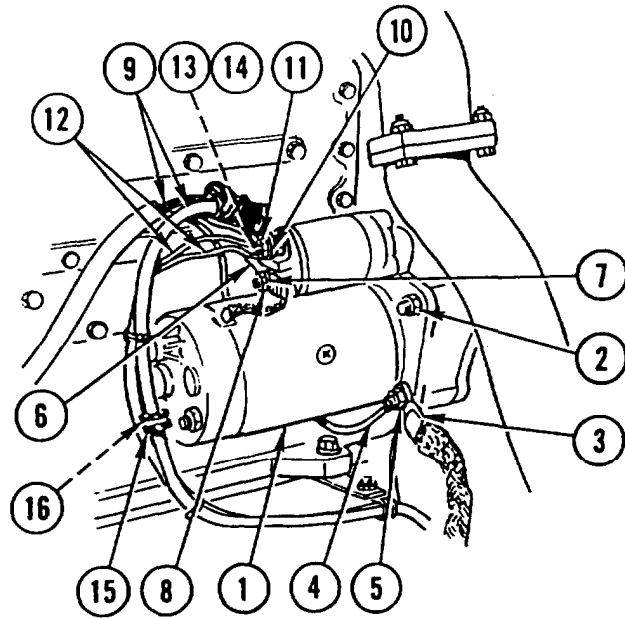

7. INSTALL COVER (17), eight screws (18), and eight washers (19).

NOTE

Follow-on Maintenance:
Connect batteries (page 2-24).
Install inside engine hood (page 4-389).

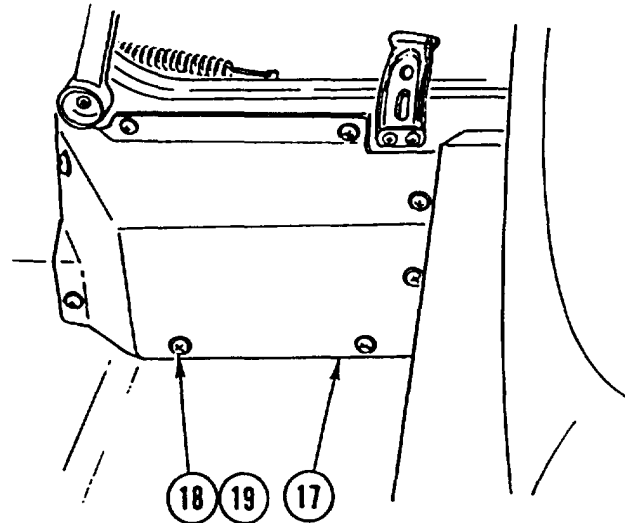

STARTER SOLENOID REPLACEMENT

This task covers: a. Removal b. Installation

INITIAL SETUP

Tools and Special Equipment:

Tool Kit, SC 5180-90-CL-N26

Equipment Condition:

Reference

Page 4-117

Condition Description

Starter Removed

REMOVAL

REMOVE three screws (1) and SOLENOID (2).

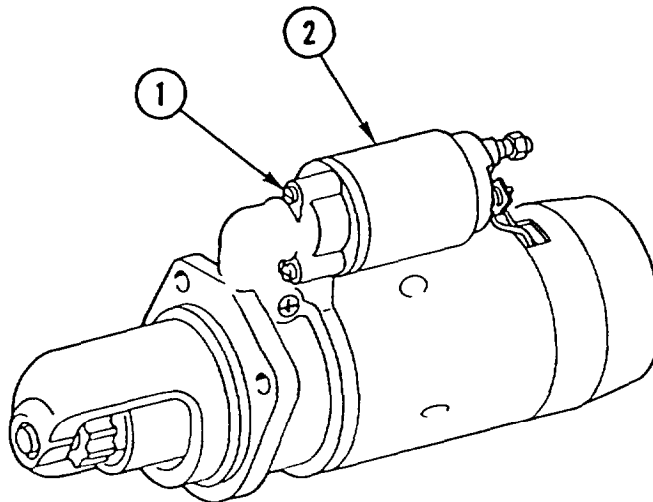

INSTALLATION

INSTALL SOLENOID (2) and three screws (1).

NOTE

Follow-on Maintenance:

Install starter (page 4-117).

POLARITY BREAKER AND SUPPRESSOR FILTER MOUNTING BRACKET REPLACEMENT

This task covers: a. Removal b. Installation

INITIAL SETUP

Tools and Special Equipment:

Tool Kit, SC 5180-90-CL-N26

Materials/Parts:

Washer, Lock (2)

Equipment Condition:

Reference	Condition	Description
Page 4-121	Polarity Breaker	Removed
Page 4-235	Suppressor Filters	Removed

REMOVAL

NOTE

Tag wires prior to removal to aid in installation.

1. REMOVE two WIRES (1) and CONNECTOR (2) from bracket (3).
2. REMOVE two socket head screws (4), two lock washers (5), washer (6), and BRACKET (3) from engine (7). DISCARD lock WASHERS.
3. REMOVE GROMMET (8) from bracket (3).

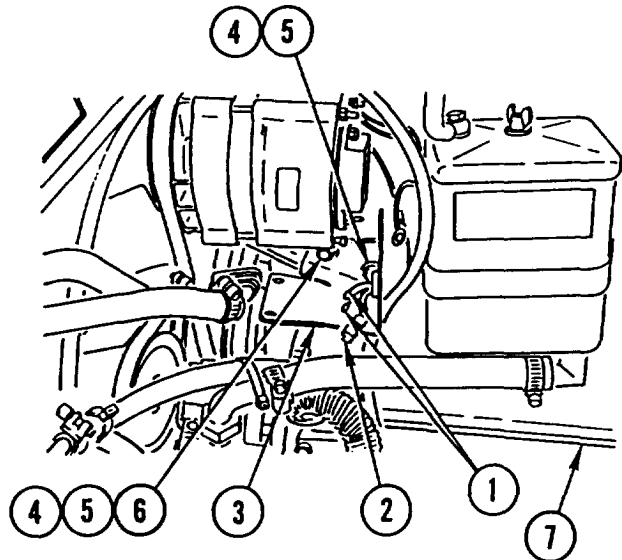

INSTALLATION

1. INSTALL GROMMET (8) in bracket (3).
2. INSTALL BRACKET (3), washer (6), two new lock washers (5), and two socket head screws (4) on engine (7).
3. INSTALL CONNECTOR (2) and two WIRES (1) in bracket (3).

NOTE

Follow-on Maintenance:

Install suppressor filters (page 4-235).
Install polarity breaker (page 4-121).

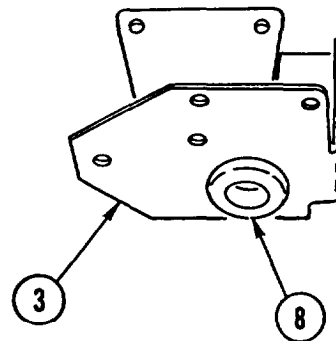

POLARITY BREAKER REPLACEMENT

This task covers: a. Removal b. Installation

INITIAL SETUP

Tools and Special Equipment:

Tools Kit, SC 5180-90-CL-N26

Equipment Condition:

Reference	Condition Description
Page 2-24	Batteries Disconnected
Page 4-418	Cab Tilted

REMOVAL

1. DISCONNECT CONNECTOR (1) from polarity breaker (2).
2. REMOVE two capscrews (3), two washers (4), and POLARITY BREAKER (2) from bracket (5).

NOTE

Tag wires prior to removal to aid in installation.

3. REMOVE two capscrews (6), two clips (7), and two WIRES (8) from polarity breaker (2).

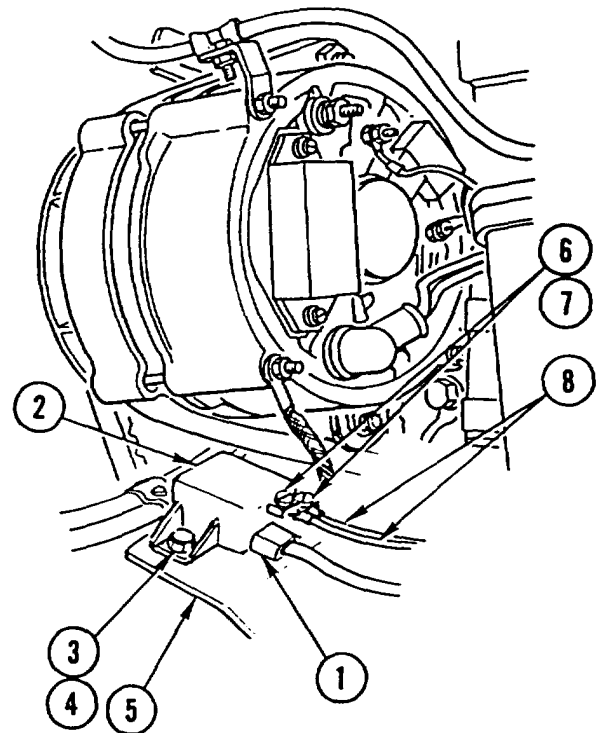

INSTALLATION

1. INSTALL two WIRES (8), two clips (7), and two capscrews (6) on polarity breaker (2).
2. INSTALL POLARITY BREAKER (2), two washers (4), and two capscrews (3) on bracket (5).
3. CONNECT CONNECTOR (1) to polarity breaker (2).

NOTE

Follow-on Maintenance:
 Connect batteries (page 2-24).
 Lower cab (page 4-418).

TURN SIGNAL LEVER REPLACEMENT

This task covers: a. Removal b. Installation

INITIAL SETUP

Tools and Special Equipment:

Tool Kit, SC 5180-90-CL-N26

Equipment Condition:

Reference	Condition Description
Page 4-389	Inside Engine Hood Removed

General Safety instructions:

WARNING

Remove or disconnect batteries and turn vehicle MASTER disconnect switch OFF prior to performing maintenance in immediate battery area or working on electrical system. Such disconnections prevent electrical shock to personnel or equipment.

REMOVAL

1. REMOVE nut (1), washer (2), and turn signal LEVER (3) from dashboard (4).

NOTE

Tag wires prior to disconnecting to aid in connecting.

2. REMOVE six SCREWS (5) and six washers (6) and DISCONNECT six WIRES (7) from lever (3).

INSTALLATION

1. CONNECT six WIRES (7) to turn signal lever (3) and INSTALL six washers (6) and six SCREWS (5).
2. INSTALL LEVER (3) in dashboard (4).
3. INSTALL washer (2) and nut (1).

NOTE

Follow-on Maintenance:
Install inside engine hood (page 4-389).

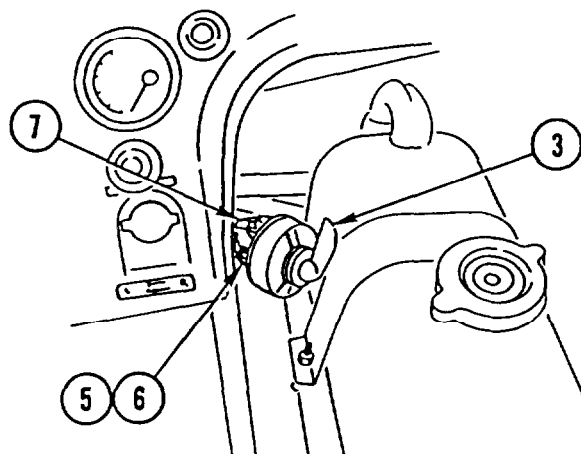
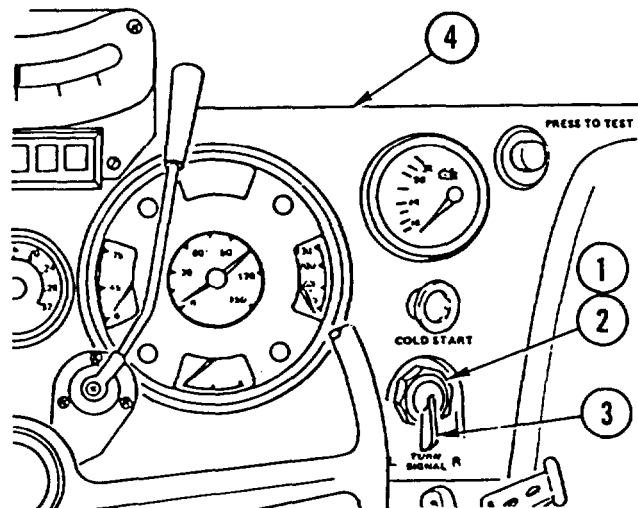

PRESS-TO-TEST SWITCH REPLACEMENT

This task covers: a. Removal b. Installation

INITIAL SETUP

Tools and Special Equipment:

Tool Kit, SC 5180-90-CL-N26

Equipment Condition:

Reference	Condition Description
Page 4-389	Inside Engine Hood Removed

General Safety Instructions:

WARNING

Remove or disconnect batteries and turn vehicle MASTER disconnect switch OFF prior to performing maintenance in immediate battery area or working on electrical system. Such disconnections prevent electrical shock to personnel or equipment.

REMOVAL

NOTE

Tag wires prior to disconnecting to aid in connecting.

1. DISCONNECT two WIRES (1 and 2) from Press-To-Test switch (3).
2. REMOVE NUT (4).
3. REMOVE SWITCH (3) from dashboard (5).

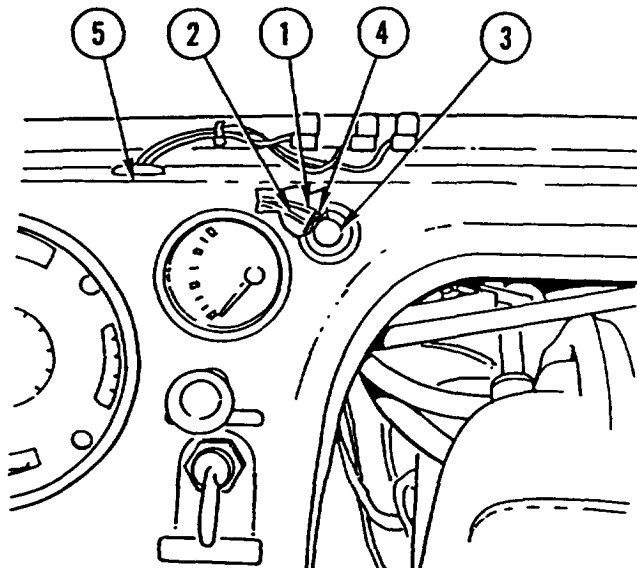

INSTALLATION

1. INSTALL Press-To-Test SWITCH (3) in dashboard (5).
2. INSTALL NUT (4).
3. CONNECT two WIRES (1 and 2) to switch (3).

NOTE

Follow-on Maintenance:
Install inside engine hood (page 4-389).

INDICATOR (GAGE) REPLACEMENT

This task covers: a. Removal b. Installation

INITIAL SETUP

Tools and Special Equipment:

Tool Kit, SC 5180-90-CL-N26

Materials/Parts:

Washer, Lock (2)

Equipment Condition:

Reference	Condition Description
Page 4-388	Outside Engine Hood Removed
Page 4-166	Fuse Holders Removed
Page 2-23	Air Pressure Relieved

General Safety Instructions:

WARNING

- Remove or disconnect batteries and turn vehicle MASTER disconnect switch OFF prior to performing maintenance in immediate battery area or working on electrical system. Such disconnections prevent electrical shock to personnel or equipment.
- Do not disconnect any air system lines or fittings unless vehicle engine is shut off and air system pressure is relieved. To do so could result in injury to personnel.

REMOVAL

NOTE

Tag lines and connectors prior to disconnecting to aid in connecting.

1. DISCONNECT two air HOSES (1 and 2).
2. REMOVE two nuts (3) and two BRACKETS (4).

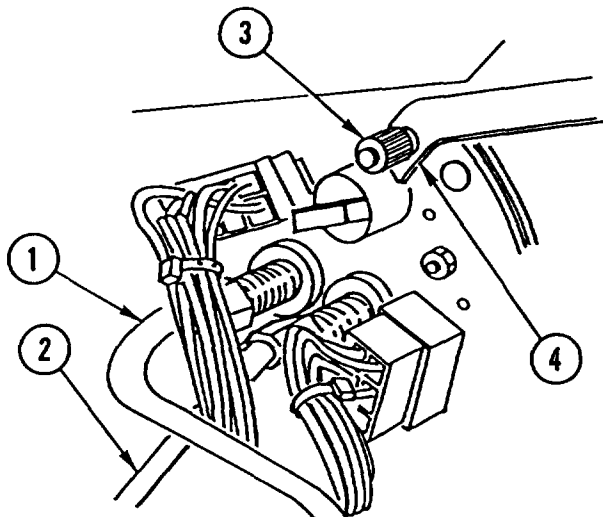

 INDICATOR (GAGE) REPLACEMENT (CONT)

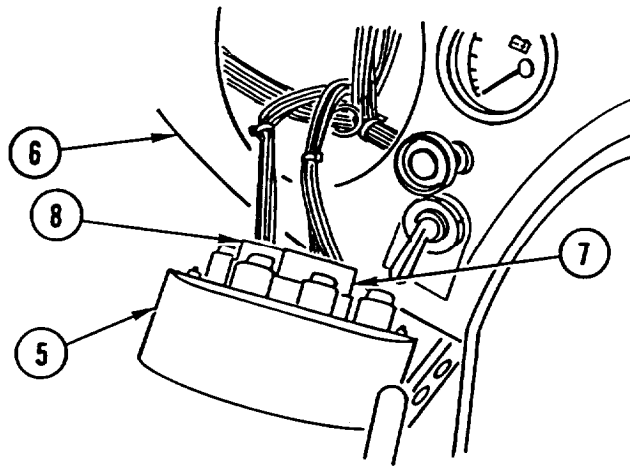

3. REMOVE INDICATOR (5) from dashboard (6).
4. DISCONNECT two CONNECTORS (7 and 8).

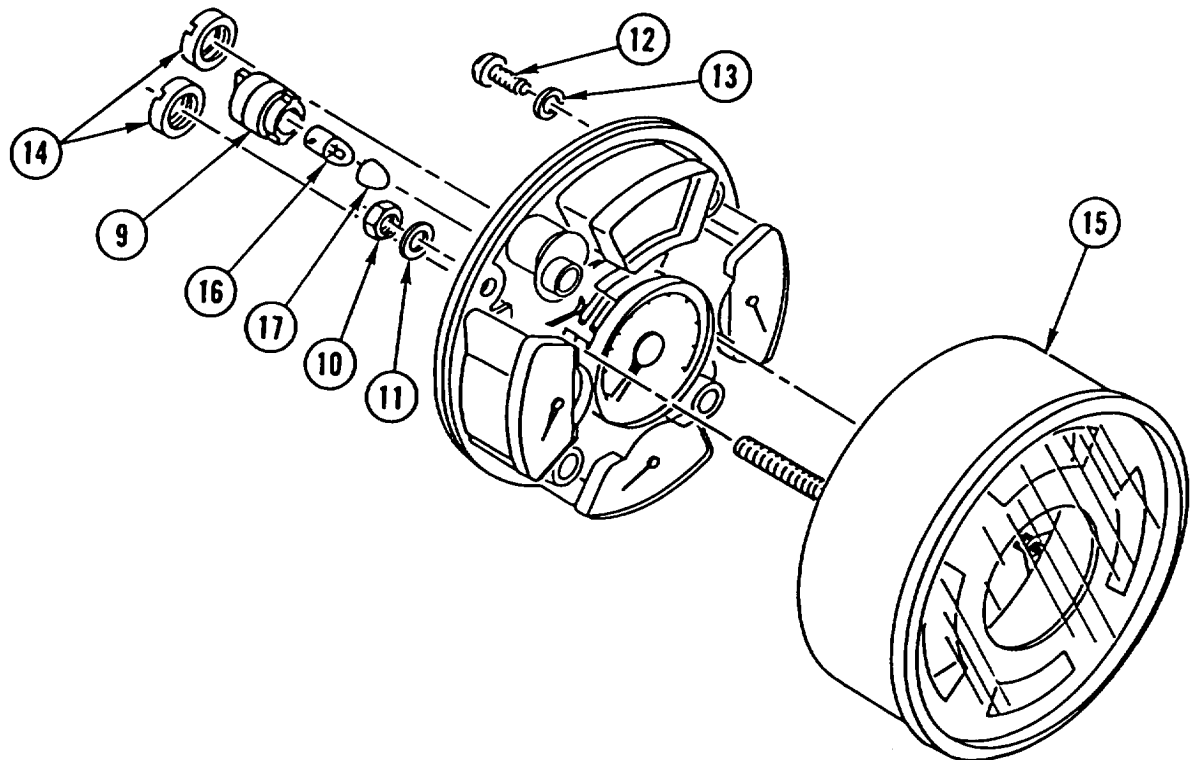

5. REMOVE seven lamp holders (9), five nuts (10), five washers (11), two screws (12), two lock washers (13), two nuts (14), and HOUSING (15). DISCARD lock WASHERS.
6. REMOVE LAMP (16) and FILTER (17) from each of seven lamp holders (9).

INDICATOR (GAGE) REPLACEMENT (CONT)

- REMOVE pressure GAGE (18), temperature INDICATOR (19), pressure GAGE (20), and liquid INDICATOR (21).

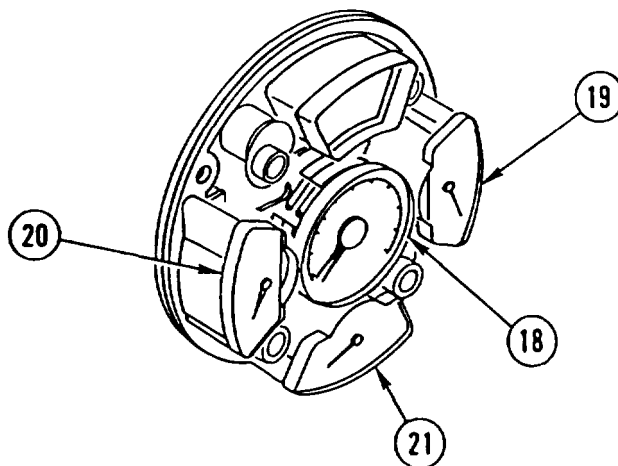

INSTALLATION

- INSTALL pressure GAGE (1), temperature INDICATOR (2), pressure GAGE (3), and liquid INDICATOR (4).

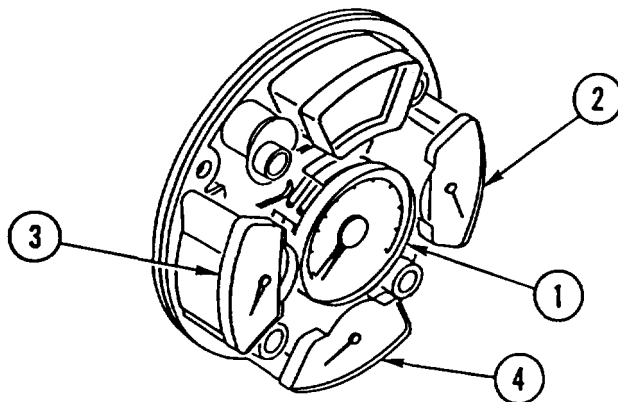

- INSTALL LAMP (5) and FILTER (6) in each of seven lamp holders (7).
- INSTALL HOUSING (8), two nuts (9), two new lock washers (10), two screws (11), five washers (12), five nuts (13), and seven lamp holders (7).

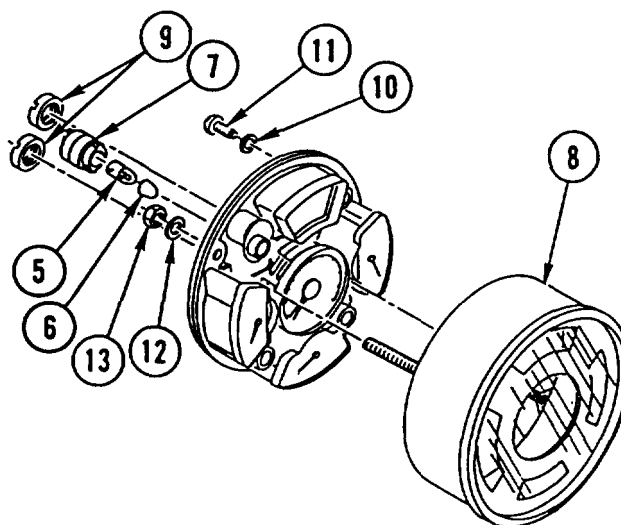

INDICATOR (GAGE) REPLACEMENT (CONT)

4. CONNECT two CONNECTORS (14 and 15).
5. INSTALL INDICATOR (16) in dashboard (17).

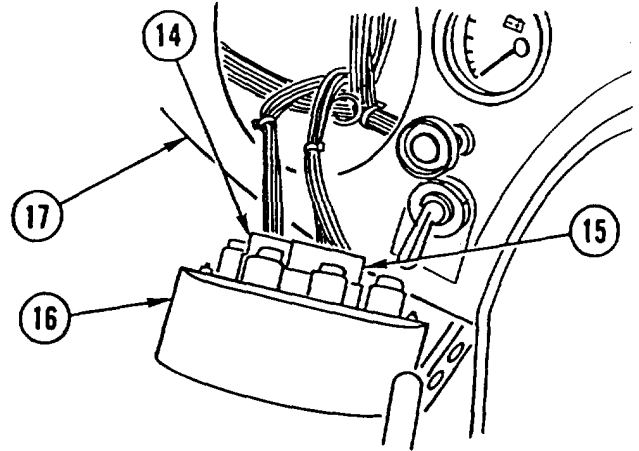

6. INSTALL two BRACKETS (18) and two nuts (19).
7. CONNECT two air HOSES (20 and 21).

NOTE

Follow-on Maintenance:
 Install fuse holders (page 4-166).
 Install outside engine hood (page 4-388).

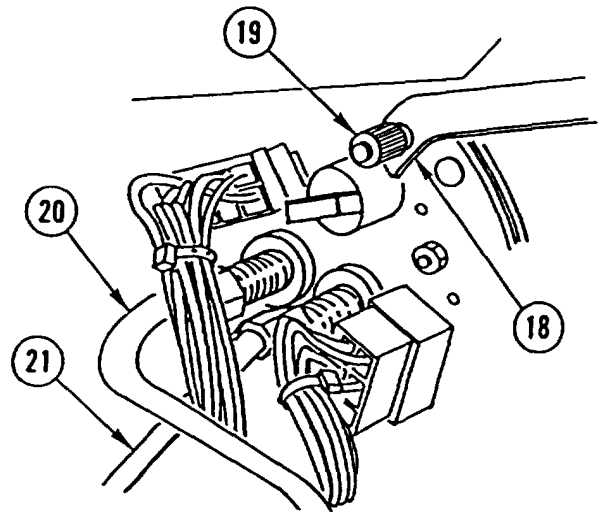

TACHOMETER REPLACEMENT

This task covers: a. Removal b. Installation

INITIAL SETUP

Tools and Special Equipment:

Tool Kit, SC5180-90-CL-N26

Equipment Condition:

Reference	Condition Description
Page 4-388	Outside Engine Hood Removed
Page 4-166	Fuse Holders Removed

General Safety Instructions:

WARNING

Remove or disconnect batteries and turn vehicle MASTER disconnect switch OFF prior to performing maintenance in immediate battery area or working on electrical system. Such disconnections prevent electrical shock to personnel or equipment.

REMOVAL

- 1 REMOVE two nuts (1) and two CLAMPS (2).

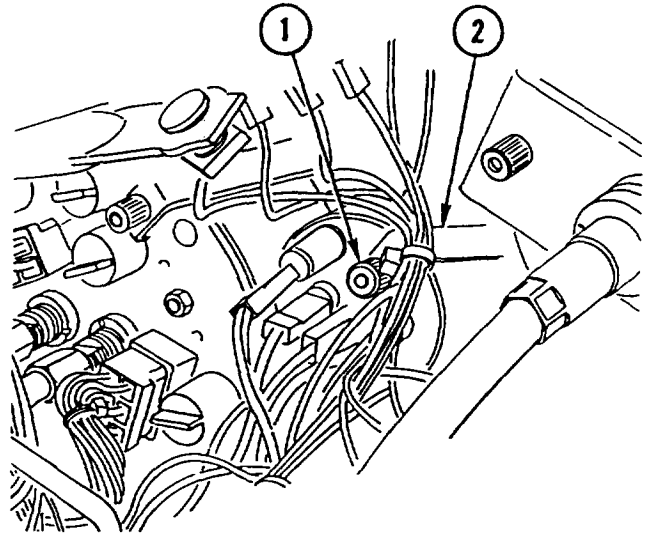

TACHOMETER REPLACEMENT (CONT)

NOTE

Tag wires prior to disconnecting to aid in connecting.

2. REMOVE TACHOMETER (3) from dashboard (4) and DISCONNECT four WIRES (5).

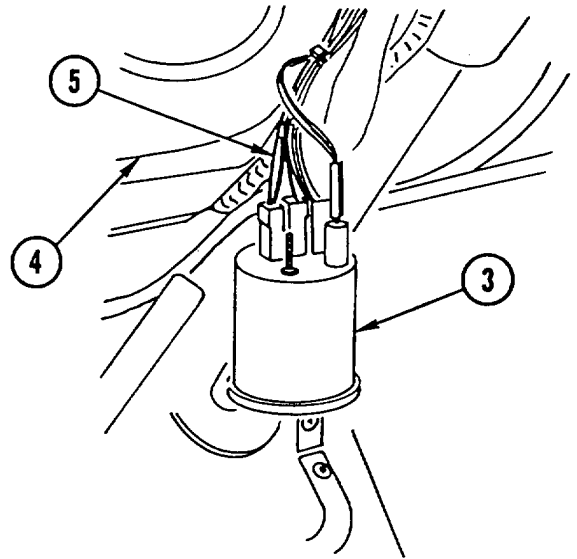

3. REMOVE lamp HOLDER (6).
4. REMOVE LAMP (7) and FILTER (8) from lamp holder (6).

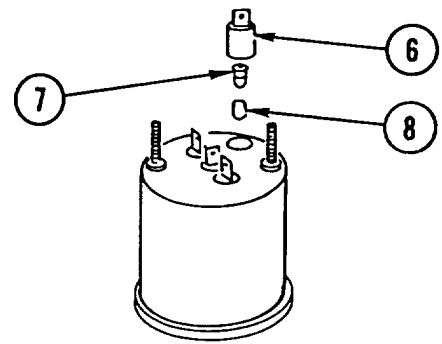

INSTALLATION

1. INSTALL LAMP (1) and FILTER (2) in lamp holder (3).
2. INSTALL lamp HOLDER (3).

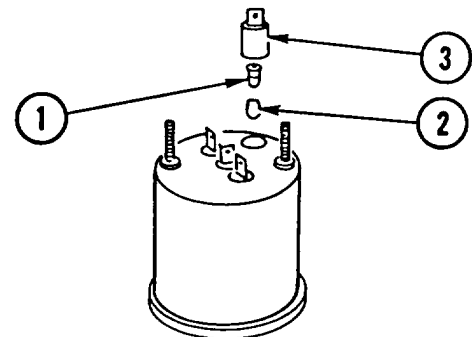

TACHOMETER REPLACEMENT (CONT)

3. CONNECT four WIRES (4) and INSTALL TACHOMETER (5) in dashboard (6).

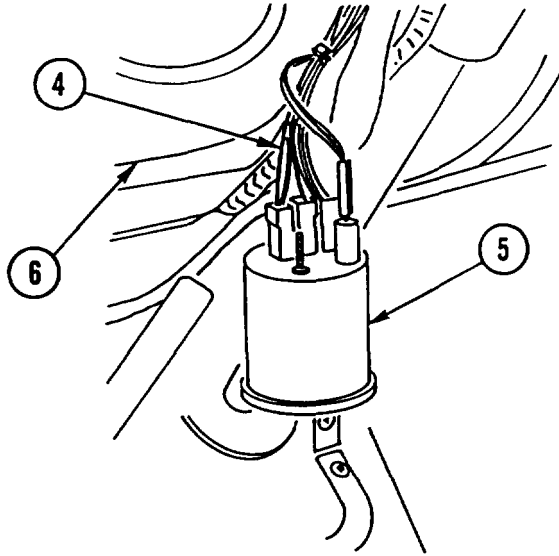

4. INSTALL two CLAMPS (7) and two nuts (8).

NOTE

Follow-on Maintenance:

Install fuse holders (page 4-166).
Install outside engine hood (page 4-388).

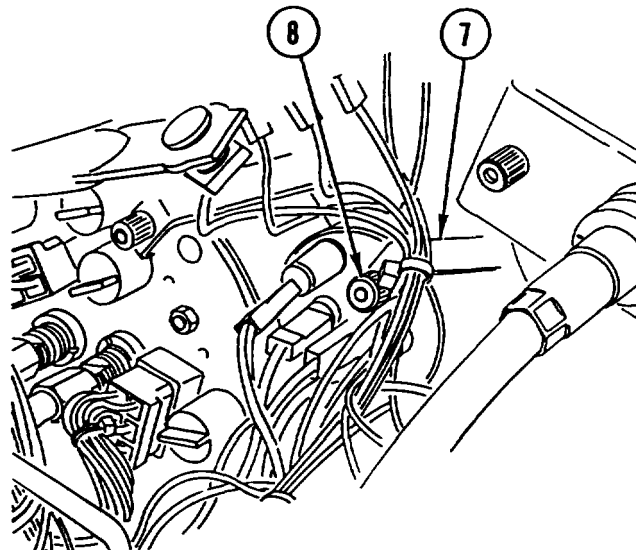

IGNITION SWITCH REPLACEMENT

This task covers: a. Removal b. Installation

INITIAL SETUP

Tools and Special Equipment:

Tool Kit, SC5180-90-CL-N26

Equipment Condition:

Reference	Condition Description
Page 4-388	Outside Engine Hood Removed

General Safety Instructions:

WARNING

Remove or disconnect batteries and turn vehicle MASTER disconnect switch OFF prior to performing maintenance in immediate battery area or working on electrical system. Such disconnections prevent electrical shock to personnel or equipment.

REMOVAL

1. REMOVE nut (1), washer (2), and ignition SWITCH (3) from dashboard (4).

NOTE

Tag wires prior to disconnecting to aid in connecting.

2. DISCONNECT eight WIRES (5) and REMOVE eight SCREWS (6) and eight washers (7) from switch (3).

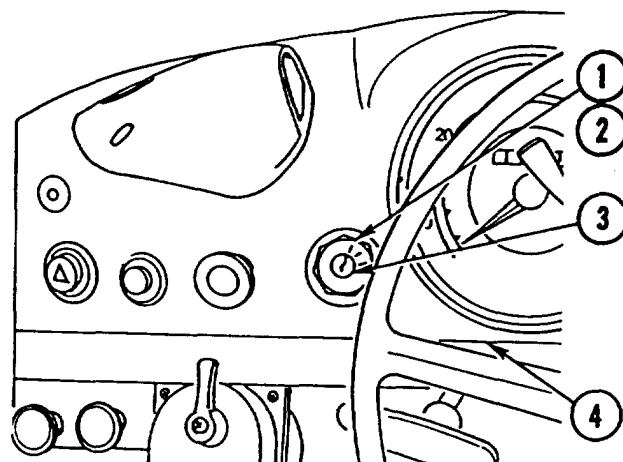

INSTALLATION

1. CONNECT eight WIRES (5) to ignition switch (3) and INSTALL eight washers (7) and eight SCREWS (6).
2. INSTALL SWITCH (3) in dashboard
3. INSTALL washer (2) and NUT (1).

NOTE

Follow-on Maintenance:
Install outside engine hood (page 4-388).

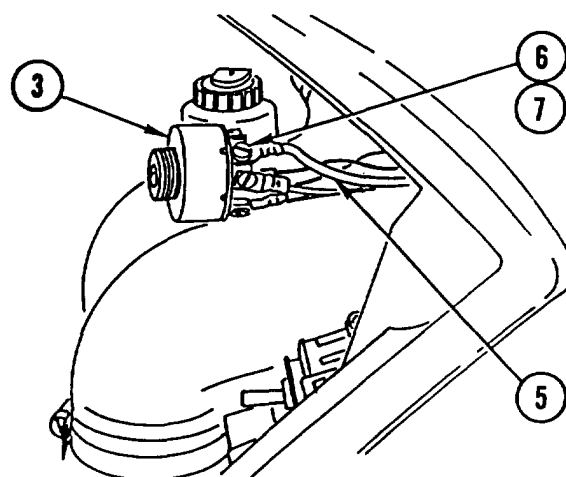

WINDSHIELD WIPER/WASHER SWITCH REPLACEMENT

This task covers: a. Removal b. Installation

INITIAL SETUP

Tools and Special Equipment:

Tool Kit, SC5180-90-CL-N26

Equipment Condition:

Reference	Condition Description
Page 4-486	Defroster and Air Tubes Removed

General Safety Instructions:

WARNING

Remove or disconnect batteries and turn vehicle MASTER disconnect switch OFF Drier to performing maintenance in immediate battery area or working on electrical system. Such disconnections prevent electrical shock to personnel or equipment.

REMOVAL

1. REMOVE KNOB (1) from windshield wiper/washer switch (2).
2. REMOVE nut (3) and SWITCH (2) from dashboard (4).

NOTE

Tag wires prior to disconnecting to aid in connecting.

3. DISCONNECT six WIRES (5) from switch (2).

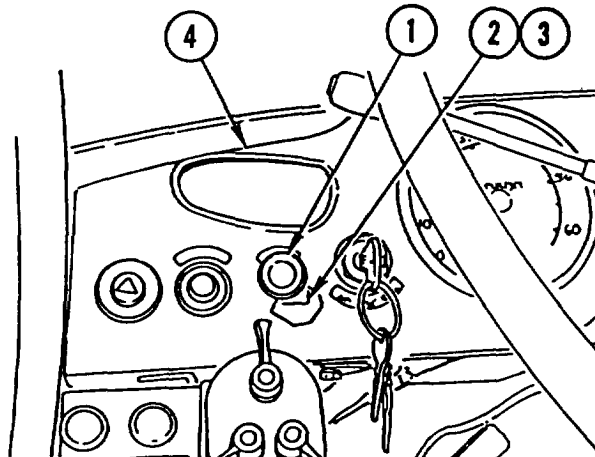

INSTALLATION

1. CONNECT six WIRES (5) to windshield wiper/washer switch (2).
2. INSTALL SWITCH (2) and nut (3) in dashboard (4).
3. INSTALL KNOB (1).

NOTE

Follow-on Maintenance:
Install defroster and air tubes (page 4-486).

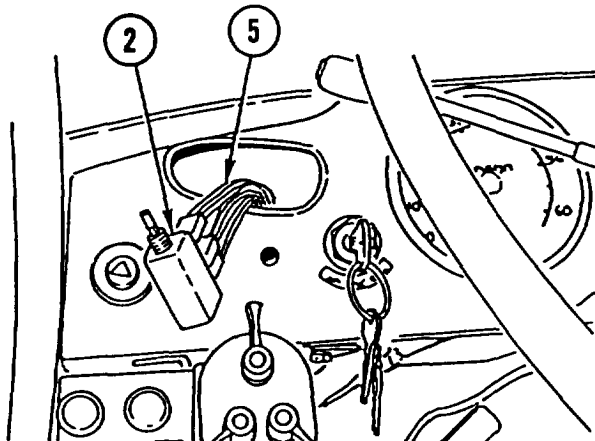

STARTER SWITCH REPLACEMENT

This task covers: a. Removal b. Installation

INITIAL SETUP

Tools and Special Equipment:

Tool Kit, SC 5180-90-CL-N26

Equipment Condition:

Reference	Condition Description
Page 4-166	Fuse Holders Removed
Page 4-486	Defroster and Air Tubes Removed

General Safety Instructions:

WARNING

Remove or disconnect batteries and turn vehicle MASTER disconnect switch OFF prior to performing maintenance in immediate battery area or working on electrical system. Such disconnections prevent electrical shock to personnel or equipment.

REMOVAL

NOTE

Tag wires prior to disconnecting to aid in connecting.

1. DISCONNECT two WIRES (1 and 2) from starter switch (3).
2. REMOVE NUT (4).
3. REMOVE SWITCH (3) from dashboard (5).

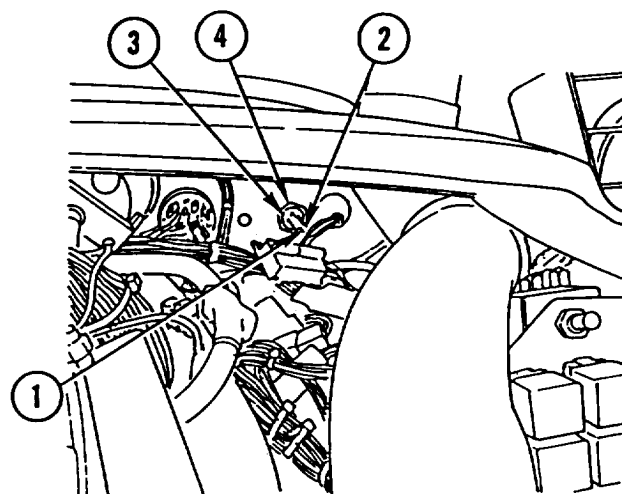

INSTALLATION

1. INSTALL starter SWITCH (3) in dashboard (5).
2. INSTALL NUT (4).
3. CONNECT two WIRES (1 and 2) to switch (3).

NOTE

Follow-on Maintenance:

Install defroster and air tubes (page 4-486).
Install fuse holders (page 4-166).

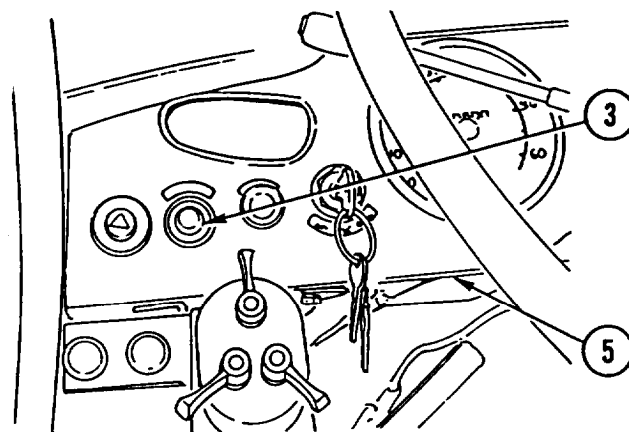

HAZARD WARNING SWITCH REPLACEMENT

This task covers: a. Removal b. Installation

INITIAL SETUP

Tools and Special Equipment:

Tool Kit, SC 5180-90-CL-N26

General Safety instructions:

WARNING

Remove or disconnect batteries and turn vehicle MASTER disconnect switch OFF prior to performing maintenance in immediate battery area or working on electrical system. Such disconnections prevent electrical shock to personnel or equipment.

REMOVAL

1. REMOVE hazard warning SWITCH (1) from dashboard (2).
2. Disconnect CONNECTOR (3).
3. REMOVE BUTTON (4) and LAMP (5) from switch (1).

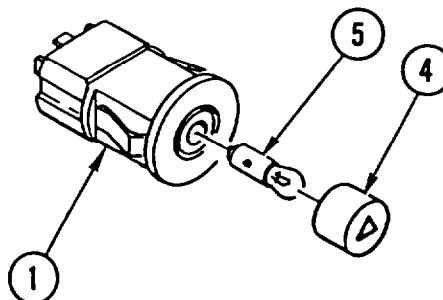
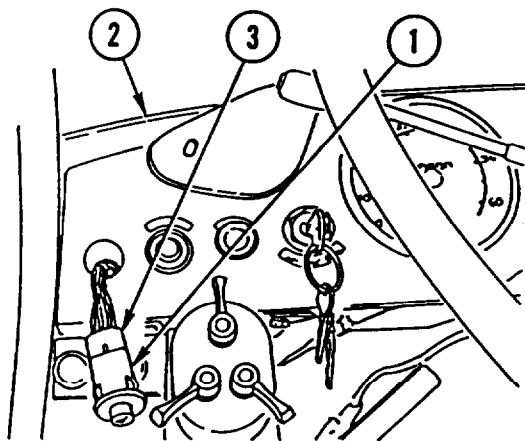

INSTALLATION

1. INSTALL LAMP (5) and BUTTON (4) in hazard warning switch (1).
2. CONNECT CONNECTOR (3).
3. INSTALL SWITCH (1) in dashboard (2).

VOLTMETER GAGE REPLACEMENT

This task covers: a. Removal b. Installation

INITIAL SETUP

Tools and Special Equipment:

Tool Kit, SC 5180-90-CL-N26

Equipment Condition:

Reference	Condition Description
Page 4-388	Outside Engine Hood Removed
Page 4-389	Inside Engine Hood Removed
Page 4-166	Fuse Holders Removed

REMOVAL

1. REMOVE two nuts (1) and REMOVE COVER (2).

NOTE

Tag wires prior to disconnecting to aid in connecting.

2. REMOVE voltmeter gage (3) from dashboard (4) and disconnect three WIRES.
3. REMOVE light SOCKET (6).
4. REMOVE LAMP (7) and FILTER (8) from light socket (6).

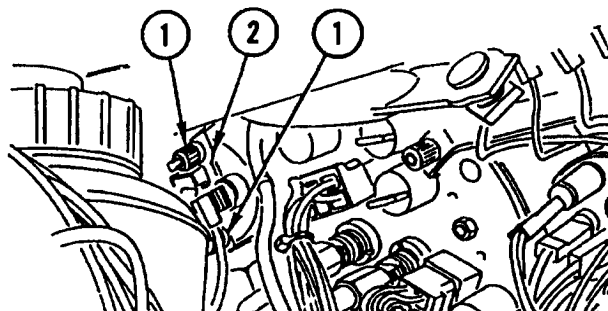

INSTALLATION

1. INSTALL LAMP (7) and FILTER (8) from light socket (6).
2. INSTALL light SOCKET (6).
3. CONNECT three WIRES (5) and INSTALL VOLTMETER GAGE (3) in dashboard (4).
4. INSTALL BRACKET (2) and two nuts (1).

NOTE

Follow-on Maintenance:
 Install fuse holders (page 4-166).
 Install inside engine hood (page 4-389).
 Install outside engine hood (page 4-388).

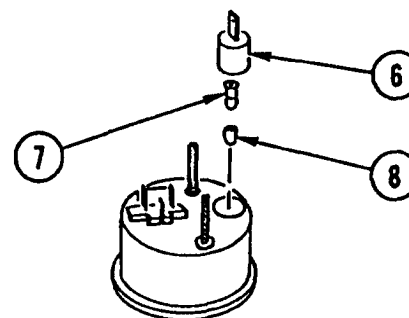
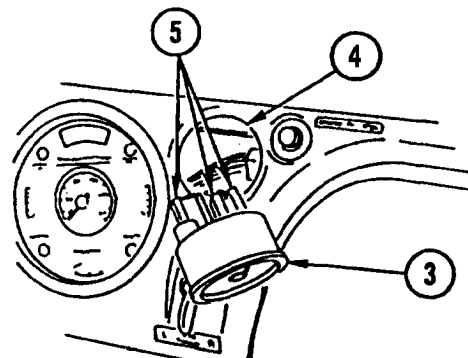

COLD START SWITCH REPLACEMENT

This task covers: a. Removal b. Installation

INITIAL SETUP

Tools and Special Equipment:

Tool Kit, SC 5180-90-CL-N26

Equipment Condition:

Reference	Condition Description
Page 4-389	Inside Engine Hood Removed

General Safety Instructions:

WARNING

Remove or disconnect batteries and turn vehicle MASTER disconnect switch OFF prior to performing maintenance in immediate battery area or working on electrical system. Such disconnections prevent electrical shock to personnel or equipment.

REMOVAL

1. REMOVE KNOB (1) from cold start switch (2).
2. REMOVE nut (3) and SWITCH (2) from dashboard (4).

NOTE

Tag wires prior to disconnecting to aid in connecting.

3. DISCONNECT four WIRES (5) from switch (2).

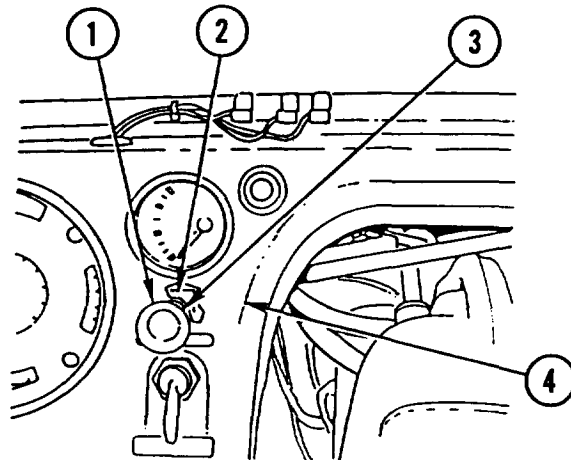

INSTALLATION

1. CONNECT four WIRES (5) to cold start switch (2).
2. INSTALL SWITCH (2) and nut (3) in dashboard (4).
3. INSTALL KNOB (1) on switch (2).

NOTE

Follow-on Maintenance:
Install inside engine hood (page 4-389).

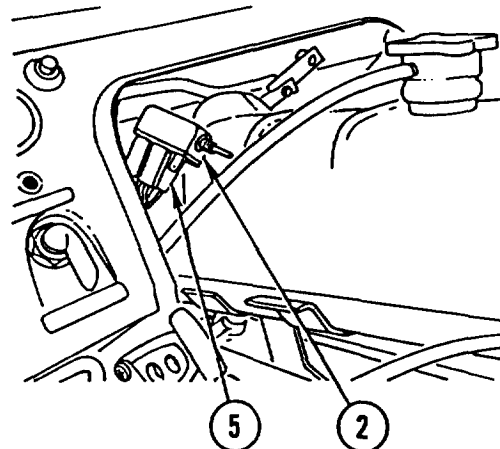

MASTER LIGHT SWITCH REPLACEMENT

This task covers: a. Removal b. Installation

INITIAL SETUP

Tools and Special Equipment:

Tool Kit, SC 5180-90-CL-N26

Equipment Condition:

Reference	Condition Description
Page 4-139	Windshield Heater Control Switches Removed

General Safety Instructions:

WARNING

Remove or disconnect batteries and turn vehicle MASTER disconnect switch OFF prior to performing maintenance in immediate battery area or working on electrical system. Such disconnections prevent electrical shock to personnel or equipment.

REMOVAL

1. DISCONNECT electrical PLUG (1) from master light switch (2).
2. REMOVE two capscrews (3), two washers (4), and BRACKET (5).
3. LOOSEN CAPSCREW (6) and REMOVE master light SWITCH (2) from bracket (5).

INSTALLATION

1. INSTALL master light SWITCH (2) in bracket (5) and TIGHTEN CAPSCREW (6).
2. INSTALL BRACKET (5), two washers (4), and two capscrews (3).
3. CONNECT electrical PLUG (1) to master light switch (2).

NOTE

Follow-on Maintenance:
Install windshield heater control switches (page 4-139).

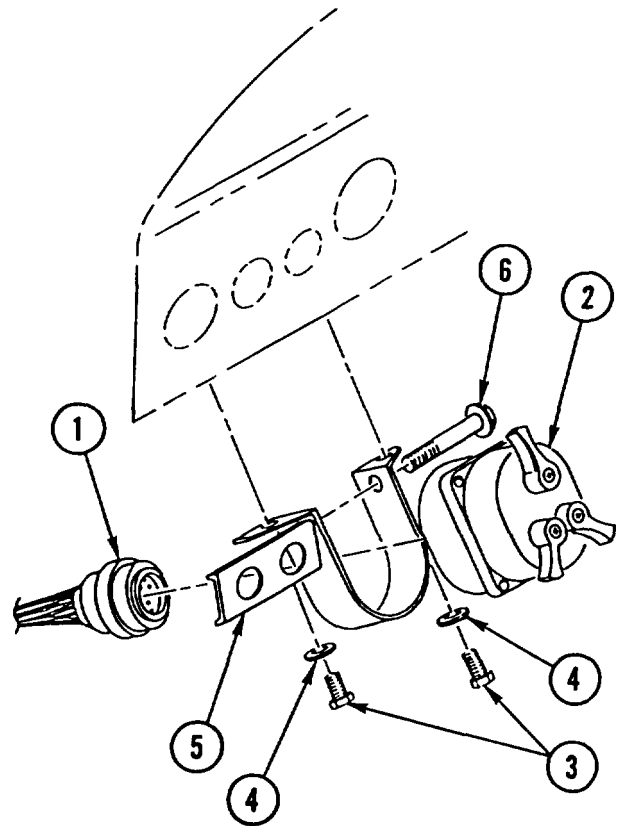

INSTRUMENT CLUSTER PANEL LIGHT REPLACEMENT

This task covers: a. Removal b. Installation

INITIAL SETUP

Tools and Special Equipment:

Tool Kit, SC 5180-90-CL-N26

General Safety Instructions:

WARNING

Remove or disconnect batteries and turn vehicle MASTER disconnect switch OFF prior to performing maintenance in immediate battery area or working on electrical system. Such disconnections prevent electrical shock to personnel or equipment.

REMOVAL

1. REMOVE LIGHT (1) from dashboard (2).

NOTE

Tag wires prior to disconnecting to aid in connecting.

2. DISCONNECT six WIRES (3) from light (1).
3. REMOVE five sign FACES (4) and five light SOCKETS (5).
4. REMOVE LAMP (6) from each socket (5).
5. REMOVE FILTER (7) from each lamp (6).

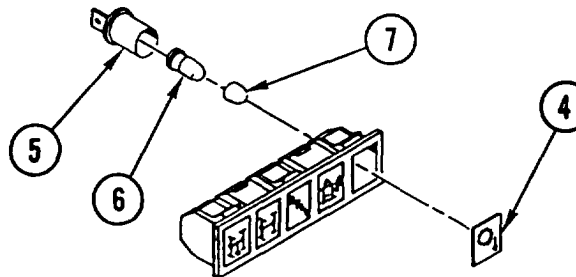
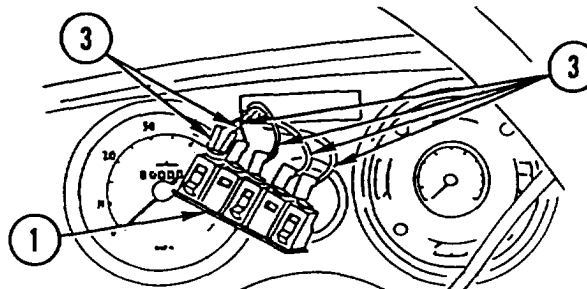
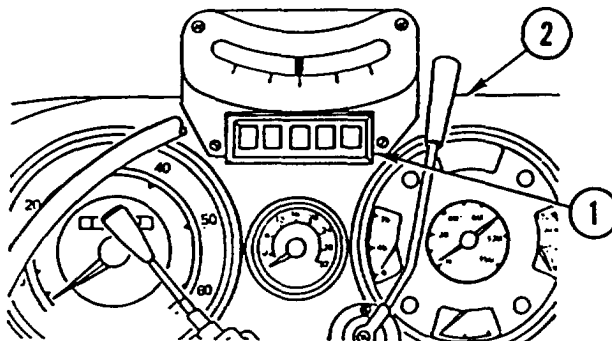

INSTALLATION

1. INSTALL FILTER (7) in each lamp (6).
2. INSTALL LAMP (6) in each socket (5).
3. INSTALL five light SOCKETS (5) and five sign FACES (4).
4. CONNECT six WIRES (3) to light (1).
5. INSTALL LIGHT (1) in dashboard (2).

WINDSHIELD HEATER CONTROL SWITCH REPLACEMENT

This task covers: a. Removal b. Installation

INITIAL SETUP

Tools and Special Equipment:

Tool Kit, SC 5180-90-CL-N26

General Safety Instructions:

WARNING

Remove or disconnect batteries and turn vehicle MASTER disconnect switch OFF prior to performing maintenance in immediate battery area or working on electrical system. Such disconnections prevent electrical shock to personnel or equipment.

NOTE

- Procedure is the same for both switches.
- Tag wires prior to disconnecting to aid in connecting.

1. DISCONNECT three WIRES (1, 2, and 3) from windshield heater control switch (4).
2. REMOVE SWITCH (5) from switch (4).
3. REMOVE nut (6) and SWITCH (4).
4. IF NECESSARY, REMOVE lens CAP (7) and LAMP (8) from switch (5).

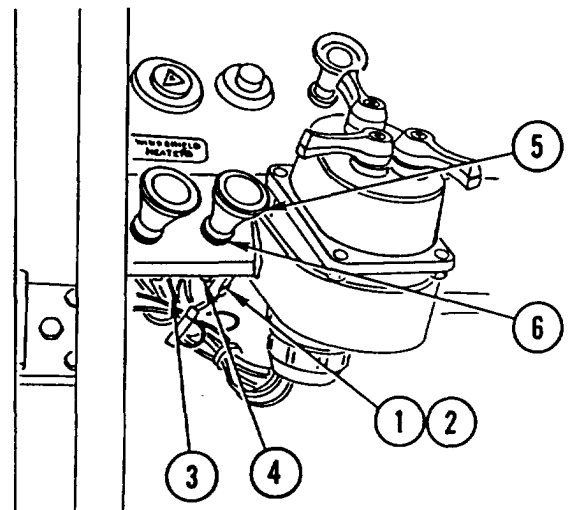

INSTALLATION

NOTE

Procedure is the same for both switches.

1. IF REMOVED, INSTALL new LAMP (8) and lens CAP (7) in switch (5).
2. INSTALL windshield heater control SWITCH (4) and nut (6).
3. INSTALL SWITCH (5) in switch (4).
4. CONNECT three WIRES (3, 2, and 1) to switch (4).

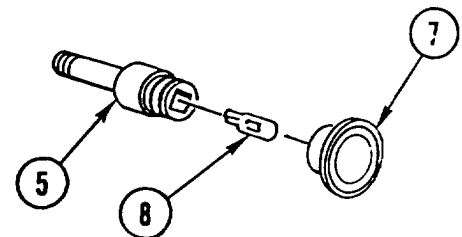

WINDSHIELD WIPER/WASHER SWITCH RELAY REPLACEMENT

This task covers: a. Removal b. Installation

INITIAL SETUP

Tools and Special Equipment:

Tool Kit, SC 5180-90-CL-N26

Equipment Condition:

Reference	Condition Description
Page 4-388	Outside Engine Hood Removed
Page 4-38	Air Cleaner Ducts Removed

REMOVAL

1. REMOVE screw (1), washer (2), and windshield wiper/washer switch RELAY (3).
2. DISCONNECT connector BODY (4) from windshield wiper/washer switch relay (3).

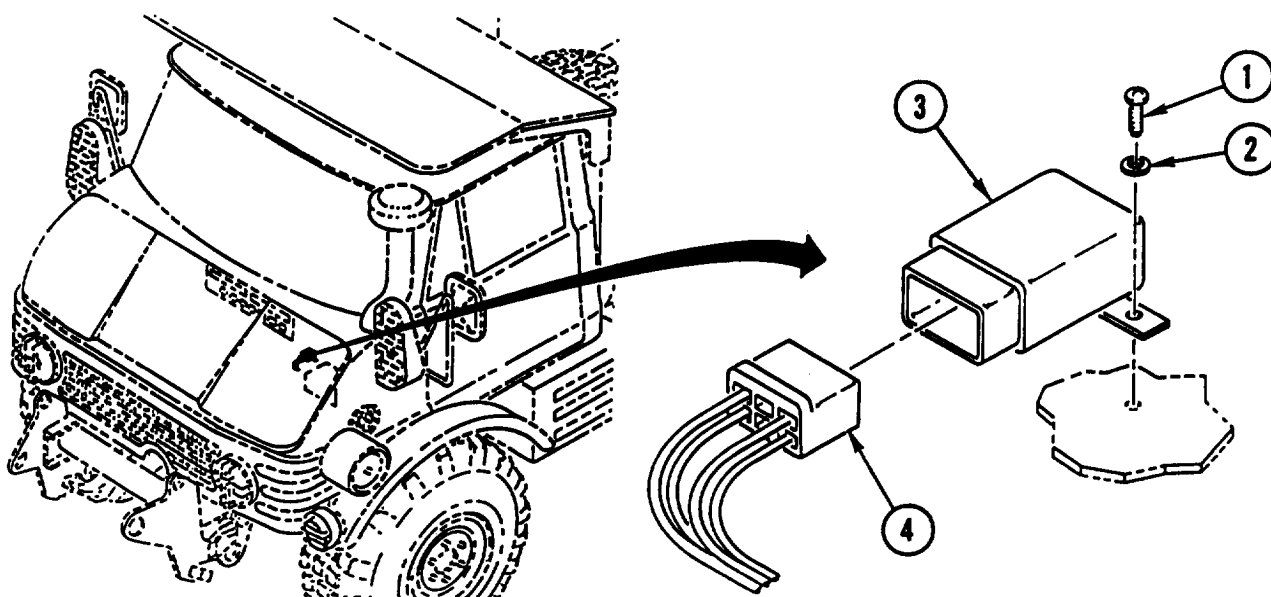

INSTALLATION

1. CONNECT connector BODY (4) to windshield wiper/washer switch relay (3).
2. INSTALL windshield wiper/washer switch RELAY (3), washer (2), and screw (1).

NOTE

Follow-on Maintenance:

Install air cleaner ducts (page 4-38).
 Install outside engine hood (page 4-388).

WARNING DELAY RELAY REPLACEMENT

This task covers: a. Removal b. Installation

INITIAL SETUP

Tools and Special Equipment:

Tool Kit, SC 5180-90-CL-N26

Materials/Parts:

Washer, Lock

Equipment Condition:

Reference

Page 4-388

Page 4-38

Condition Description

Outside Engine Hood
Removed

Air Cleaner Ducts
Removed

REMOVAL

1. REMOVE nut (1), lock washer (2), and warning delay RELAY (3). DISCARD lock WASHER.
2. DISCONNECT connector BODY (4) from warning delay relay (3).

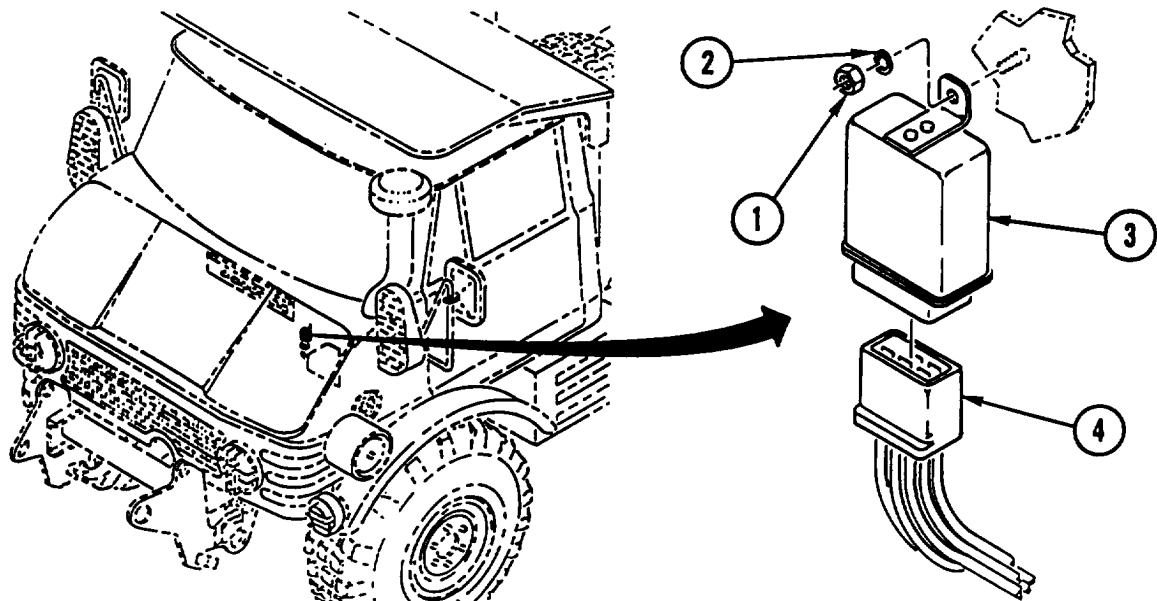

INSTALLATION

1. CONNECT connector BODY (4) to warning delay relay (3).
2. INSTALL warning delay RELAY (3), new lock washer (2), and nut (1).

NOTE

Follow-on Maintenance:

Install air cleaner ducts (page 4-38).
Install outside engine hood (page 4-388).

HYDRAULIC SUSPENSION LOCKOUT CONTROLS REPLACEMENT

This task covers: a. Removal b. Installation

INITIAL SETUP

Applicable Configuration:

HMMH

Tools and Special Equipment:

Tool Kit, SC 5180-90-CL-N26

Equipment Condition:

Reference	Condition Description
Page 4-446	Passenger Seat and Framework Removed

General Safety Instructions:

WARNING

Remove or disconnect batteries and turn vehicle MASTER disconnect switch OFF prior to performing maintenance in immediate battery area or working on electrical system. Such disconnections prevent electrical shock to personnel or equipment.

REMOVAL

NOTE

Tag all connector bodies prior to disconnecting to aid in connecting.

1. DISCONNECT CONNECTOR body (1) from light socket (2).
2. REMOVE nut (3), lens (4), washer (5), lamp (6), nut (7), washer (8), and light SOCKET (2) from mounting plate (9).
3. DISCONNECT CONNECTOR body (10) from rotary switch (11).
4. REMOVE knob (12), nut (13), and rotary SWITCH (11) from mounting plate (9).
5. PRY COVER (14) off fuse box (15).

NOTE

Tag leads prior to disconnecting to aid in connecting.

6. DISCONNECT two LEADS (16) from fuse box (15).
7. REMOVE two screws (17) and fuse BOX (15).
8. REMOVE RELAY(S) (18) by pulling straight up.
9. IF DAMAGED, REMOVE two screws (19), DISCONNECT relay plug HARNESS (20), and REMOVE four screws (21) and mounting PLATE (9).

**HYDRAULIC SUSPENSION LOCKOUT CONTROLS REPLACEMENT
(CONT)**

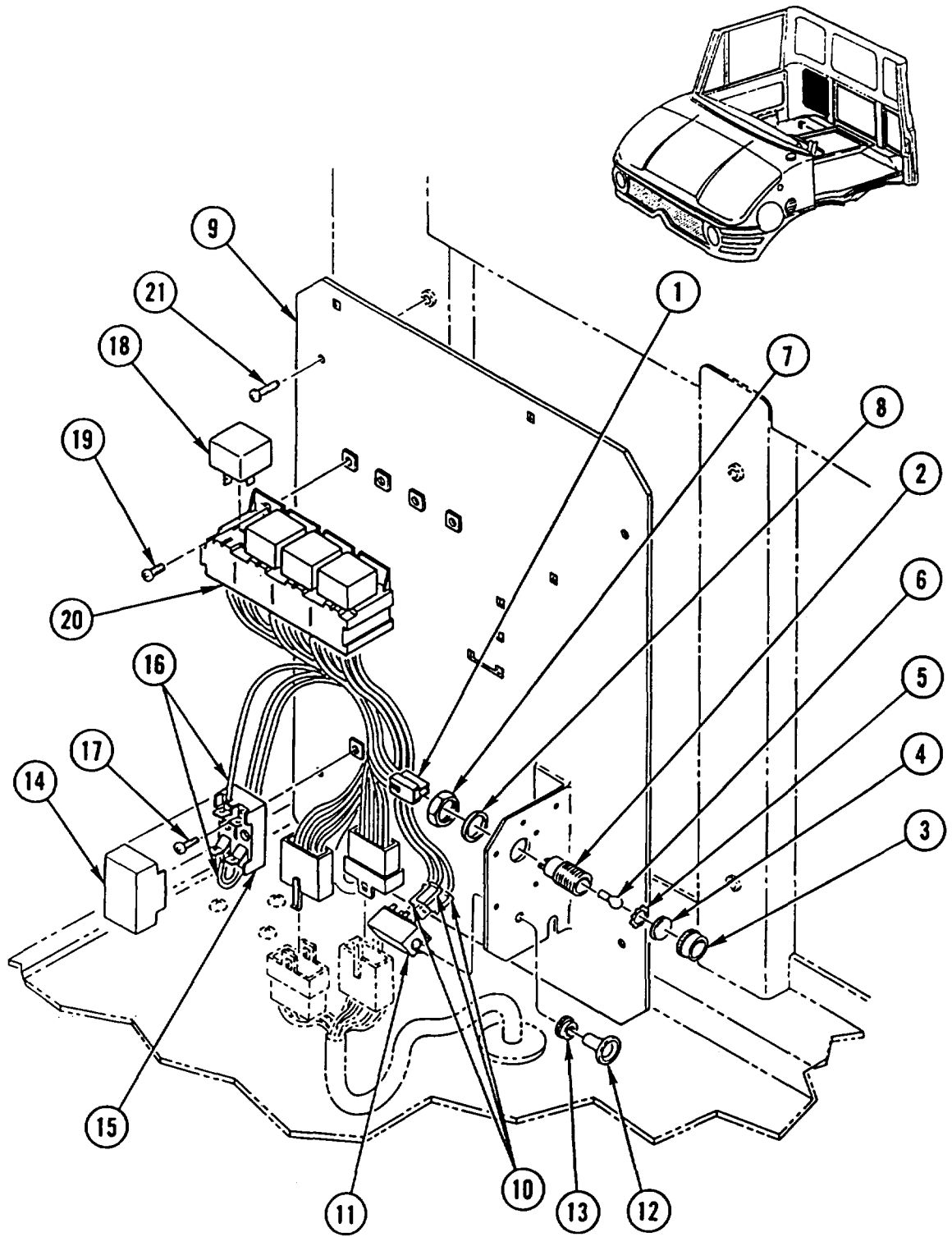

HYDRAULIC SUSPENSION LOCKOUT CONTROLS REPLACEMENT (CONT)

INSTALLATION

1. IF REMOVED, INSTALL new mounting PLATE (1) and four screws (2). CONNECT relay plug HARNESS (3) and INSTALL two SCREWS (4).
2. ALINE CONNECTORS and INSTALL RELAY(S) (5).
3. INSTALL fuse BOX (6) and two screws (7).
4. CONNECT two LEADS (8) to fuse box (6).
5. INSTALL COVER (9) on fuse box (6).
6. INSTALL rotary SWITCH (10), nut (11), and knob (12).
7. CONNECT CONNECTOR body (13) to rotary switch (10).
8. INSTALL washer (14), nut (15), and light SOCKET (16) on mounting plate (1).
9. INSTALL LAMP (17), washer (18), lens (19), and nut (20) on light socket (16).
10. CONNECT CONNECTOR body (21) to light socket (16).

NOTE

Follow-on Maintenance:
Install passenger seat and framework (page 4-446).

**HYDRAULIC SUSPENSION LOCKOUT CONTROLS REPLACEMENT
(CONT)**

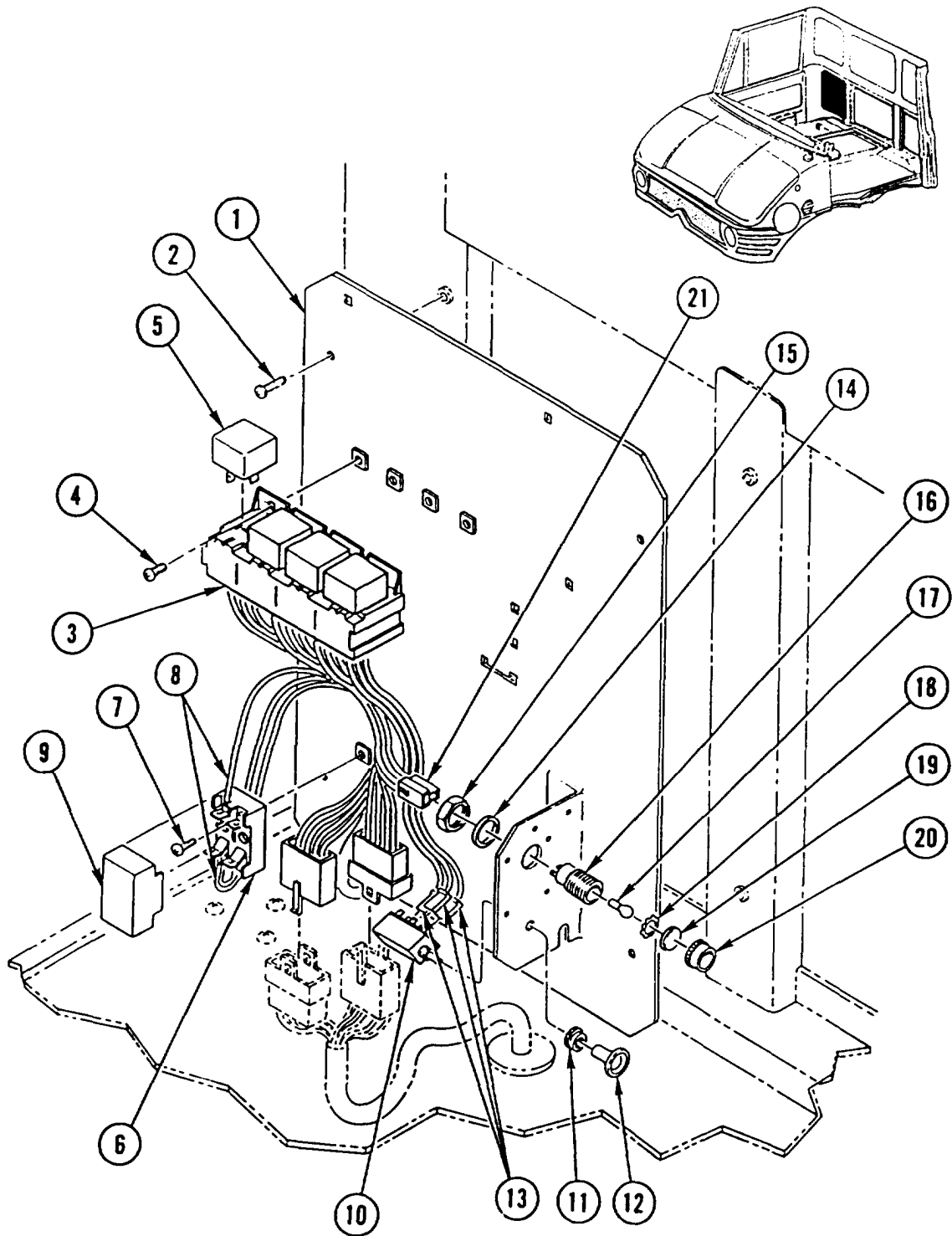

AUXILIARY LIGHT CONTROL SWITCH REPLACEMENT

This task covers: a. Removal b. Installation

INITIAL SETUP

Tools and Special Equipment:

Tool Kit, SC 5180-90-CL-N26

Equipment Condition:

Reference	Condition Description
Page 4-388	Outside Engine Hood Removed

General Safety Instructions:

WARNING

Remove or disconnect batteries and turn vehicle MASTER disconnect switch OFF prior to performing maintenance in immediate battery area or working on electrical system. Such disconnections prevent electrical shock to personnel or equipment.

REMOVAL

1. REMOVE nut (1) and light control SWITCH (2) from panel (3).
2. REMOVE washer (4) and NUT (5) from switch (2).

NOTE

Tag wires prior to disconnecting to aid in connecting.

3. DISCONNECT 12 WIRES (6) and REMOVE 12 SCREWS (7) and 12 washers (8).

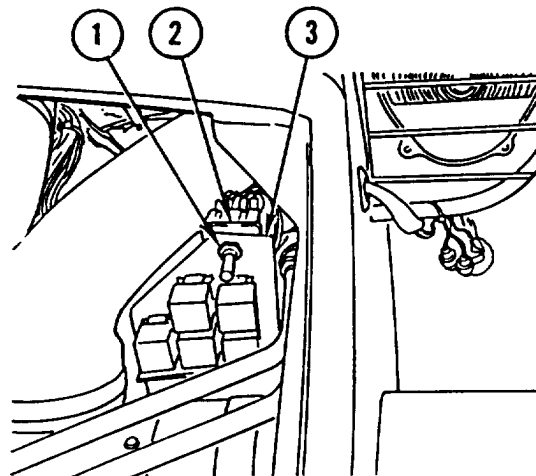

INSTALLATION

1. CONNECT 12 WIRES (6) and INSTALL 12 SCREWS (7) and 12 washers (8).
2. INSTALL NUT (5) and washer (4) on light control switch (2).
3. INSTALL SWITCH (2) in panel (3).
4. INSTALL NUT (1).

NOTE

Follow-on Maintenance:
Install outside engine hood (page 4-388).

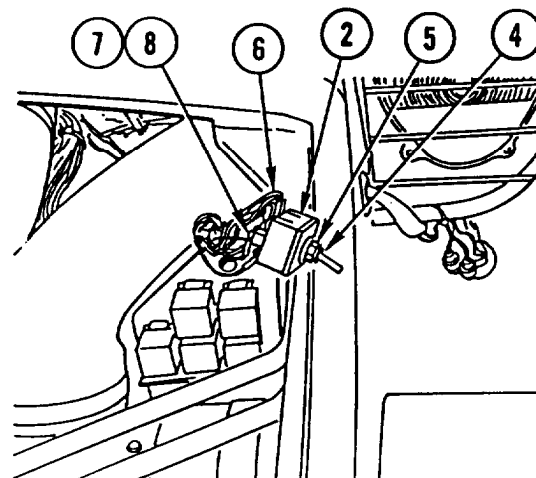

HYDRAULIC OIL COOLER THERMAL SWITCH REPLACEMENT

This task covers: a. Removal b. Testing c. Installation

INITIAL SETUP

Tools and Special Equipment:

Tool Kit, SC 5180-90-CL-N26
Shop Equipment, SC 4910-95-CL-A74

Materials/Parts:

Rags Appendix C, item 32

Equipment Condition:

Reference	Condition Description
Page 2-23	Hydraulic Pressure Relieved

General Safety Instructions:

WARNING

- High pressure hydraulics [oil under 2450 psi (16,893 kPa)] operate this equipment. Never disconnect any hydraulic line or fitting without first dropping pressure to zero. A high pressure oil stream can pierce body and cause severe injury to personnel.
- Removal or disconnect batteries and turn vehicle MASTER disconnect switch OFF prior to performing maintenance in immediate battery area or working on electrical system. Such disconnections prevent electrical shock to personnel or equipment.
- Fuel and oil are slippery and can cause falls. To avoid injury, wipe up spilled fuel or oil with rags.

REMOVAL

1. REMOVE two screws (1 and 2), washer (3), and GUARD (4).

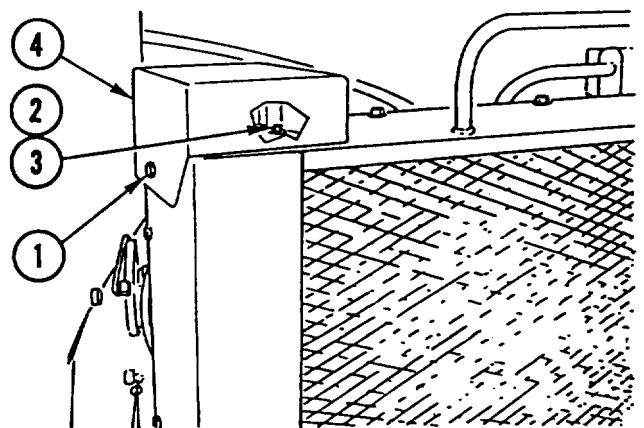

HYDRAULIC OIL COOLER THERMAL SWITCH REPLACEMENT (CONT)

NOTE

Tag all wires prior to disconnecting to aid in connecting.

2. REMOVE two SCREWS (5) and DISCONNECT two WIRES (6 and 7).
3. REMOVE SWITCH (8).

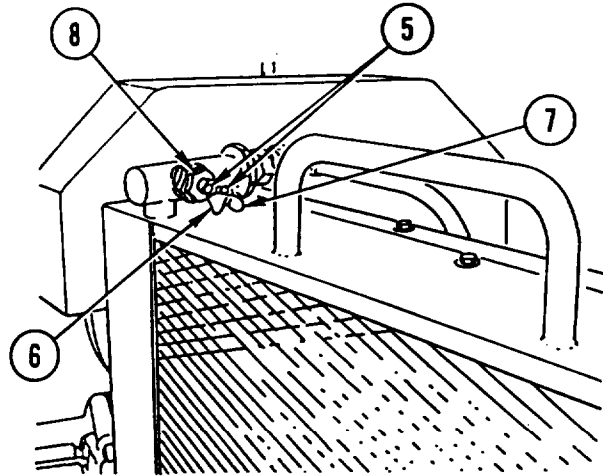

NOTE

If lower switch is to be replaced, hydraulic oil cooler must be removed from vehicle (page 4-722).

4. REMOVE two SCREWS (9) and DISCONNECT four WIRES (10, 11, 12, and 13).
5. REMOVE SWITCH (14).

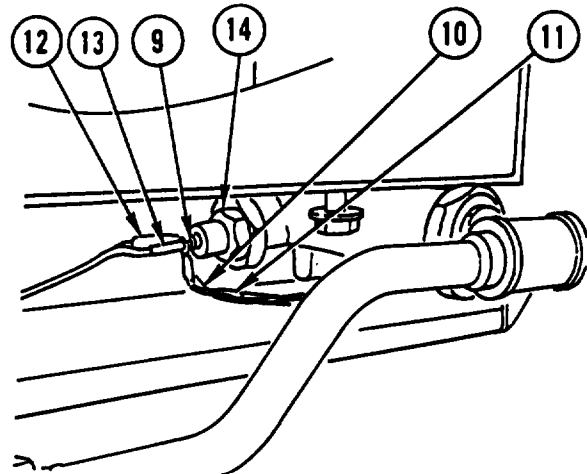

NOTE

Procedure is the same for both switches.

1. Check switch terminals (1 and 2) with multimeter set for continuity reading.
2. Multimeter reading should be open. If reading is closed, replace switch.
3. Insert switch in water heated to 130°-150°F (54.4° -65.5°F) for 30 seconds.
4. Remove switch from water and repeat step 1.
5. Multimeter reading should be closed. If reading is open, replace switch.

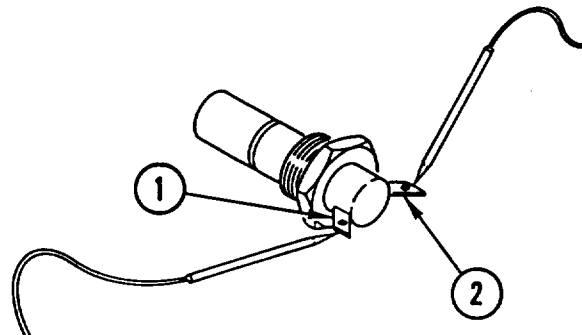

HYDRAULIC OIL COOLER THERMAL SWITCH REPLACEMENT (CONT)

INSTALLATION

1. INSTALL SWITCH (1).
2. CONNECT four WIRES (2, 3, 4, and 5) and INSTALL two SCREWS (6).

3. INSTALL SWITCH (7).
4. CONNECT two WIRES (8 and 9) and INSTALL two SCREWS (10).

5. INSTALL GUARD (11), washer (12), and screws (13 and 14).

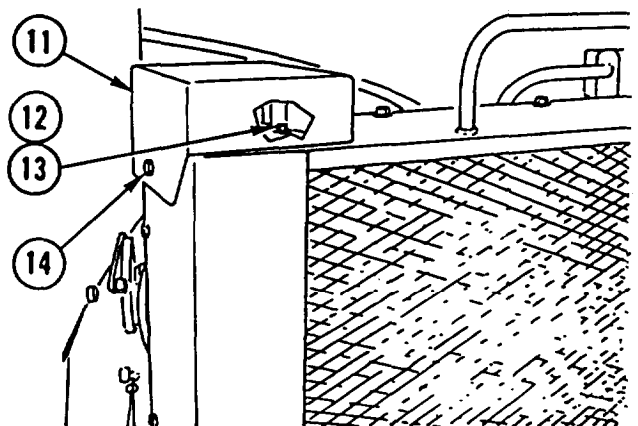
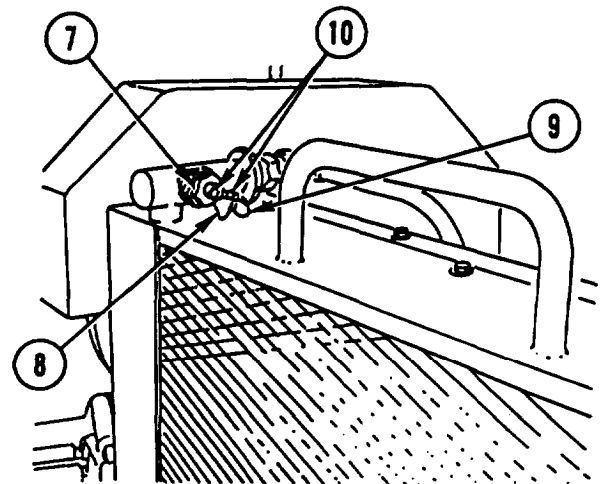
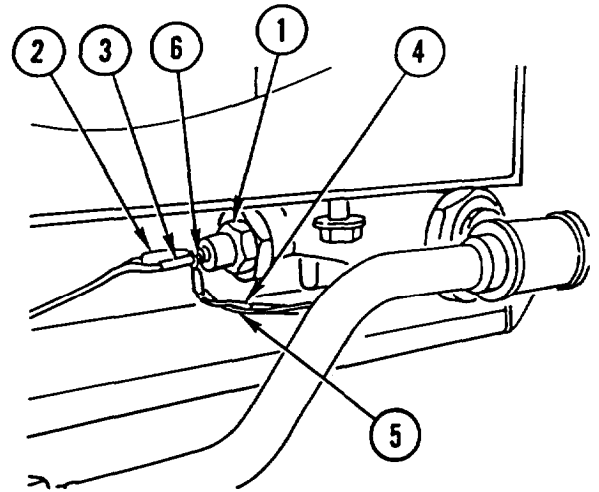

RELAY REPLACEMENT

This task covers: a. Removal b. Installation

INITIAL SETUP

Tools and Special Equipment:

Tool Kit, SC 5180-90-CL-N26

Equipment Condition:

Reference	Condition Description:
Page 4-388	Outside Engine Hood Removed

General Safety Instructions:

WARNING

Remove or disconnect batteries and turn vehicle MASTER disconnect switch OFF prior to performing maintenance in immediate battery area or working on electrical system. Such disconnections prevent electrical shock to personnel or equipment.

REMOVAL

USING CHART, REMOVE RELAY (K1, K2, K3, K4, or K5) by pulling straight out.

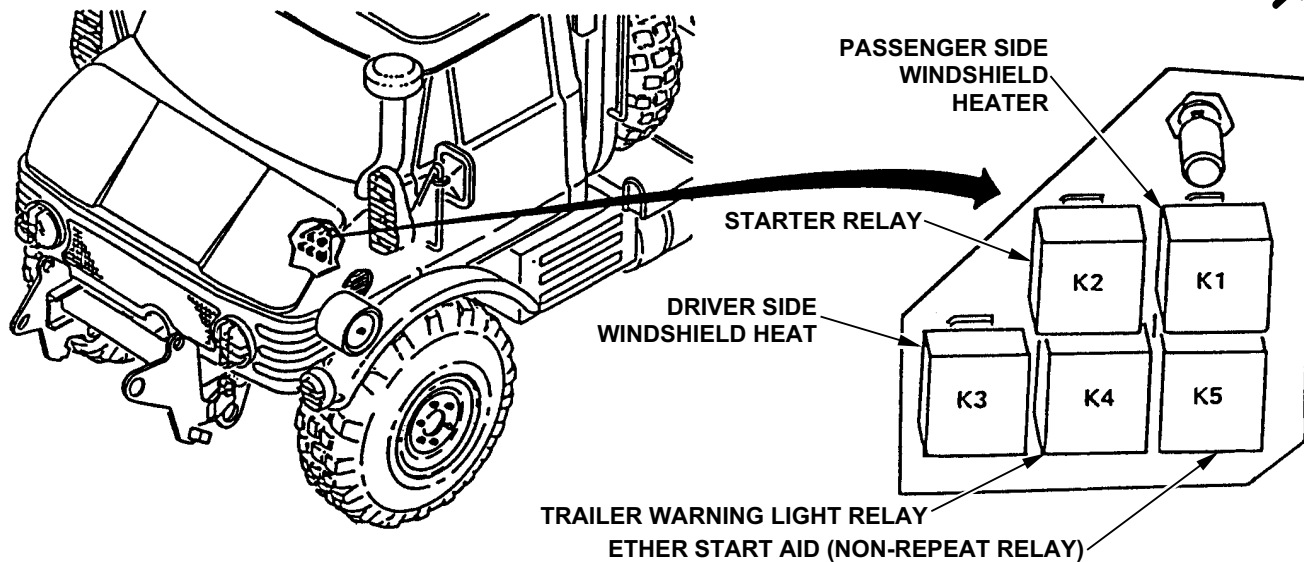

INSTALLATION

ALINE CONNECTORS and INSTALL new RELAY (K1, K2, K3, K4, or K5).

NOTE

Follow-on Maintenance:

Install outside engine hood (page 4-388).

BUCKET AND AUXILIARY THROTTLE SWITCHES REPLACEMENT

This task covers: a. Removal b. Installation

INITIAL SETUP**Applicable Configuration:**

SEE

Tools and Special Equipment:

Tool Kit, SC 5180-90-CL-N26

General Safety Instructions:**WARNING**

Remove or disconnect batteries and turn vehicle MASTER disconnect switch OFF prior to performing maintenance in immediate battery area or working on electrical system. Such disconnections prevent electrical shock to personnel or equipment.

REMOVAL

1. REMOVE five screws (1) and control TOWER (2).

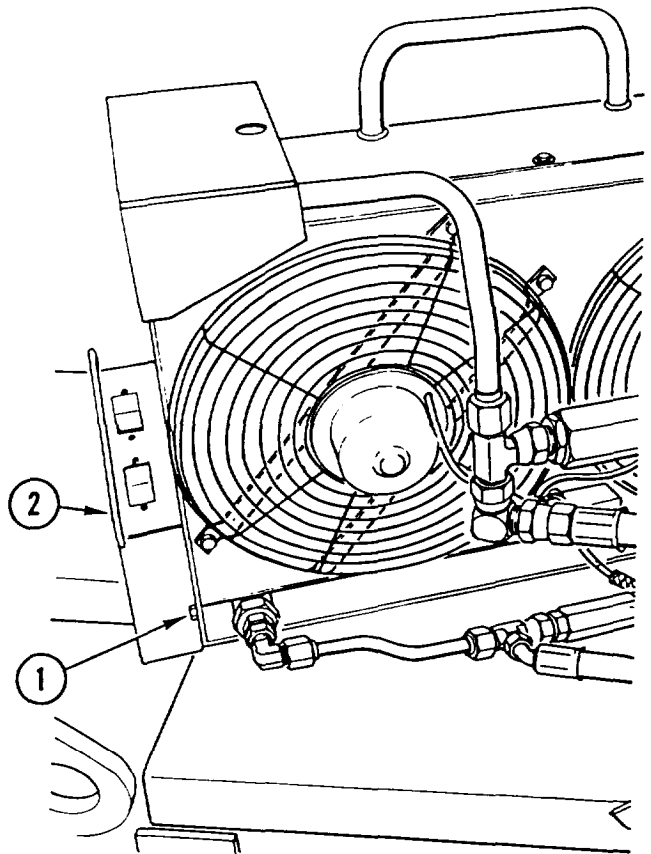

BUCKET AND AUXILIARY THROTTLE SWITCHES REPLACEMENT (CONT)

NOTE

Tag all wires prior to disconnecting to aid in connecting.

2. DISCONNECT three WIRES (3) from switch (4).
3. DISCONNECT two WIRES (5) from switch (6).
4. REMOVE two screws (7) and SWITCH (4).
5. REMOVE two screws (8) and SWITCH (6).
6. CAREFULLY ROLL BACK rubber COVERS (9) and DISCONNECT two WIRES (10).
7. REMOVE two screws (11), two nuts (12), and low oil pressure ALARM (13).

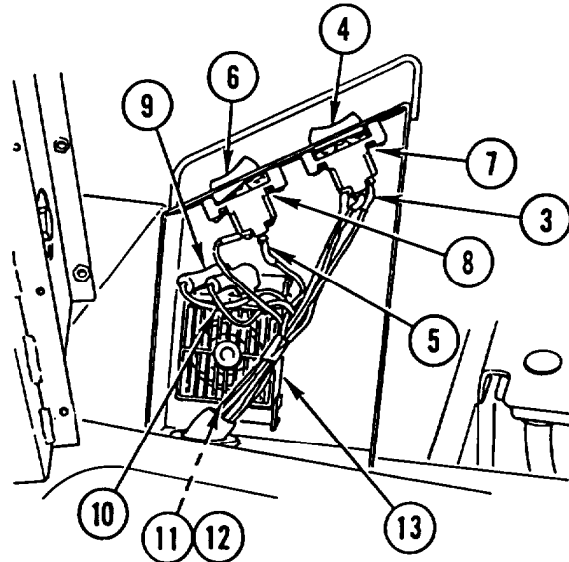

INSTALLATION

1. INSTALL low oil pressure ALARM (1), two screws (2), and two nuts (3).
2. CONNECT two WIRES (4) and CAREFULLY ROLL rubber COVERS (5) BACK in place.
3. INSTALL SWITCH (6) and two screws (7).
4. INSTALL SWITCH (8) and two screws (9).
5. CONNECT two WIRES (10) to switch (6).
6. CONNECT three WIRES (11) to switch (8).

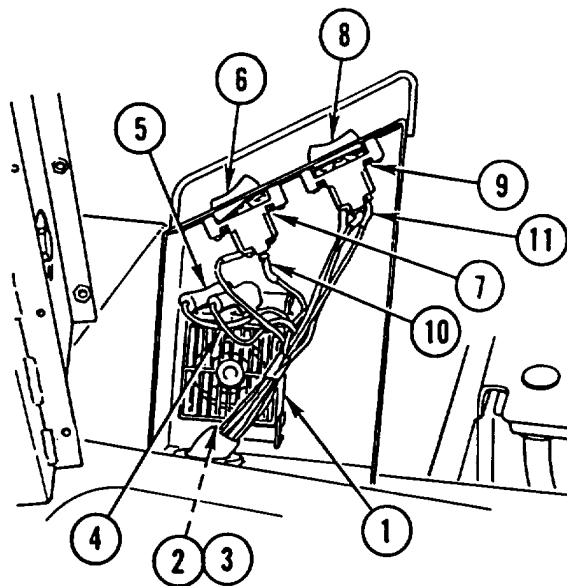

BUCKET AND AUXILIARY THROTTLE SWITCHES REPLACEMENT
(CONT)

7. INSTALL control TOWER (12) and five screws (13).

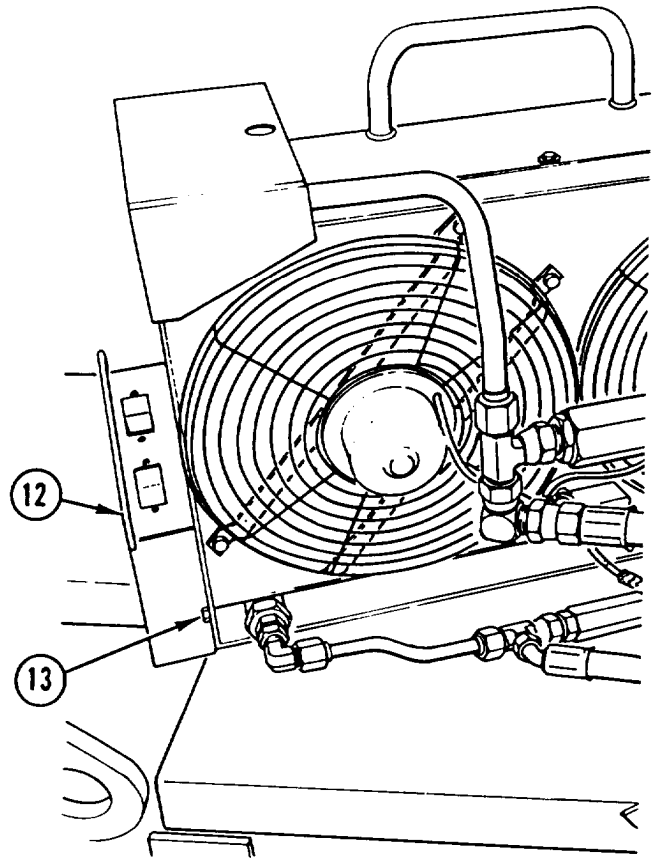

THROTTLE CONTROL SWITCH REPLACEMENT

This task covers: a. Removal b. Installation

INITIAL SETUP

Applicable Configuration:

SEE

Tools and Special Equipment:

Tool Kit, SC 5180-90-CL-N26

Materials/Parts:

Washer, Lock (2)

Equipment Condition:

Reference

Page 2-24

Page 2-23

Condition Description

Batteries Disconnected

Air Pressure Relieved

General Safety Instructions:

WARNING

Do not disconnect any air system lines or fittings unless vehicle engine is shut off and air system pressure is relieved. To do so could result in injury to personnel.

REMOVAL

1. REMOVE seven SCREWS (1) and seven washers (2) from cabinet assembly (3).

NOTE

Tag all wires and lines prior to disconnecting to aid in connecting.

2. DISCONNECT WIRE (4) from throttle switch (5) and SET CABINET assembly (3) ASIDE.
3. DISCONNECT ground WIRE (6) from throttle switch (5).
4. DISCONNECT two air TUBES (7 and 8) from throttle switch (5).
5. REMOVE two screws (9), two lock washers (10), ground WIRE (6), and throttle SWITCH (5) from bracket (11). DISCARD lock WASHERS.
6. REMOVE nut (12), screw (13), and BRACKET (11) from platform (14).
7. REMOVE two ELBOWS (15 and 16) from throttle switch (5).

THROTTLE CONTROL SWITCH REPLACEMENT (CONT)

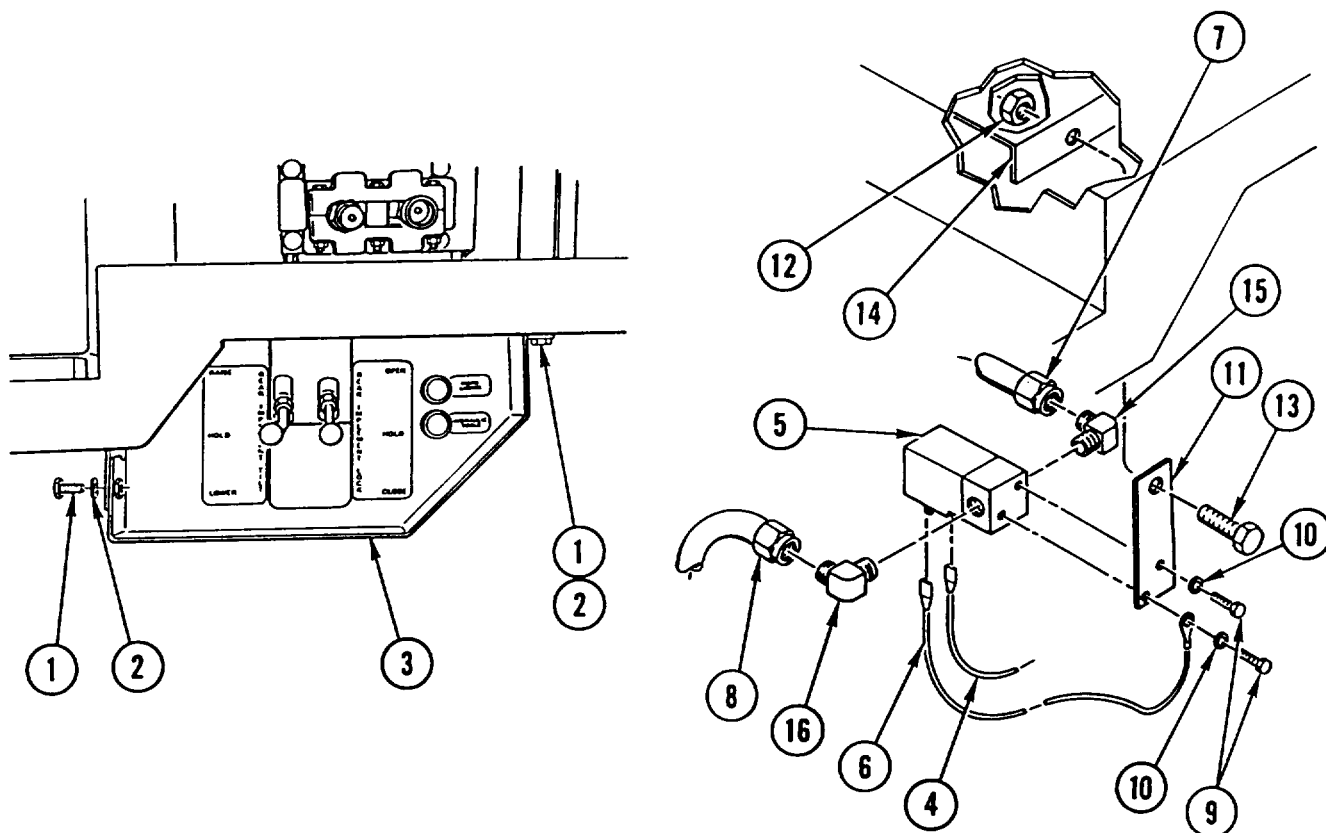
INSTALLATION

1. INSTALL two ELBOWS (16 and 15) on throttle switch (5).
2. INSTALL BRACKET (11), screw (13), and nut (12) on platform (14).
3. INSTALL throttle SWITCH (5), ground WIRE (6), two new lock washers (10), and two screws (9) on bracket (11).
4. CONNECT two air TUBES (8 and 7) to throttle switch (5).
5. CONNECT ground WIRE (6) to throttle switch (5).
6. CONNECT WIRE (4) to throttle switch (5).
7. INSTALL CABINET assembly (3), seven washers (2), and seven screws (1).

NOTE

Follow-on Maintenance:

Connect batteries (page 2-24).

AUXILIARY THROTTLE SWITCH REPLACEMENT

This task covers: a. Removal b. Installation

INITIAL SETUP

Applicable Configuration:

HMMH

Tools and Special Equipment:

Tool Kit, SC 5180-90-CL-N26

General Safety Instructions:

WARNING

Remove or disconnect batteries and turn vehicle MASTER disconnect switch OFF prior to performing maintenance in immediate battery area or working on electrical system. Such disconnections prevent electrical shock to personnel or equipment.

REMOVAL

1. REMOVE five screws (1) and control TOWER (2).
2. REMOVE two screws (3) and RPM SWITCH (4).

NOTE

Tag all wires prior to removal to aid in installation.

3. REMOVE two WIRES (5) from RPM SWITCH (4).
4. CAREFULLY ROLL BACK rubber COVERS (6) and REMOVE two WIRES (7), two screws (8), and low oil pressure ALARM (9).

AUXILIARY THROTTLE SWITCH REPLACEMENT (CONT)

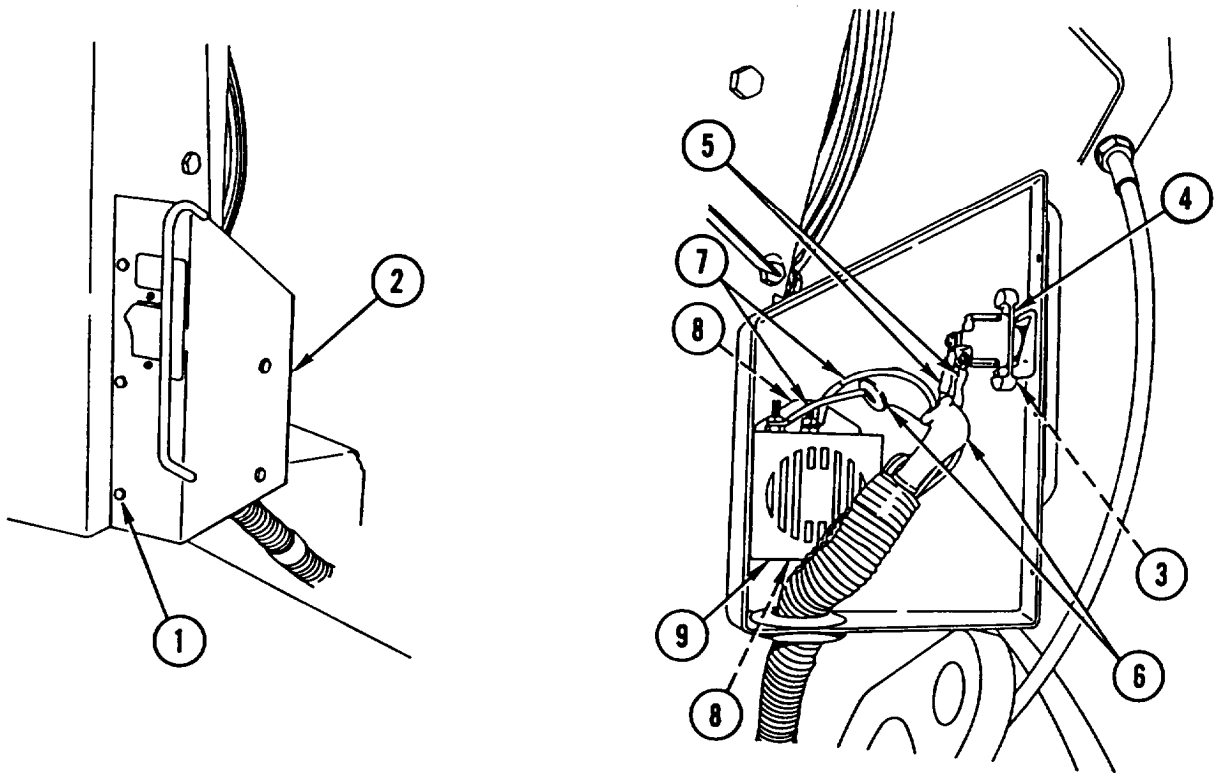
INSTALLATION

1. INSTALL low oil pressure ALARM (9), two screws (8), and two WIRES (7) and CAREFULLY ROLL rubber COVERS (6) BACK in place.
2. INSTALL two WIRES (5) on RPM switch (4).
3. INSTALL RPM SWITCH (4) and two screws (3).
4. INSTALL control TOWER (2) and five screws (1).

THROTTLE CONTROL SWITCH REPLACEMENT

This task covers: a. Removal b. Installation

INITIAL SETUP

Applicable Configuration:

HMMH

Tools and Special Equipment:

Tool Kit, SC 5180-90-CL-N26

Materials/Parts:

Washer, Lock (2)

Washer, Lock (2)

Equipment Condition:

Reference

Page 2-24

Page 2-23

Condition Description

Batteries Disconnected

Air Pressure Relieved

General Safety Instructions:

WARNING

Do not disconnect any air system lines or fittings unless vehicle engine is shut off and air system pressure is relieved. To do so could result in injury to personnel.

REMOVAL

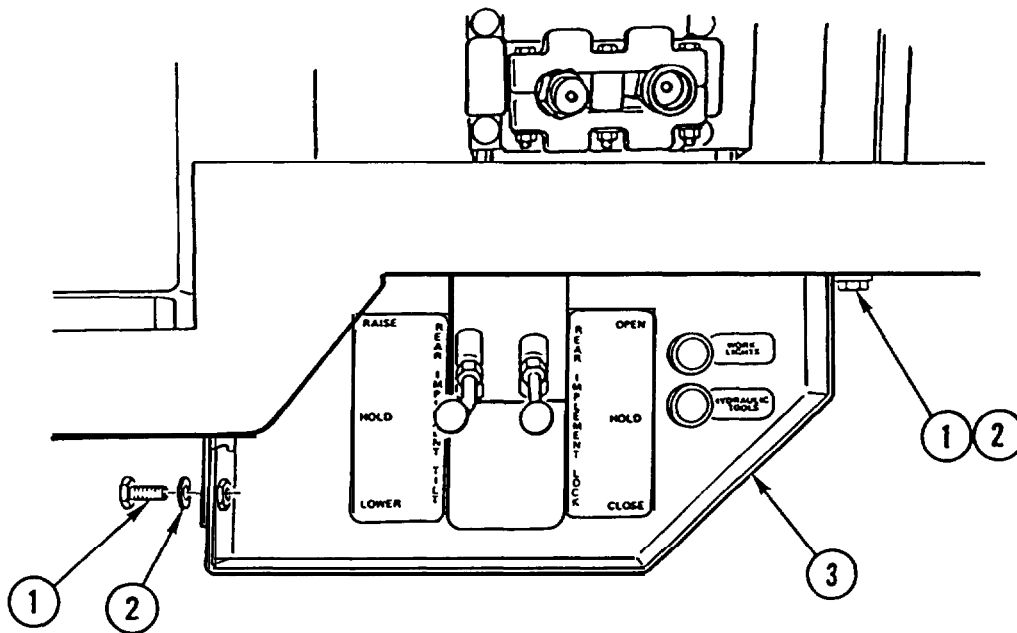

1. Remove seven SCREWS (1), and seven washers (2) from cabinet assembly (3).

THROTTLE CONTROL SWITCH REPLACEMENT (CONT)

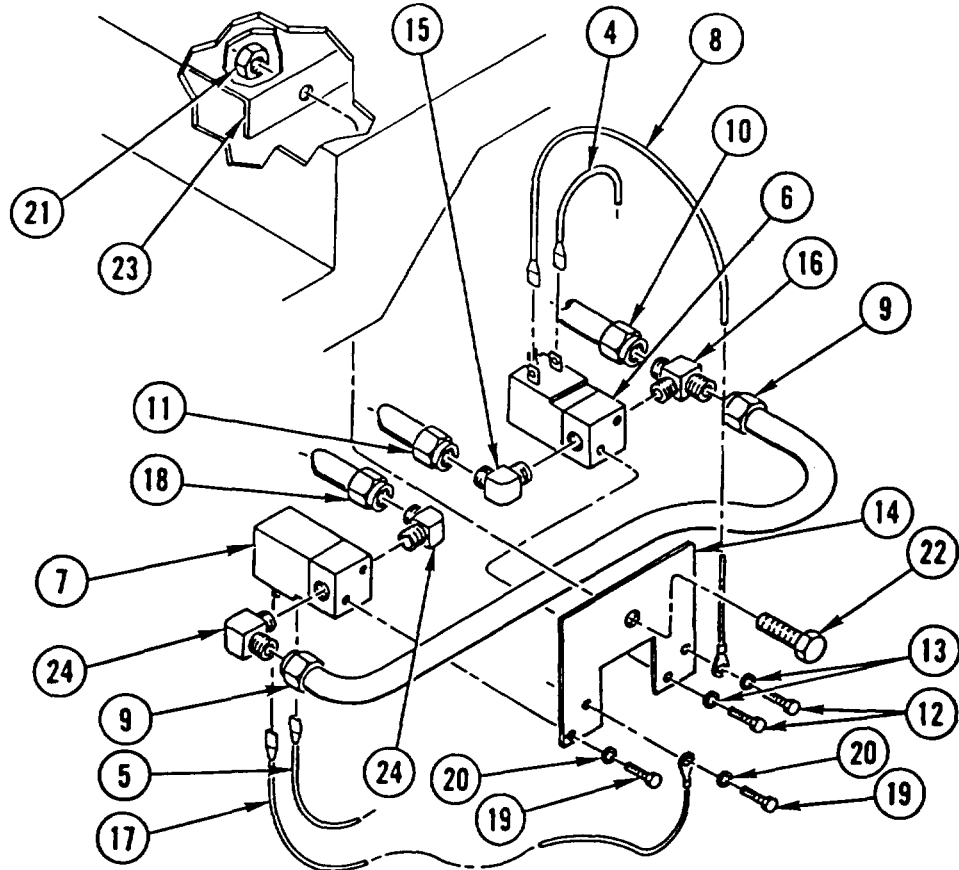
**NOTE**

Tag all wires and lines prior to disconnecting to aid in connecting.

2. DISCONNECT two WIRES (4 and 5) from two throttle switches (6 and 7) and SET CABINET assembly ASIDE.
3. DISCONNECT ground WIRE (8) from throttle switch (6).
4. DISCONNECT three air TUBES (9, 10, and 11) from throttle switch (6).
5. REMOVE two screws (12), two lock washers (13), ground WIRE (8), and throttle SWITCH (6) from bracket (14). DISCARD lock WASHERS.
6. REMOVE ELBOW (15) and TEE (16) from throttle switch (6).
7. DISCONNECT ground WIRE (17) from throttle switch (7).
8. DISCONNECT air TUBE (18) from throttle switch (7).
9. REMOVE two screws (19), two lock washers (20), ground WIRE (17), and throttle SWITCH (7) from bracket (14). DISCARD lock WASHERS.
10. REMOVE air TUBE (9) from throttle switch (7).
11. REMOVE nut (21), screw (22), and BRACKET (14) from platform (23).
12. REMOVE two ELBOWS (24) from throttle switch (7).

THROTTLE CONTROL SWITCH REPLACEMENT (CONT)

INSTALLATION

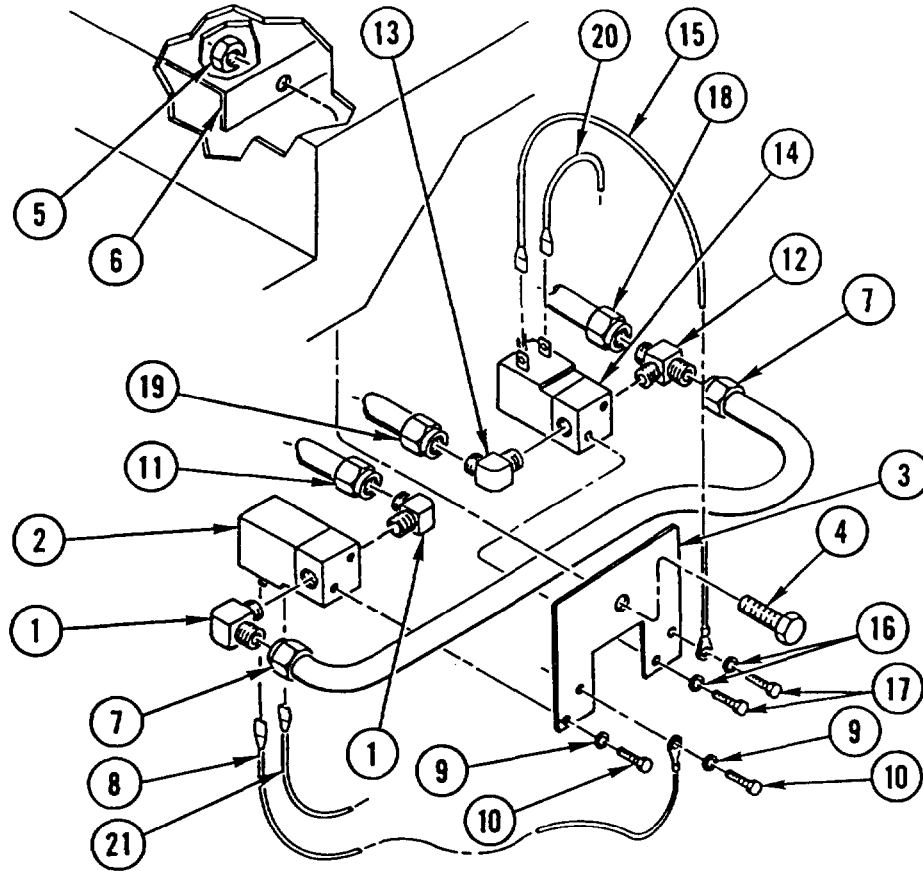

1. INSTALL two ELBOWS (1) on throttle switch (2).
2. INSTALL BRACKET (3), screw (4), and nut (5) on platform (6).
3. INSTALL air TUBE (7) on throttle switch (2).
4. INSTALL throttle SWITCH (2), ground WIRE (8), two new lock washers (9), and two screws (10) on bracket (3).
5. CONNECT air TUBE (11) to throttle switch (2).
6. CONNECT ground WIRE (8) to throttle switch (2).
7. INSTALL TEE (12) and elbow (13) on throttle switch (14).
8. INSTALL throttle SWITCH (14), ground WIRE (15), two new lock washers (16), and two screws (17) on bracket (3).
9. CONNECT three air TUBES (18, 19, and 7) to throttle switch (14).
10. CONNECT ground WIRE (15) to throttle switch (14).
11. CONNECT two WIRES (20 and 21) to two throttle switches (2 and 14).

THROTTLE CONTROL SWITCH REPLACEMENT (CONT)

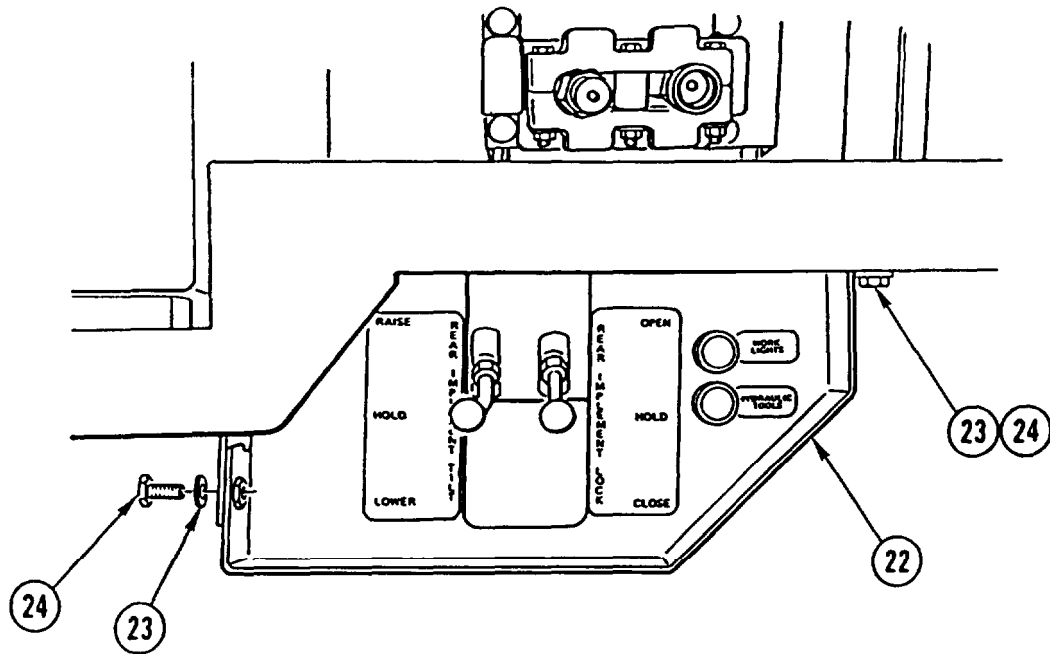

12. INSTALL CABINET assembly (22), seven washers (23), and seven screws (24).

NOTE

Follow-on Maintenance:

Connect batteries (page 2-24).

TOOL AND WORK LIGHT SWITCHES REPLACEMENT

This task covers: a. Removal b. Installation

INITIAL SETUP

Tools and Special Equipment:

Tool Kit, SC 5180-90-CL-N26

Personnel Required: (2)

General Safety instructions:

WARNING

Remove or disconnect batteries and turn vehicle MASTER disconnect switch OFF prior to performing maintenance in immediate battery area or working on electrical system. Such disconnections prevent electrical shock to personnel or equipment.

REMOVAL

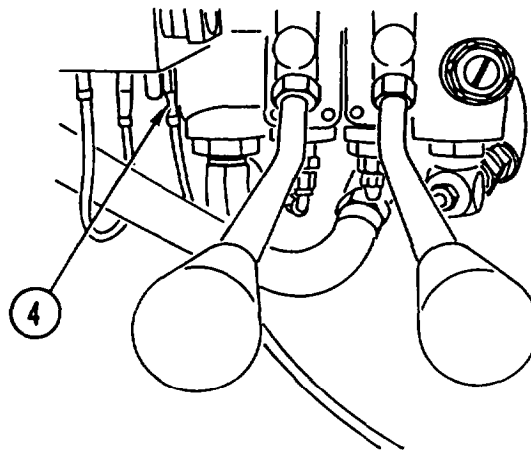
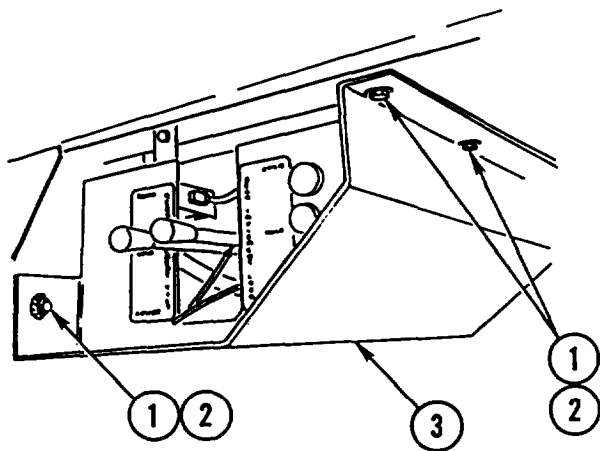

1. REMOVE seven screws (1), seven washers (2), and CABINET (3).

NOTE

Tag all wires prior to removal to aid in installation.

2. SUPPORT CABINET (3) and Disconnect WIRE (4).

TOOL AND WORK LIGHT SWITCHES REPLACEMENT (CONT)

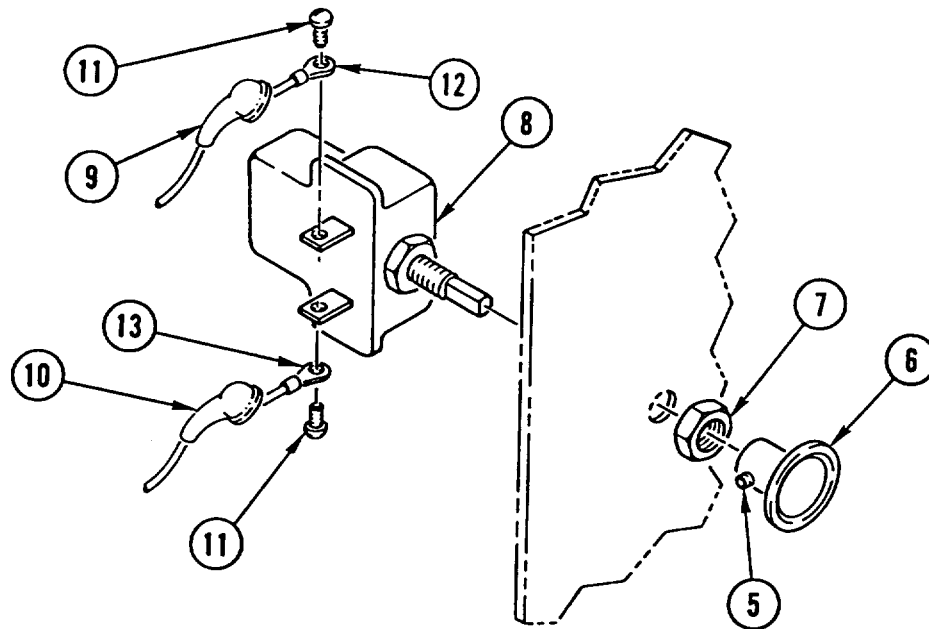

3. LOOSEN SETSCREW (5) and REMOVE KNOB (6).
4. REMOVE nut (7) and work light SWITCH (8).
5. ROLL BACK two rubber COVERS (9 and 10).
6. REMOVE two screws (11) and two WIRES (12 and 13).

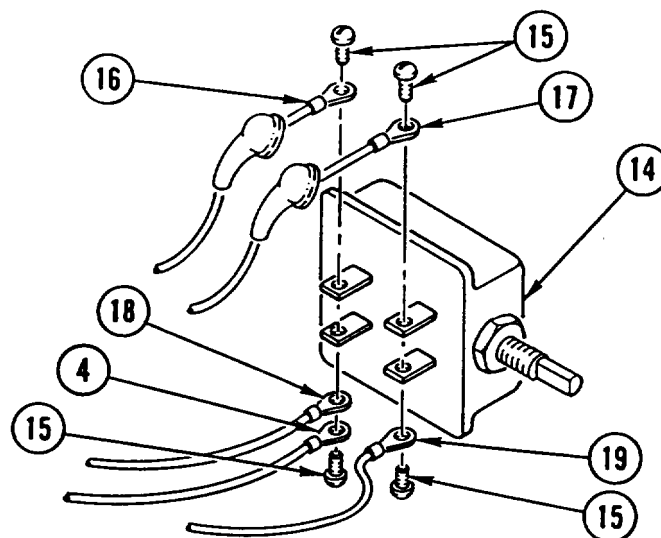

7. REPEAT STEPS 3 thru 5 for hydraulic tool SWITCH (14).
8. REMOVE four screws (15) and five WIRES (16, 17, 18, 19, and 4).

TOOL AND WORK LIGHT SWITCHES REPLACEMENT (CONT)

INSTALLATION

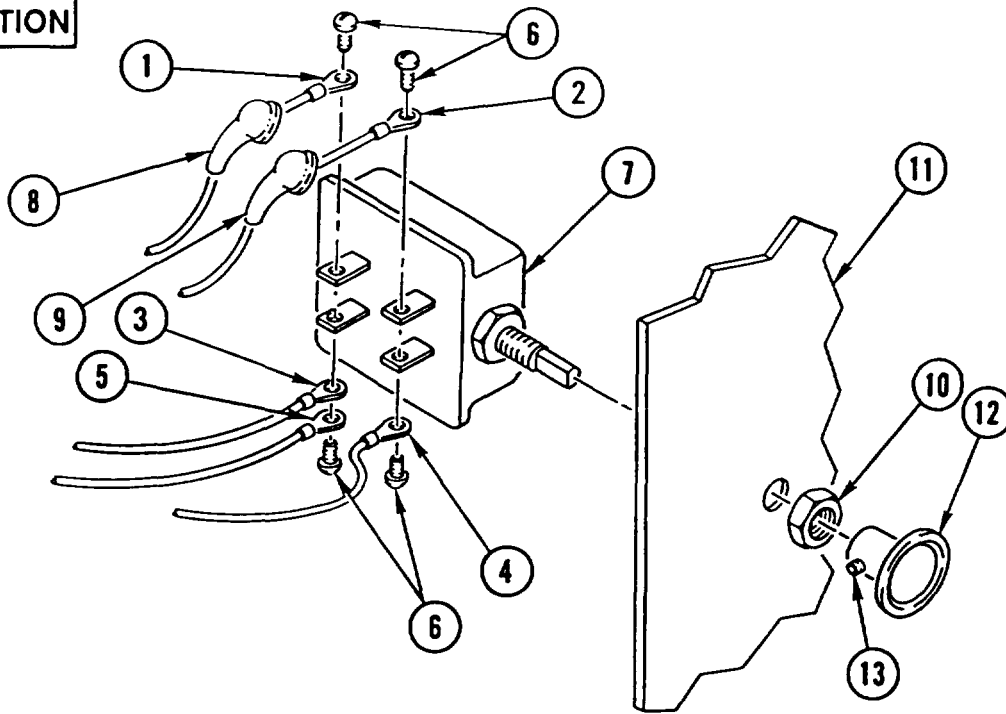

1. INSTALL five WIRES (1, 2, 3, 4, and 5) and four screws (6) on hydraulic tool switch (7)
2. ROLL two rubber COVERS (8 and 9) BACK into place.
3. INSTALL hydraulic tool SWITCH (7) and nut (10) in cabinet (11).
4. INSTALL KNOB (12) and TIGHTEN SETSCREW (13).

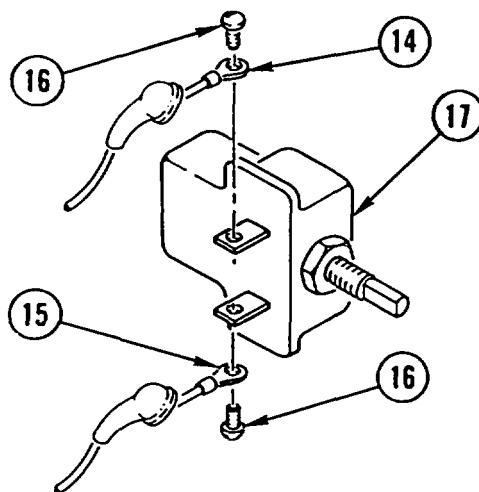

5. INSTALL two WIRES (14 and 15) and two screws (16) on work light switch (17).
6. REPEAT STEPS 2 thru 4 for work light SWITCH (17).

TOOL AND WORK LIGHT SWITCHES REPLACEMENT (CONT)

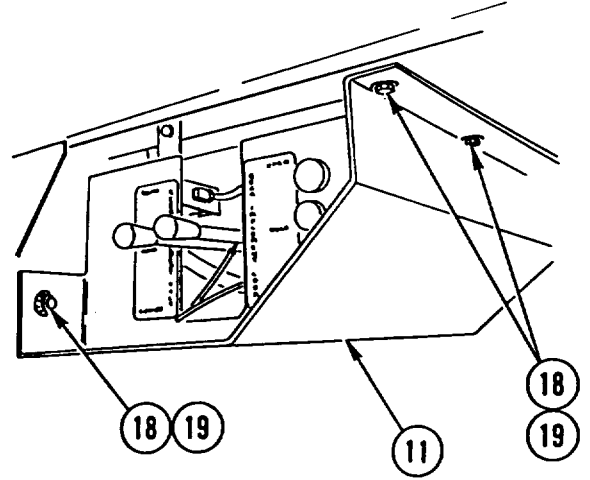
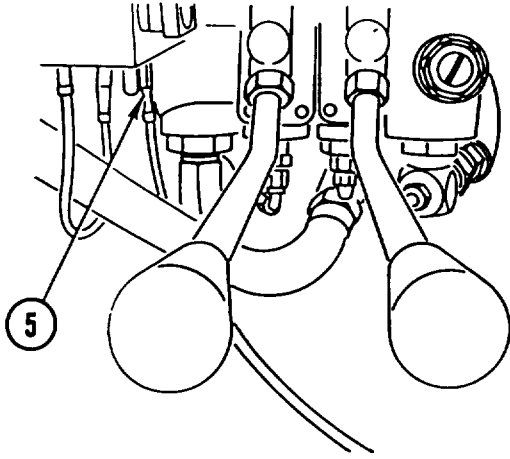

7. SUPPORT CABINET (11) and CONNECT WIRE (5).
8. INSTALL CABINET (11), seven screws (18), and seven washers (19).

FUSE HOLDER REPLACEMENT

This task covers: a. Removal b. Installation

INITIAL SETUP

Tools and Special Equipment:

Tool Kit, SC 5180-90-CL-N26

Materials/Parts:

Nut, Lock (4)

Equipment Condition:

Reference

Page 2-24

Page 4-388

Page 4-169

Condition Description

Batteries Disconnected

Outside Engine Hood Removed

Fuses Removed

REMOVAL

1. LOOSEN two screws (1).
2. PULL BRACKET (2) out enough to GAIN ACCESS to rear of fuse BOXES (3).

NOTE

Tag wire assemblies prior to disconnecting to aid in connecting.

3. Disconnect eight WIRE Assemblies (4) from back of fuse boxes (3).
4. REMOVE four screws (5), four lock nuts (6), four washers (7), and two fuse BOXES (3) from bracket (2). DISCARD lock NUTS.

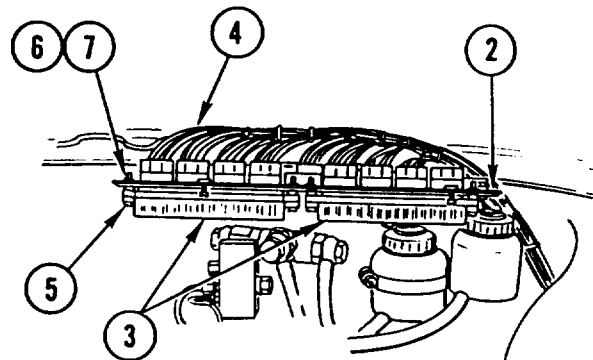
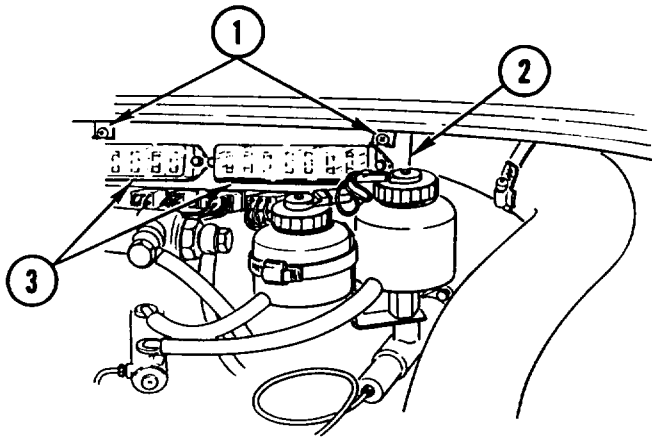

FUSE HOLDER REPLACEMENT (CONT)

INSTALLATION

1. INSTALL four screws (5), four washers (7), four new lock nuts (6), and two fuse BOXES (3) on bracket (2).
2. CONNECT eight WIRE ASSEMBLIES (4) to back of fuse boxes (3).

CAUTION

During installation of bracket, make sure wire assemblies are not binding to prevent damage to equipment.

3. INSTALL BRACKET (2) and TIGHTEN two SCREWS (1).

NOTE

Follow-on Maintenance:

Install fuses (page 4-169).
Connect batteries (page 2-24).
Install outside engine hood (page 4-388).

BRAKE LIGHT DIODE REPLACEMENT

This task covers: a. Removal b. Installation

INITIAL SETUP

Tools and Special Equipment:

Tool Kit, SC 5180-90-CL-N26

Materials/Parts:

Washer, Lock

Equipment Condition:

Reference

Page 4-388

Condition Description

Outside Engine Hood
Removed

General Safety Instructions:

WARNING

Remove or disconnect batteries and turn vehicle MASTER disconnect switch OFF prior to performing maintenance in immediate battery area or working on electrical system. Such disconnections prevent electrical shock to personnel or equipment.

REMOVAL

1. LOOSEN two captive SCREWS (1).
2. PULL BRACKET (2) out ENOUGH to gain ACCESS to rear of fuse panels (3).
3. DISCONNECT electrical CONNECTOR (4) from brake light diode (5).
4. REMOVE nut (6), lock washer (7), screw (8), and DIODE (5). DISCARD lock WASHER.

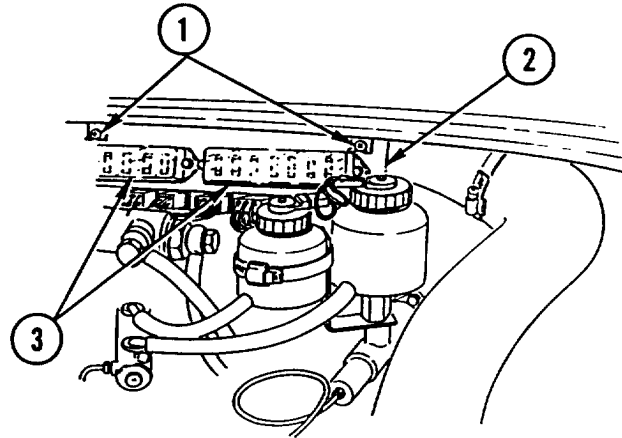

INSTALLATION

1. INSTALL screw (8), new lock washer (7), nut (6), and brake light DIODE (5).
2. CONNECT electrical CONNECTOR (4) to diode (5).
3. INSTALL BRACKET (2) and TIGHTEN two captive SCREWS (1).

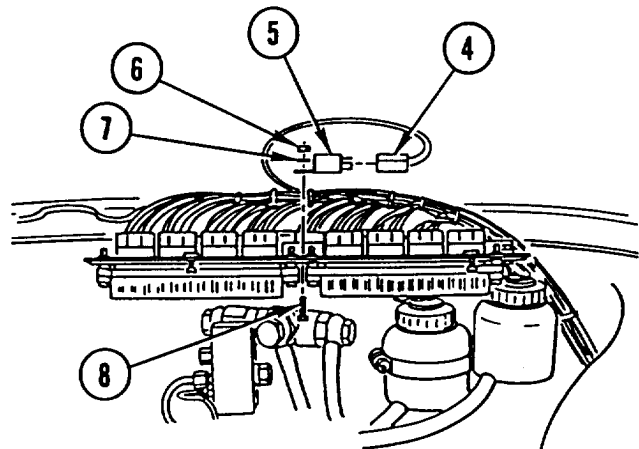

NOTE

Follow-on Maintenance:
Install outside engine hood (page 4-388).

FUSE REPLACEMENT

This task covers: a. Removal b. Installation

INITIAL SETUP

Equipment Condition:

Reference	Condition Description
Page 4-388	Outside Engine Hood Removed

General Safety Instructions:

WARNING

Remove or disconnect batteries and turn vehicle MASTER disconnect switch OFF prior to performing maintenance in immediate battery area or working on electrical system. Such disconnections prevent electrical shock to personnel or equipment.

Fuse No.	Fuse Box 2	Amp
1	Left taillight	8
2	Right taillight	8
3	Left front marker light	8
4	Right front marker light	8
5	Reserved	8
6	Windshield heater	16
7	Intervehicular connector	8
8	Blackout driving light	8
9	Left front low beam	8
10	Right front low beam	8
11	Left front high beam	8
12	Right front high beam	8

Fuse No.	Fuse Box 1	Amp
1	Oil cooler	16
2	Windshield wiper	8
3	Starter interlock	8
4	Heater	8
5	Horn	8
6	Turn signal, emergency flasher	8
7	Rear work light, reverse alarm	16
8	Stop light	8
9	instrument lights	8
10	Cold start system	8
11	Blackout taillight	8
12	Front blackout markers light	8

REMOVAL

1. REMOVE access COVERS (1) and FUSE(S), as required.
2. USE TABLE ABOVE TO DETERMINE CORRECT FUSE SIZE.

INSTALLATION

INSTALL new FUSE(S) and access COVERS (1).

NOTE

Follow-on Maintenance:
Install outside engine hood (page 4-388).

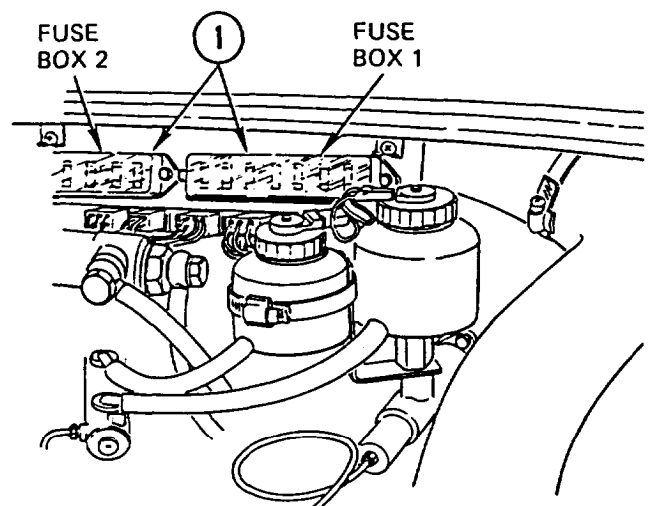

LOW OIL PRESSURE AND HIGH WATER TEMPERATURE ALARM REPLACEMENT

This task covers: a. Removal b. Installation

INITIAL SETUP

Tools and Special Equipment:

Tool Kit, SC 5180-90-CL-N26

General Safety Instructions:

WARNING

Remove or disconnect batteries and turn vehicle MASTER disconnect switch OFF prior to performing maintenance in immediate battery area or working on electrical system. Such disconnections prevent electrical shock to personnel or equipment.

REMOVAL

1. REMOVE five screws (1) and TOWER (2)

NOTE

Tag wires prior to disconnecting to aid in connecting.

2. CAREFULLY ROLL BACK rubber COVERS (3) and DISCONNECT two WIRES (4).
3. REMOVE two screws (5), two nuts (6) and ALARM (7).

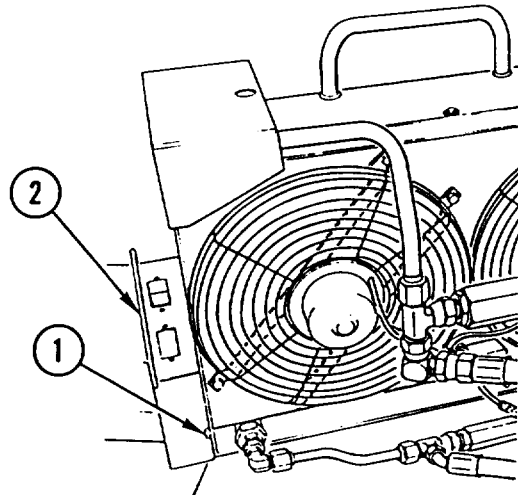

INSTALLATION

1. INSTALL ALARM (7), two screws (5), and two nuts (6).
2. CONNECT two WIRES (4) and CAREFULLY ROLL rubber COVERS (3) BACK in place.
3. INSTALL TOWER (2) and five screws (1).

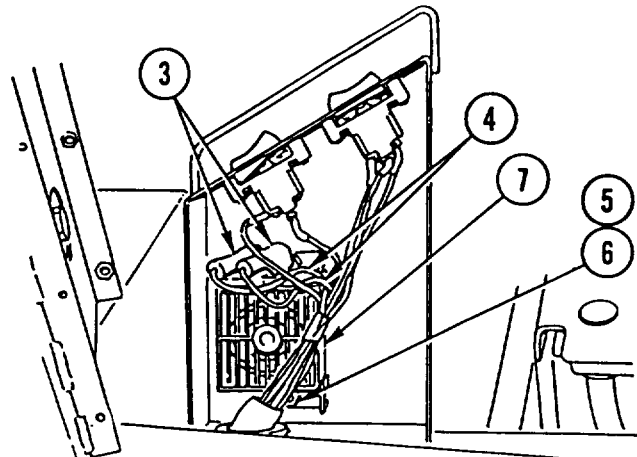

MAIN (MASTER) DISCONNECT SWITCH REPLACEMENT

This task covers: a. Removal b. Installation

INITIAL SETUP

Tools and Special Equipment:

Tool Kit, SC 5180-90-CL-N26

Materials/Parts:

Washer, Spring
Tension (2)

Equipment Condition:

Reference

Page 2-24

Condition Description

Batteries Disconnected

REMOVAL

1. REMOVE main disconnect HANDLE (1).
2. REMOVE eight bolts (2), eight washers (3), and cover PLATE (4).
3. REMOVE two screws (5).
4. LOOSEN jam NUT (6) and REMOVE KNOB (7) and jam nut (6). LIFT PLATE (4) and MOVE trailer brake control VALVE (8) ASIDE.

NOTE

Tag leads prior to disconnecting to aid in connecting.

5. CAREFULLY ROLL BACK rubber COVERS (9) and DISCONNECT two LEADS (10).
6. REMOVE two nuts (11), two spring tension washers (12), two screws (13), and main disconnect SWITCH (14). DISCARD spring tension WASHERS.

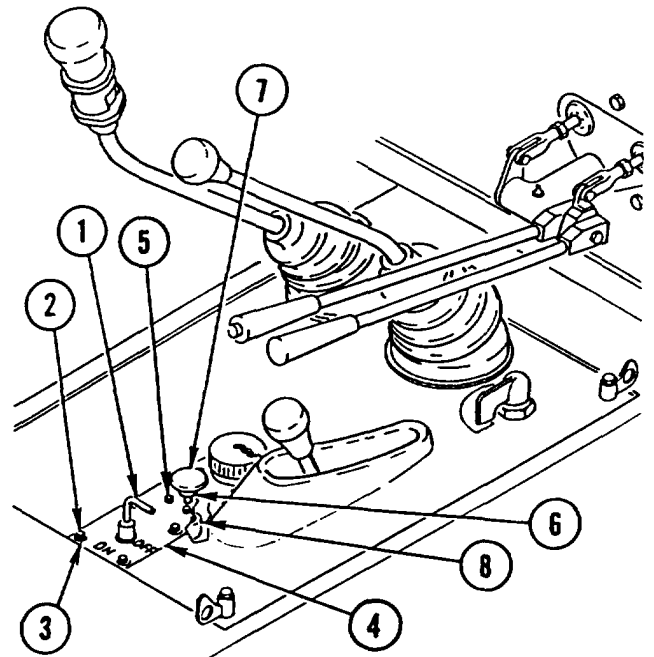

INSTALLATION

1. INSTALL main disconnect SWITCH (14), two screws (13), two new spring tension washers (12), and two nuts (11).
2. CONNECT two LEADS (10) and CAREFULLY ROLL rubber COVERS (9) BACK over terminals.
3. POSITION trailer brake control VALVE (8) and INSTALL jam nut (6), KNOB (7), and two SCREWS (5). TIGHTEN jam NUT (6).
4. INSTALL cover PLATE (4), eight washers (3), and eight bolts (2).
5. INSTALL main disconnect HANDLE (1).

NOTE

Follow-on Maintenance:
Connect batteries (page 2-24).

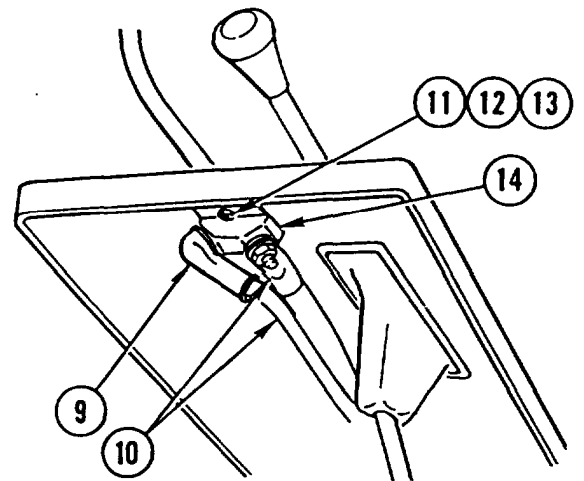

SLAVE RECEPTACLE REPLACEMENT

This task covers: a. Removal b. Installation

INITIAL SETUP

Tools and Special Equipment:

Tool Kit, SC 5180-90-CL-N26

Materials/Parts:

Washer, Spring
Tension (2)

Nut, Lock (2)

Equipment Condition:

Reference

Page 2-24

Condition Description

Batteries Disconnected

REMOVAL

1. REMOVE two screws (1), two spring tension washers (2), and COVER (3). DISCARD spring tension WASHERS.

NOTE

Tag leads prior to removal to aid in installation.

2. DISCONNECT two LEADS (4) from slave receptacle (5).
3. REMOVE four nuts (6), four screws (7), and slave RECEPTACLE (5).
4. REMOVE two screws (8), two lock nuts (9), and BRACKET (10). DISCARD lock NUTS.

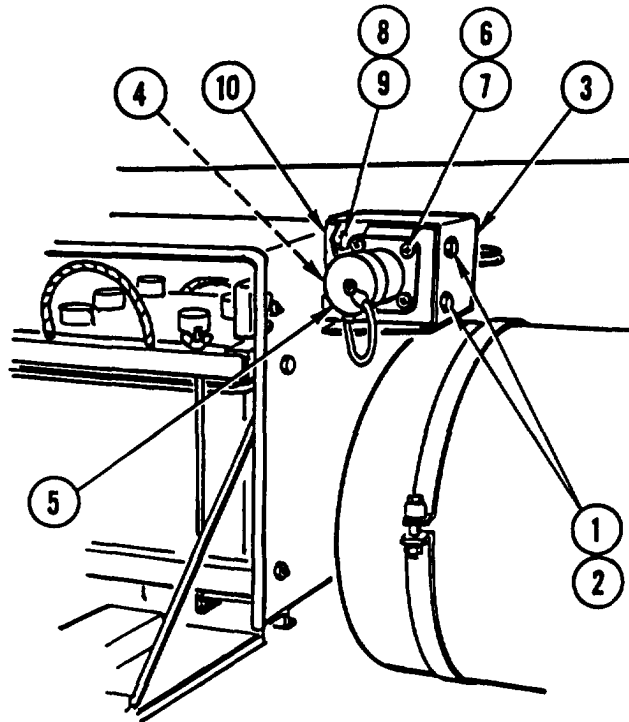

INSTALLATION

1. INSTALL BRACKET (10), two screws (8), and two new lock nuts (9).
2. INSTALL slave RECEPTACLE (5), four screws (7), and four nuts (6).
3. CONNECT two LEADS (4) to slave receptacle (5).
4. INSTALL COVER (3), two new spring tension washers (2), and two screws (1).

NOTE

Follow-on Maintenance:
Connect batteries (page 2-24).

HEADLIGHT REPLACEMENT

This task covers: a. Removal b. Installation

INITIAL SETUP

Tools and Special Equipment:

Tool Kit, SC 5180-90-CL-N26

Materials/Parts:

Gasket

Equipment Condition:

Reference

Page 4-794

Condition Description

Front Loader (SEE)
Removed

General Safety Instructions:

WARNING

- SEE should not be operated with front loader removed, except in a maintenance facility. When maintenance is required and front loader is removed, never operate SEE at speeds greater than 5 mph. Tractor stability and handling characteristics are greatly affected with front loader removed. This could cause loss of control and injury to personnel or damage to vehicle.
- Remove or disconnect batteries and turn vehicle MASTER disconnect switch OFF prior to performing maintenance in immediate battery area or working on electrical system. Such disconnections prevent electrical shock to personnel or equipment.

HEADLIGHT REPLACEMENT (CONT)

REMOVAL

NOTE

- Procedure is the same for both vehicles.
- Procedure is the same for both headlights.

1. REMOVE three screws (1), three washers (2), and GUARD (3).
2. REMOVE screw (4) and RETAINER (5).
3. LOOSEN three SCREWS (6) and REMOVE RETAINER (7).
4. REMOVE SOCKET (8) from lamp (9).
5. REMOVE three screws (10), three nuts (11), three washers (12), RETAINER (13), and gasket (14). DISCARD GASKET.
6. REMOVE GROMMET (15) from retainer (13).

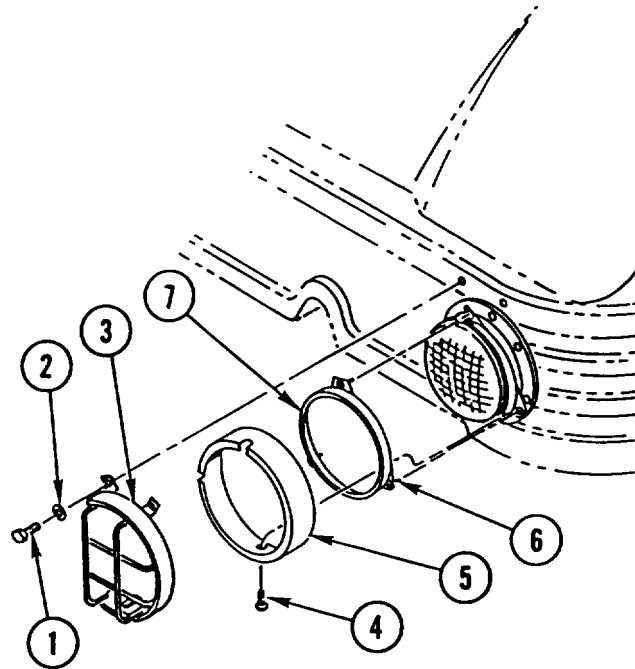

INSTALLATION

NOTE

- Procedure is the same for both vehicles.
- Procedure is the same for both headlights.

1. INSTALL GROMMET (15) in retainer (13).
2. INSTALL new gasket (14), RETAINER (13), three screws (10), three washers (12), and three nuts (11).
3. INSTALL SOCKET (8) in lamp (9).
4. INSTALL RETAINER (7) and TIGHTEN three SCREWS (6).
5. INSTALL RETAINER (5) and screw (4).
6. INSTALL GUARD (3), three washers (2), and three screws (1).

NOTE

Follow-on Maintenance:

Install front loader (SEE) (page 4-794).

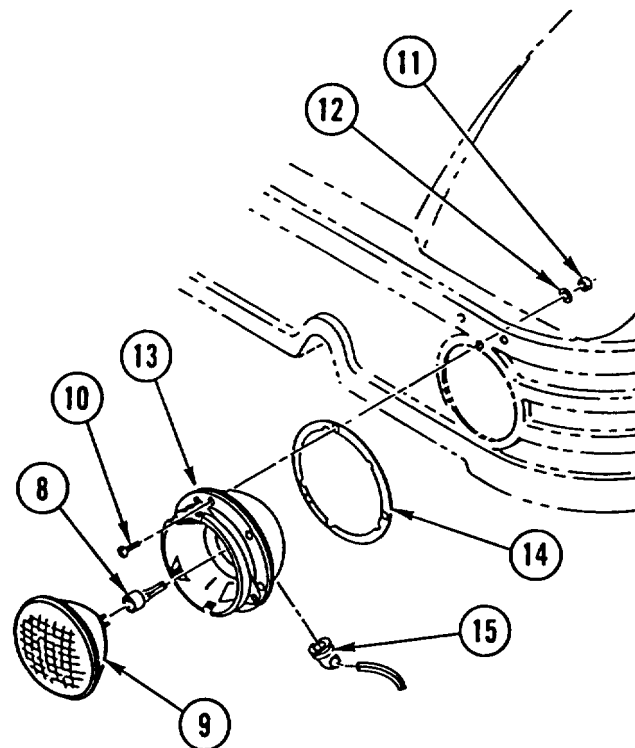

AUXILIARY HEADLIGHT REPLACEMENT

This task covers: a. Removal b. Installation

INITIAL SETUP

Tools and Special Equipment:

Tool Kit, SC 5180-90-CL-N26

General Safety Instructions:

WARNING

Remove or disconnect batteries and turn vehicle MASTER disconnect switch OFF prior to performing maintenance in immediate battery area or working on electrical system. Such disconnections prevent electrical shock to personnel or equipment.

REMOVAL

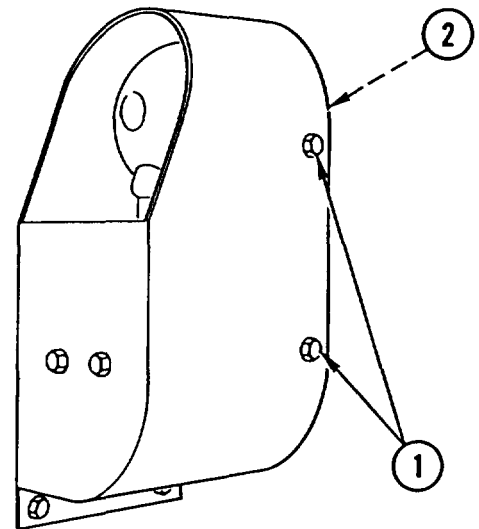
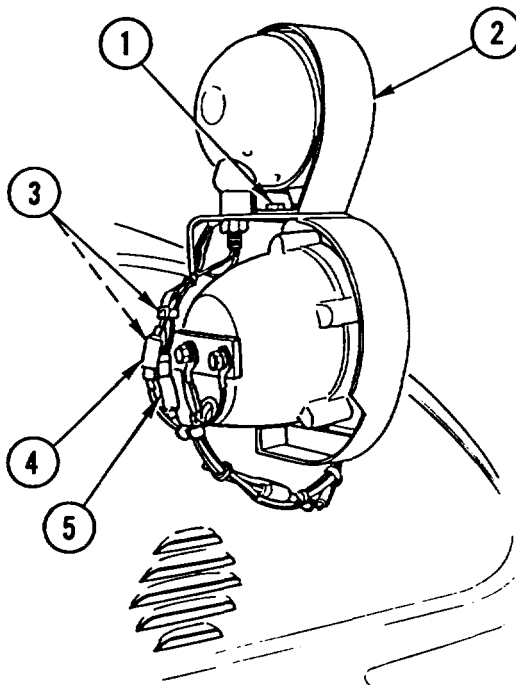

HMMH
ONLY

NOTE

Procedure is the same for both auxiliary headlights.

1. REMOVE two bolts (1), lamp GUARD (2), and two retaining straps (3).
2. DISCONNECT two quick DISCONNECTS (4 and 5).

AUXILIARY HEADLIGHT REPLACEMENT (CONT)

NOTE

Steps 3 thru 5 are for black cable.

3. SLIDE INSULATOR (6) BACK on cable (7).
4. CUTOFF TERMINAL (8).
5. REMOVE two INSULATORS (9 and 6).

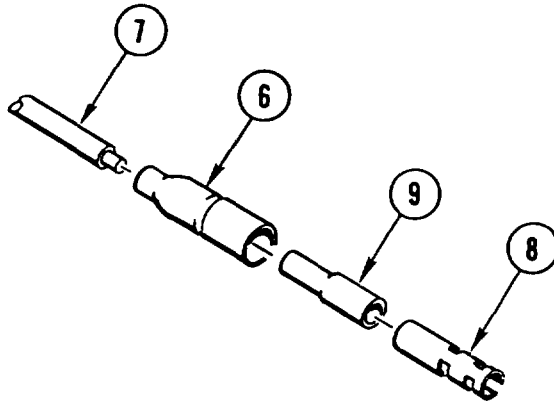

NOTE

Steps 6 thru 8 are for red cable.

6. SLIDE INSULATOR (10) BACK on cable (11).
7. CUT OFF TERMINAL (12).
8. REMOVE slotted washer (13) and INSULATOR (10).

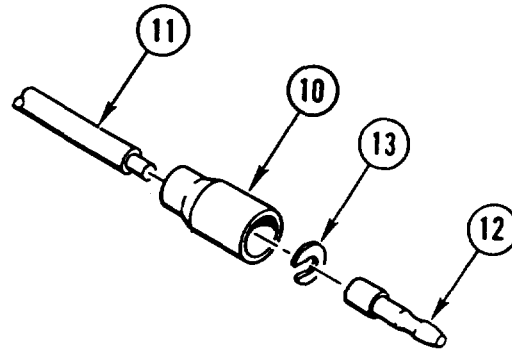

9. REMOVE nut (14), ground WIRE (15), bushing (16), and HEADLIGHT (17).

10. REMOVE MOUNT (18) and HOUSING (19).

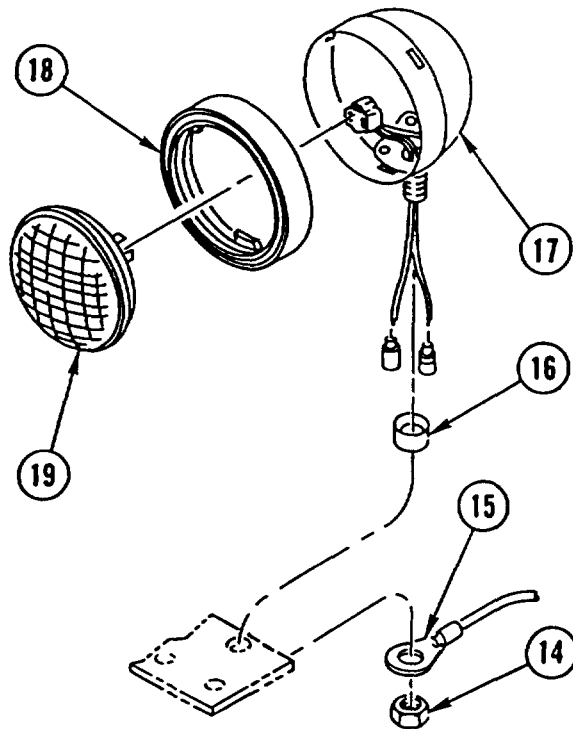

AUXILIARY HEADLIGHT REPLACEMENT (CONT)

INSTALLATION

NOTE

Procedure is the same for both auxiliary headlights.

1. INSTALL HOUSING (1) and MOUNT (2).
2. INSTALL HEADLIGHT (3), bushing (4), ground WIRE (5), and nut (6).

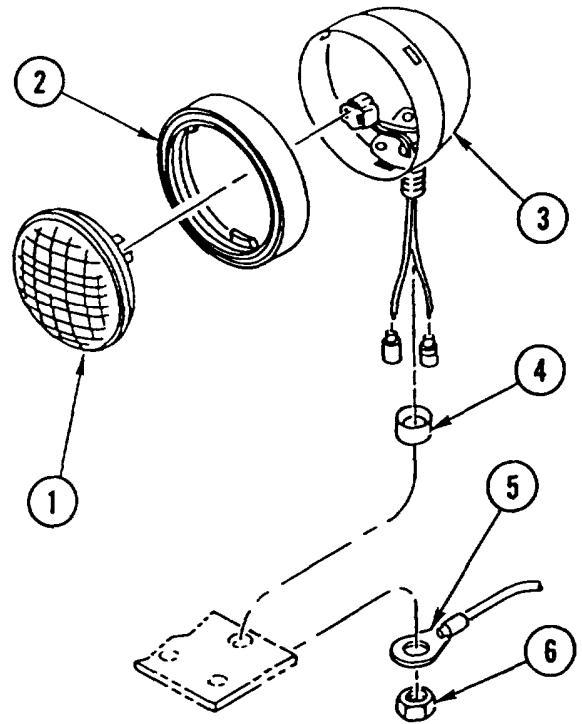

NOTE

Steps 3 thru 6 are for black cable.

3. STRIP cable INSULATION (7) approximately 1/8 in. (3 mm).
4. SLIDE two INSULATORS (8 and 9) OVER cable (7).
5. PLACE CABLE (7) in cylindrical end of terminal (10), and CRIMP.
6. SLIDE two INSULATORS (9 and 8) OVER terminal (10).

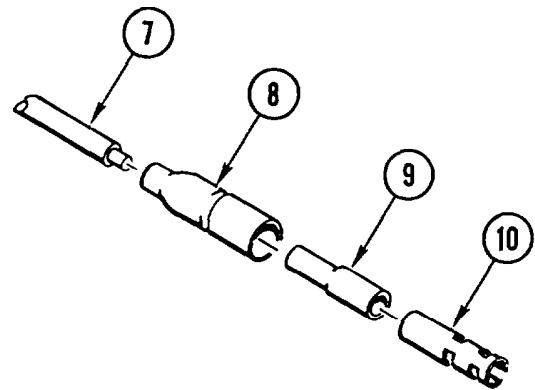

NOTE

Steps 7 thru 10 are for red cable.

7. STRIP cable INSULATION (11) equal to depth of terminal well (12).
8. SLIDE INSULATOR (13) OVER cable (11).
9. INSERT CABLE (11) into terminal well (12), and CRIMP.
10. PLACE slotted WASHER (14) OVER CABLE (11) AT CRIMPED JUNCTION and SLIDE INSULATOR (13) OVER slotted washer (14) and terminal (12).

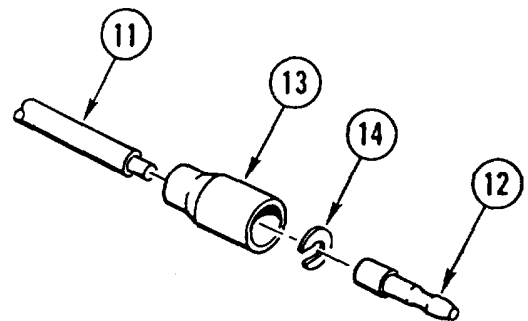

AUXILIARY HEADLIGHT REPLACEMENT (CONT)

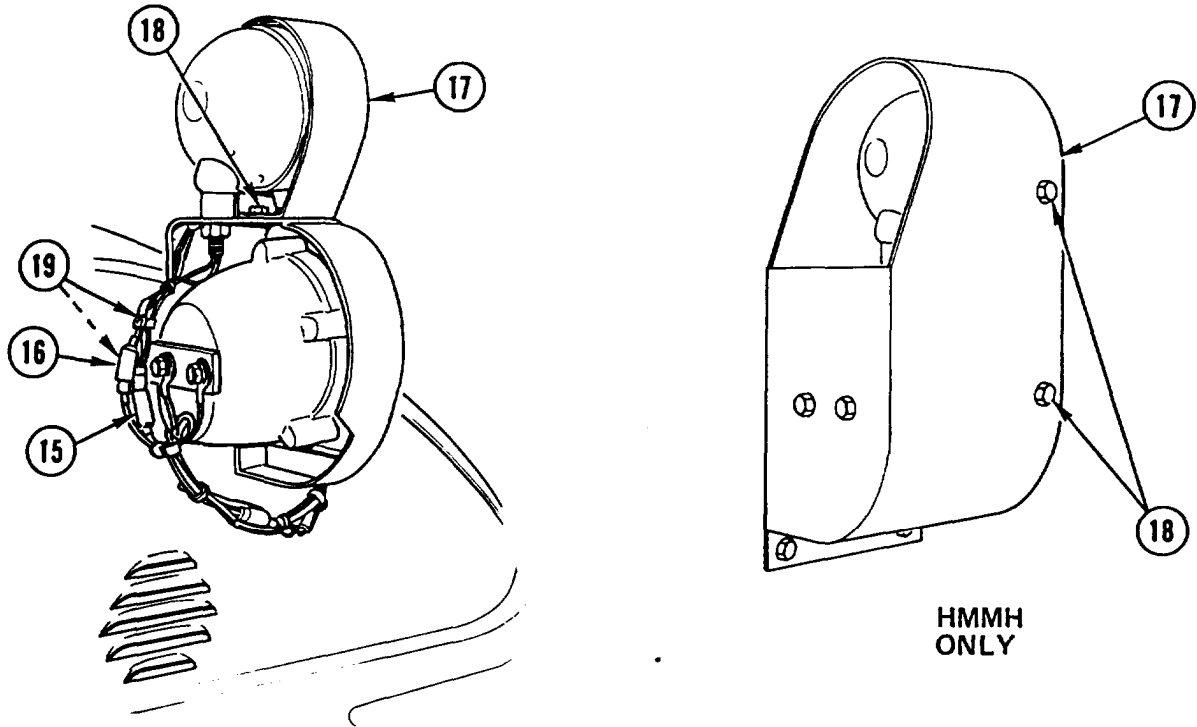

11. CONNECT two quick DISCONNECTS (15 and 16).
12. INSTALL lamp GUARD (17), two bolts (18), and two retaining straps (19).

AUXILIARY HEADLIGHT ADJUSTMENT

This task covers: Adjustment

INITIAL SETUP

Tools and Special Equipment:

Tool Kit, SC 5180-90-CL-N26

References:

TM 5-2420-224-10

Personnel Required: (2)

ADJUSTMENT

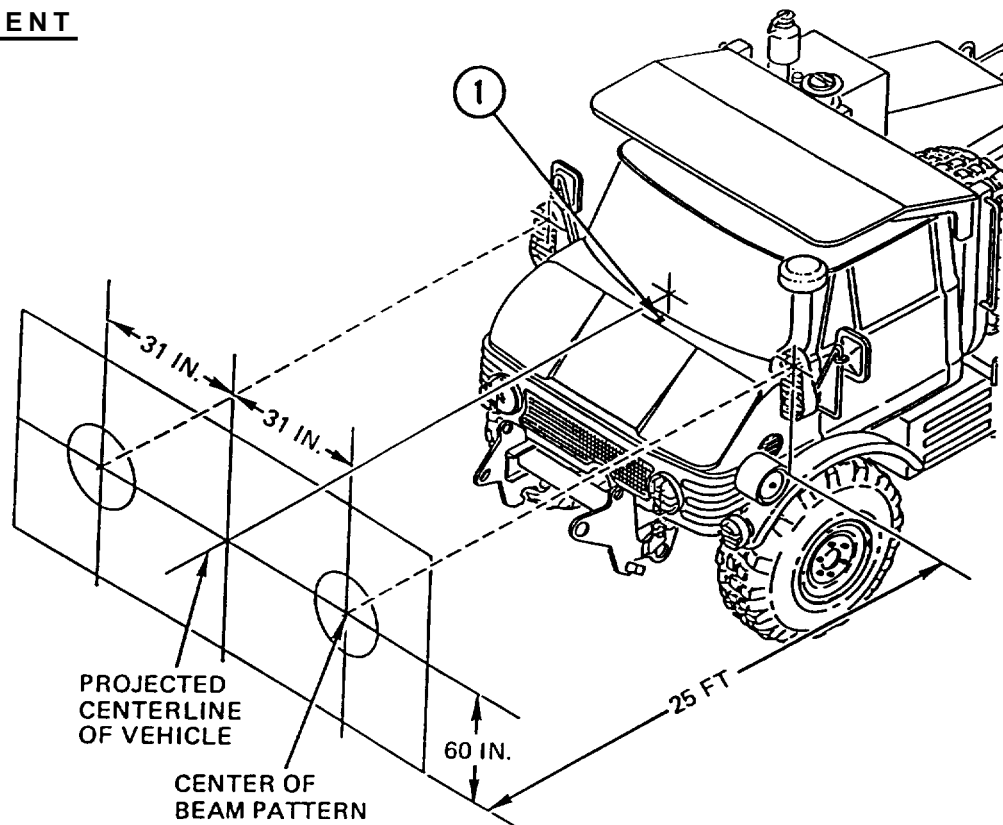

NOTE

- Make sure front loader (SEE) or forklift (HMMH) and backhoe (SEE) or crane (HMMH) are in travel position (TM 5-2420-224-10).
- Make sure all tires are properly inflated and there is no load on vehicle.
- Procedure is the same for both vehicles.

1. Centerline of vehicle is located at windshield washer nozzle (1).
2. Park vehicle 25 ft (7.63 m) from light colored wall and mark vehicle centerline on wall at floor level.
3. To determine high-beam auxiliary headlight centerline, measure 31 in. (79 cm) at floor level in both directions from vehicle centerline on wall and up 60 in. (152 cm) on both sides.

AUXILIARY HEADLIGHT ADJUSTMENT (CONT)

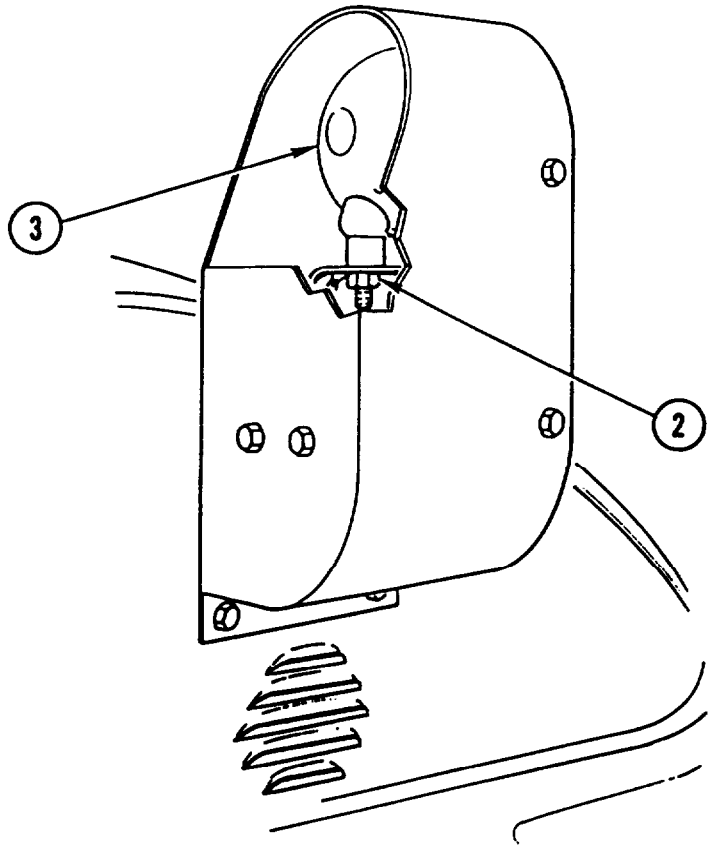

4. With auxiliary headlights on high beam, adjust each auxiliary headlight until highest intensity point is just to right and just below auxiliary headlight centerline ± 4 in. (± 10.2 cm). To adjust intensity point, loosen nut (2) and rotate light (3) up and down or sideways until desired intensity point is reached.

FRONT BLACKOUT LIGHT REPLACEMENT AND REPAIR

This task covers: a. Removal b. Disassembly c. Assembly d. Installation

INITIAL SETUP

Tools and Special Equipment:

Tool Kit, SC 5180-90-CL-N26

Materials/Parts:

Washer, Lock

Washer, Lock

Gasket

Gasket

General Safety Instructions:

WARNING

Remove or disconnect batteries and turn vehicle MASTER disconnect switch OFF prior to performing maintenance in immediate battery area or working on electrical system. Such disconnections prevent electrical shock to personnel or equipment.

REMOVAL

NOTE

Procedure is the same for both vehicles. However, front blackout light for SEE tractor is located on front loader arm during convoy operations only.

1. REMOVE two bolts (1) and GUARD (2).
2. DISCONNECT CABLE (3).
3. REMOVE nut (4), lock washer (5), and HEADLIGHT ASSEMBLY (6). DISCARD lock WASHER.

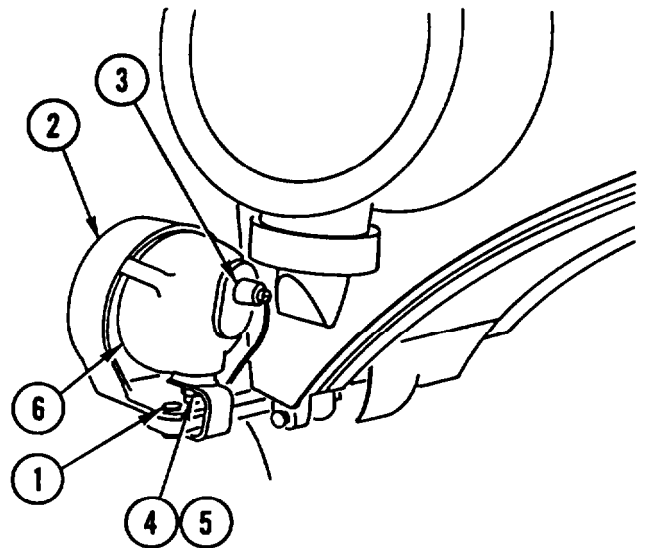

FRONT BLACKOUT LIGHT REPLACEMENT AND REPAIR (CONT)

DISASSEMBLY

1. REMOVE washer (1) and lock WASHER (2). DISCARD lock WASHER.
2. LOOSEN three SCREWS (3) and REMOVE DOOR (4).
3. REMOVE and DISCARD two GASKETS (5 and 6).
4. REMOVE LAMP (7).

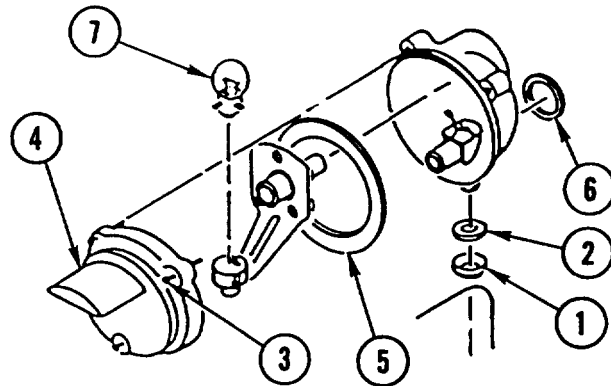

ASSEMBLY

1. INSTALL LAMP (7).
2. INSTALL two new GASKETS (6 and 5).
3. INSTALL DOOR (4) and TIGHTEN three SCREWS (3).
4. INSTALL new lock WASHER (2) and washer (1).

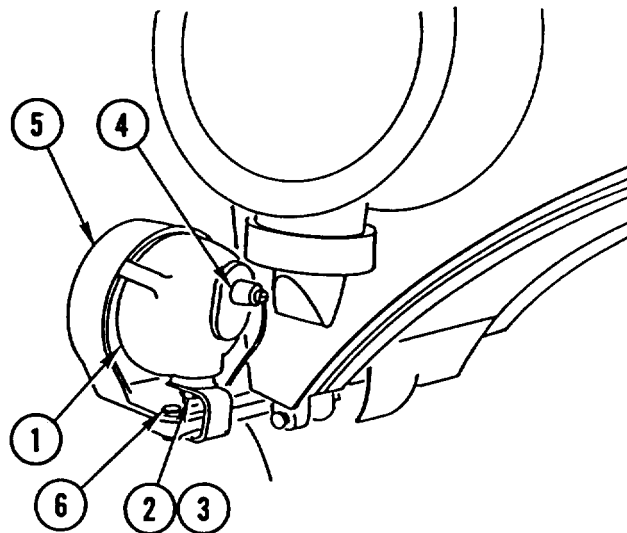

NOTE

Procedure is the same for both vehicles. However, front blackout light for SEE tractor is located on front loader arm during convoy operations only.

1. INSTALL HEADLIGHT ASSEMBLY (1), new lock washer (2), and nut (3).
2. CONNECT CABLE (4).
3. INSTALL GUARD (5) and two bolts (6).

FRONT COMPOSITE LIGHT REPLACEMENT AND REPAIR

This task covers: a. Removal b. Disassembly c. Assembly d. Installation

INITIAL SETUP

Tools and Special Equipment:

Tool Kit, SC 5180-90-CL-N26

Materials/Parts:

Washer, Lock (2)

Packing

General Safety Instructions:

WARNING

Remove or disconnect batteries and turn vehicle MASTER disconnect switch OFF prior to performing maintenance in immediate battery area or working on electrical system. Such disconnections prevent electrical shock to personnel or equipment.

REMOVAL

NOTE

Procedure is the same for both lights.

1. DISCONNECT two INSULATORS (1) from headlight (2).
2. DISCONNECT three quick-disconnect TERMINALS (3).
3. REMOVE three retaining STRAPS (4).
4. REMOVE two screws (5), two lock washers (6), WIRE (7), and LIGHT (8). DISCARD lock WASHERS.

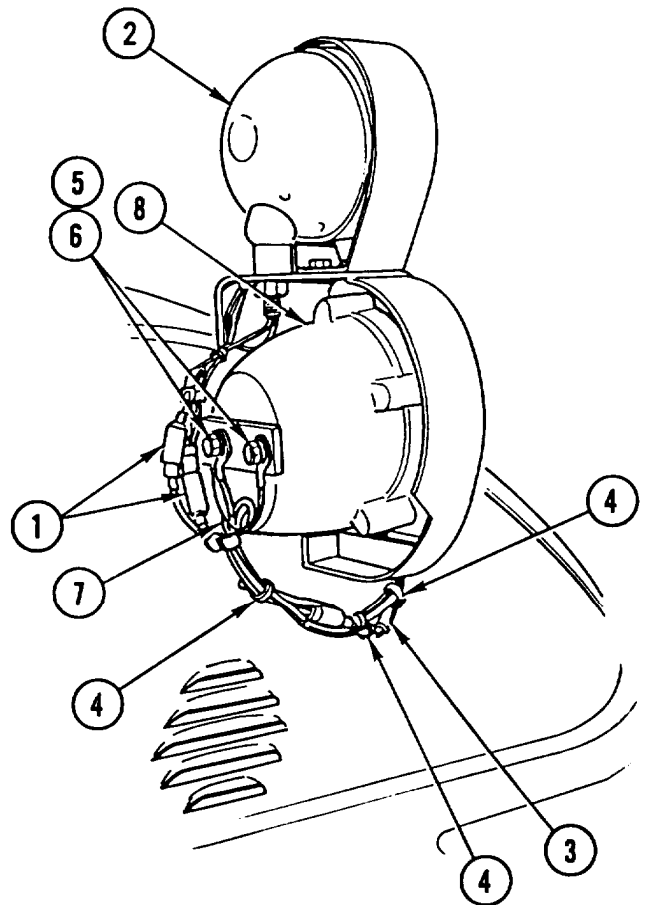

FRONT COMPOSITE LIGHT REPLACEMENT AND REPAIR (CONT)

DISASSEMBLY

1. LOOSEN five SCREWS (1) and REMOVE RETAINER (2) and packing (3). DISCARD PACKING.
2. REMOVE three LAMPS (4, 5, and 6).
3. REMOVE three screws (7) and lamp HOLDER (8).

NOTE

Tag wires prior to disconnecting to aid in connecting.

4. DISCONNECT two WIRES (9) from housing (10).

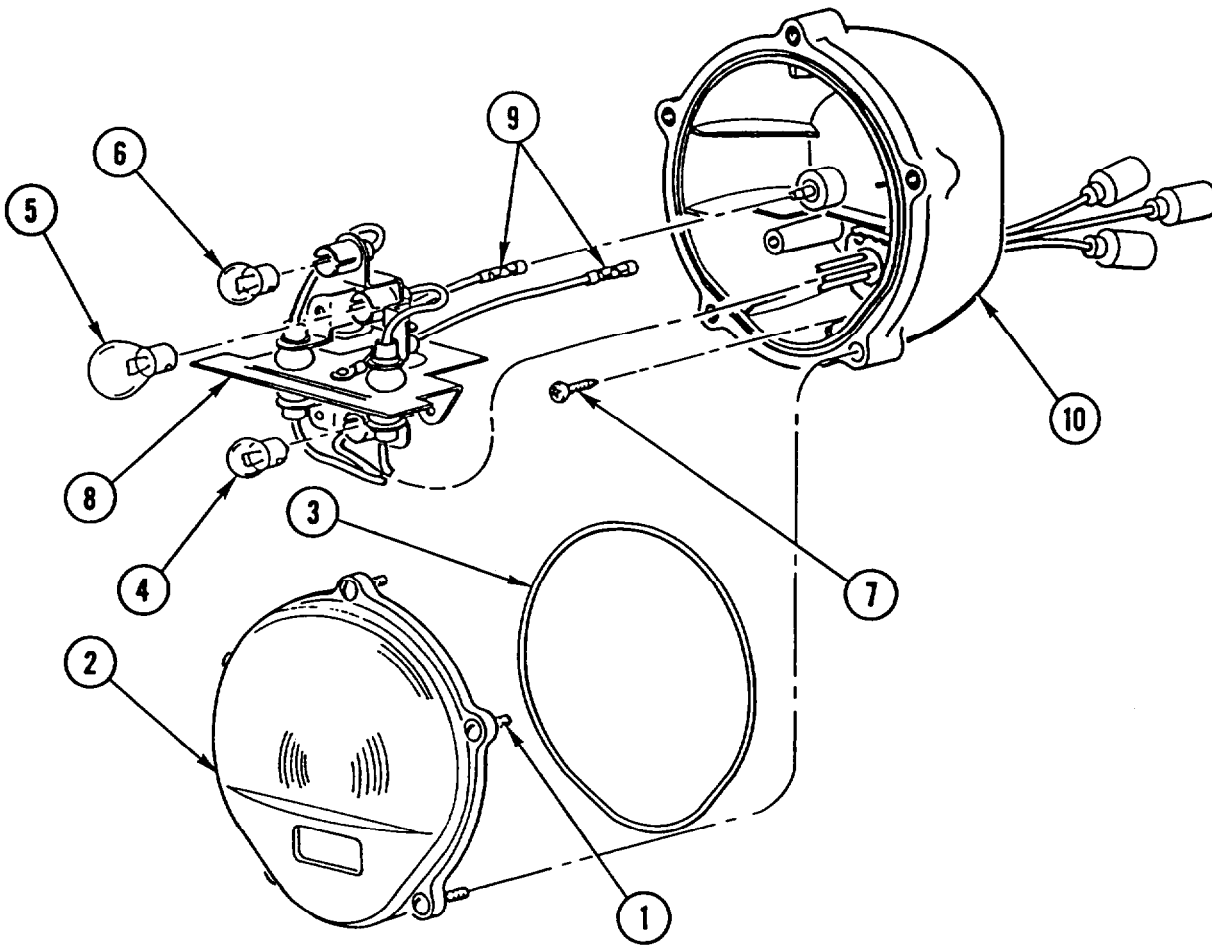

ASSEMBLY

1. CONNECT two WIRES (9) to housing (10).
2. INSTALL lamp HOLDER (8) and three screws (7).
3. INSTALL three LAMPS (4, 5, and 6).
4. INSTALL new packing (3) and RETAINER (2) and TIGHTEN five screws (1).

FRONT COMPOSITE LIGHT REPLACEMENT AND REPAIR (CONT)

INSTALLATION**NOTE**

Procedure is the same for both lights.

1. INSTALL LIGHT (1), WIRE (2), two screws (3), and two new lock washers (4).
2. INSTALL three retaining STRAPS (5).
3. CONNECT three quick-disconnect TERMINALS (6).
4. CONNECT two INSULATORS (7) to headlight (8).

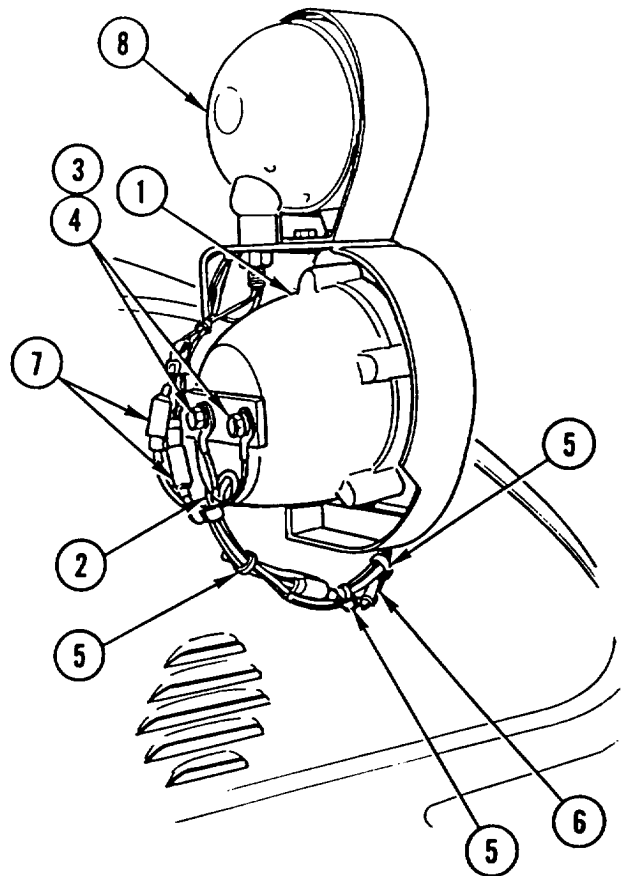

WORK LIGHT REPLACEMENT AND REPAIR

This task covers: a. Removal b. Disassembly c. Assembly d. Installation

INITIAL SETUP

Tools and Special Equipment:

Tool Kit, SC 5180-90-CL-N26

Materials/Parts:

Washer, Lock (2)

General Safety Instructions:

WARNING

Remove or disconnect batteries and turn vehicle MASTER disconnect switch OFF prior to performing maintenance in immediate battery area or working on electrical system. Such disconnections prevent electrical shock to personnel or equipment.

REMOVAL

NOTE

Procedure is the same for both work lights.

1. REMOVE two screws (1), two lock washers (2), and GUARD (3). DISCARD lock WASHERS.
2. Disconnect electrical CONNECTOR (4) on light (5).
3. REMOVE nut (6), washer (7), spacer (8), and LIGHT (5).

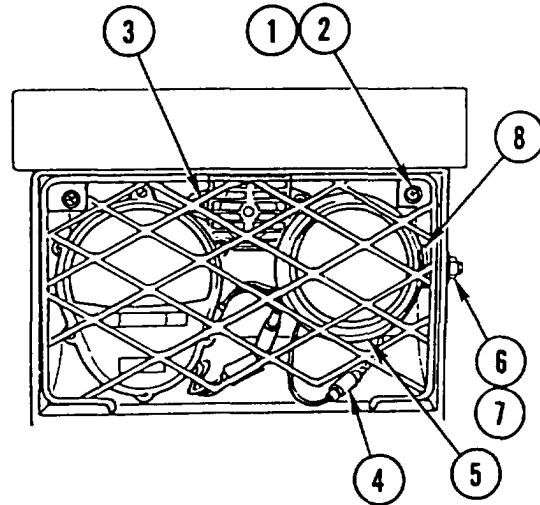

DISASSEMBLY

1. REMOVE LAMP (1) from housing (2).

NOTE

Tag wires prior to removal to aid in installation.

2. REMOVE two screws (3) and two WIRES (4) from lamp (1).

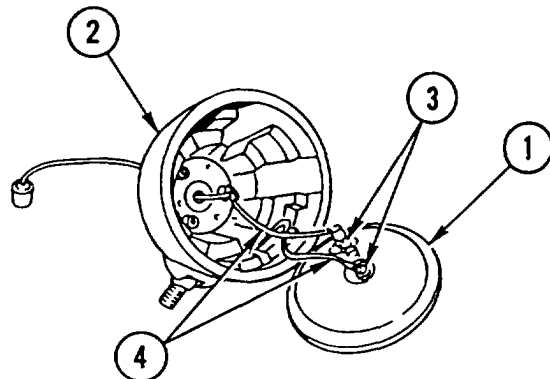

WORK LIGHT REPLACEMENT AND REPAIR (CONT)

ASSEMBLY

1. INSTALL two WIRES (4) and two screws (3) on lamp (1).
2. INSTALL LAMP (1) in housing (2).

INSTALLATION**NOTE**

Procedure is the same for both work lights.

1. INSTALL LIGHT (5), spacer (8), washer (7), and nut (6) and CONNECT electrical CONNECTOR (4).
2. INSTALL GUARD (3), two new lock washers (2), and two screws (1).

CRANE MAST FLOODLIGHT REPLACEMENT AND REPAIR

This task covers: a. Removal b. Disassembly c. Assembly d. Installation

INITIAL SETUP

Applicable Configuration:

HMMH

Tools and Special Equipment:

Tool Kit, SC 5180-90-CL-N26

General Safety Instructions:

WARNING

Remove or disconnect batteries and turn vehicle MASTER disconnect switch OFF prior to performing maintenance in immediate battery area or working on electrical system. Such disconnections prevent electrical shock to personnel or equipment.

REMOVAL

NOTE

Procedure is the same for both floodlights.

1. DISCONNECT INSULATOR (1)
2. REMOVE nut (2), washer (3), FLOODLIGHT (4), and spacer (5).

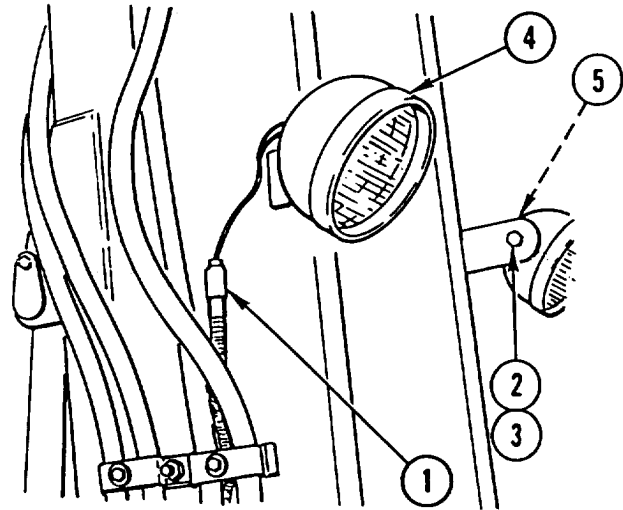

DISASSEMBLY

1. REMOVE LAMP (1) from housing (2).

NOTE

Tag wires prior to removal to aid in installation.

2. REMOVE two screws (3) and two WIRES (4) from lamp (1).

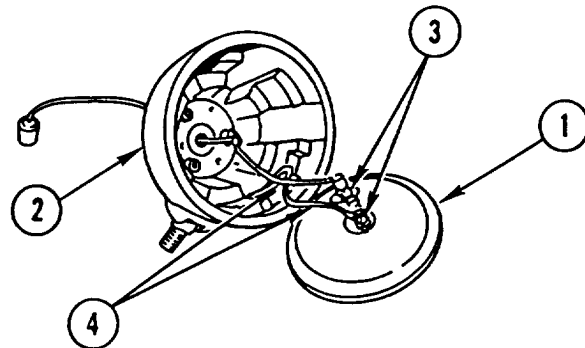

CRANE MAST FLOODLIGHT REPLACEMENT AND REPAIR (CONT)

ASSEMBLY

1. INSTALL two WIRES (4) and two screws (3) on lamp (1).
2. INSTALL LAMP (1) in housing (2).

INSTALLATION

NOTE

Procedure is the same for both floodlights.

1. INSTALL spacer (5), FLOODLIGHT (4), washer (3), and nut (2).
2. CONNECT INSULATOR (1).

REAR COMPOSITE STOPLIGHT/TAILLIGHT REPLACEMENT AND REPAIR

This task covers: a. Removal b. Disassemble c. Assembly d. Installation

INITIAL SETUP

Tools and Special Equipment:

Tool Kit, SC 5180-90-CL-N26

Materials/Parts:

Washer, Lock (2)

Packing

Washer, Lock (3)

General Safety Instructions:

WARNING

Remove or disconnect batteries and turn vehicle MASTER disconnect switch OFF prior to performing maintenance in immediate battery area or working on electrical system. Such disconnections prevent electrical shock to personnel or equipment.

REMOVAL

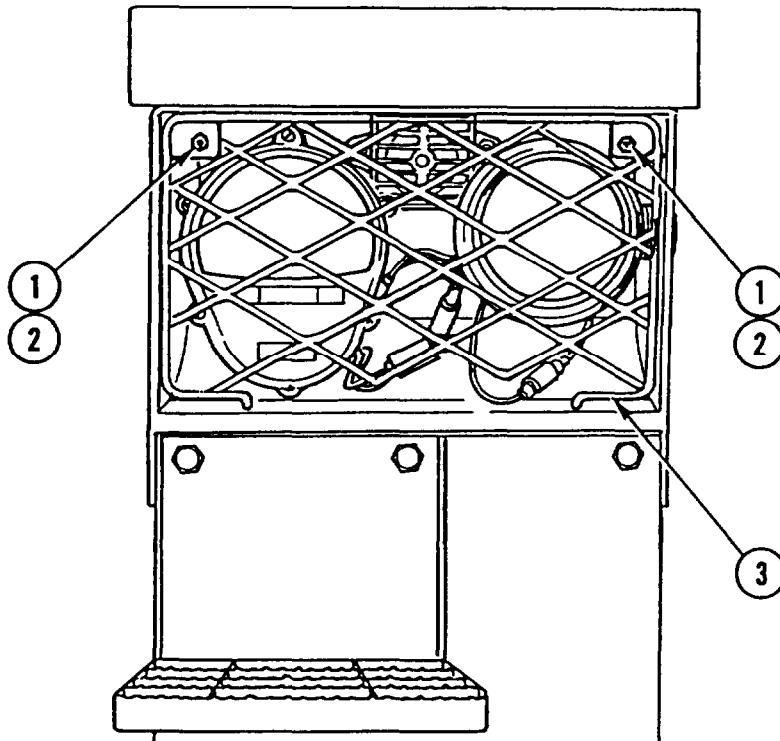

NOTE

Procedure is the same for both stoplights/taillights.

1. REMOVE two screws (1), two lock washers (2), and GUARD (3). DISCARD lock WASHERS.

**REAR COMPOSITE STOPLIGHT/TAILLIGHT REPLACEMENT AND REPAIR
(CONT)**

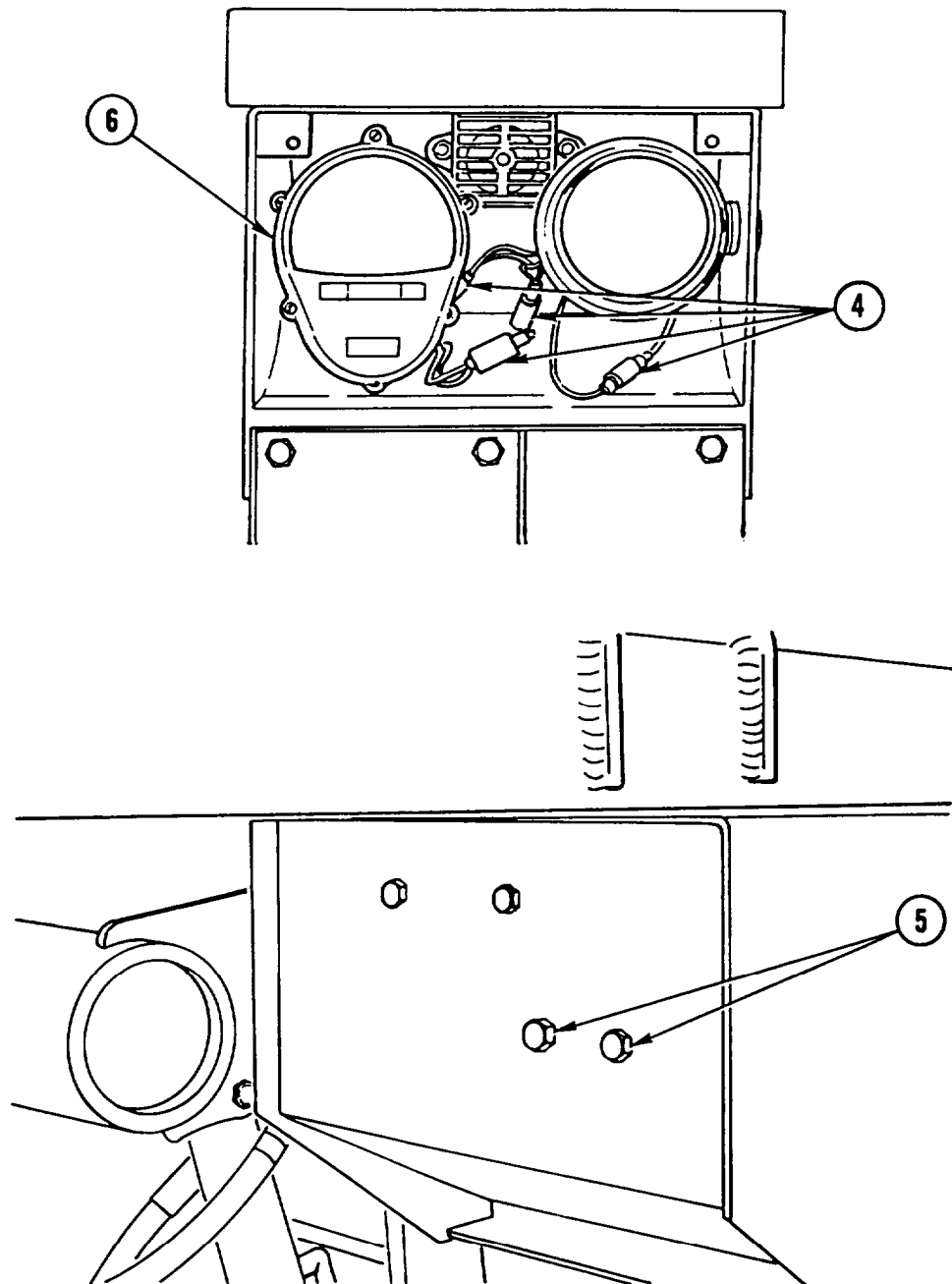
**NOTE**

Tag quick-disconnect shells prior to disconnecting to aid in connecting.

2. DISCONNECT four quick-disconnect SHELLS (4).
3. REMOVE two screws (5) and STOPLIGHT/TAILLIGHT (6).

REAR COMPOSITE STOPLIGHT/TAILLIGHT REPLACEMENT AND REPAIR (CONT)

DISASSEMBLY

NOTE

Do not remove retaining clip (1) from screw (2) unless screw is damaged.

1. LOOSEN six SCREWS (2) and REMOVE RETAINER (3) from housing (4).
2. REMOVE FILTER (5), lens (6), and packing (7). DISCARD PACKING.
3. IF DAMAGED, REMOVE INSERT (8).
4. REMOVE three SCREWS (9) and three lock washers (10). DISCARD lock WASHERS.

NOTE

Tag cables prior to disconnecting to aid in connecting.

5. DISCONNECT CABLES (11) and REMOVE two lamp HOLDERS (12 and 13), lamp HOLDER (14), and WIRING HARNESS (15).
6. REMOVE four LAMPS (16, 17, 18, and 19).
7. REMOVE four ferrules (20) and four SPRINGS (21).
8. REMOVE lamp HOLDER (12) from lamp holder (13).
9. REMOVE three bellows (22) and lamp HOLDER (14) from lamp holder (13).

ASSEMBLY

1. INSTALL lamp HOLDER (14), three bellows (22), and lamp HOLDER (12) on lamp holder (13).
2. INSTALL four SPRINGS (21) and four ferrules (20).
3. INSTALL four LAMPS (16, 17, 18, and 19).
4. INSTALL WIRING HARNESS (15), two lamp HOLDERS (12 and 13), and lamp HOLDER (14) and CONNECT CABLES (11).
5. INSTALL three new lock washers (10) and three SCREWS (9).
6. IF REMOVED, INSTALL new INSERT (8) in housing (4).
7. INSTALL new packing (7), lens (6), and FILTER (5) in retainer (3).
8. IF REMOVED, INSTALL retaining CLIP(S) (1).
9. INSTALL RETAINER (3) and six screws (2).

**REAR COMPOSITE STOPLIGHT/TAILLIGHT REPLACEMENT AND REPAIR
(CONT)**

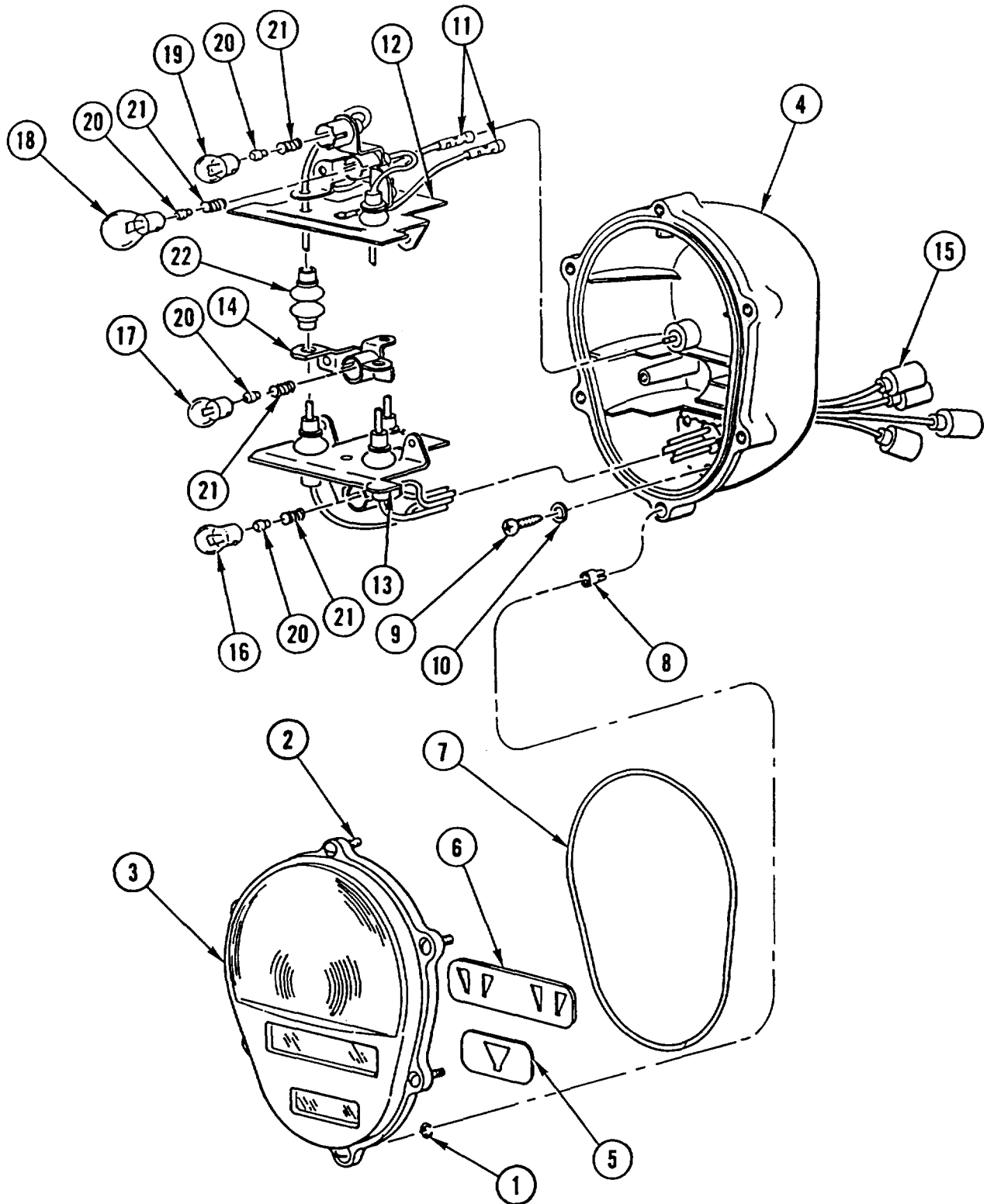

REAR COMPOSITE STOPLIGHT/TAILLIGHT REPLACEMENT AND REPAIR (CONT)

INSTALLATION

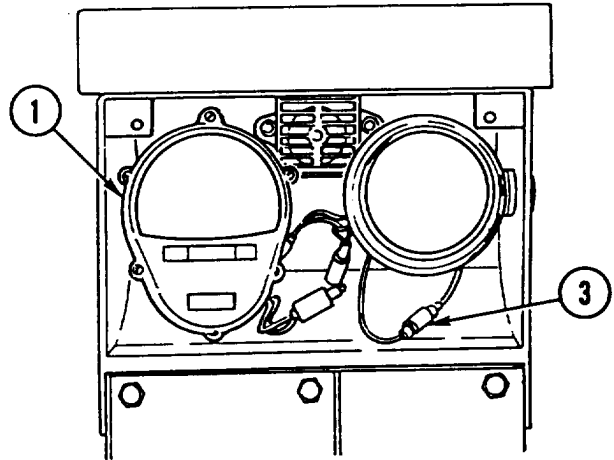

NOTE

Procedure is the same for both stoplights/taillights.

1. INSTALL STOPLIGHT/TAILLIGHT (1) and two screws (2).
2. CONNECT four quick-disconnect SHELLS (3).
3. INSTALL GUARD (4), two new lock washers (5), and two screws (6).

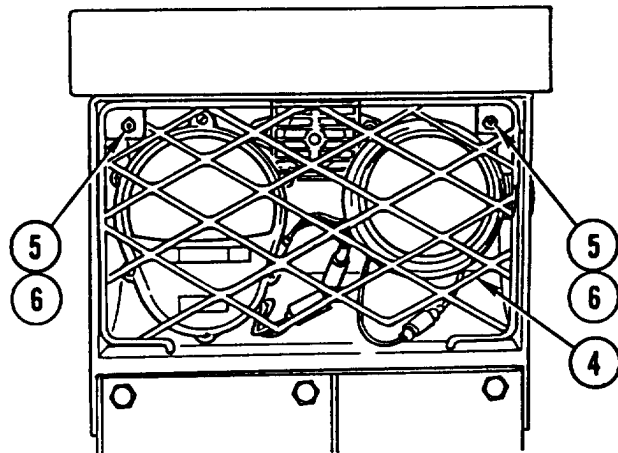
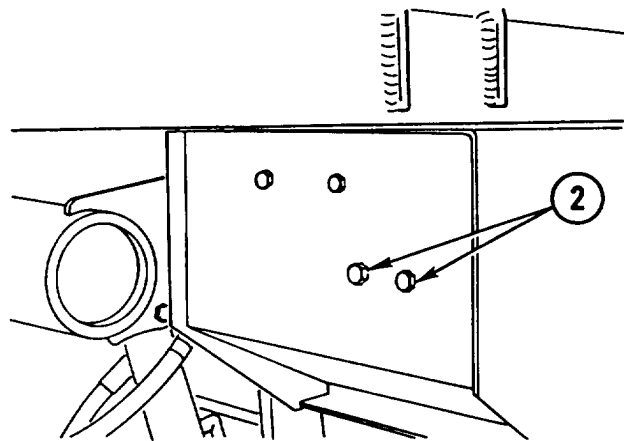

DOMES LIGHT REPLACEMENT

This task covers: a. Removal b. Installation

INITIAL SETUP

Tools and Special Equipment:

Tool Kit, SC 5180-90-CL-N26

General Safety Instructions:

WARNING

Remove or disconnect batteries and turn vehicle MASTER disconnect switch OFF prior to performing maintenance in immediate battery area or working on electrical system. Such disconnections prevent electrical shock to personnel or equipment.

REMOVAL

1. REMOVE dome LIGHT (1) by gently prying end opposite switch.

NOTE

Tag electrical connectors prior to disconnecting to aid in connecting.

2. DISCONNECT CABLE assembly (2).
3. REMOVE two LAMPS (3).

INSTALLATION

1. INSTALL two LAMPS (3).
2. CONNECT CABLE assembly (2).
3. INSTALL dome LIGHT (1).

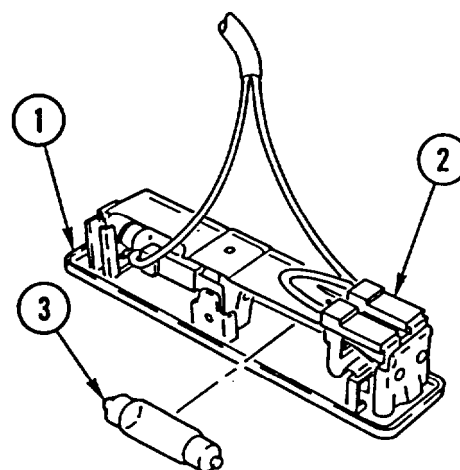
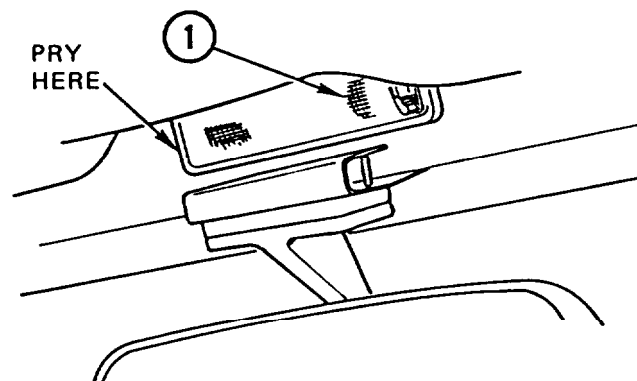

TURN SIGNAL FLASHER RELAY REPLACEMENT

This task covers: a. Removal b. Installation

INITIAL SETUP

Tools and Special Equipment:

Tool Kit, SC 5180-90-CL-N26

Materials/Parts:

Nut, Lock (2)

Personnel Required: (2)

Equipment Condition:

Reference	Condition Description
Page 4-38	Air Cleaner Ducts Removed

General Safety Instructions:

WARNING

Remove or disconnect batteries and turn vehicle MASTER disconnect switch OFF prior to performing maintenance in immediate battery area or working on electrical system. Such disconnections prevent electrical shock to personnel or equipment.

REMOVAL

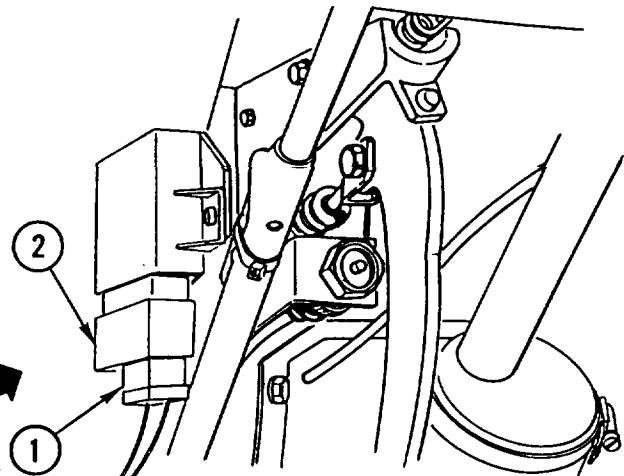
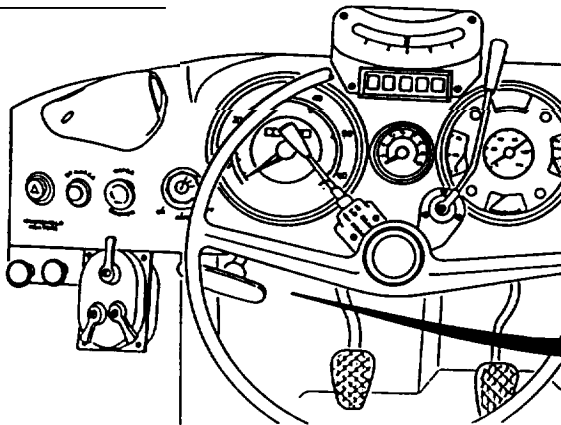

1. Disconnect CONNECTOR (1) from hybrid relay (2).
2. REMOVE lock nut (3), SCREW (4) and washer (5) and Disconnect WIRE (6) from hybrid relay (2). DISCARD lock NUT.
3. REMOVE lock nut (7), screw (8), washer (9), and hybrid RELAY (2) from angle bracket (10). DISCARD lock NUT.

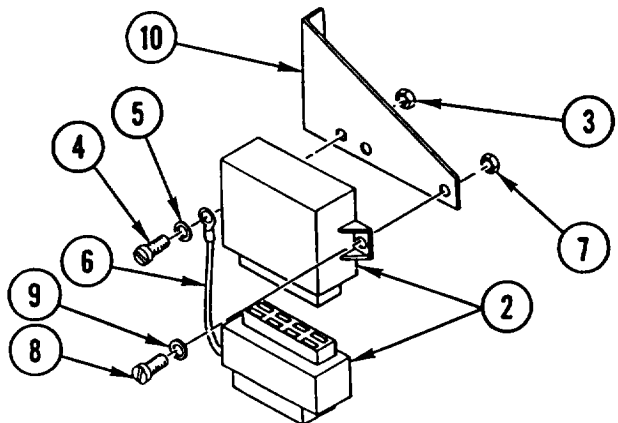

TURN SIGNAL FLASHER RELAY REPLACEMENT (CONT)

NOTE

Perform steps 4 and 5 only if angle bracket (10) is damaged.

4. WITH ASSISTANT HOLDING SCREW (11) inside cab, REMOVE NUT (12) and washer (13).

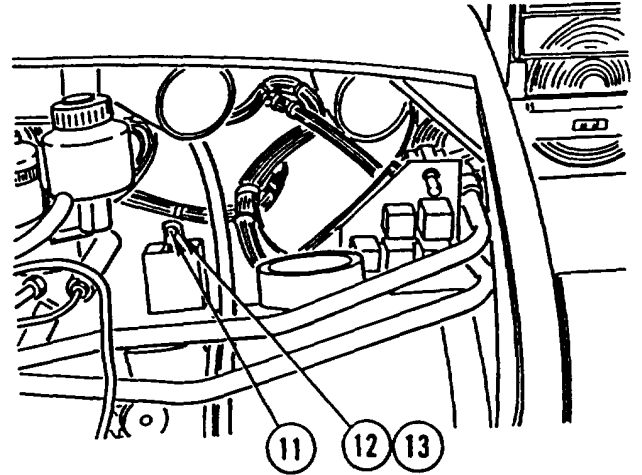

5. HAVE ASSISTANT REMOVE screw (11) and angle BRACKET (10) from fire wall (14).

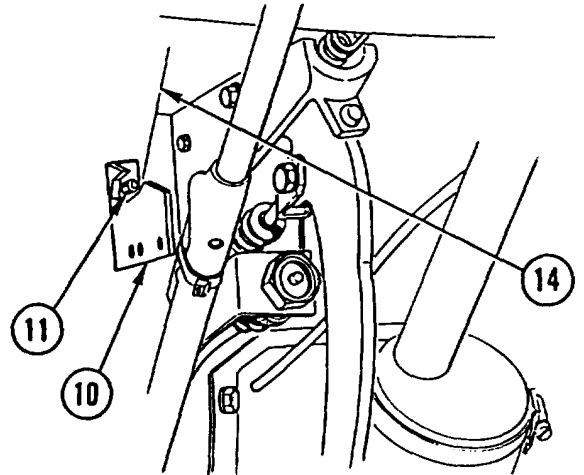

INSTALLATION

NOTE

Perform steps 1 and 2 only if angle bracket was removed.

1. HAVE ASSISTANT INSTALL new angle BRACKET (1) and screw (2) on fire wall (3).

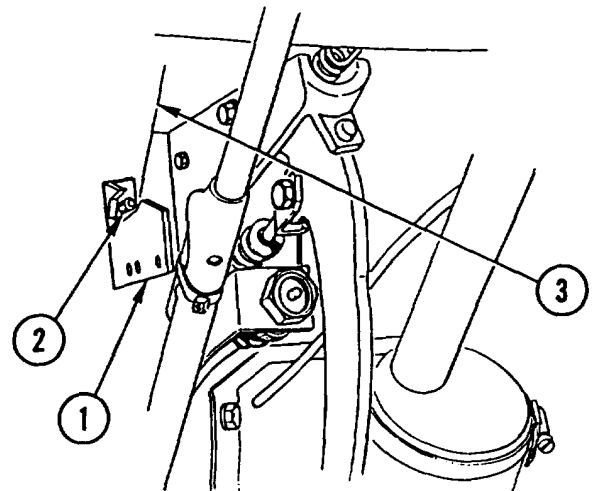

TURN SIGNAL FLASHER RELAY REPLACEMENT (CONT)

2. WITH ASSISTANT HOLDING SCREW (2) inside cab, INSTALL washer (4) and NUT (5).

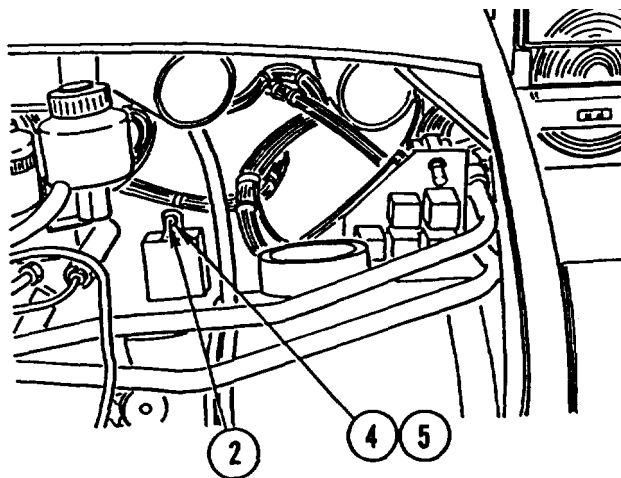

3. INSTALL washer (6), screw (7), hybrid RELAY (8), and new lock nut (9) on angle bracket (1).
4. INSTALL washer (10), screw (11), WIRE (12), and new lock nut (13) on hybrid relay (8).

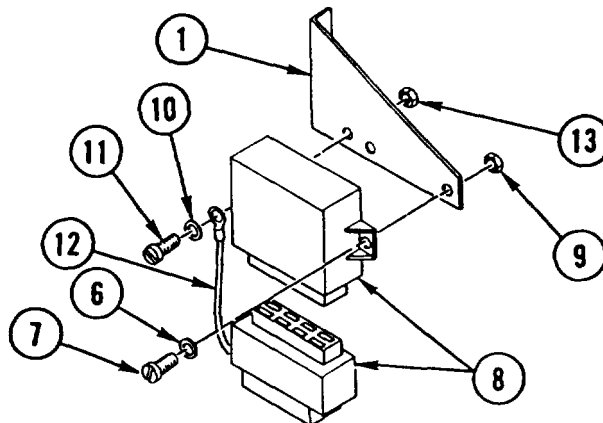

5. CONNECT CONNECTOR (14) to hybrid relay (8).

NOTE

Follow-on Maintenance:
Install air cleaner ducts (page 4-38).

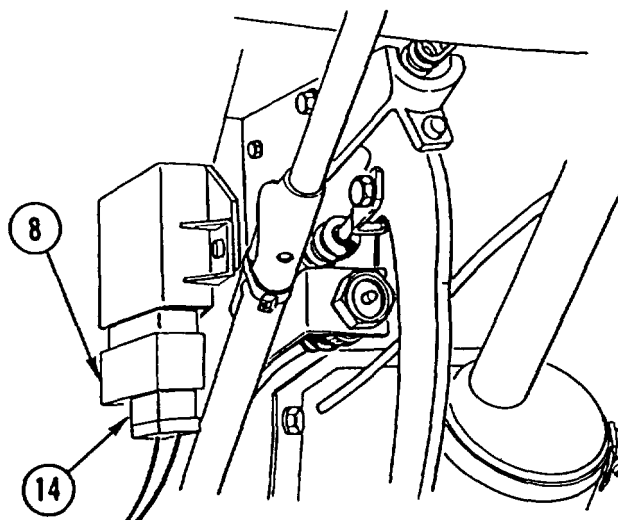

ENGINE START SWITCH REPLACEMENT

This task covers: a. Removal b. Installation

INITIAL SETUP

Tools and Special Equipment:

Tool Kit, SC 5180-90-CL-N26

General Safety Instructions:

WARNING

Remove or disconnect batteries and turn vehicle MASTER disconnect switch OFF prior to performing maintenance in immediate battery area or working on electrical system. Such disconnections prevent electrical shock to personnel or equipment.

REMOVAL

1. REMOVE nut (1) and engine start SWITCH (2) from bracket (3).
2. DISCONNECT electrical CONNECTOR (4).

INSTALLATION

1. CONNECT electrical CONNECTOR (4).
2. INSTALL engine start SWITCH (2) and nut (1) on bracket (3).

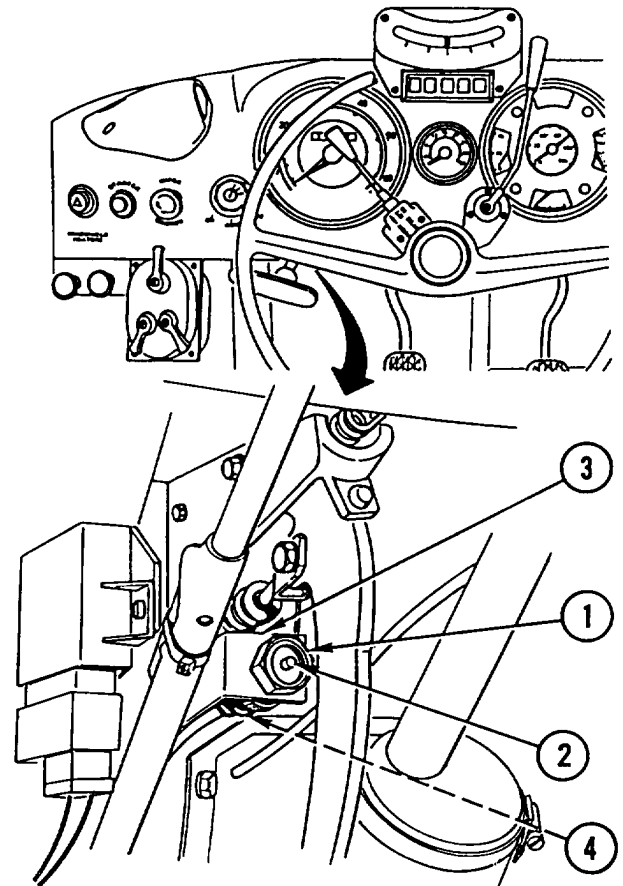

BRAKE LIGHT SWITCH REPLACEMENT

This task covers: a. Removal b. Installation

INITIAL SETUP

Tools and Special Equipment:

Tool Kit, SC 5180-90-CL-N26

General Safety Instructions:

WARNING

Remove or disconnect batteries and turn vehicle MASTER disconnect switch OFF prior to performing maintenance in immediate battery area or working on electrical system. Such disconnections prevent electrical shock to personnel or equipment.

REMOVAL

1. DISCONNECT CONNECTOR (1) from brake light switch (2).
2. WITH BRAKE PEDAL DEPRESSED, REMOVE rubber bumper (3), nut (4), and SWITCH (2).

INSTALLATION

1. WITH BRAKE PEDAL DEPRESSED, INSTALL brake light SWITCH (2), nut (4), and rubber bumper (3).
2. CONNECT CONNECTOR (1) to switch (2).

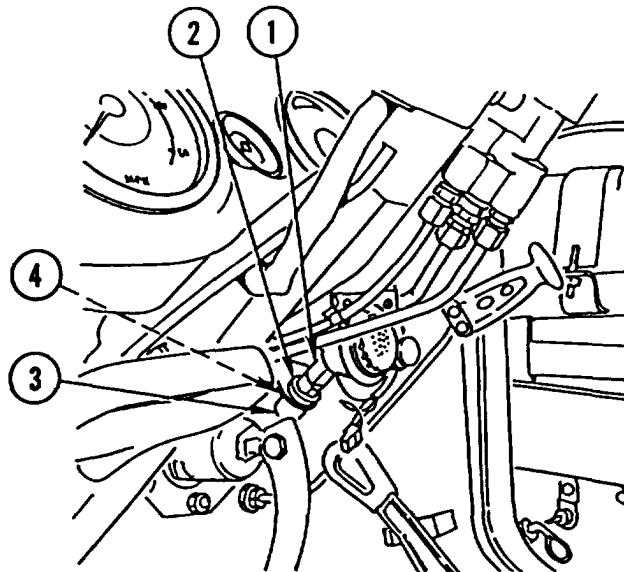

STARTER LOCKOUT/INTERMEDIATE SPEED SHIFT SENDING UNIT REPLACEMENT

This task covers: a. Removal b. Installation

INITIAL SETUP

Tools and Special Equipment:

Tool Kit, SC 5180-90-CL-N26

General Safety Instructions:

WARNING

Remove or disconnect batteries and turn vehicle MASTER disconnect switch OFF prior to performing maintenance in immediate battery area or working on electrical system. Such disconnections prevent electrical shock to personnel or equipment.

REMOVAL

1. Disconnect electrical CONNECTOR (1) from sending unit (2).
2. REMOVE sending UNIT (2).

INSTALLATION

1. INSTALL sending UNIT (2).
2. CONNECT electrical CONNECTOR (1) to sending unit (2).

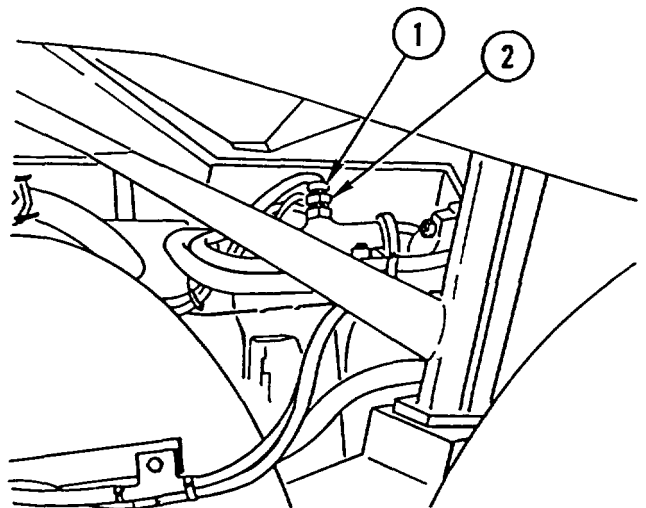

OIL PRESSURE SENDER REPLACEMENT

This task covers: a. Removal b. Installation

INITIAL SETUP

Tools and Special Equipment:

Tool Kit, SC 5180-90-CL-N26

Equipment Condition:

Reference

Page 4-389

Condition Description

Inside Engine Hood
Removed

General Safety Instructions:

WARNING

Remove or disconnect batteries and turn vehicle MASTER disconnect switch OFF prior to performing maintenance in immediate battery area or working on electrical system. Such disconnections prevent electrical shock to personnel or equipment.

REMOVAL

NOTE

Tag wires prior to removal to aid in installation.

1. REMOVE two nuts (1) and two WIRES (2).
2. REMOVE oil pressure SENDER (3).

INSTALLATION

1. INSTALL oil pressure SENDER (3).
2. INSTALL two WIRES (2) and two nuts (1).

NOTE

Follow-on Maintenance:
Install inside engine hood (page 4-389).

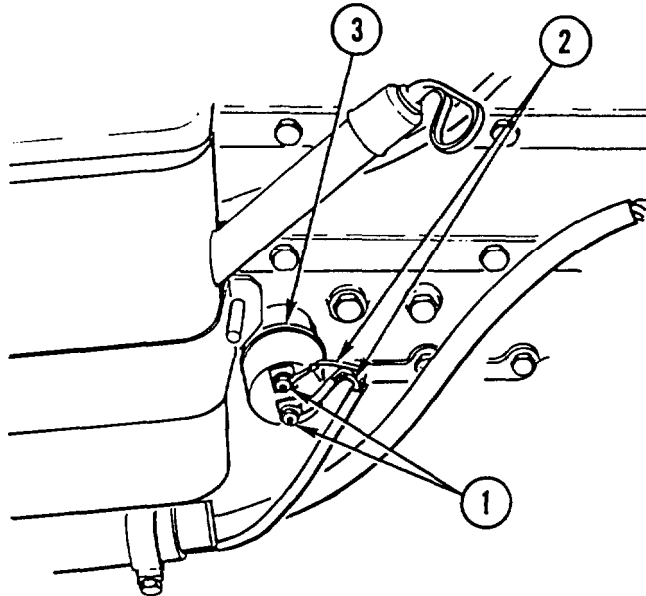

WATER TEMPERATURE SENDING UNIT REPLACEMENT

This task covers: a. Removal b. Installation

INITIAL SETUP

Tools and Special Equipment:

Tool Kit, SC 5180-90-CL-N26

Materials/Parts:

Ring, Seal

Equipment Condition:

Reference	Condition Description
Page 4-388	Outside Engine Hood Removed
Page 4-87	Cooling System Drained

General Safety Instructions:

WARNING

Remove or disconnect batteries and turn vehicle MASTER disconnect switch OFF prior to performing maintenance in immediate battery area or working on electrical system. Such disconnections prevent electrical shock to personnel or equipment.

REMOVAL

1. DISCONNECT two CONNECTORS (1).
2. REMOVE water temperature SENDING UNIT (2) and seal ring (3). DISCARD seal RING.

INSTALLATION

1. INSTALL water temperature SENDING UNIT (2) and new seal ring (3).
2. CONNECT two CONNECTORS (1)

NOTE

Follow-on Maintenance:
 Fill cooling system (page 4-87).
 Install outside engine hood (page 4-388).

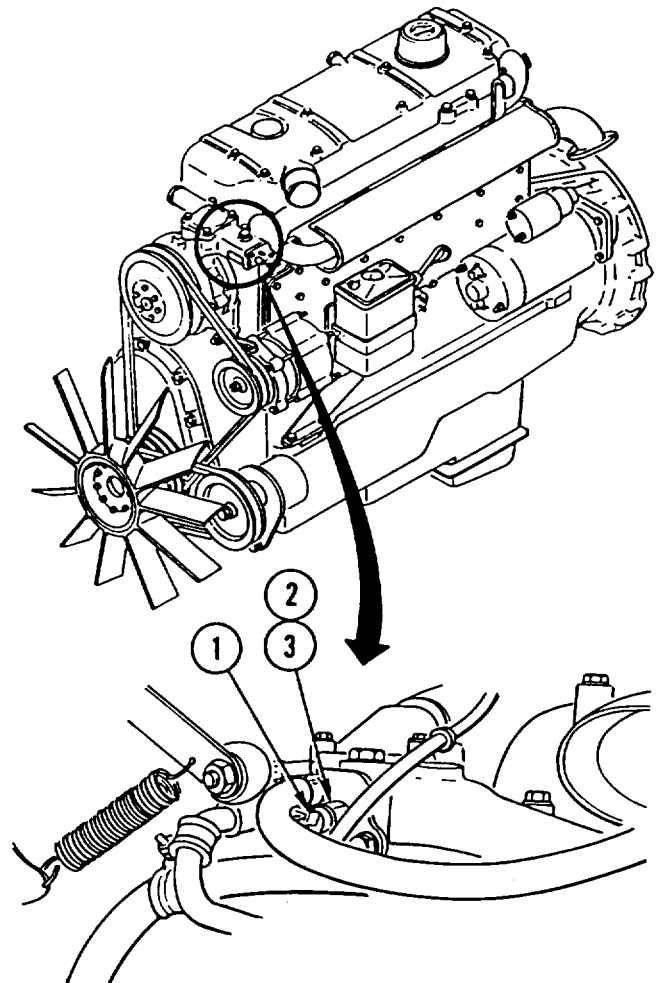

FUEL LEVEL GAGE REPLACEMENT

This task covers: a. Removal b. Installation

INITIAL SETUP

Tools and Special Equipment:

Tool Kit, SC 5180-90-CL-N26

Materials/Parts:

Seal (5)

Gasket

Personnel Required: (2)

Equipment Condition:

Reference	Condition Description
Page 4-40	Fuel Tank Drained

General Safety Instructions:

WARNING

Remove or disconnect batteries and turn vehicle MASTER disconnect switch OFF prior to performing maintenance in immediate battery area or working on electrical system. Such disconnections prevent electrical shock to personnel or equipment.

REMOVAL

1. LOOSEN two NUTS (1).
2. SLIDE fuel TANK (2) forward and LOOSEN two hose clamp SCREWS (3).

NOTE

Tag lines prior to removal to aid in installation.

3. REMOVE two HOSES (4), nut (5), and electrical CONNECTOR (6).
4. REMOVE five screws (7), five seals (8), fuel level GAGE (9), and gasket (10). DISCARD SEALS and GASKET.

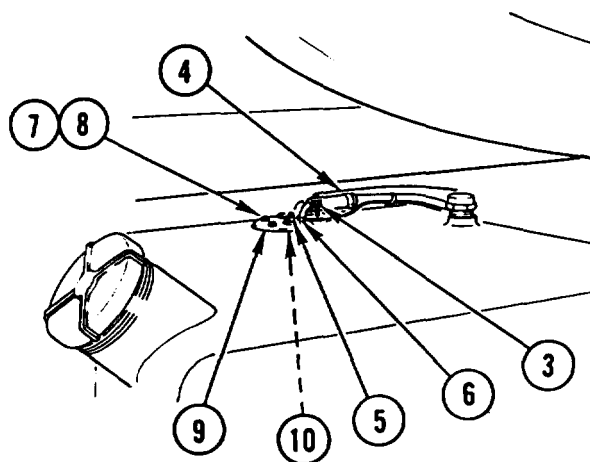
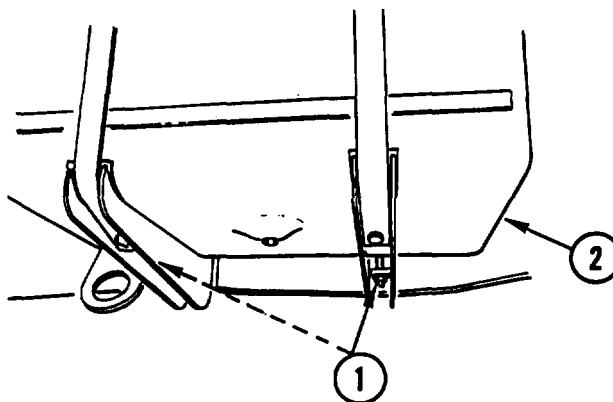

INSTALLATION

1. INSTALL new gasket (10), fuel level GAGE (9), five new seals (8), and five screws (7).
2. INSTALL electrical CONNECTOR (6), nut (5), and two HOSES (4). TIGHTEN two hose clamp SCREWS (3).
3. SLIDE fuel TANK (2) BACK in place and TIGHTEN two NUTS (1).

NOTE

Follow-on Maintenance:
Fill fuel tank (page 4-40).

AIR CLEANER RESTRICTOR INDICATOR SWITCH REPLACEMENT

This task covers: a. Removal b. Installation

INITIAL SETUP

Tools and Special Equipment:

Tool Kit, SC 5180-90-CL-N26

General Safety Instructions:

WARNING

Remove or disconnect batteries and turn vehicle MASTER disconnect switch OFF prior to performing maintenance in immediate battery area or working on electrical system. Such disconnections prevent electrical shock to personnel or equipment.

REMOVAL

NOTE

Tag wires prior to disconnecting to aid in connecting.

DISCONNECT two WIRES (1 and 2) and REMOVE air cleaner restrictor indicator SWITCH (3).

INSTALLATION

INSTALL air cleaner restrictor indicator SWITCH (3) and CONNECT two WIRES (1 and 2).

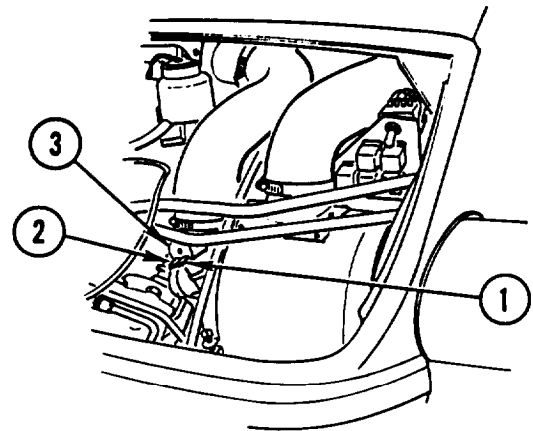

POWER TAKE-OFF INDICATOR SWITCH REPLACEMENT

This task covers: a. Removal b. Installation

INITIAL SETUP

Tools and Special Equipment:

Tool Kit, SC 5180-90-CL-N26

Equipment Condition:

Reference	Condition Description
Page 4-418	Cab Tilted

General Safety Instructions:

WARNING

Remove or disconnect batteries and turn vehicle MASTER disconnect switch OFF prior to performing maintenance in immediate battery area or working on electrical system. Such disconnections prevent electrical shock to personnel or equipment.

REMOVAL

1. DISCONNECT electrical CONNECTOR (1) from Power Take-Off indicator switch (2).
2. REMOVE Power Take-Off indicator SWITCH (2) from Power Take-Off (3).

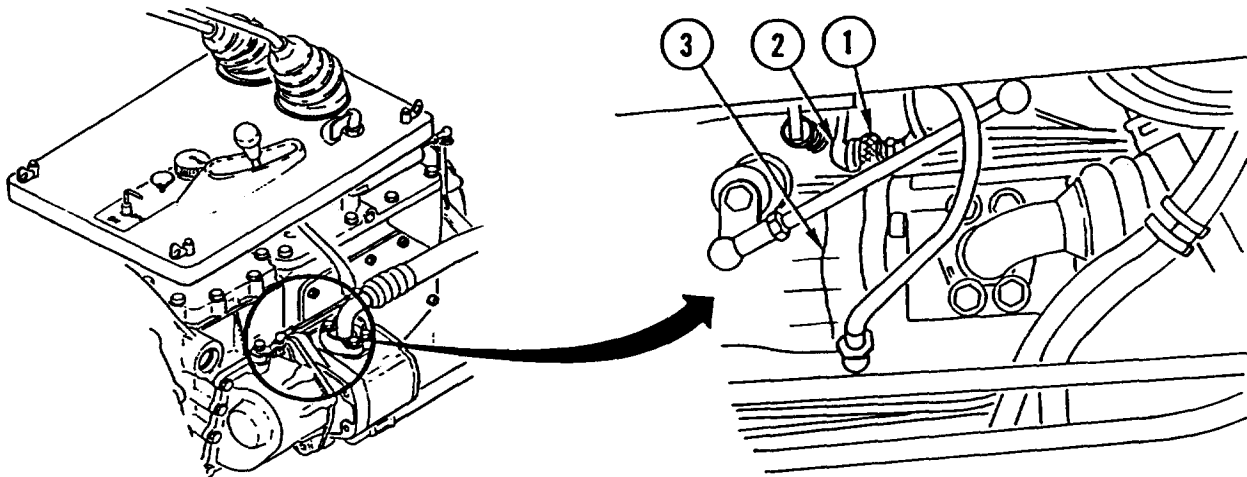

INSTALLATION

1. INSTALL Power Take-Off indicator SWITCH (2) on Power Take-Off (3).
2. CONNECT electrical CONNECTOR (1) to Power Take-Off indicator switch (2).

NOTE

Follow-on Maintenance:

Lower cab (page 4-418).

DIFFERENTIAL LOCK INDICATOR SWITCH REPLACEMENT

This task covers: a. Removal b. Installation

INITIAL SETUP

Tools and Special Equipment:

Tool Kit, SC 5180-90-CL-N26

Equipment Condition:

Reference	Condition Description
Page 4-390 or 4-391	Spare Tire and Mount Removed

General Safety Instructions:

WARNING

Remove or disconnect batteries and turn vehicle MASTER disconnect switch OFF prior to performing maintenance in immediate battery area or working on electrical system. Such disconnections prevent electrical shock to personnel or equipment.

REMOVAL

1. DISCONNECT electrical CONNECTOR (1).
2. REMOVE differential lock indicator SWITCH (2).

INSTALLATION

1. INSTALL differential lock indicator SWITCH (2).
2. CONNECT electrical CONNECTOR (1).

NOTE

Follow-on Maintenance:
Install spare tire and mount (page 4-390 or 4-391).

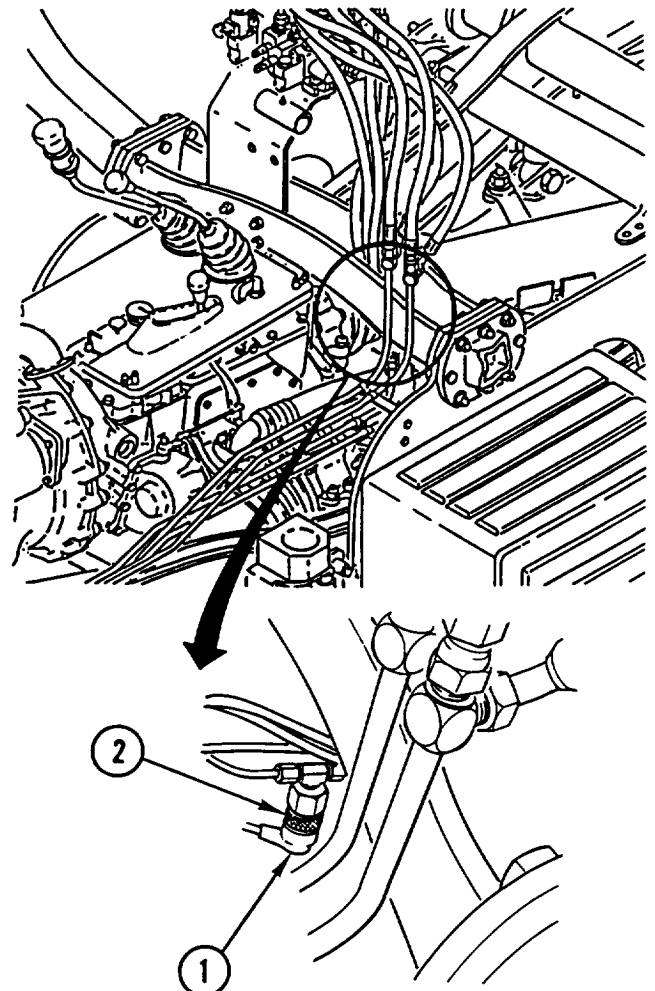

BACKUP ALARM SWITCH REPLACEMENT

This task covers: a. Removal b. Installation

INITIAL SETUP

Tools and Special Equipment:

Tool Kit, SC 5180-90-CL-N26

Equipment Condition:

Reference	Condition Description
Page 4-418	Cab Tilted

General Safety Instructions:

WARNING

Remove or disconnect batteries and turn vehicle MASTER disconnect switch OFF prior to performing maintenance in immediate battery area or working on electrical system. Such disconnections prevent electrical shock to personnel or equipment.

REMOVAL

1. CAREFULLY ROLL BACK rubber COVER (1) and DISCONNECT electrical CONNECTOR (2).
2. REMOVE backup alarm SWITCH (3).

INSTALLATION

1. INSTALL backup alarm SWITCH (3).
2. CONNECT electrical CONNECTOR (2) and CAREFULLY ROLL rubber COVER (1) BACK in place.

NOTE

Follow-on Maintenance:
Lower cab (page 4-418).

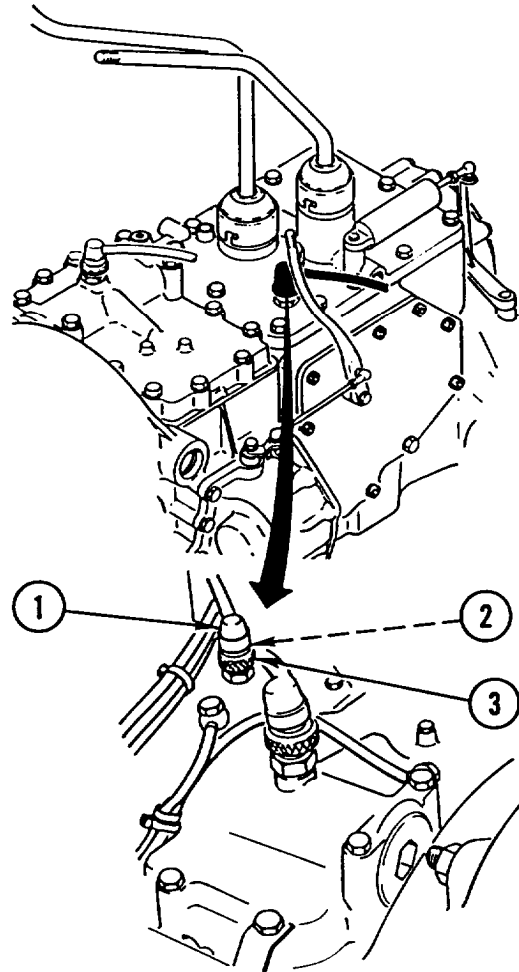

INTERMEDIATE SPEED SHIFT AND INDICATOR SWITCH REPLACEMENT

This task covers: a. Removal b. Installation

INITIAL SETUP

Tools and Special Equipment:

Tool Kit, SC 5180-90-CL-N26

Equipment Condition:

Reference	Condition Description
Page 4-418	Cab Tilted

General Safety Instructions:

WARNING

Remove or disconnect batteries and turn vehicle MASTER disconnect switch OFF prior to performing maintenance in immediate battery area or working on electrical system. Such disconnections prevent electrical shock to personnel or equipment.

REMOVAL

1. CAREFULLY ROLL BACK rubber COVER (1) and DISCONNECT electrical CONNECTOR (2).
2. REMOVE intermediate speed shift and indicator SWITCH (3).

INSTALLATION

1. INSTALL intermediate speed shift and indicator SWITCH (3).
2. CONNECT electrical CONNECTOR (2) and CAREFULLY ROLL rubber COVER (1) BACK in place.

NOTE

Follow-on Maintenance:
Lower cab (page 4-418).

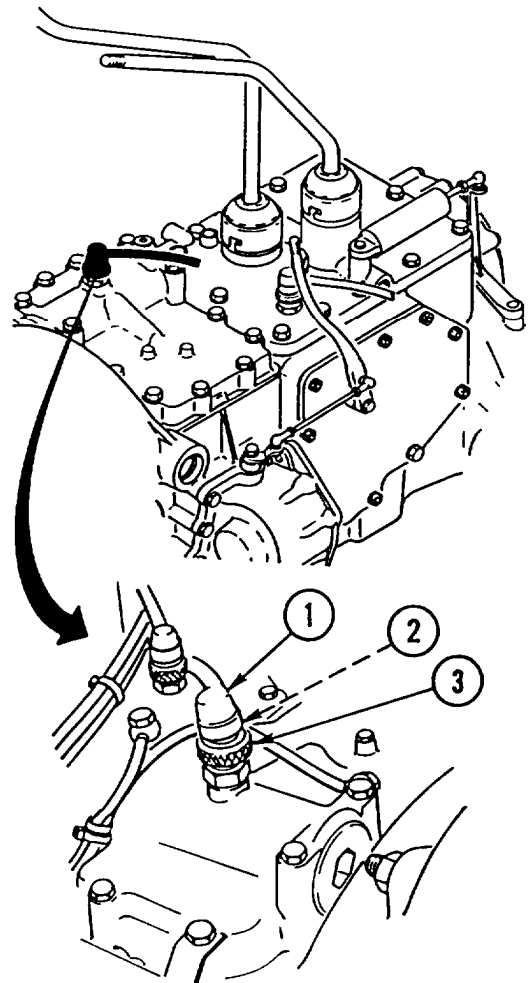

PARKING BRAKE SWITCH REPLACEMENT

This task covers: a. Removal b. Installation

INITIAL SETUP

Tools and Special Equipment:

Tool Kit, SC 5180-90-CL-N26

General Safety Instructions:

WARNING

Remove or disconnect batteries and turn vehicle MASTER disconnect switch OFF prior to performing maintenance in immediate battery area or working on electrical system. Such disconnections prevent electrical shock to personnel or equipment.

REMOVAL

1. DISCONNECT electrical CONNECTOR (1).
2. REMOVE nut (2), washer (3), and parking brake SWITCH (4).

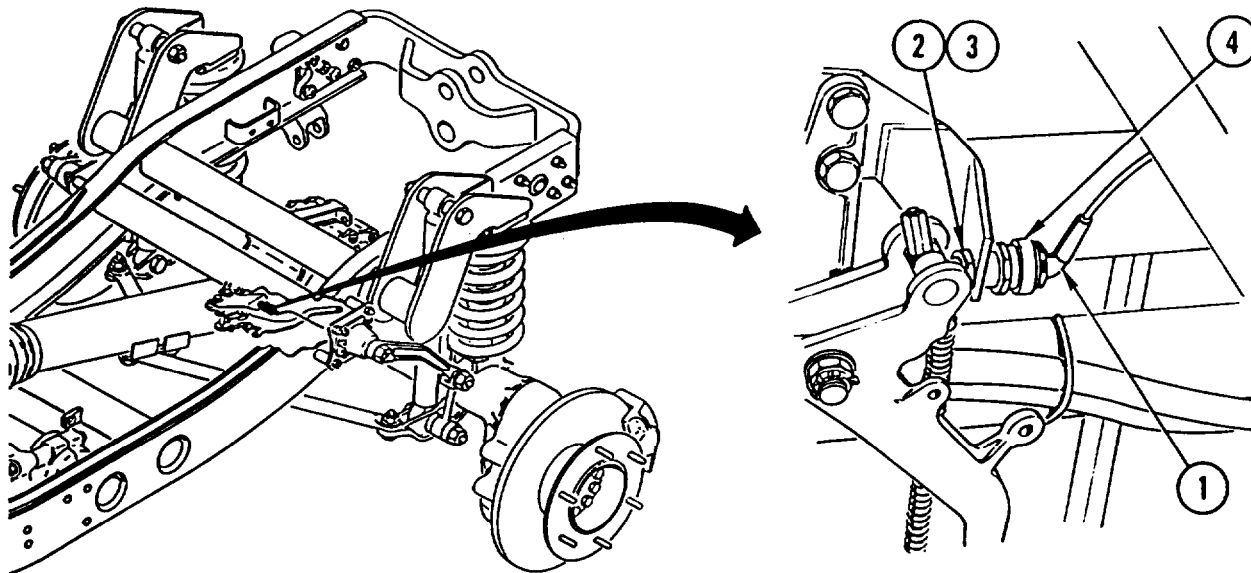

INSTALLATION

1. INSTALL parking brake SWITCH (4), washer (3), and nut (2).
2. CONNECT electrical CONNECTOR (1).
3. ADJUST parking brake SWITCH (4) so that cab light will come on only when parking brake is applied.

STE/ICE-R RESISTOR REPLACEMENT

This task covers: a. Removal b. Installation

INITIAL SETUP

Tools and Special Equipment:

Tool Kit, SC 5180-90-CL-N26

Equipment Condition:

Reference	Condition Description
Page 4-418	Cab Tilted

General Safety Instructions:

WARNING

Remove or disconnect batteries and turn vehicle MASTER disconnect switch OFF prior to performing maintenance in immediate battery area or working on electrical system. Such disconnections prevent electrical shock to personnel or equipment.

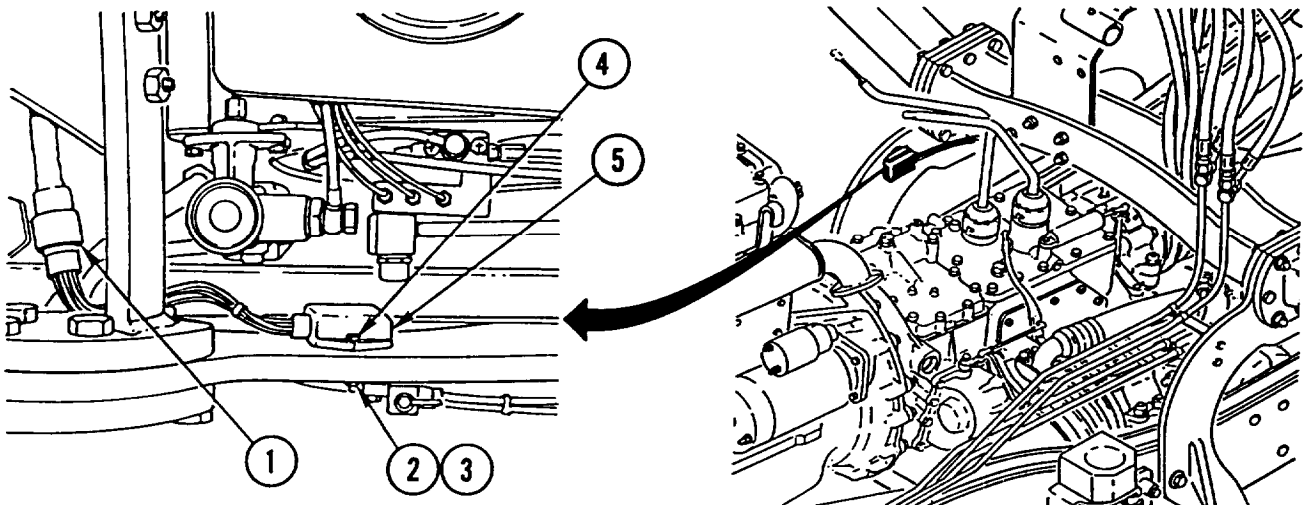

REMOVAL

1. Disconnect CONNECTOR (1).
REMOVE nut (2), washer (3), bolt (4), and STE/ICE-R RESISTOR (5).

INSTALLATION

1. INSTALL STE/ICE-R RESISTOR (5), bolt (4), washer (3), and nut (2).
2. CONNECT CONNECTOR (1).

NOTE

Follow-on Maintenance:

Lower cab (page 4-418).

STE/ICE-R FUEL PRESSURE SWITCH REPLACEMENT

This task covers: a. Removal b. Installation

INITIAL SETUP

Tools and Special Equipment:

Shop Equipment, SC 4910-95-CL-A74
 Tool Kit, SC 5180-90-CL-N26

Materials/Parts:

Rags Appendix C, Item 32

References:

TM 5-2420-224-10

Equipment Condition:

Reference	Condition Description
TM 5-2420-224-10	Fuel Shutoff Valve Closed
Page 4-388	Outside Engine Hood Removed

General Safety Instructions:

WARNING

- Diesel fuel is flammable. Do not perform this procedure near fire, flame, or sparks. Injury or death to personnel could result.
- Fuel and oil are slippery and can cause falls. To avoid injury, wipe up spilled fuel or oil with rags.

REMOVAL

NOTE

Have container available to catch any fuel in fuel lines.

LOOSEN two ADAPTERS (1) and REMOVE fuel pressure SWITCH (2).

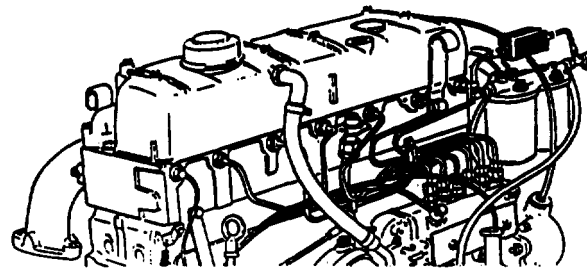

INSTALLATION

INSTALL fuel pressure SWITCH (2) and TIGHTEN two ADAPTERS (1).

NOTE

Follow-on Maintenance:

Open fuel shutoff valve (TM 5-2420-224-10).
 Install outside engine hood (page 4-388).

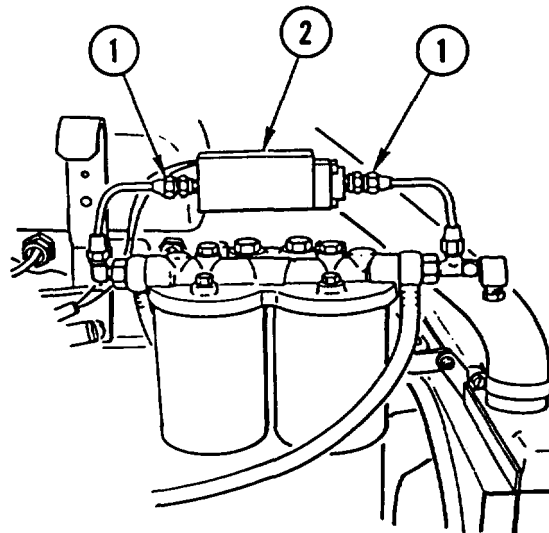

STE/ICE-R SHUNT REPLACEMENT

This task covers: a. Removal b. Installation

INITIAL SETUP

Tools and Special Equipment:

Tool Kit, SC 5180-90-CL-N26

Equipment Condition:

Reference	Condition Description
Page 4-219	Batteries Removed
Page 4-390 or 4-391	Spare Tire and Mount Removed

REMOVAL

NOTE

Tag wires prior to disconnecting to aid in connecting.

1. REMOVE two SCREWS (1) and two washers (2) and Disconnect two WIRES (3) from shunt (4).
2. REMOVE two SCREWS (5) and two washers (6) and Disconnect two CABLES (7) from shunt (4).
3. REMOVE two nuts (8), two screws (9), and SHUNT (4) from battery box (10).

INSTALLATION

1. INSTALL SHUNT (4), two screws (9), and two nuts (8) on battery box (10).
2. CONNECT two CABLES (7) and INSTALL two washers (6) and two SCREWS (5) on shunt (4).
3. CONNECT two WIRES (3) and INSTALL two washers (2) and two SCREWS (1) on shunt (4).

NOTE

Follow-on Maintenance:

Install spare tire and mount (page 4-390 or 4-391).

Install batteries (page 4-219).

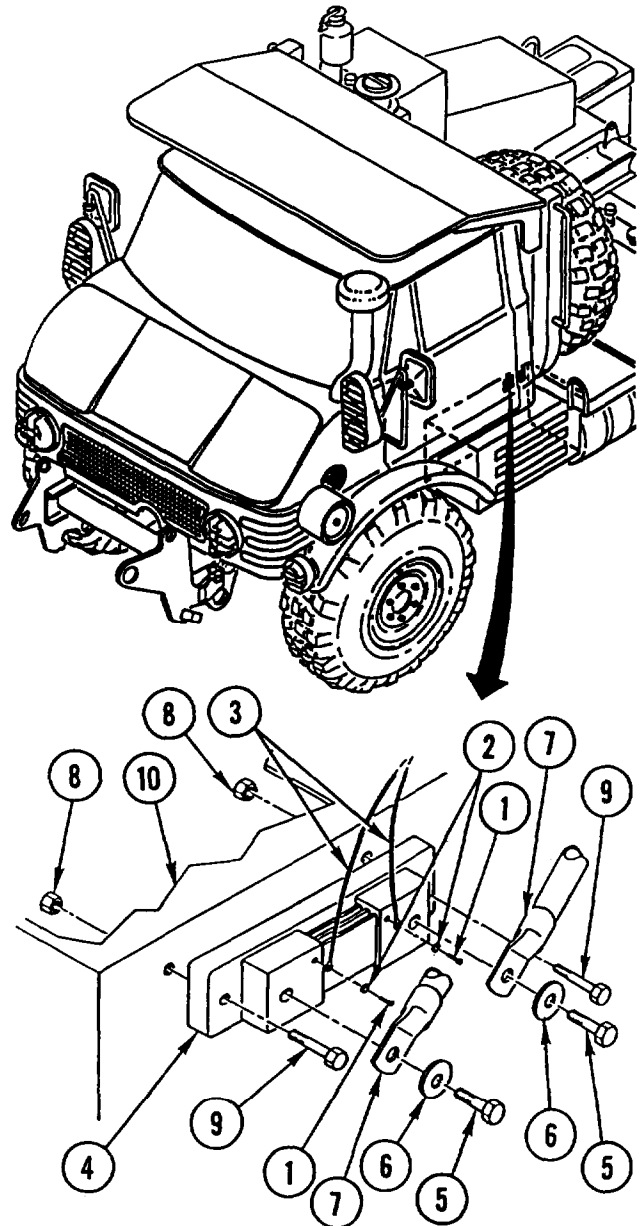

BACKUP ALARM REPLACEMENT

This task covers: a. Removal b. Installation

INITIAL SETUP

Tools and Special Equipment:

Tool Kit, SC 5180-90-CL-N26

Materials/Parts:

Washer, Lock (2)

General Safety Instructions:

WARNING

Remove or disconnect batteries and turn vehicle MASTER disconnect switch OFF prior to performing maintenance in immediate battery area or working on electrical system. Such disconnections prevent electrical shock to personnel or equipment.

REMOVAL

1. REMOVE two screws (1), two lock washers (2), and GUARD (3). DISCARD lock WASHERS.

NOTE

Tag wires prior to removal to aid in installation.

2. CAREFULLY ROLL BACK rubber BOOTS and REMOVE two nuts (4) and two WIRES (5).
3. REMOVE two screws (6), two nuts (7), and ALARM (8).

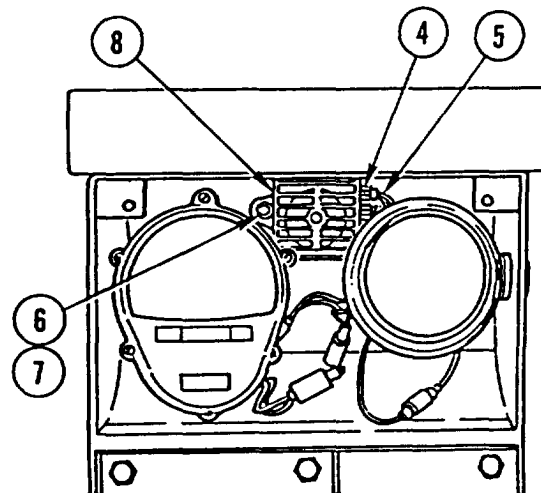
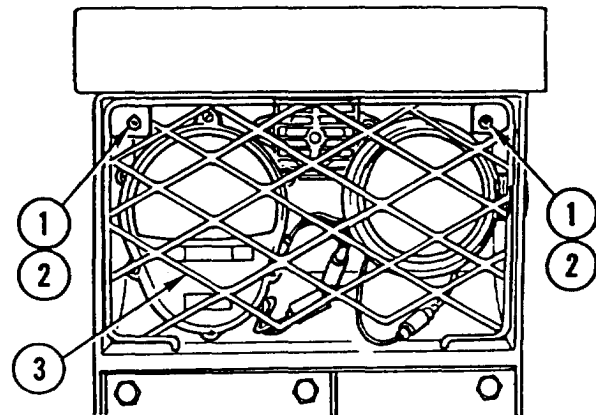

INSTALLATION

1. INSTALL ALARM (8), two screws (6), and two nuts (7).
2. INSTALL two WIRES (5) and two nuts (4) and CAREFULLY ROLL rubber BOOTS over connection.
3. INSTALL GUARD (3), two new lock washers (2), and two screws (1).

HORN, LOW BEAM/HIGH BEAM SWITCH REPLACEMENT

This task covers: a. Removal b. Installation

INITIAL SETUP

Tools and Special Equipment:

Tool Kit, SC 5180-90-CL-N26

Equipment Condition:

Reference	Condition Description
Page 4-388	Outside Engine Hood Removed
Page 4-166	Fuse Holders Removed
Page 4-38	Air Cleaner Ducts Removed

General Safety Instructions:

WARNING

Remove or disconnect batteries and turn vehicle MASTER disconnect switch OFF prior to performing maintenance in immediate battery area or working on electrical system. Such disconnections prevent electrical shock to personnel or equipment.

REMOVAL

1. DISCONNECT CONNECTOR (1).

NOTE

Tag wires prior to removal to aid in installation.

2. REMOVE five WIRES (2) from connector (1).
3. PULL WIRING HARNESS (3) THROUGH underside of dashboard (4).

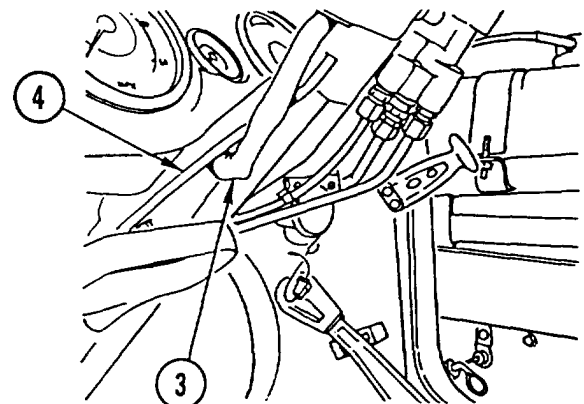
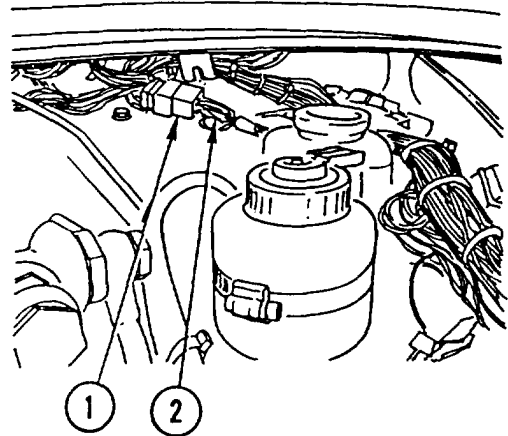

HORN, LOW BEAM/HIGH BEAM SWITCH REPLACEMENT (CONT)

4. REMOVE two screws (5) and horn, low beam/high beam SWITCH (6).

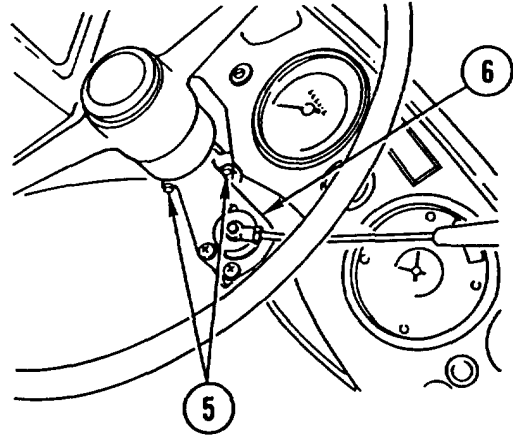

INSTALLATION

1. INSTALL horn, low beam/high beam SWITCH (1) and two screws (2).

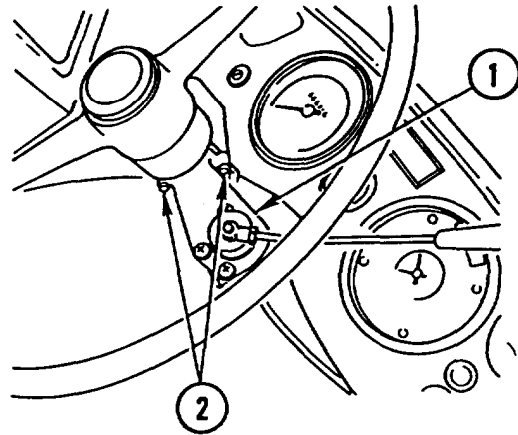

HORN, LOW BEAM/HIGH BEAM SWITCH REPLACEMENT (CONT)

2. PUSH WIRING HARNESS (3) THROUGH underside of dashboard (4).

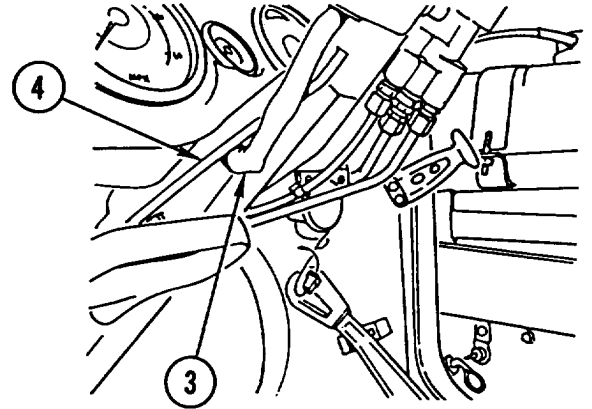

3. INSTALL five WIRES (5) in connector (6).
4. CONNECT CONNECTOR (6).

NOTE

Follow-on Maintenance:

Install air cleaner ducts (page 4-38).

Install fuse holders (page 4-166).

Install outside engine hood (page 4-388).

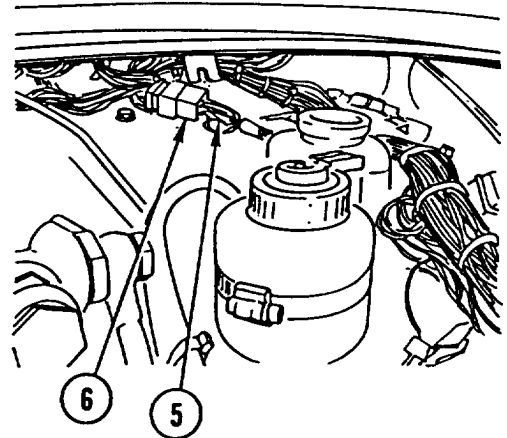

HORN REPLACEMENT

This task covers: a. Removal b. Installation

INITIAL SETUP

Tools and Special Equipment:

Tool Kit, SC 5180-90-CL-N26

Materials/Parts:

Washer, Lock (2)

Washer, Lock

General Safety Instructions:

WARNING

Remove or disconnect batteries and turn vehicle MASTER disconnect switch OFF prior to performing maintenance in immediate battery area or working on electrical system. Such disconnections prevent electrical shock to personnel or equipment.

REMOVAL

NOTE

Tag wires prior to disconnecting to aid in connecting.

1. REMOVE two SCREWS (1) and two lock washers (2) and DISCONNECT two WIRES (3) from horn (4). DISCARD lock WASHERS.
2. REMOVE nut (5), lock washer (6), and HORN (4). DISCARD lock WASHER.

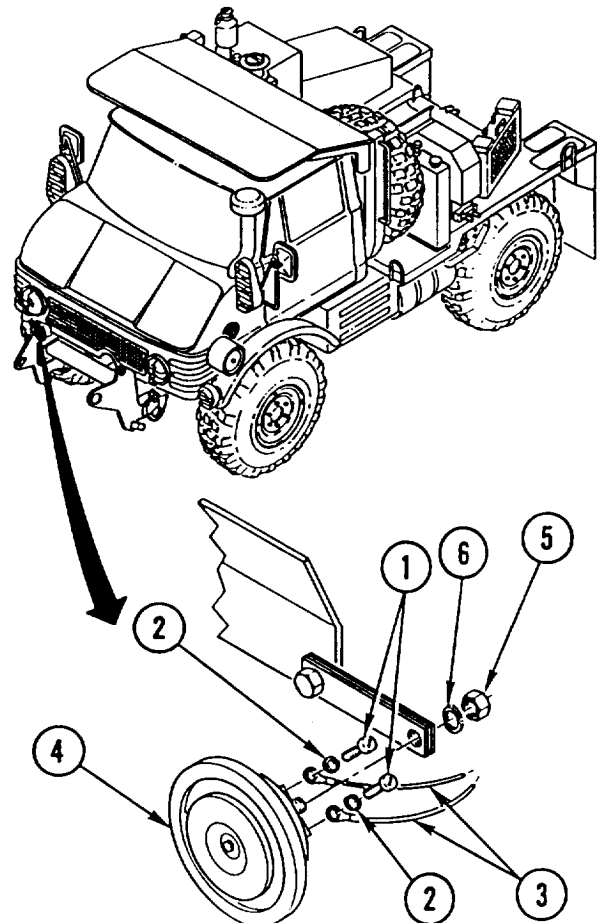

INSTALLATION

1. INSTALL HORN (4), new lock washer (6), and nut (5).
2. CONNECT two WIRES (3) to horn (4) and INSTALL two SCREWS (1) and two new lock washers (2).

BATTERY REPLACEMENT

This task covers: a. Removal b. Service c. Installation

INITIAL SETUP

Tools and Special Equipment:

Shop Equipment, SC 4910-95-CL-A74
 Tool Kit, SC 5180-90-CL-N26

Materials/Parts:

Grease, Automotive and Artillery (GAA)	Appendix C, Item 19
Soda, Bicarbonate of	Appendix C, Item 33
Water, Distilled	Appendix C, Item 41

Equipment Condition:

Reference	Condition Description
Page 2-24	Batteries Disconnected

General Safety Instructions:

WARNING

- Lead-acid battery gases can explode. Do not smoke, have open flames, or make sparks around a battery, especially if caps are off. If a battery is gassing, it can explode and cause injury to personnel.
- Battery acid (electrolyte) is extremely harmful. Always wear safety goggles and rubber gloves, and do not smoke when performing maintenance on batteries. Injury will result if acid contacts skin or eyes. Wear rubber apron to prevent clothing being damaged.
- Batteries weigh 71 pounds (32 kilograms). To avoid personal injury, use a hoist or suitable lifting device when lifting batteries.

REMOVAL

1. REMOVE six wing nuts (1), six washers (2), six hook bolts (3), and mounting FRAME (4).

CAUTION

To avoid damage to batteries, place batteries on a board or wooden pallet when they are removed from vehicle.

2. REMOVE each BATTERY (5) from battery box (6).

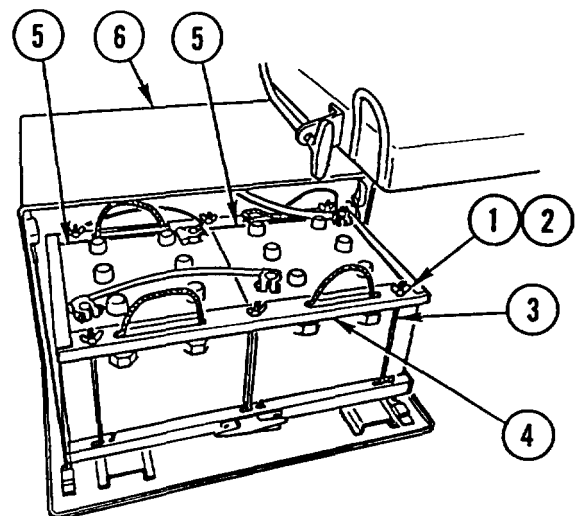

BATTERY REPLACEMENT (CONT)

SERVICE

To Check and Add Electrolyte:

1. Clean off battery caps before removing. Do not allow dirt to get into battery cells.
2. Clean vent holes in caps to allow gas to escape from cells.
3. Electrolyte level must not drop below the top of battery plates. Add distilled water to correct level indicator mark; do not overfill. Add only distilled water from a nonmetallic container. Clean rainwater may be used in an emergency.
4. Run vehicle to charge batteries, which will mix added water with the electrolyte. This is very important in cold weather to prevent battery from freezing and cracking.

To Remove and Retard Corrosion:

Corrosion is the greenish "fuzz" that builds up on the battery posts, terminals, and cables. This corrosion not only can prevent statting, but will also eat up the cables and connectors.

CAUTION

- Make sure battery caps are tight and no cracks are visible in battery case, so that no alkaline solution (acid neutralizer) reaches electrolyte.
- If the cables overheat, there may be corrosion or a break within the wiring causing electrical resistance. If possible, remove corrosion or notify unit maintenance for replacement.

1. Remove corrosion with an alkaline solution of bicarbonate of soda and water.
2. Remove terminal clamps from battery posts and clean with terminal brush.
3. Clean bolts and nuts. Check for corrosive effects.
4. Clean battery posts with wire brush and a water/soda solution. Dry battery posts.
5. Clean any corrosion from tiedowns.
6. Rinse batteries, connections, cables, and tiedowns with clear water to remove alkaline solution; dry.
7. Install and tighten terminal clamps. Apply coat of GAA to terminals, bolts, and posts to retard corrosion.
8. Keep tops of batteries clean and dry to prevent current leakage between terminals.

INSTALLATION

1. INSTALL BATTERIES (1) in battery box (2).
2. INSTALL mounting FRAME (3), six hook bolts (4), six washers (5), and six wing nuts (6).

NOTE

Follow-on Maintenance:
Connect batteries (page 2-24).

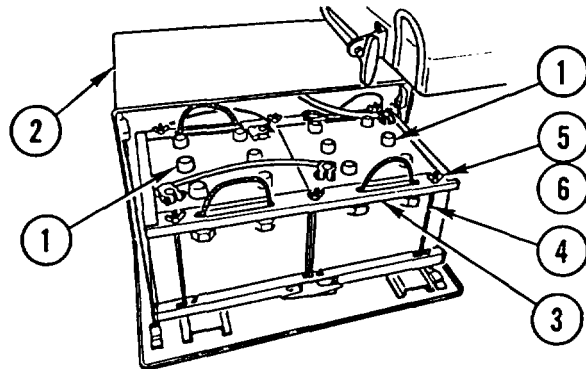

BATTERY CABLES REPLACEMENT

This task covers: a. Removal b. Installation

INITIAL SETUP

Tools and Special Equipment:

Tools Kit, SC 5180-90-CL-N26

Materials/Parts:

Washer, Spring
Tension (2)

Equipment Condition:

Reference

Page 4-219

Condition Description

Batteries Removed

REMOVAL

1. REMOVE main disconnect HANDLE (1).
2. REMOVE eight bolts (2), eight washers (3), and cover PLATE (4).
3. REMOVE two screws (5), two nuts (6), knob (7), and trailer brake control VALVE (8). SET valve ASIDE.
4. REMOVE four screws (9), four nuts (10), cap (11), and STE/ICE-R CONNECTOR (12). SET connector ASIDE.

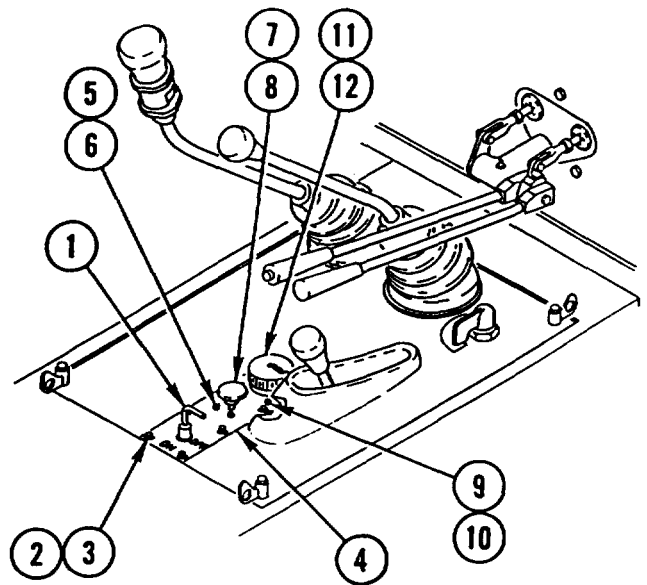

5. DISCONNECT negative LEAD (13).
6. REMOVE tie WRAP (14).

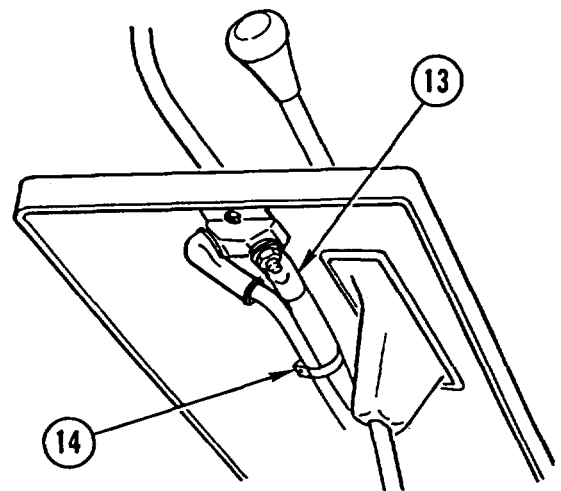

BATTERY CABLES REPLACEMENT (CONT)

7. REMOVE two tie WRAPS (15) and SLIDE NIPPLE (16) UP positive LEAD (17).

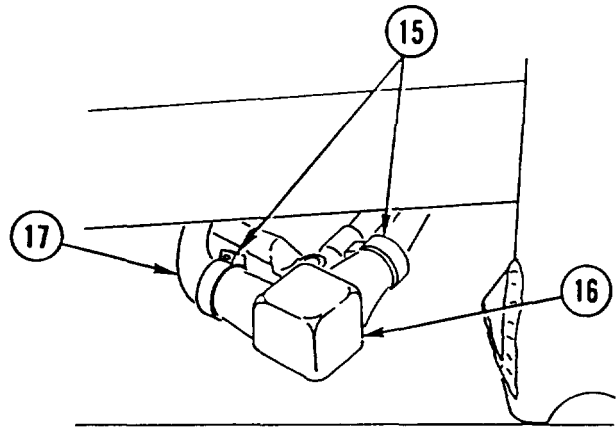

8. REMOVE nut (18), positive LEAD (17), and NIPPLE (16).

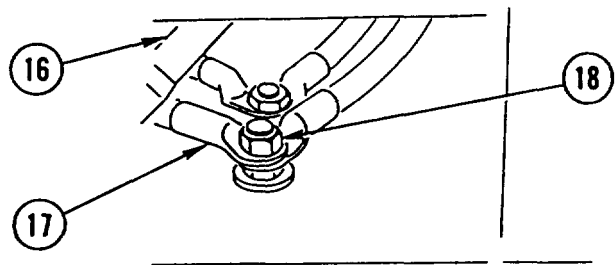

NOTE

Tag STE/ICE-R cables prior to disconnecting to aid in connecting.

9. REMOVE two NUTS (19) and DISCONNECT two STE/ICE-R CABLES (20 and 21).

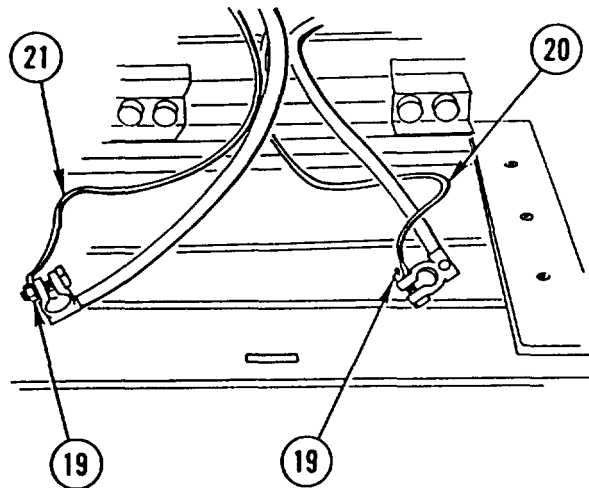

BATTERY CABLES REPLACEMENT (CONT)

10. REMOVE two nuts (22), two spring tension washers (23), two screws (24), two clamps (25), and two LEADS (13 and 17). DISCARD spring tension WASHERS.

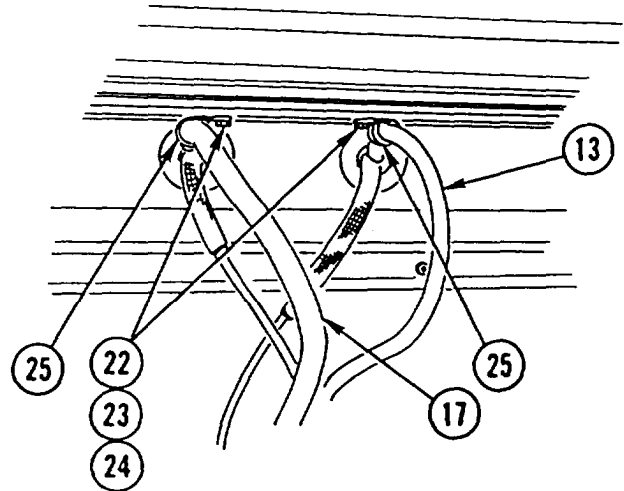

INSTALLATION

1. INSTALL two LEADS (1 and 2), two clamps (3), two screws (4), two new spring tension washers (5), and two nuts (6).

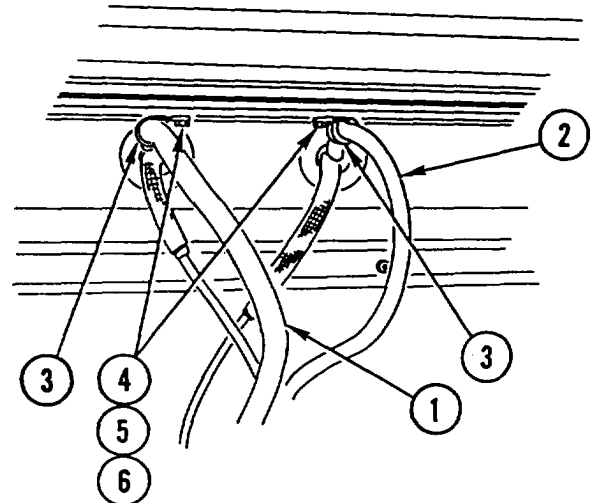

2. CONNECT two STE/ICE-R CABLES (7 and 8) and INSTALL two NUTS (9).

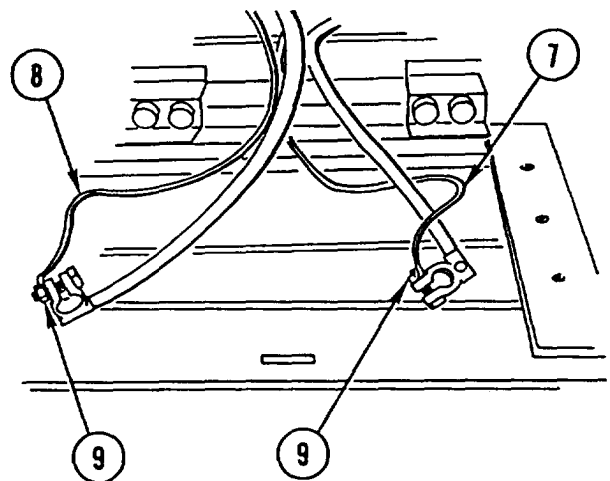

BATTERY CABLES REPLACEMENT (CONT)

3. INSTALL NIPPLE (10), positive LEAD (1), and nut (11).

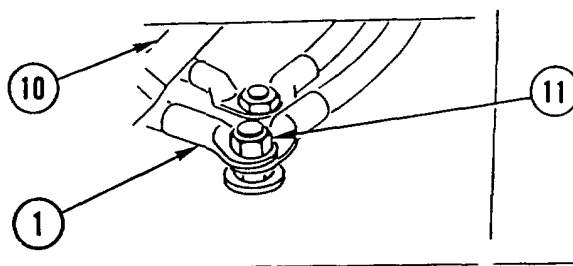

4. SLIDE NIPPLE (10) DOWN positive LEAD (1) so that it covers nut (11) and slips over lead (12), and INSTALL two tie WRAPS (13).

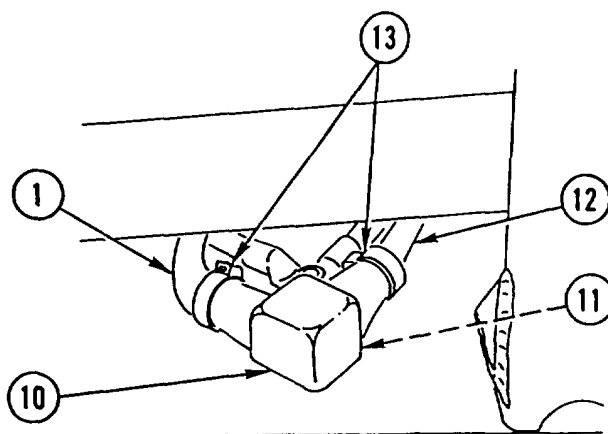

5. CONNECT negative LEAD (2).
6. INSTALL tie WRAP (14).

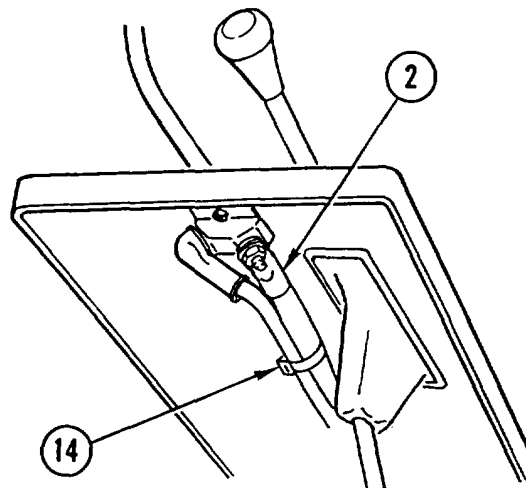

BATTERY CABLES REPLACEMENT (CONT)

7. INSTALL STE/ICE-R CONNECTOR (15), cap (16), four screws (17), and four nuts (18).
8. INSTALL trailer brake control VALVE (19), knob (20), two screws (21), and two nuts (22).
9. INSTALL cover PLATE (23), eight washers (24), and eight bolts (25).
10. INSTALL main disconnect HANDLE (26).

NOTE

Follow-on Maintenance:
Install batteries (page 4-219).

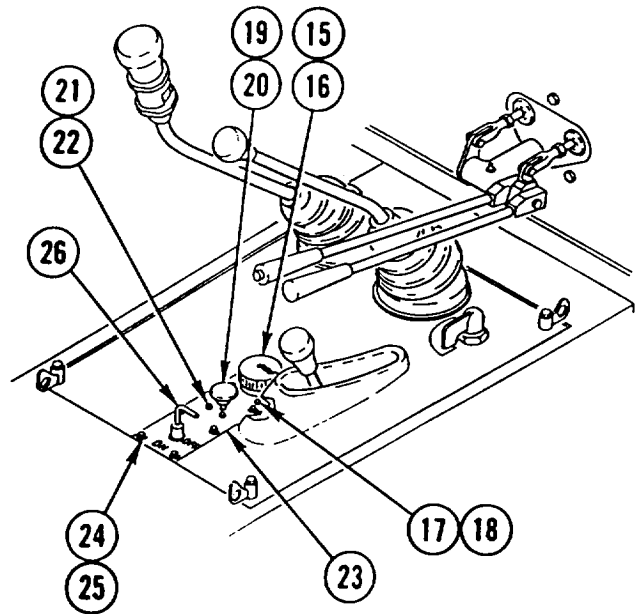

BATTERY BOX REPLACEMENT

This task covers: a. Removal b. Installation

INITIAL SETUP

Tools and Special Equipment:

Tool Kit, SC 5180-90-CL-N26

Materials/Parts:

Washer, Lock

Nut, Lock (4)

Nut, Lock (8)

Equipment Condition:

Reference

Page 4-219

Page 4-172

Page 4-221

Page 4-213

Condition Description

Batteries Removed

Slave Receptacle
Removed

Battery Cables Removed

STE/ICE-R Shunt
Removed

REMOVAL

1. REMOVE PLATE (1).
2. REMOVE nut (2), lock washer (3), screw (4), two clamps (5), and two CUSHIONS (6) from battery box (7). DISCARD lock WASHER.
3. REMOVE four lock nuts (8), four capscrews (9), and battery BOX (7). DISCARD lock NUTS.
4. REMOVE eight lock nuts (10), eight capscrews (11), and two BRACKETS (12). DISCARD lock NUTS.
5. REMOVE two nuts (13), shim(s) (14), four capscrews (15), two TRAYS (16), and two SUPPORTS (17).

INSTALLATION

1. INSTALL two SUPPORTS (17), two TRAYS (16), four capscrews (15), shim(s) (14), and two nuts (13).
2. INSTALL two BRACKETS (12), eight capscrews (11), and eight new lock nuts (10).
3. INSTALL battery BOX (7), four capscrews (9), and four new lock nuts (8).
4. INSTALL two CUSHIONS (6), two clamps (5), screw (4), new lock washer (3), and nut (2) on battery box (7).
5. INSTALL PLATE (1).

NOTE

Follow-on Maintenance:

- Install battery cables (page 4-221).
- Install slave receptacle (page 4-172).
- Install batteries (page 4-219).
- Install STE/ICE-R shunt (page 4-213).

BATTERY BOX REPLACEMENT (CONT)

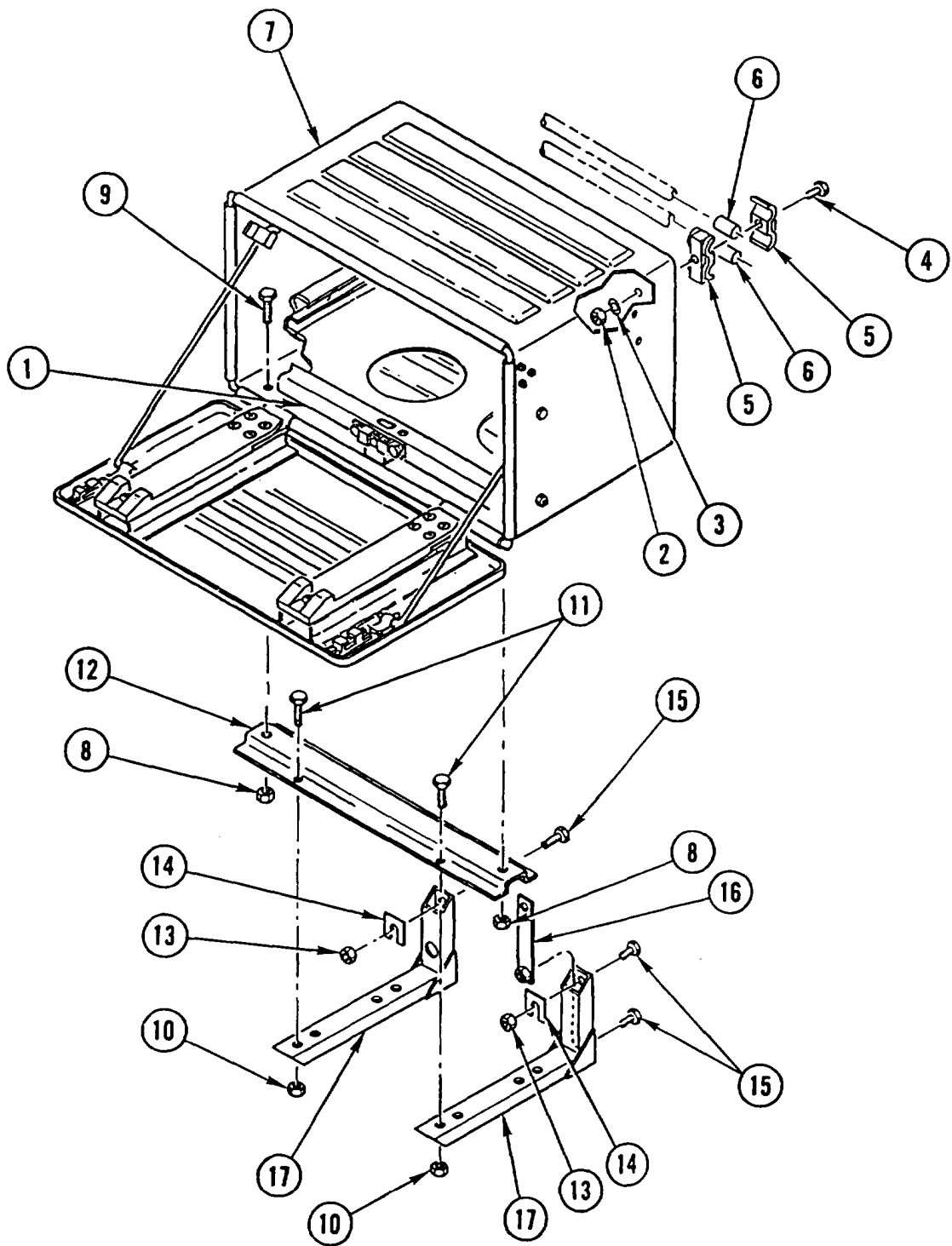

BATTERY BOX REPAIR

This task covers: a. Disassembly b. Assembly

INITIAL SETUP

Tools and Special Equipment:

Tool Kit, SC 5180-90-CL-N26

Equipment Condition:

Reference	Condition Description
------------------	------------------------------

Materials/Parts:

<p>Page 4-226</p> <p>Nut, Lock (2)</p> <p>Washer, Spring Tension (34)</p>	<p>Battery Box Removed</p>
---	----------------------------

DISASSEMBLY

1. REMOVE two lock nuts (1), two screws (2), and BUTTON (3) from plate (4). DISCARD lock NUTS.
2. REMOVE six nuts (5), six spring tension washers (6), six screws (7), and two BRACKETS (8) from battery box (9). DISCARD spring tension WASHERS.
3. REMOVE two nuts (10), two spring tension washers (11), and two SCREWS (12) from battery box (9). DISCARD spring tension WASHERS.
4. REMOVE 10 screws (13), 10 spring tension washers (14), 2 inserts (15), and COVER (16) from battery box (9). DISCARD spring tension WASHERS.
5. REMOVE four nuts (17), four spring tension washers (18), four bolts (19), two LOCKS (20), and four washers (21) from cover (16). DISCARD spring tension WASHERS.
6. REMOVE six nuts (22), six spring tension washers (23), six screws (24), and two INSERTS (25) from battery box (9). DISCARD spring tension WASHERS.
7. REMOVE six nuts (26), six spring tension washers (27), six screws (28), and two DETENTS (29) from battery box (9). DISCARD spring tension WASHERS.
8. REMOVE four BUMPERS (30) from battery box (9).

ASSEMBLY

1. INSTALL four BUMPERS (30) in battery box (9).
2. INSTALL two DETENTS (29), six screws (28), six new spring tension washers (27), and six nuts (26) in battery box (9).
3. INSTALL two INSERTS (25), six screws (24), six new spring tension washers (23), and six nuts (22) in battery box (9).
4. INSTALL four washers (21), two LOCKS (20), four bolts (19), four new spring tension washers (18), and four nuts (17) in cover (16).
5. INSTALL COVER (16), 2 inserts (15), 10 new spring tension washers (14), and 10 screws (13) on battery box (9).

BATTERY BOX REPAIR (CONT)

6. INSTALL two SCREWS (12), two new spring tension washers (11), and two nuts (10) in battery box (9).
7. INSTALL two BRACKETS (8), six screws (7), six new spring tension washers (6), and six nuts (5) in battery box (9).
8. INSTALL BUTTON (3), two screws (2), and two new lock nuts (1) in plate (4).

NOTE

Follow-on Maintenance:

Install battery box (page 4-226).

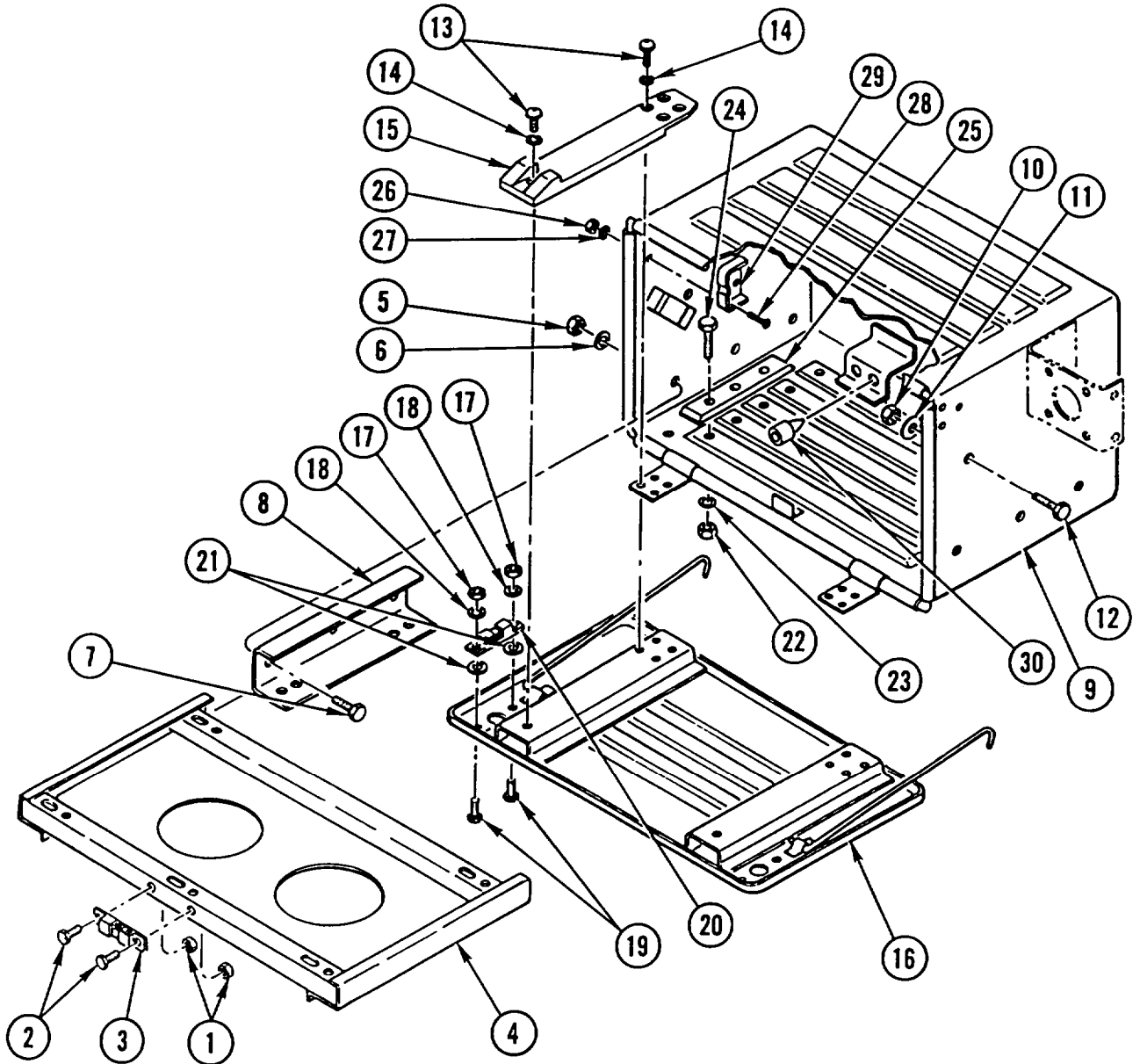

TRAILER CONNECTION REPLACEMENT

This task covers: a. Removal b. Installation

INITIAL SETUP

Tools and Special Equipment:

Tool Kit, SC 5180-90-CL-N26

REMOVAL

1. REMOVE four screws (1), four nuts (2), and COVER (3).
2. PULL trailer connection (4) CABLE TO REAR of vehicle and SLIDE CABLE OUT through slot in bracket (5).

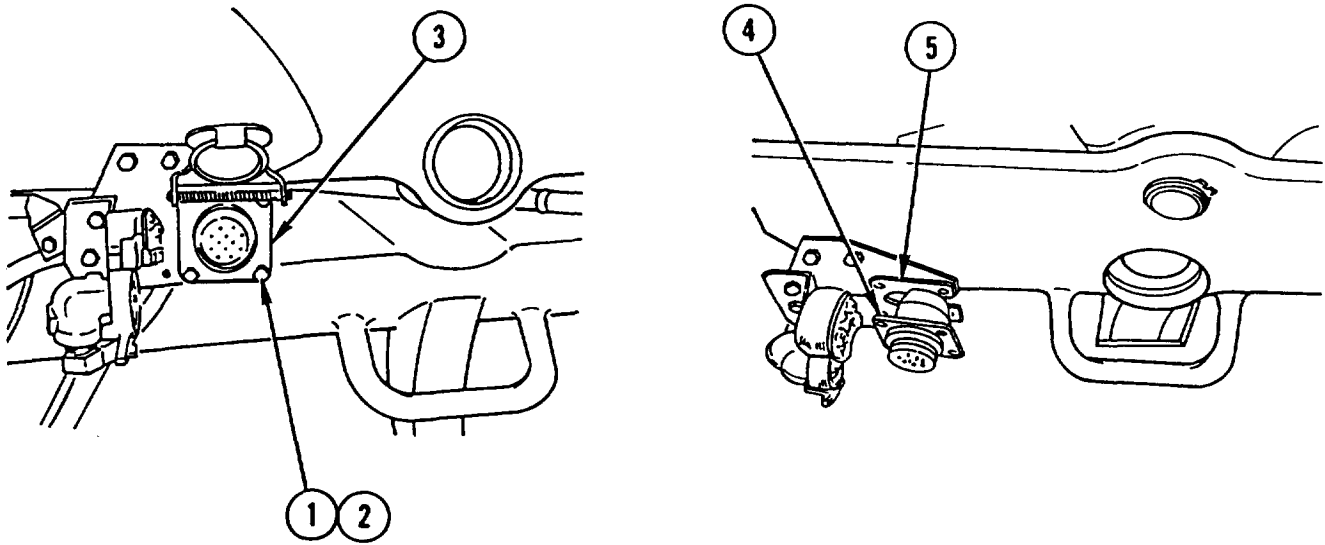

INSTALLATION

1. SLIDE trailer connection (4) CABLE THROUGH slot in bracket (5) and PUSH CABLE TOWARD FRONT of vehicle.
2. INSTALL COVER (3), four screws (1), and four nuts (2).

FRONT DISC BRAKE PAD INDICATOR WIRING HARNESS REPLACEMENT

This task covers: a. Removal b. Inspection c. Installation

INITIAL SETUP

Tools and Special Equipment:

Tool Kit, SC 5180-90-CL-N26

Equipment Condition:

Reference	Condition Description
Page 4-335	Front Wheel Assemblies Removed

General Safety Instructions:

WARNING

Remove or disconnect batteries and turn vehicle MASTER disconnect switch OFF prior to performing maintenance in immediate battery area or working on electrical system. Such disconnections prevent electrical shock to personnel or equipment.

REMOVAL

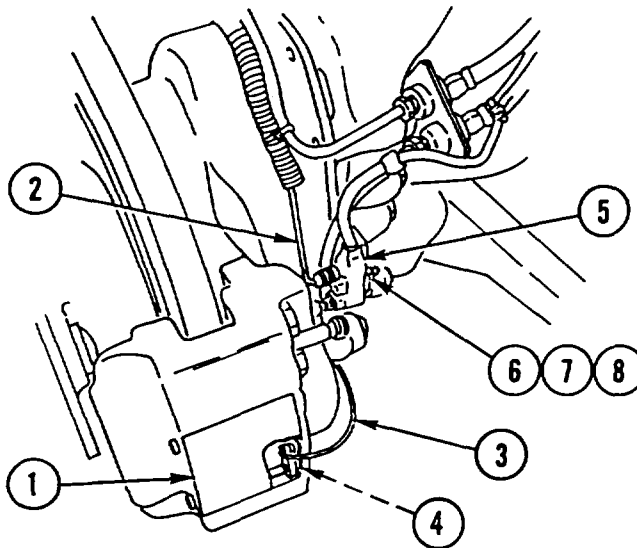

1. REMOVE two dust COVERS (1).

NOTE

Tag leads prior to disconnecting to aid in connecting.

2. DISCONNECT two LEADS (2 and 3) from disc pad (4) and block (5).
3. REMOVE screw (6), washer (7), nut (8), and BLOCK (5).
4. REPEAT STEPS 1 thru 3 for other side of axle.

**FRONT DISC BRAKE PAD INDICATOR WIRING HARNESS
REPLACEMENT (CONT)**

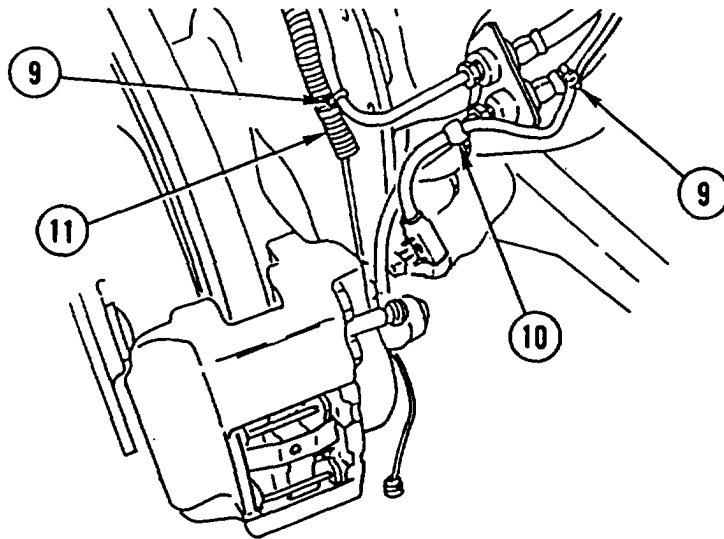

5. REMOVE seven straps (9), clamp (10), and CONDUIT (11) from left side.

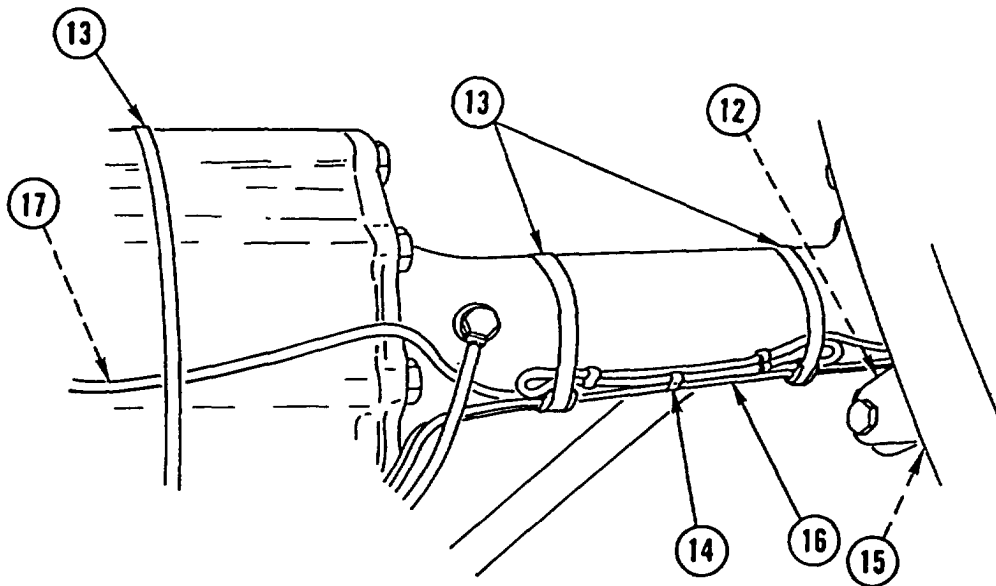

6. REMOVE seven straps (12), three clamps (13), nine clamps (14), and CONDUIT (15) from right side.
7. DISCONNECT and REMOVE WIRING HARNESS (16) from vehicle.
8. REMOVE two STRAPS (17) from wiring harness (16).

INSPECTION

1. Inspect connectors for corrosion.
2. Inspect wiring harness for cracks, chafing, or damaged blocks.

**FRONT DISC BRAKE PAD INDICATOR WIRING HARNESS
REPLACEMENT (CONT)**

INSTALLATION

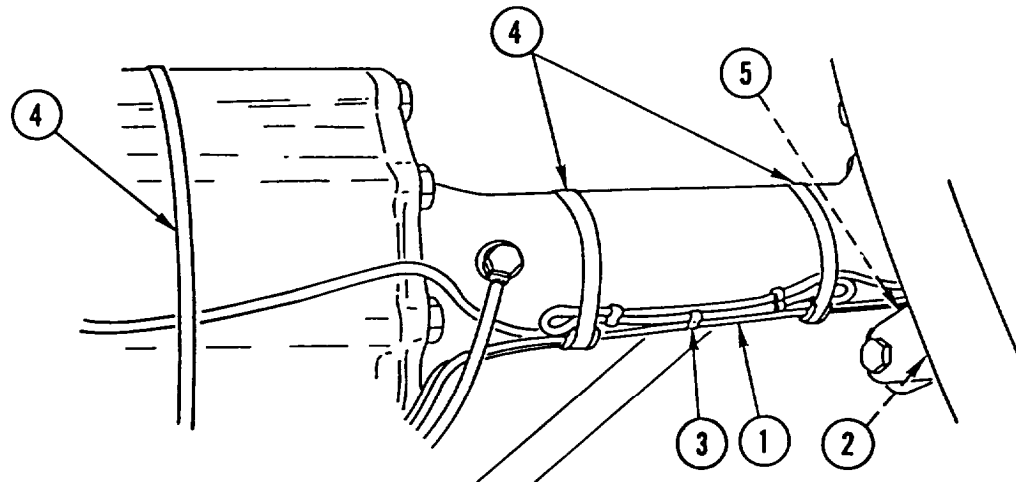

1. INSTALL WIRING HARNESS (1), conduit (2), nine clamps (3), three clamps (4), and seven straps (5) on right side.

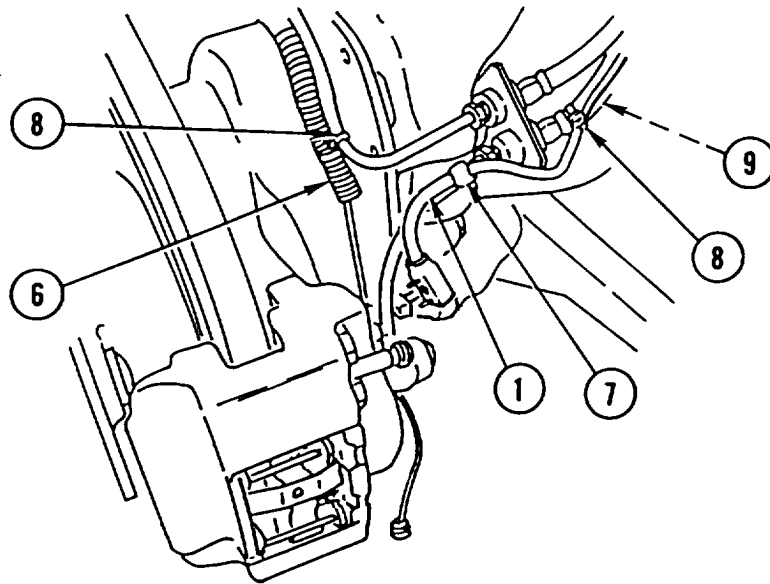

2. INSTALL WIRING HARNESS (1), conduit (6), clamp (7), and seven straps (8) on left side.
3. CONNECT WIRING HARNESS (1) and secure extra wire with two straps (9).

**FRONT DISC BRAKE PAD INDICATOR WIRING HARNESS
REPLACEMENT (CONT)**

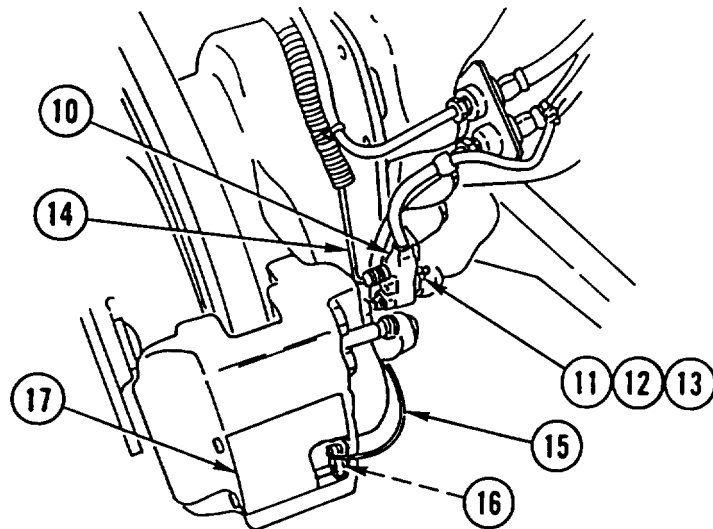

4. INSTALL BLOCK (10), nut (11), washer (12), and screw (13).
5. CONNECT two LEADS (14 and 15) to disc pad (16) and block (10).
6. INSTALL two dust COVERS (17).
7. REPEAT STEPS 4 thru 6 for other side.

NOTE

Follow-on Maintenance:
Install front wheel assemblies (page 4-335).

SUPPRESSOR FILTERS REPLACEMENT

This task covers: a. Removal b. Installation

INITIAL SETUP**Tools and Special Equipment:**

Tool Kit, SC 5180-90-CL-N26

Materials/Parts:

Washer, Lock

Equipment Condition:**Reference**

Page 4-418

Page 4-360

Condition Description

Cab Tilted

Power Steering Tank
(Reservoir) Removed

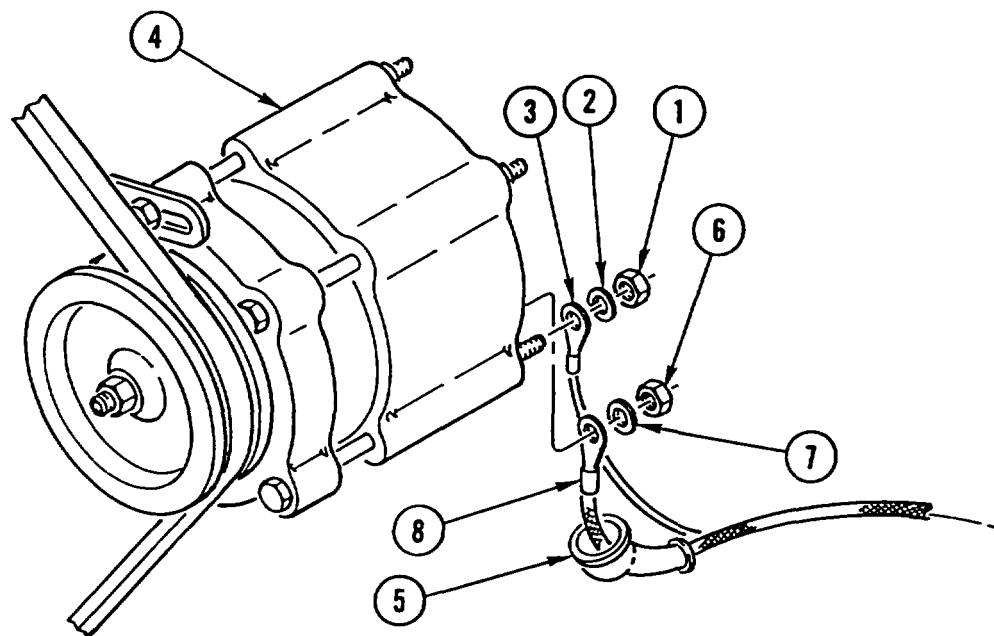
REMOVAL**NOTE**

Tag all wires prior to removal to aid in installation.

1. REMOVE nut (1), lock washer (2), and WIRE (3) from alternator (4). DISCARD lock WASHER.

CAUTION

Use care when performing step 2 to prevent damage to rubber cover.

2. ROLL rubber COVER (5) BACK from nut (6).
3. REMOVE nut (6), washer (7), and WIRE (8) from alternator (4).

SUPPRESSOR FILTERS REPLACEMENT (CONT)

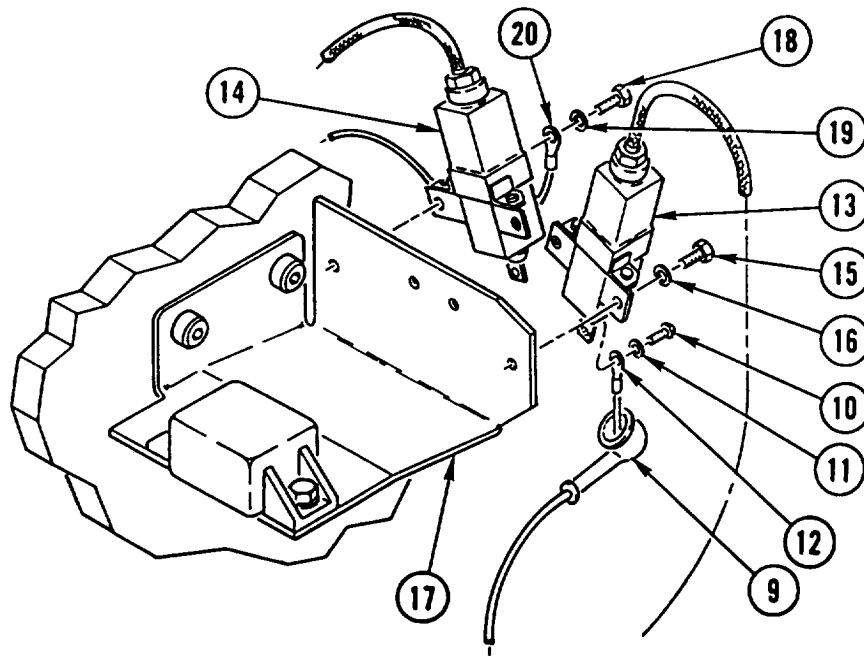

CAUTION

Use care when performing step 4 to prevent damage to rubber cover.

4. ROLL rubber COVER (9) BACK from screw (10).
5. REMOVE screw (10), washer (11), and WIRE (12) from suppressor filter (13).
6. REPEAT STEPS 1 thru 5 for suppressor filter (14).

NOTE

Orientation for steps 7 and 8 is looking from rear of alternator.

7. ON LEFT SIDE, REMOVE two screws (15), two washers (16), and suppressor FILTER (13) from bracket (17).
8. ON RIGHT SIDE, REMOVE two screws (18), two washers (19), WIRE (20), and suppressor FILTER (14) from bracket (17).

INSTALLATION

NOTE

Orientation for steps 1 and 2 is looking from rear of alternator.

1. ON RIGHT SIDE, INSTALL suppressor FILTER (1), WIRE (2), two washers (3), and two screws (4) on bracket (5).
2. ON LEFT SIDE, INSTALL suppressor FILTER (6), two washers (7), and two screws (8) on bracket (5).
3. INSTALL WIRE (9), washer (10), and screw (11) on suppressor filter (6).

SUPPRESSOR FILTERS REPLACEMENT (CONT)

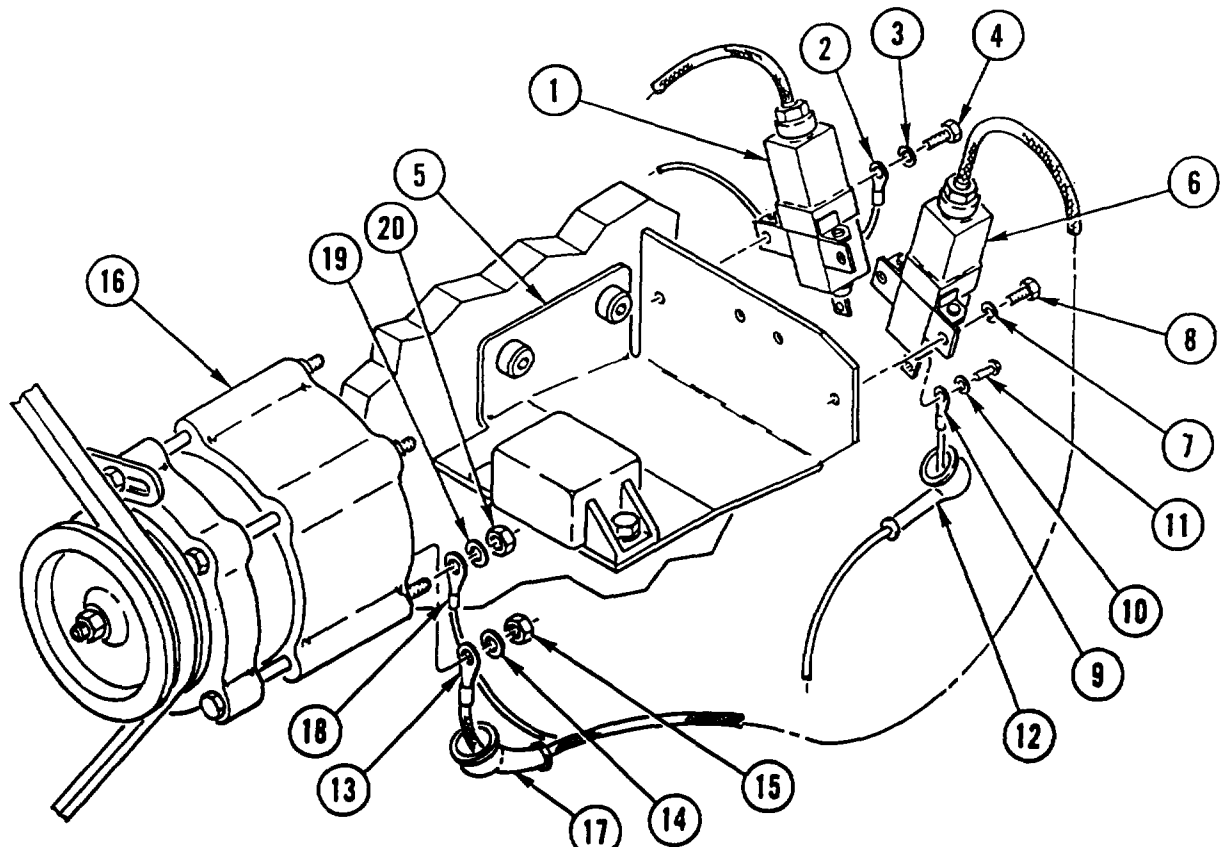
**CAUTION**

Use care when performing step 4 to prevent damage to rubber cover.

4. ROLL rubber COVER (12) OVER screw (11).
5. INSTALL WIRE (13), washer (14), and nut (15) on alternator (16).

CAUTION

Use care when performing step 6 to prevent damage to rubber cover.

6. ROLL rubber COVER (17) OVER nut (15).
7. INSTALL WIRE (18), new lock washer (19), and nut (20) on alternator (16).
8. REPEAT STEPS 3 thru 7 for suppressor filter (1).

NOTE

Follow-on Maintenance:

Install power steering tank (reservoir) (page 4-360).
Lower cab (page 4-418).

ENGINE TEMPERATURE SWITCH REPLACEMENT

This task covers: a. Removal b. Installation

INITIAL SETUP

Tools and Special Equipment:

Tool Kit, SC 5180-90-CL-N26

Equipment Condition:

Reference	Condition Description
Page 2-24	Batteries Disconnected
Page 4-389	Inside Engine Hood Removed

REMOVAL

1. DISCONNECT two CONNECTORS (1).
2. REMOVE capscrew (2) and engine temperature SWITCH (3) from oil cooler (4).

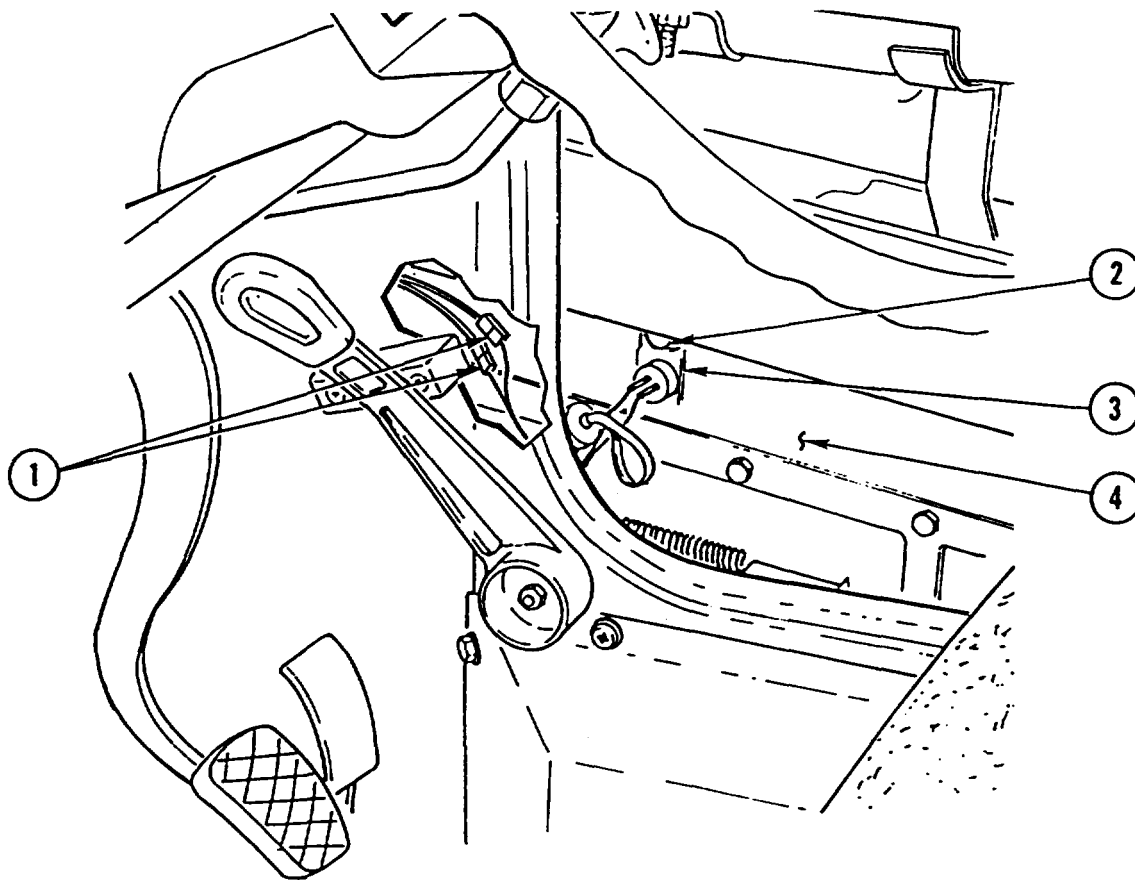

ENGINE TEMPERATURE SWITCH REPLACEMENT (CONT)

INSTALLATION

1. INSTALL engine temperature SWITCH (3) and capscrew (2) in oil cooler (4).
2. CONNECT two CONNECTORS (1).

NOTE

Follow-on Maintenance:

Connect batteries (page 2-24).
Install inside engine hood (page 4-389).

Section VII. TRANSMISSION MAINTENANCE

OVERVIEW

This section illustrates and describes procedures for maintenance of the transmission and related parts. A list of tasks contained in this section is shown below.

	Page
All Wheel Drive Selector Valve Replacement	4-240
All Wheel Drive Pressure Regulator Replacement	4-242
All Wheel Drive Control Cylinder Replacement and Adjustment	4-243

ALL WHEEL DRIVE SELECTOR VALVE REPLACEMENT

This task covers: a. Removal b. Installation

INITIAL SETUP

Tools and Special Equipment:

Tool Kit, SC 5180-90 -CL-N26

Materials/Parts:

Seal (6)

Equipment Condition:

Reference	Condition Description
Page 4-418	Cab Tilted
Page 2-23	Air Pressure Relieved

General Safety Instructions:

WARNING

Do not disconnect any air system lines or fittings unless vehicle engine is shut off and air system pressure is relieved. To do so could result in injury to personnel.

REMOVAL

NOTE

Tag lines prior to removal to aid in installation.

1. REMOVE three screws (1), six seals (2), and three air LINES (3) from all wheel drive selector valve (4). DISCARD SEALS.
2. REMOVE LEVER (5).
3. REMOVE nut (6), two washers (7 and 8), and VALVE (4).

ALL WHEEL DRIVE SELECTOR VALVE REPLACEMENT (CONT)

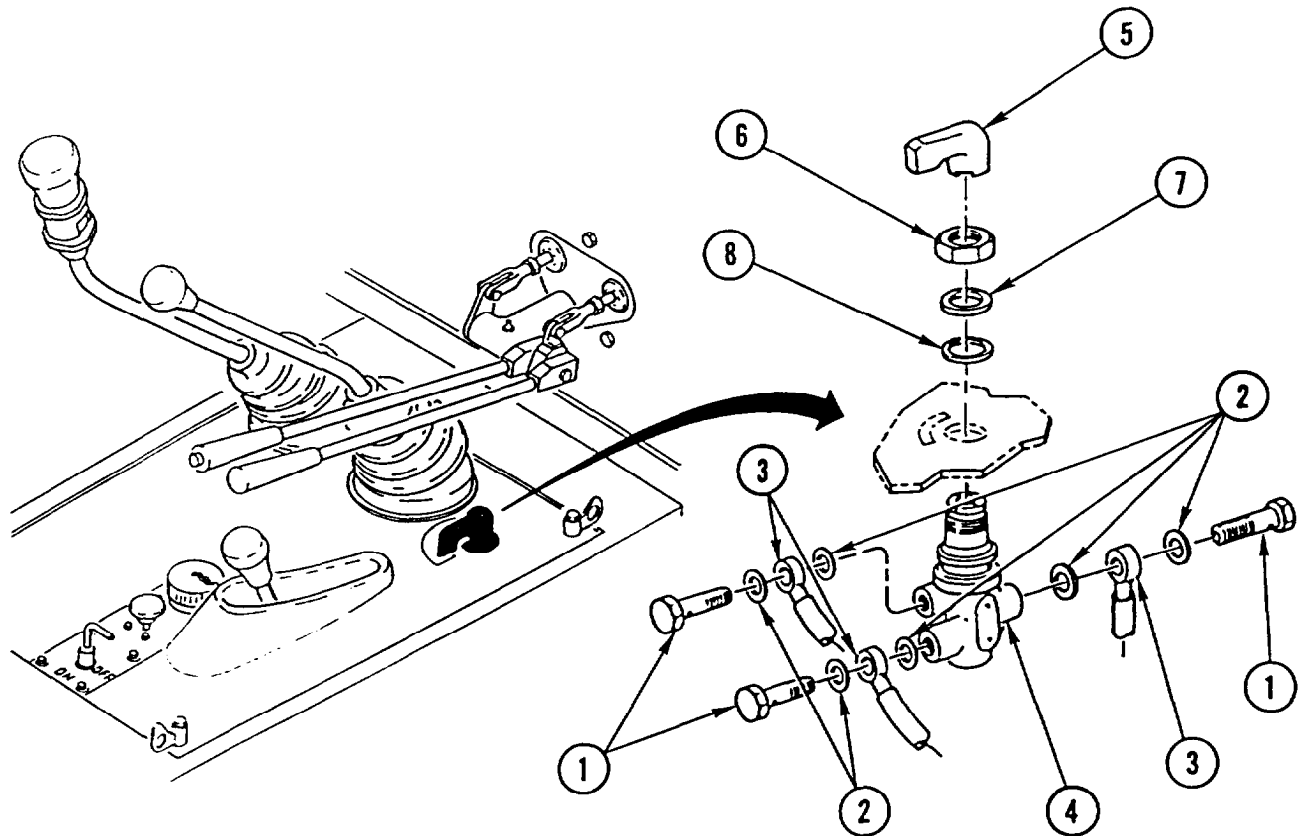
**INSTALLATION**

1. INSTALL all wheel drive selector VALVE (4), two washers (7 and 8), and nut (6).
2. INSTALL LEVER (5).
3. INSTALL three screws (1), six new seals (2), and three air LINES (3) on valve (4).

NOTE

Follow-on Maintenance:

Lower cab (page 4-418).

ALL WHEEL DRIVE PRESSURE REGULATOR REPLACEMENT

This task covers: a. Removal b. Installation

INITIAL SETUP

Tools and Special Equipment:

Tool Kit, SC 5180-90-CL-N26

Materials/Parts:

Seal (2)

Retainer

Packing

Equipment Condition:

Reference	Condition Description
Page 4-418	Cab Tilted
Page 2-23	Air Pressure Relieved

General Safety Instructions:

WARNING

Do not disconnect any air system lines unless all wheel drive selector switch is in two wheel drive and air system pressure is relieved. To do so could result in injury to personnel.

REMOVAL

1. REMOVE fluid passage BOLT (1) and two seals (2). DISCARD SEALS.
2. LOOSEN UNION (3) and Disconnect HOSE (4).
3. REMOVE two nuts (5), two washers (6), two capscrews (7), and pressure regulator VALVE (8).
4. REMOVE FITTING (9), retainer (10), and packing (11). DISCARD RETAINER and PACKING.

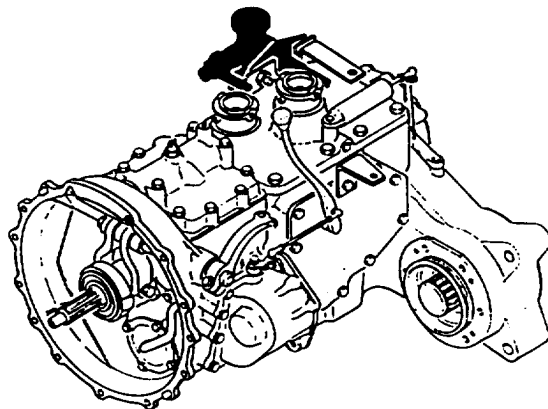

INSTALLATION

1. INSTALL new packing (11), new retainer (10), and FITTING (9).
2. INSTALL pressure regulator VALVE (8), two capscrews (7), two washers (6), and two nuts (5).
3. CONNECT HOSE (4) and TIGHTEN UNION (3).
4. INSTALL two new seals (2) and fluid passage BOLT (1).

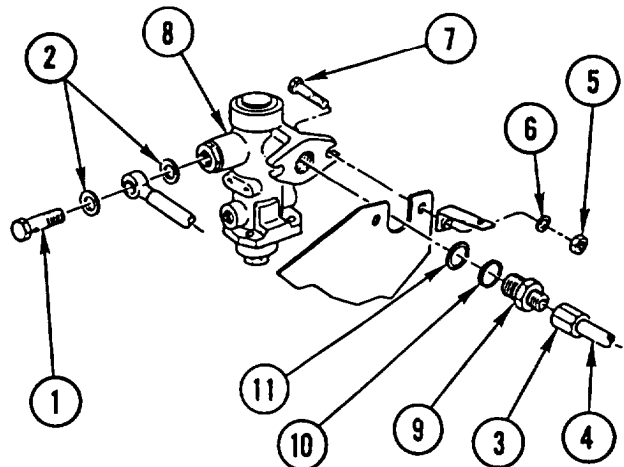

NOTE

Follow-on Maintenance:
Lower cab (page 4-418).

ALL WHEEL DRIVE CONTROL CYLINDER REPLACEMENT AND ADJUSTMENT

This task covers: a. Removal b Installation c. Adjustment

INITIAL SETUP

Tools and Special Equipment:

Tool Kit, SC 5180-90 -CL-N26

Materials/Parts:

Packing (3)

Equipment Condition:

Reference	Condition Description
Page 4-418	Cab Tilted
Page 2-23	Air Pressure Relieved

General Safety Instructions:

WARNING

Do not disconnect any air system lines unless all wheel drive selector switch is in two wheel drive and air system pressure is relieved. To do so could result in injury to personnel.

REMOVAL

NOTE

Tag lines prior to disconnecting to aid in connecting.

1. DISCONNECT two air HOSES (1) by REMOVING fluid passage BOLT (2) and three packings (3). DISCARD PACKINGS.
2. REMOVE retaining ring (4), washer (5), and CYLINDER (6).
3. REMOVE CLIP (7) and DISCONNECT ball RETAINER (8) from pivot ball (9).

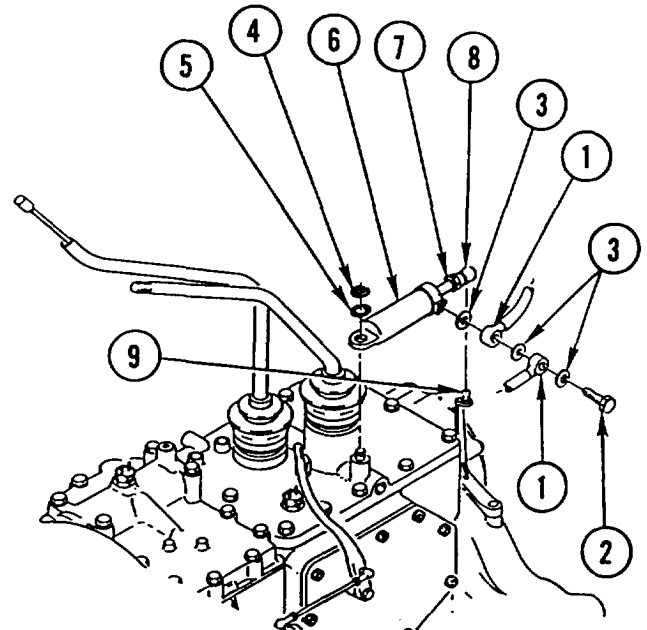

INSTALLATION

1. INSTALL CYLINDER (6), washer (5), and retaining ring (4).
2. CONNECT two air HOSES (1) by INSTALLING three new packings (3) and fluid passage BOLT (2).

**ALL WHEEL DRIVE CONTROL CYLINDER REPLACEMENT AND
ADJUSTMENT (CONT)**

ADJUSTMENT

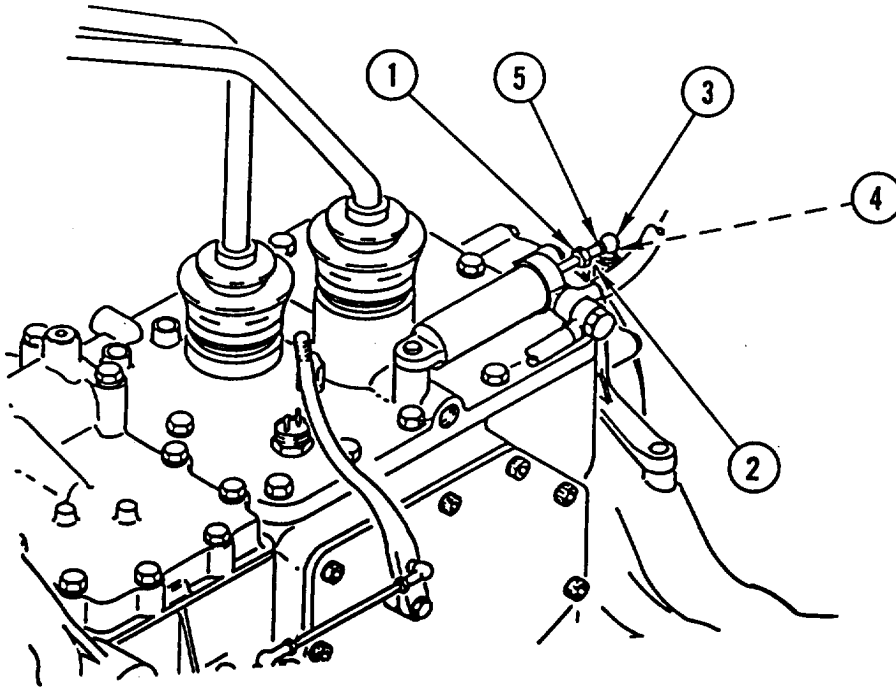

1. Loosen nut (1).
2. Move all wheel drive selector lever (2) all the way to rear of transmission.
3. Rotate ball retainer (3) either clockwise or counterclockwise so bail retainer will engage pivot ball (4).
4. Install clip (5) and tighten nut (1).

NOTE

Follow-on Maintenance:

Lower cab (page 4-418).

Section VIII. FRONT AND REAR AXLES MAINTENANCE

OVERVIEW

This section illustrates and describes procedures for maintenance of the front and rear axles and related parts. A list of tasks contained in this section is shown below:

	Page
Axle Vent Hoses Replacement	4-245
Front Axle Final Drive Outer Seal Replacement	4-247
Rear Axle Final Drive Outer Seal Replacement	4-248

AXLE VENT HOSES REPLACEMENT

This task covers: a. Removal b. Installation

INITIAL SETUP

Tools and Special Equipment:

Shop Equipment, SC 4910-95-CL-A74
 Tool Kit, SC 5180-90-CL-N26
 Clamp, P/N 451 42 110

General Safety Instructions:

WARNING

Do not disconnect any axle vent fittings unless all wheel drive selector valve is closed and air system pressure is relieved. To do so could result in injury to personnel.

Materials/Parts:

Seal (AR)
 Seal (AR)

Equipment Condition:

Reference	Condition
Page 2-23	Air Pressure Relieved

REMOVAL

NOTE

- Tag hoses prior to removal to aid in installation.
- Discard seals(s).

REMOVE axle vent HOSES and FITTINGS using illustration and legend as a guide.

AXLE VENT HOSES REPLACEMENT (CONT)

INSTALLATION

NOTE

- Install new seal(s).
- Use clamp to connect fittings to hoses.

INSTALL axle vent HOSES and FITTINGS using illustration and legend as a guide.

LEGEND

- 1 Bolt (3)
- 2 Seal (6)
- 3 Connector (3)
- 4 Hose (6)
- 5 Sleeve (3)
- 6 Sleeve (3)
- 7 Union (3)
- 8 Clamp
- 9 Strap
- 10 Connector

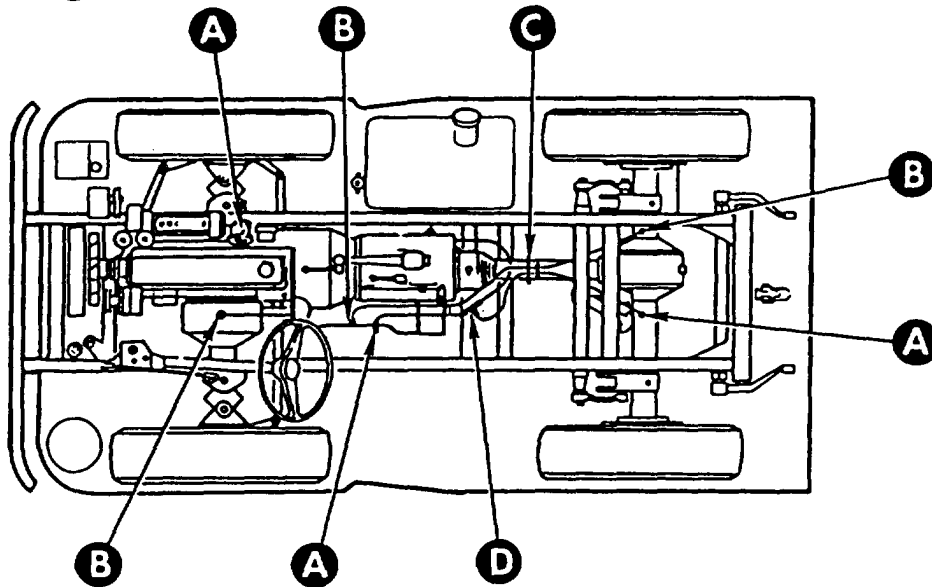
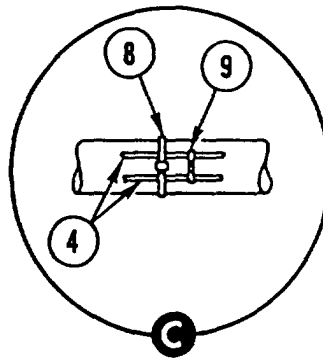
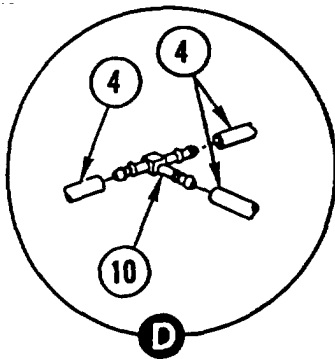
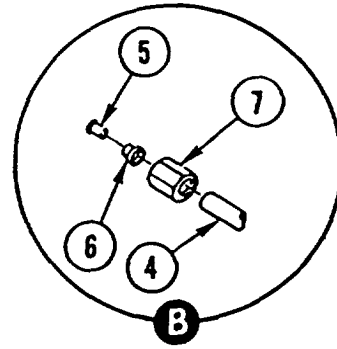
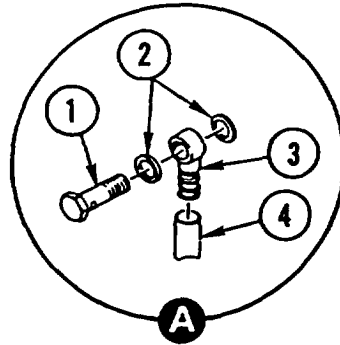

FRONT AXLE FINAL DRIVE OUTER SEAL REPLACEMENT

This task covers: a. Removal b. Installation

INITIAL SETUP

Tools and Special Equipment:

Shop Equipment, SC 4910-95-CL-A74
 Tool Kit, SC 5180-90-CL-N26
 Installing Tool, P/N 424 589 01 43 00
 Mandrel, P/N 406 589 04 15 00

Equipment Condition:

Reference	Condition Description
Page 4-265	Brake Disc and Hub Removed

Materials/Parts:

Seal
 Spacer

REMOVAL

REMOVE and DISCARD SEAL (1) and SPACER (2).

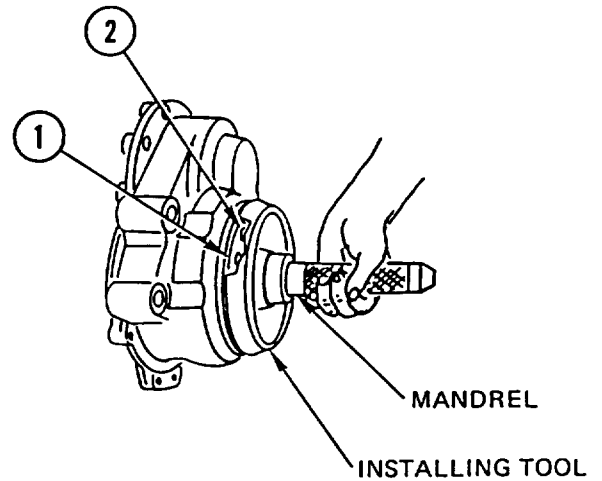
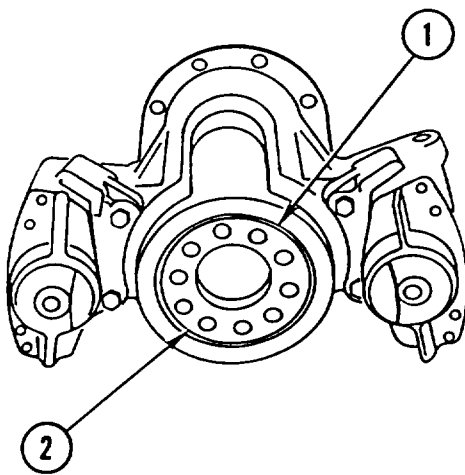

INSTALLATION

USING MANDREL and INSTALLING TOOL, INSTALL new SEAL (1) and new SPACER (2) together.

NOTE

Follow-on Maintenance:
 Install brake disc and hub (page 4-265).

REAR AXLE FINAL DRIVE OUTER SEAL REPLACEMENT

This task covers: a. Removal b. Installation

INITIAL SETUP

Tools and Special Equipment:

Shop Equipment, SC 4910-95-CL-A74
Tool Kit, SC 5180-90-CL-N26
Installing Tool, P/N 42458901 4300
Mandrel, P/N 406 589 04 15 00

Equipment Condition:

Reference

Page 4-265

Condition Description:

Brake Disc and Hub
Removed

Materials/Parts:

Seal
Spacer

REMOVAL

REMOVE and DISCARD SEAL (1) and SPACER (2).

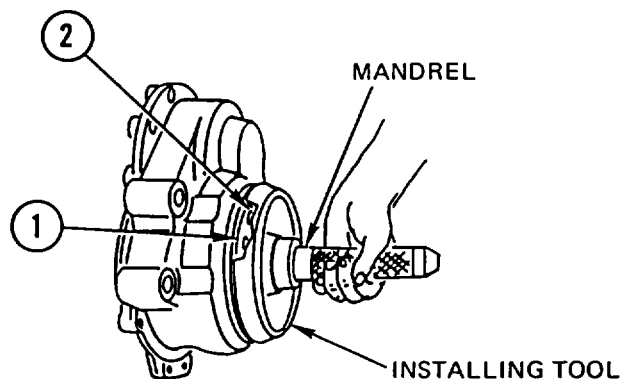
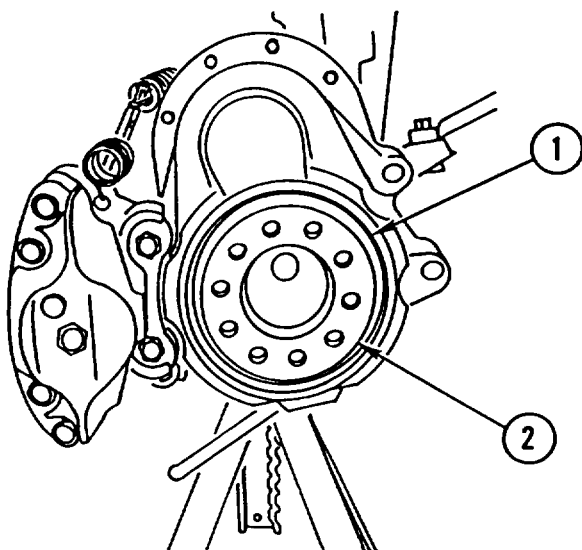

INSTALLATION

USING MANDREL and INSTALLING TOOL, INSTALL new SEAL (1) and new SPACER (2) together.

NOTE

Follow-on Maintenance:
Install brake disc and hub (page 4-265).

Section IX. BRAKE MAINTENANCE

OVERVIEW

This section illustrates and describes procedures for maintenance of the brakes and related parts. A list of tasks contained in this section is shown below.

	Page
Parking Brake Controls Replacement	4-251
Parking Brake Adjustment	4-254
Brake Fluid Reservoir Replacement	4-257
Front Trailer Coupling Replacement	4-259
Protection/Relay Valve Replacement	4-261
Brake System Bleeding	4-262
Brake Disc and Hub Replacement	4-265
Rear Disc Brake Pad Replacement	4-268
Front Disc Brake Pad Replacement	4-271
Brake Caliper Replacement	4-274
Brake Master Cylinder Replacement	4-276
Rear Brake Calipers Hydraulic Lines and Fittings Replacement	4-278
Brake Master Cylinder Hydraulic Lines and Fittings Replacement	4-280
Brake Pressure Regulator (ALB Valve) Lines and Fittings Replacement	4-282
Front Brake Calipers Hydraulic Lines and Fittings Replacement	4-284
Brake Pedal Replacement	4-286
Brake Pedal Adjustment	4-287
Air Pressure Tanks Replacement	4-288
Air Brake Booster Replacement..	4-295
Antifreeze Reservoir Replacement	4-298
Antifreeze Device Replacement	4-300
Large Air Pressure Tank Overflow Valve and Fittings Replacement	4-302
Small Air Pressure Tank Overflow Valve and Fittings Replacement	4-303
Accessory Air Supply Overflow Valve and Fittings Replacement	4-304

	Page
Fluid Regulating Valve Replacement	4-306
Trailer Service Air Supply Lines and Fittings Replacement	4-307
Trailer Emergency Air Supply Lines and Fittings Replacement	4-310
Trailer Air Supply Valve Lines and Fittings Replacement	4-313
Air Pressure and Accessory Air Supply Lines and Fittings Replacement	4-315
Brake Booster and Air Pressure Lines and Fittings Replacement	4-318
Protection/Relay Valve Lines and Fittings Replacement	4-320
Tandem Valve Replacement	4-322
Air System Supply Lines and Fittings Replacement	4-324
Trailer Hand Brake Valve Replacement	4-326
Trailer Air Supply Lines and Fittings Replacement	4-327
Trailer Hand Brake Valve Lines and Fittings Replacement	4-329
Trailer Air Supply Valve Replacement	4-331
Tractor Protection Valve Replacement	4-332
Trailer Hand Brake Air Supply Lines and Fittings Replacement	4-333

PARKING BRAKE CONTROLS REPLACEMENT

This task covers: a. Removal b. Installation

INITIAL SETUP

Tools and Special Equipment:

Shop Equipment, SC 4910-95-CL-A74
 Tool Kit, SC 5180-90-CL-N26

Personnel Required: (2)

Equipment Condition:

Reference	Condition Description
Page 4-418	Cab Tilted
Page 2-22	Vehicle Blocked

REMOVAL

1. AT REAR of VEHICLE, UNSNAP RETAINER (1).
2. REMOVE pin (2) and CLEVIS (3) from lever (4).
3. REMOVE CABLE (5) from center mounting point (6).
4. PULL hand BRAKE (7) back sufficiently to EXPOSE cable END (8).
5. LOOSEN jam NUT (9) and UNSCREW hand brake (7) HANDLE from cable end (8).

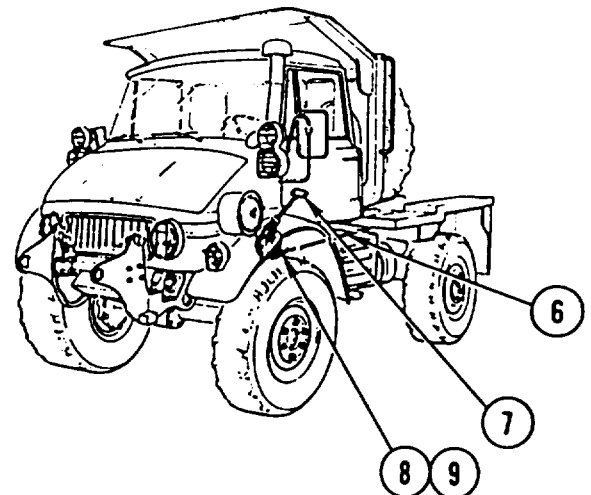
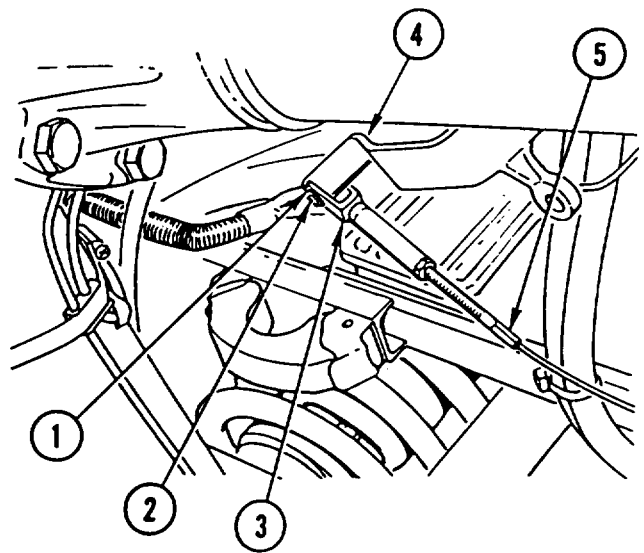

PARKING BRAKE CONTROLS REPLACEMENT (CONT)

6. REMOVE nut (10), washer (11), screw (12), and HOUSING (13).
7. FROM REAR of VEHICLE, CAREFULLY PULL CABLE (5) until it is clear of vehicle.

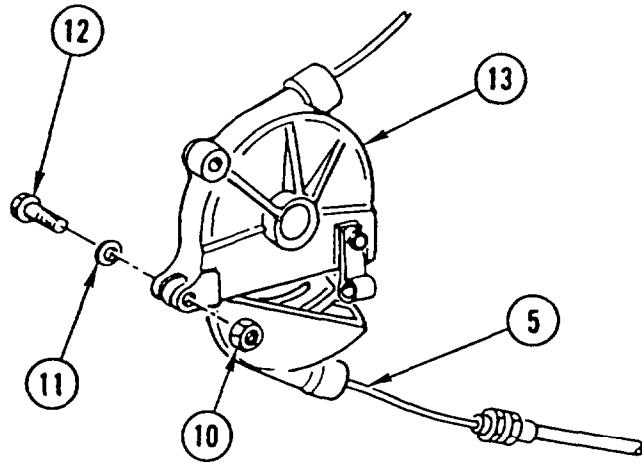

INSTALLATION

1. FROM REAR of VEHICLE, INSTALL CABLE (1) all the way up to cab.
2. INSTALL HOUSING (2), screw (3), washer (4), and nut (5).

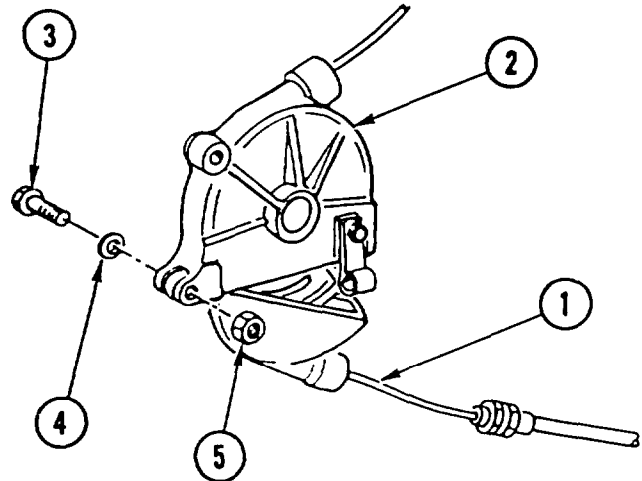

3. INSTALL hand brake (6) HANDLE on cable end (7) and TIGHTEN jam NUT (8).
4. INSTALL CABLE (1) to center mounting point (9).

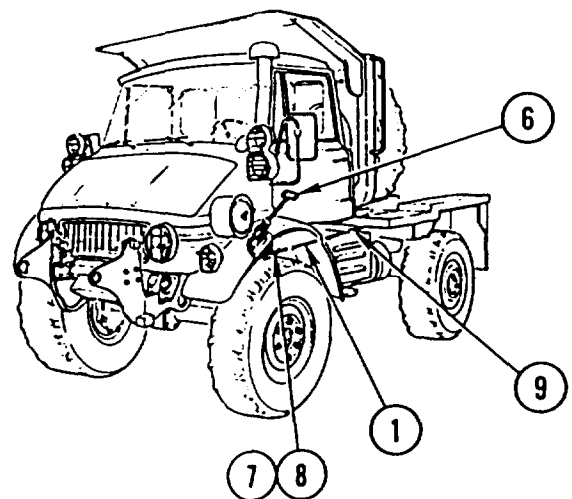

PARKING BRAKE CONTROLS REPLACEMENT (CONT)

5. At REAR of VEHICLE, INSTALL CLEVIS (10) and pin (11) on lever (12).
6. SNAP RETAINER (13) into place.

NOTE

Follow-on Maintenance:
Adjust parking brake (page 4-254).
Lower cab (page 4-418).

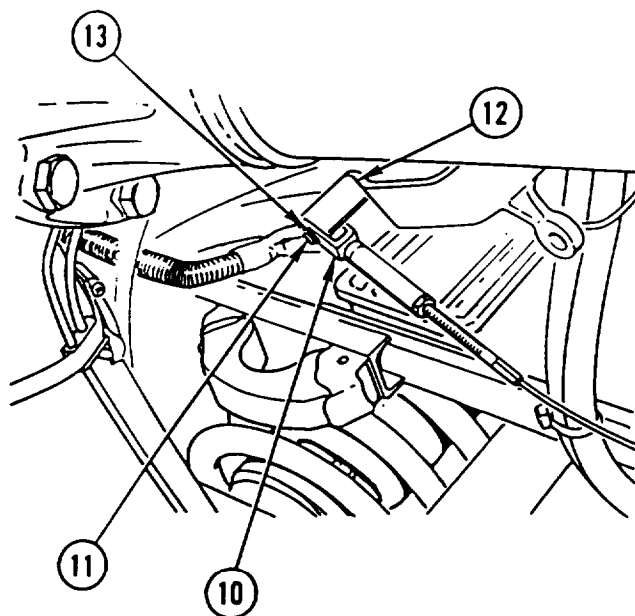

PARKING BRAKE ADJUSTMENT

This task covers: Adjustment

INITIAL SETUP

Tools and Special Equipment:

Shop Equipment, SC 4910-95-CL-A74
 Tool Kit, SC 5180-90-CL-N26

Equipment Condition:

Reference	Condition Description
Page 4-335	Rear Wheel Assembly Removed

ADJUSTMENT

NOTE

- Procedure must be performed any time rear disc brake pads are removed and/or replaced.
- Procedure is the same for both sides of rear axle.
- While adjusting, observe different turning direction on each fixed caliper.

1. Force parking brake actuating arm (1) against stop.

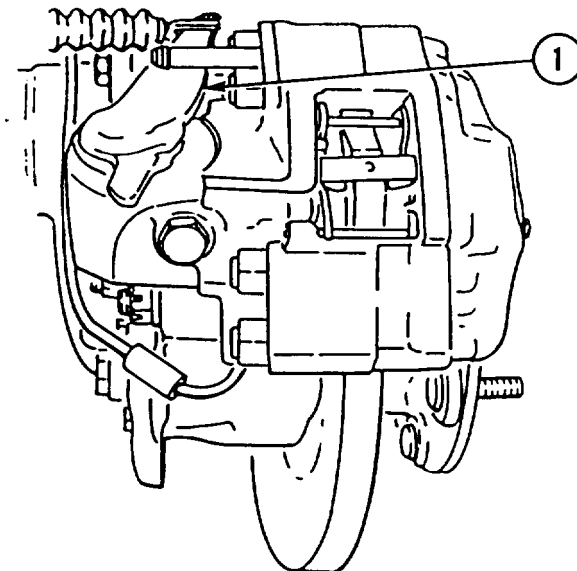

2. Loosen nut (2).

3. Refer to chart. insert feeler gage between rear disc brake pad and rotor and turn adjusting screw (3) until gap of 0.010 in. (0.25 mm) is achieved.

4. Tighten nut (2) while holding adjusting screw (3) in place.

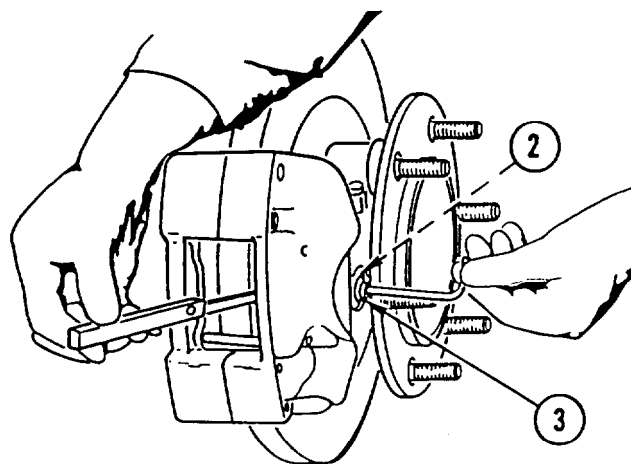

PARKING BRAKE ADJUSTMENT (CONT)

	B	C	D
LOOSEN BRAKE LINING FROM BRAKE DISC	RIGHT	LEFT	RIGHT
PUT BRAKE LINING AGAINST BRAKE DISC	LEFT	RIGHT	LEFT

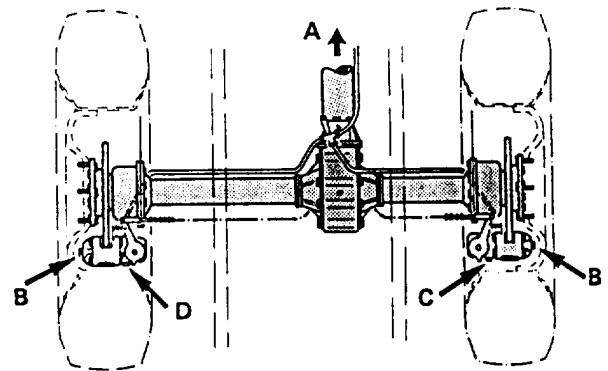

A = DRIVING DIRECTION

5. Remove plug (4) and seal (5).
6. Refer to chart. Insert feeler gage between rear disc brake pad and rotor and turn adjusting screw (6) until gap of 0.010 in. (0.25 mm) is achieved.
7. Install seal (5) and plug (4).

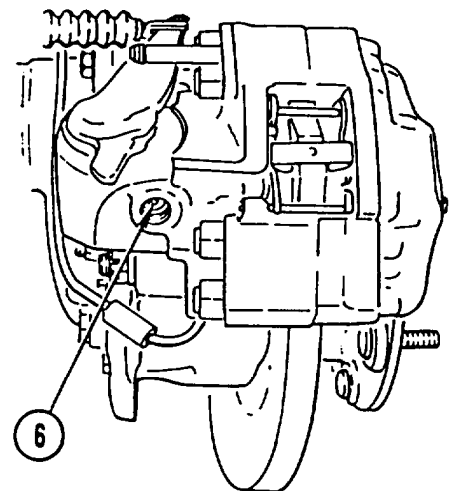
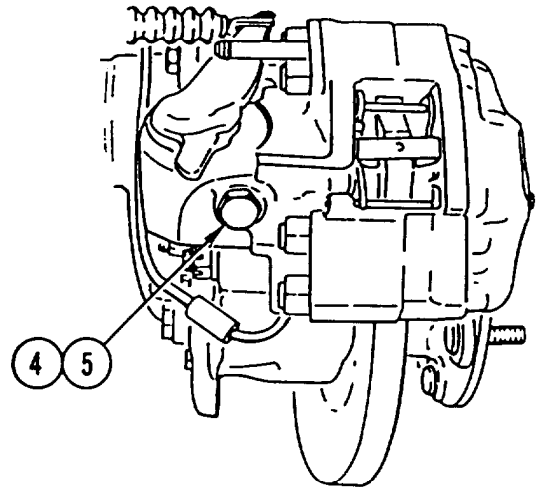

PARKING BRAKE ADJUSTMENT (CONT)

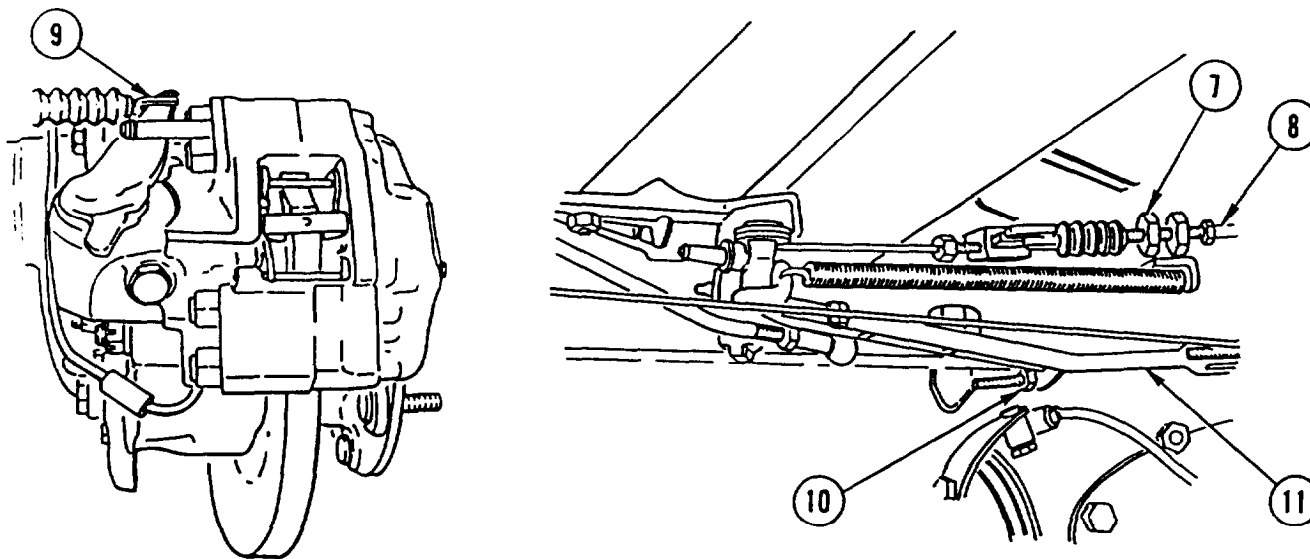

8. Turn adjusting nuts (7) on two wire rope assemblies (8) until clevises (9) are free of slack.
9. Turn adjusting nut (10) until remote control lever (11) starts to lift under tension.
10. Operate parking brake several times.

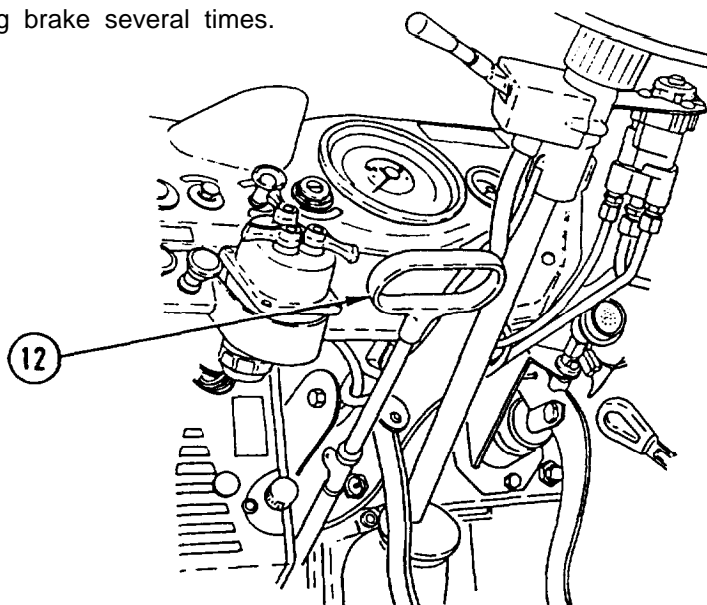

11. When properly adjusted, travel of handle (12) from released to engaged position (dimension A) should be 7.0-8.6 in. (180-220 mm).

NOTE

Follow-on Maintenance:
Install rear wheel assembly (page 4-335).

BRAKE FLUID RESERVOIR REPLACEMENT

This task covers: a. Removal b. Installation

INITIAL SETUP

Tools and Special Equipment:

Shop Equipment, SC 4910-95-CL-A74
 Tool Kit, SC 5180-90-CL-N26

Materials/Parts:

Rags Appendix C, Item 32

References:

TM 5-2420-224-10

Equipment Condition:

Reference	Condition Description
Page 4-388	Outside Engine Hood Removed

General Safety Instructions:

WARNING

- Do not connect or disconnect any electrical connector unless vehicle MASTER disconnect switch is OFF. To do so could result in injury to personnel.
- Fuel and oil are slippery and can cause falls. To avoid injury, wipe up spilled fuel or oil with rags.

REMOVAL

NOTE

Have suitable container available to catch brake fluid.

1. DISCONNECT HOSE (1) from brake fluid reservoir (2) and DRAIN into suitable container.

NOTE

Tag wires prior to disconnecting to aid in connecting.

2. Disconnect two WIRES (3 and 4) from brake fluid reservoir (2).
3. REMOVE CAP (5).
4. IF DAMAGED, REMOVE PACKING (6).
5. LOOSEN CLAMP (7) and REMOVE brake fluid RESERVOIR (2).

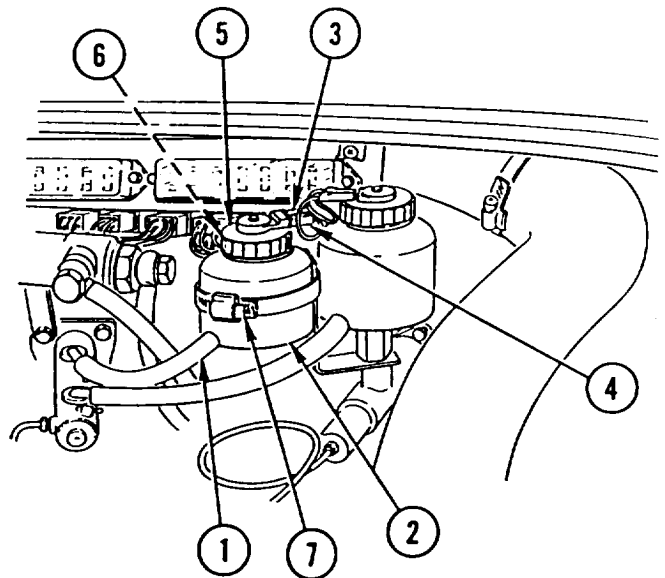

BRAKE FLUID RESERVOIR REPLACEMENT (CONT)

INSTALLATION

1. INSTALL brake fluid RESERVOIR (1).

CAUTION

Do not overtighten clamp to prevent damage to equipment.

2. TIGHTEN CLAMP (2).
3. IF REMOVED, INSTALL new PACKING (3) in cap (4).
4. INSTALL CAP (4).
5. CONNECT two WIRES (5 and 6).
6. CONNECT HOSE (7) to brake fluid reservoir (1).

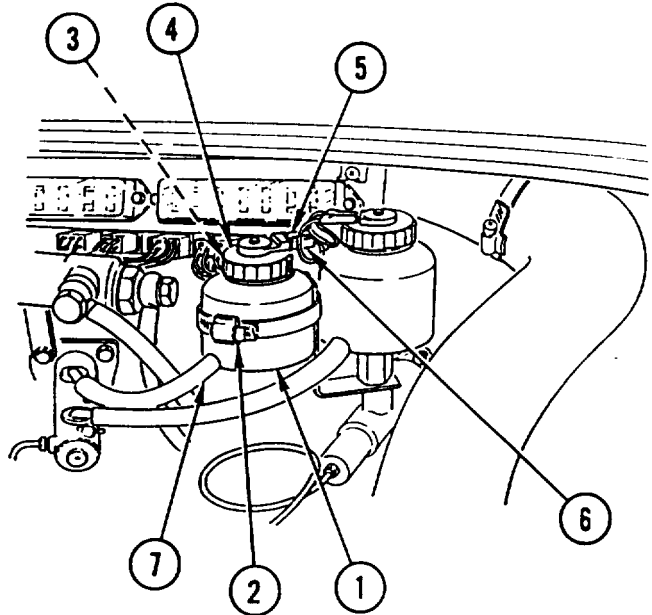

NOTE

Follow-on Maintenance:

Fill brake fluid reservoir (TM 5-2420-224-10).
Bleed brake system (page 4-262).
Install outside engine hood (page 4-388).

FRONT TRAILER COUPLING REPLACEMENT

This task covers: a. Removal b. Installation

INITIAL SETUP

Tools and Special Equipment:

Tool Kit, SC 5180-90-CL-N26

Materials/Parts:

Washer, Lock (2)

Packing (2)

Equipment Condition:

Reference	Condition Description
Page 2-23	Air Pressure Relieved

General Safety instructions:

WARNING

Do not disconnect any air system lines or fittings unless vehicle engine is shut off and air system pressure is relieved. To do so could result in injury to personnel.

REMOVAL

NOTE

Tag lines prior to disconnecting to aid in connecting.

1. Disconnect two TUBES (1).
2. REMOVE two HOLDERS (2) from between two gladhands (3) and mounting bracket (4).
3. REMOVE two elbows (5), two nuts (6), two lock washers (7), and two GLADHANDS (3) from mounting bracket (4). DISCARD lock WASHERS.
4. REMOVE two ADAPTERS (8) and two packings (9) from two gladhands (3). DISCARD PACKINGS.
5. REMOVE two nuts (10), two screws (11), and mounting BRACKET (4) from cab (12).

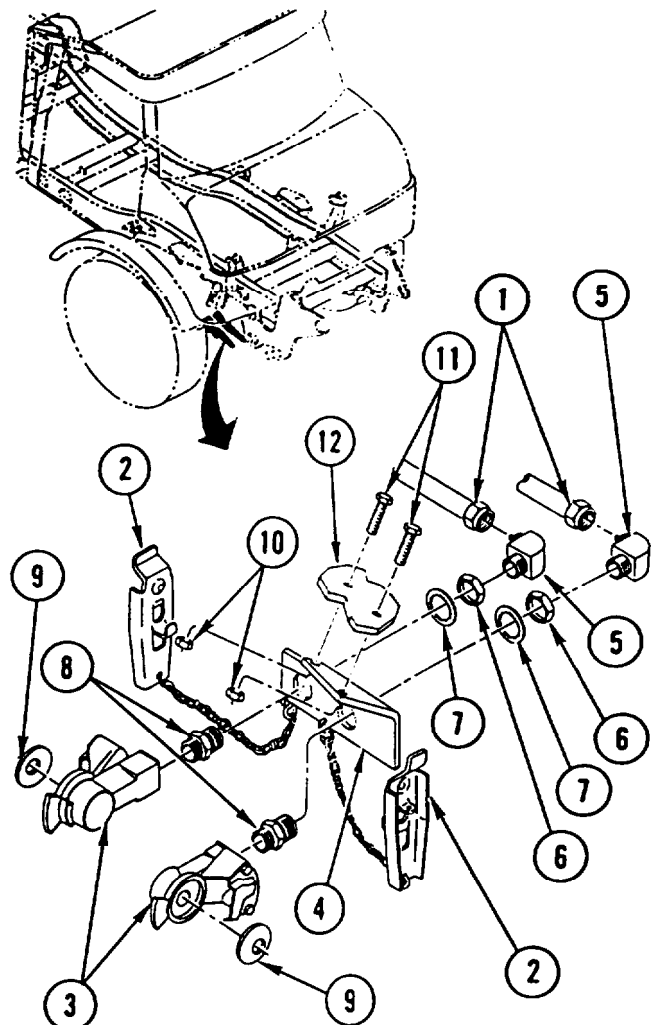

FRONT TRAILER COUPLING REPLACEMENT (CONT)

INSTALLATION

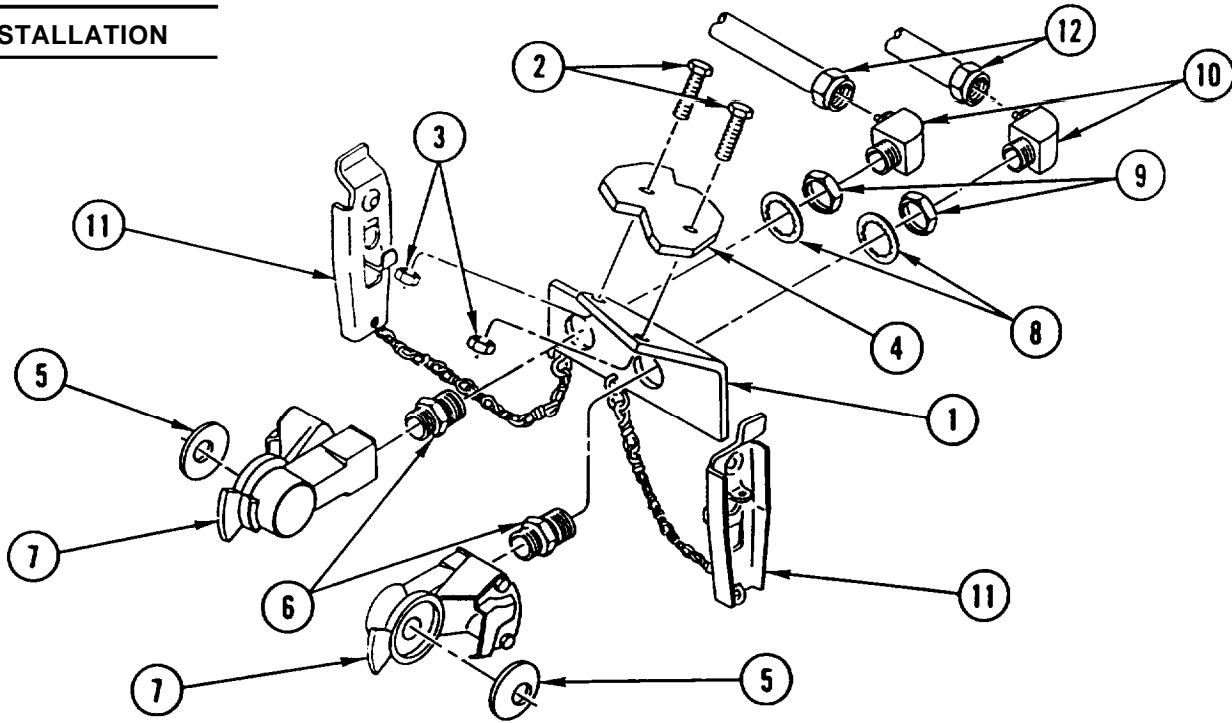

1. INSTALL mounting BRACKET (1), two screws (2), and two nuts (3) on cab (4).
2. INSTALL two new packings (5) and two ADAPTERS (6) in two gladhands (7).
3. INSTALL two GLADHANDS (7), two new lock washers (8), two nuts (9), and two elbows (10).
4. INSTALL two HOLDERS (11) between mounting bracket (1) and two gladhands (7).
5. CONNECT two TUBES (12).

PROTECTION/RELAY VALVE REPLACEMENT

This task covers: a. Removal b. Installation

INITIAL SETUP

Tools and Special Equipment:

Tool Kit, SC 5180-90 -CL-N26

Equipment Condition:

Reference	Condition Description
Page 2-23	Air Pressure Relieved

General Safety Instructions:

WARNING

Do not disconnect any air system lines or fittings unless vehicle engine is shut off and air system pressure is relieved. To do so could result in injury to personnel.

REMOVAL

NOTE

Tag lines prior to disconnecting to aid in connecting.

1. DISCONNECT three LINES (1) from valve (2).
2. REMOVE two screws (3) and VALVE (2).
3. REMOVE ADAPTER (4) and two elbows (5) from valve (2).

INSTALLATION

1. INSTALL two elbows (5) and ADAPTER (4) in valve (2).
2. INSTALL VALVE (2) and two screws (3).
3. CONNECT three LINES (1) to valve (2).

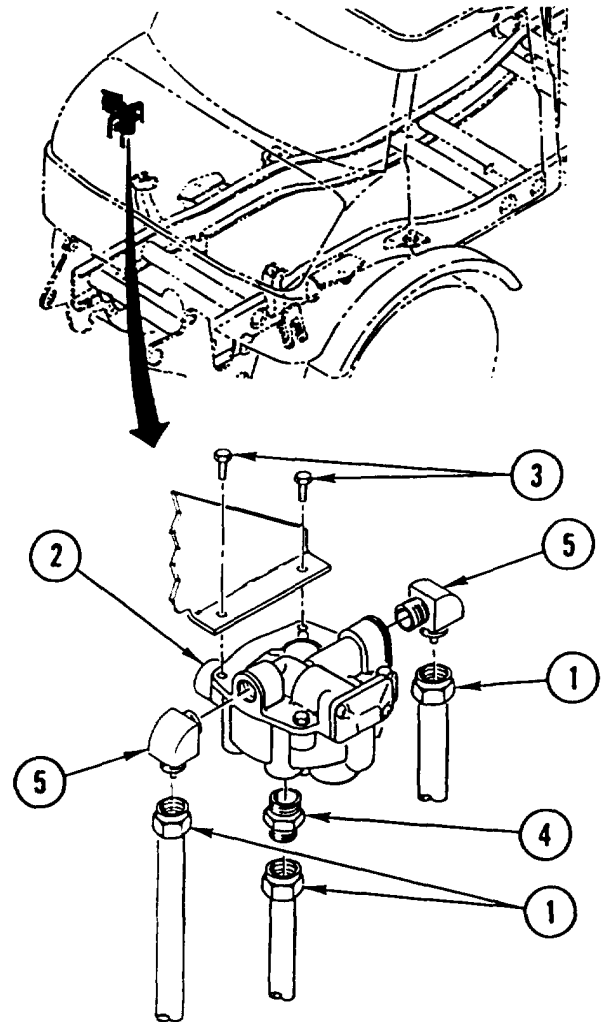

BRAKE SYSTEM BLEEDING

This task covers: Bleeding

INITIAL SETUP

Tools and Special Equipment:

Shop Equipment, SC 4910-95-CL-A74
Tool Kit, SC 5180-90-CL-N26
Elbow (2), P/N 000 589 03 25 00
Hose, P/N 000 589 02 25 00

Materials/Parts:

Fluid, Silicone Brake Appendix C, Item 15
Rags Appendix C, Item 32

Personnel Required: (2)

References:

TM 5-2420-224-10

Equipment Condition:

Reference	Condition Description
Page 4-388	Outside Engine Hood Removed

General Safety Instructions:

WARNING

Fuel and oil are slippery and can cause falls. To avoid injury, wipe up spilled fuel or oil with rags.

BLEEDING

CAUTION

Bleeding brake system by pumping brake pedal is not sufficient. Compressed air must be used to bleed brake system to prevent damage to equipment.

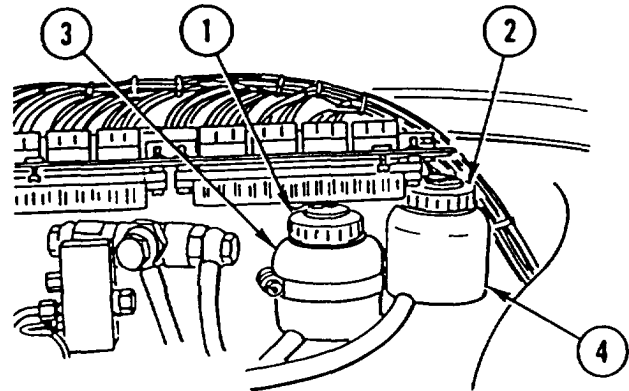

1. Remove two brake fluid reservoir caps (1 and 2) from two brake fluid reservoirs (3 and 4).

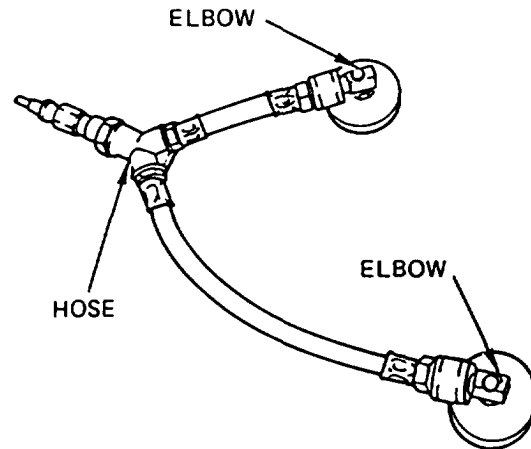

2. Install two elbows on hose.

BRAKE SYSTEM BLEEDING (CONT)

3. Install adapter assembly (5) to two brake fluid reservoirs (3 and 4).

CAUTION

Air supply must be regulated to 14.5-29.0 psi (1-2 bar) to prevent damage to equipment.

4. Connect adapter assembly (5) to air supply hose (6).

CAUTION

Brake fluid is to be considered contaminated and is not to be reused to prevent damage to equipment.

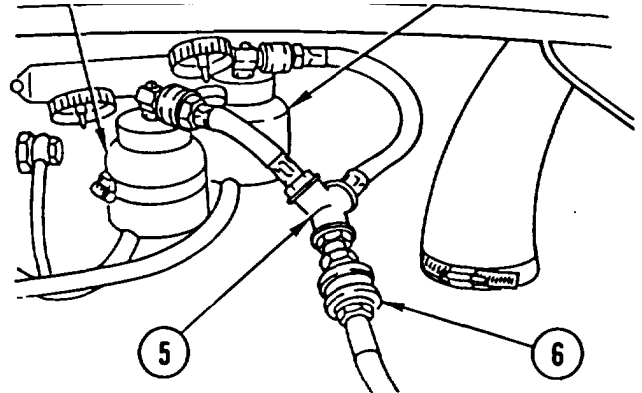

NOTE

- Use suitable container to catch brake fluid.
- Open only one bleeder valve at a time.
- Observe fluid level in brake fluid reservoirs and do not allow brake fluid to go below MIN indication before adding more fluid to reservoir.
- Brake system is considered properly bled when steady stream of brake fluid comes out of bleeder valve with no air bubbles in the stream.

5. Bleed brake system in following order:

- a. Master cylinder (7) 2 places
- b. Right rear caliper (8)
- c. Left rear caliper (9)
- d. Right rear front caliper (10)
- e. Left rear front caliper (11)
- f. ALB modulator (12)
- g. Right front caliper (13)
- h. Left front caliper (14)
- i. Clutch slave cylinder (15)

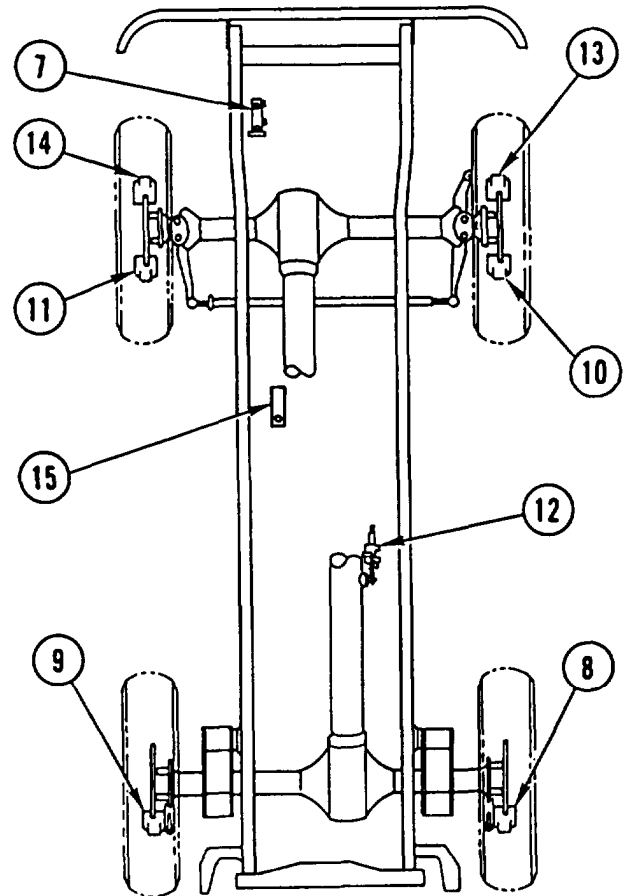

BRAKE SYSTEM BLEEDING (CONT)

6. Disconnect air supply hose (6) from adapter assembly (5).
7. Remove adapter assembly (5) from two brake fluid reservoirs (3 and 4).

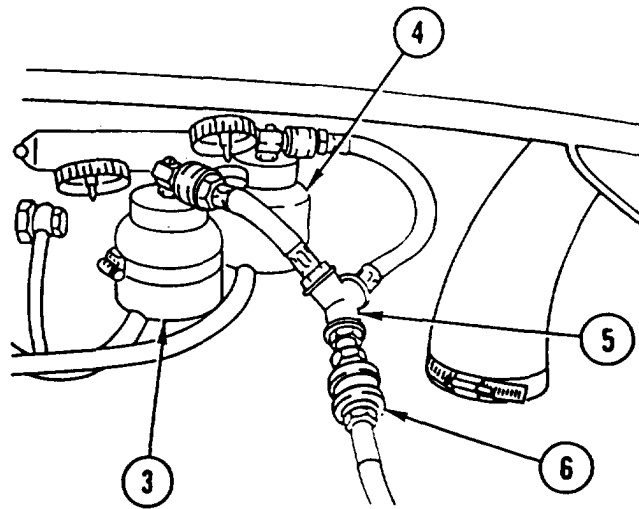

8. Remove two elbows from hose.
9. Fill two brake fluid reservoirs (3 and 4) to MAX level with brake fluid.

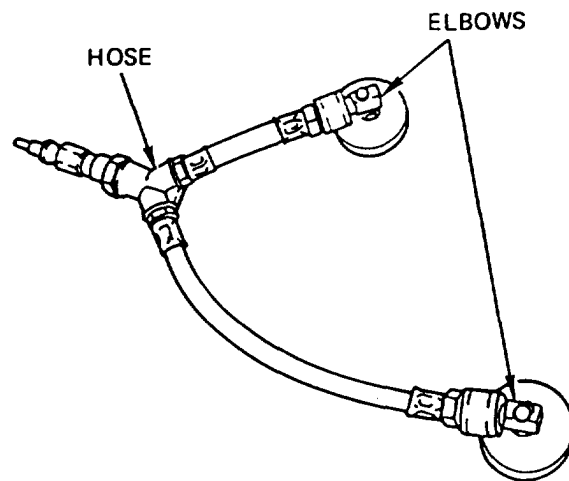

10. Install two brake fluid reservoir caps (1 and 2) on two brake fluid reservoirs (3 and 4).

NOTE

Follow-on Maintenance:
 Fill clutch hydraulic reservoir (TM 5-2420-224-10).
 Fill brake fluid reservoir (TM 5-2420-224-10).
 Install outside engine hood (page 4-388).

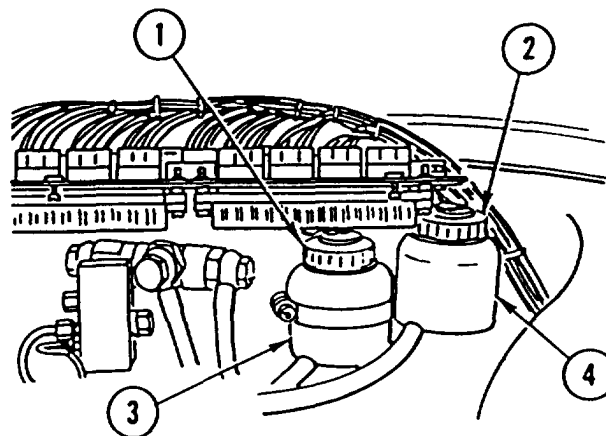

BRAKE DISC AND HUB REPLACEMENT

This task covers: a. Removal b. Inspection c. Installation

INITIAL SETUP

Tools and Special Equipment:

Shop Equipment, SC 4910-95-CL-A74
 Tool Kit, SC 5180-90-CL-N26
 Installation Tool (2), P/N 424 589 00 15 00
 Installing Tool, P/N 424 589 01 43 00
 Mandrel, P/N 406 589 04 15 00

Materials/Parts:

Spacer

Seal

References:

None

Equipment Condition:

Reference	Condition Description
Page 4-268	Rear Disc Brake Pads Removed
Page 4-271	Front Disc Brake Pads Removed

REMOVAL

NOTE

Procedure is the same for all brake discs and hubs.

1. REMOVE two SCREWS (1) and INSTALL INSTALLATION TOOLS.
2. REMOVE eight screws (1) and HUB (2).
3. WHILE SUPPORTING DISC (3), REMOVE INSTALLATION TOOLS and DISC (3).

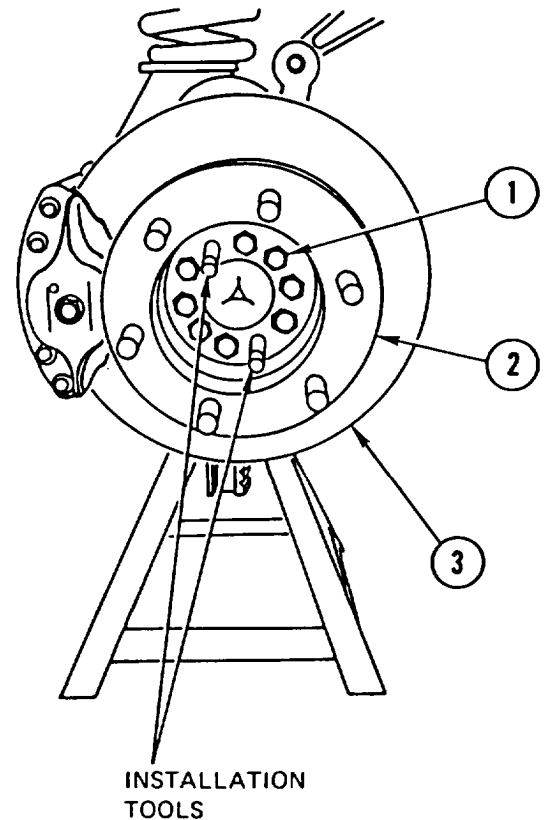

BRAKE DISC AND HUB REPLACEMENT (CONT)

4. REMOVE and DISCARD SPACER (4) and SEAL (5).

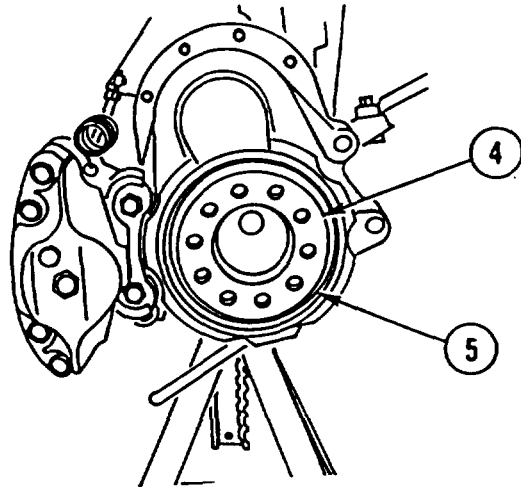

INSPECTION

If disc is gouged, measure thickness of disc at deepest gouge. Minimum acceptable thickness is 0.8 in. (20 mm).

INSTALLATION

NOTE

Procedure is the same for all brake discs and hubs.

1. USING INSTALLING TOOL and MANDREL, INSTALL new SEAL (1) and new SPACER (2) together.

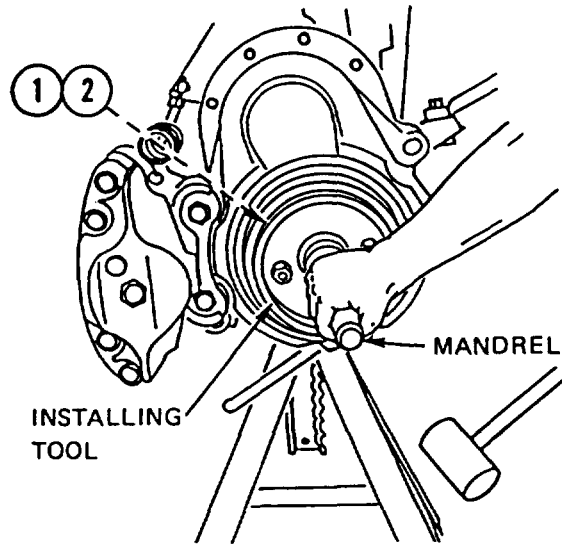

2. INSTALL DISC (3) and INSTALLATION TOOLS.

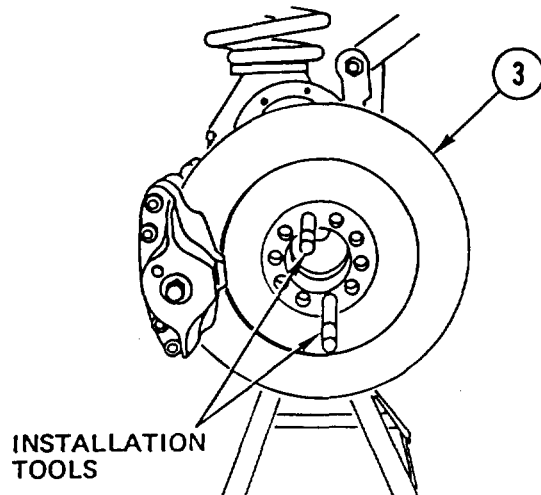

BRAKE DISC AND HUB REPLACEMENT (CONT)

3. INSTALL HUB (4) and eight screws (5).
4. REMOVE INSTALLATION TOOLS and INSTALL remaining two SCREWS (5). TIGHTEN 10 SCREWS (5) to 240 lb-ft (320 N.m).

NOTE

Follow-on Maintenance:

- Install rear disc brake pads (page 4-268).
- Install front disc brake pads (page 4-271).
- Check hub oil level (page 2-14).

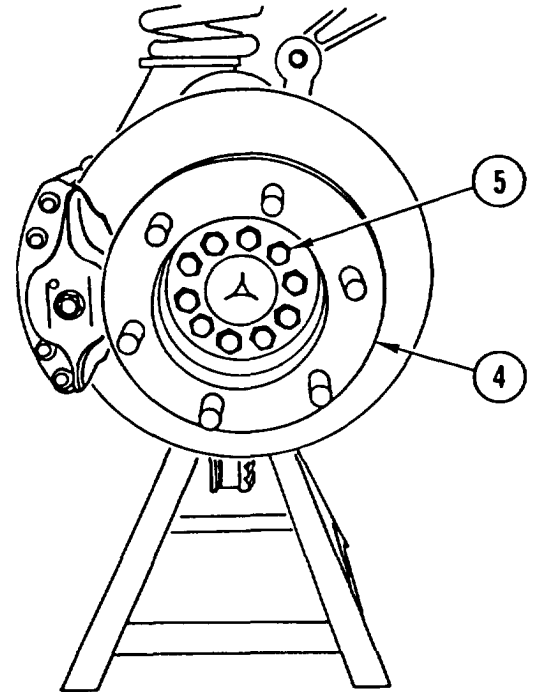

REAR DISC BRAKE PAD REPLACEMENT

This task covers: a. Removal b. Inspection c. Installation

INITIAL SETUP

Tools and Special Equipment:

Shop Equipment, SC 4910-95-CL-A74
Tool Kit, SC 5180-90-CL-N26
Puller, P/N 001 589 43 53 00
Installation Tool, P/N 000 589 52 43 00

Materials/Parts:

Kit, Parts

References:

■ TM 5-2420-224-10

Equipment Condition:

Reference

Page 4-335

TM 5-2420-224-10

Condition Description

Rear Wheel Assembly
Removed

Parking Brake
Released

REMOVAL

NOTE

Procedure is the same for both rear disc brake calipers.

1. REMOVE two pins (1 and 2) and SPRING (3).

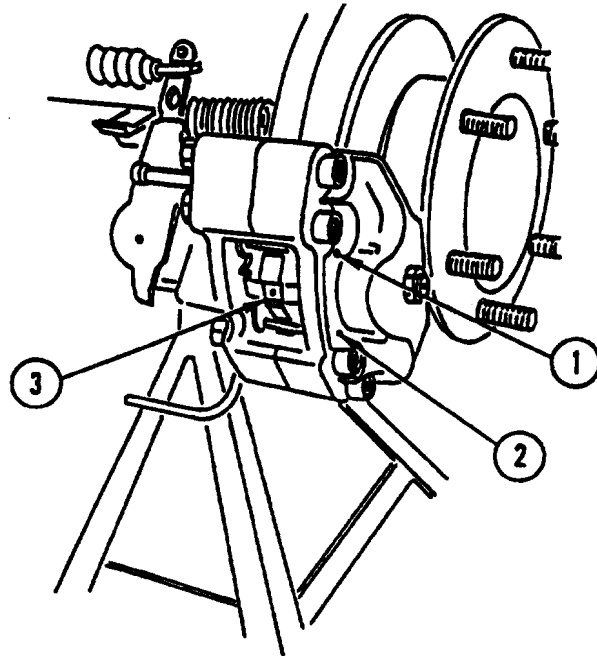

REAR DISC BRAKE PAD REPLACEMENT (CONT)

2. USING PULLER, REMOVE two brake LININGS (4 and 5).

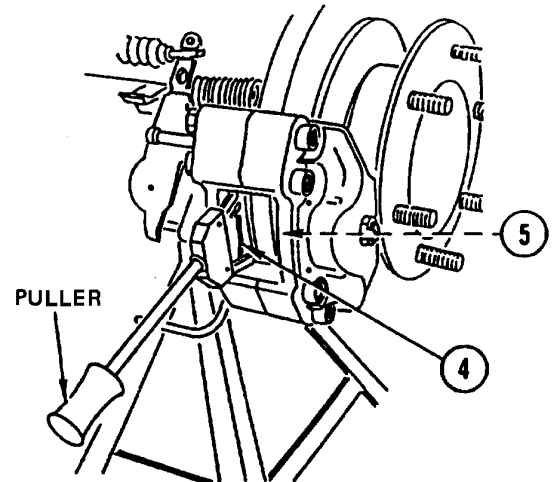

INSPECTION

Measure thickness of brake lining. Minimum acceptable thickness is 0.08 in. (2.0 mm).

INSTALLATION

NOTE

Procedure is the same for both rear disc brake calipers.

1. Back off parking brake adjustment screws, page 4-254, steps 1-7 (disregard requirement to measure gap).

- 1A. USING INSTALLATION TOOL, COLLAPSE PISTONS (1 and 2).

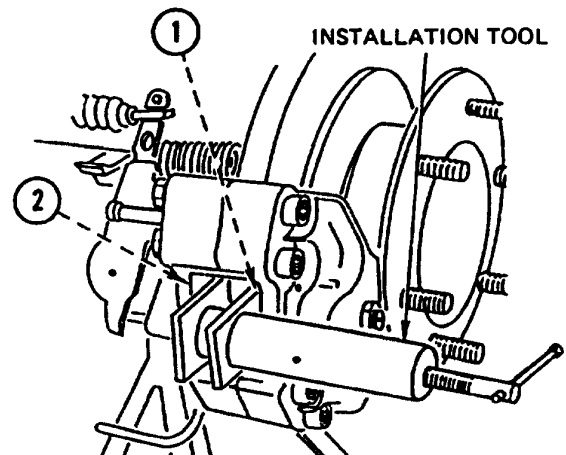
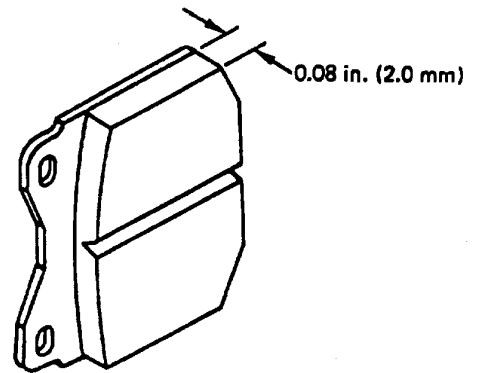

REAR DISC BRAKE PAD REPLACEMENT (CONT)

2. INSTALL two new brake LININGS (3 and 4).

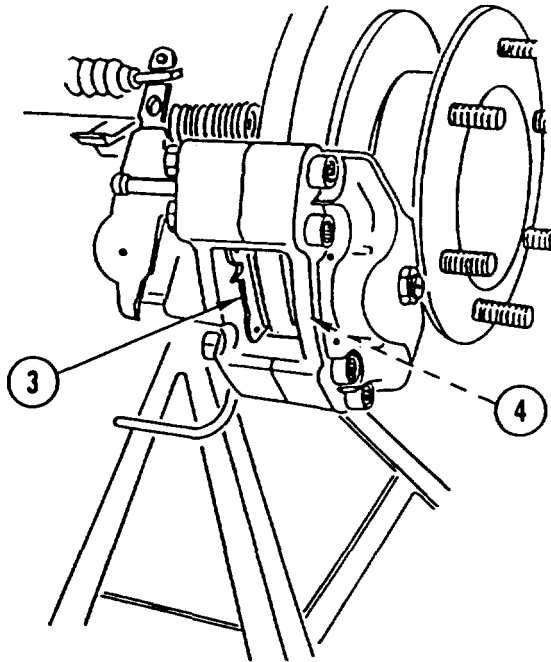

3. INSTALL SPRING (5) and two pins (6 and 7).

NOTE

Follow-on Maintenance:
Adjust parking brake (page 4-254).
Install rear wheel assembly (page 4-335).
Fill brake fluid reservoir (TM 5-2420-224-10).

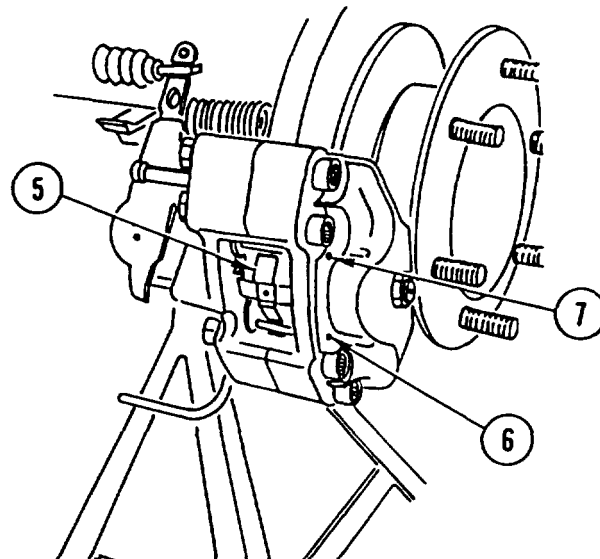

FRONT DISC BRAKE PAD REPLACEMENT

This task covers: a. Removal b. Inspection c. Installation

INITIAL SETUP

Tools and Special Equipment:

Shop Equipment, SC 4910-95-CL-A74
 Tool Kit, SC 5180-90-CL-N26
 Puller, P/N 001 589 43 53 00
 Installation Tool, P/N 000 589 52 43 00

References:

TM 5-2420-224-10

Equipment Condition:

Reference	Condition Description
Page 4-335	Front Wheel Assembly Removed

Materials/Parts:

Kit, Parts

REMOVAL

NOTE

Procedure is the same for all four front disc brake calipers.

1. REMOVE dust COVER (1).
2. DISCONNECT brake pad indicator WIRE (2).
3. REMOVE two pins (3 and 4) and SPRING (5).
4. USING PULLER, REMOVE two brake LININGS (6 and 7) and two protective plates (8 and 9).

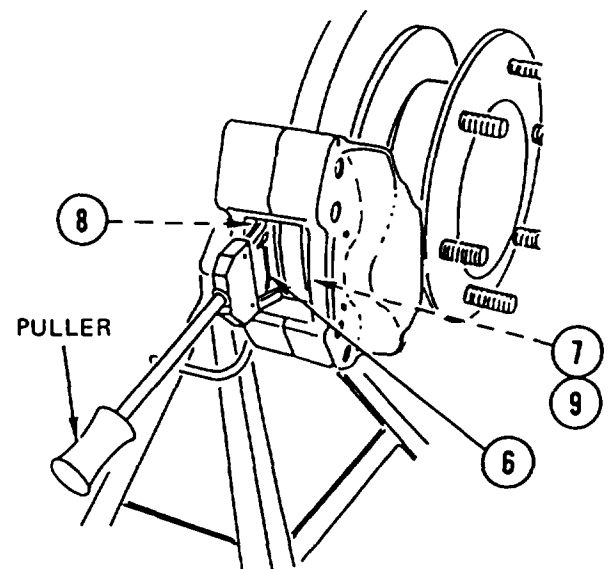
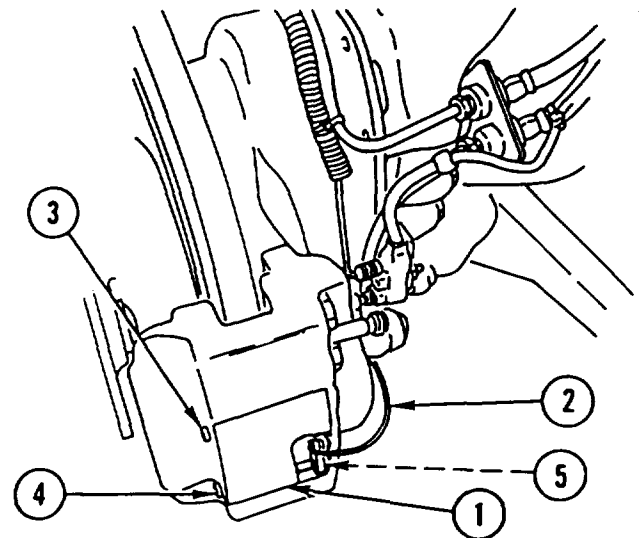

FRONT DISC BRAKE PAD REPLACEMENT (CONT)

INSPECTION

Measure thickness of brake lining. Minimum acceptable thickness is 0.08 in. (2.0 mm).

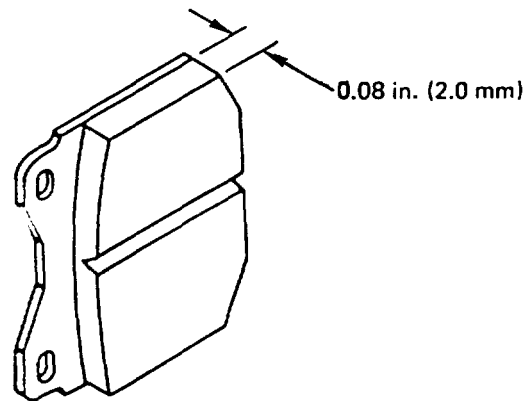

INSTALLATION

NOTE

Procedure is the same for all four front disc brake calipers.

1. USING INSTALLATION TOOL, COLLAPSE PISTONS (1 and 2).

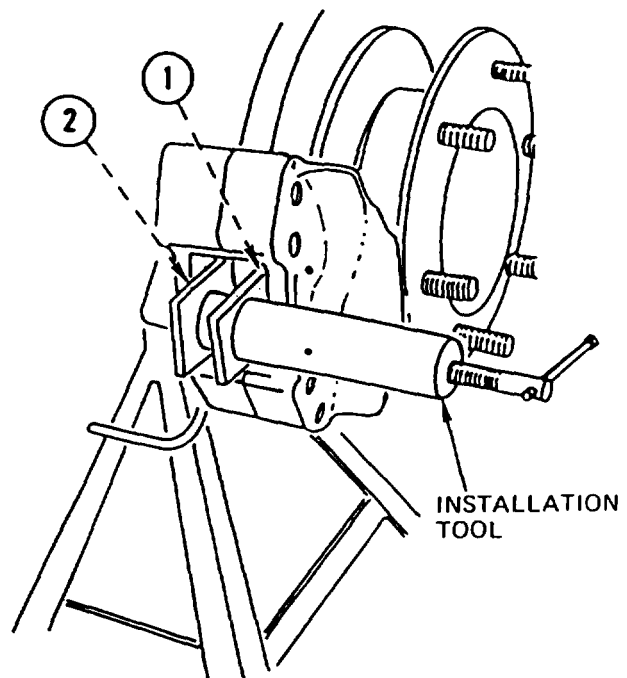

FRONT DISC BRAKE PAD REPLACEMENT (CONT)

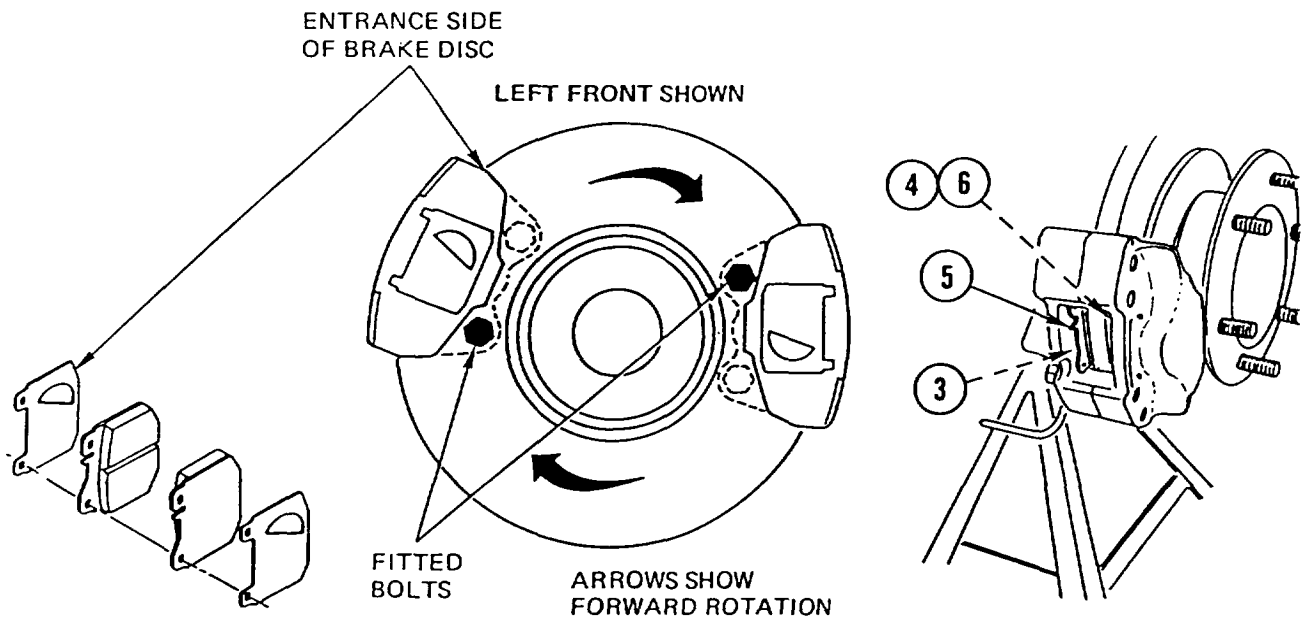

CAUTION

Make sure openings on protective plates are in same position on both sides of brake linings to prevent damage to caliper piston seals.

2. INSTALL two protective plates (3 and 4) and two new brake LININGS (5 and 6).

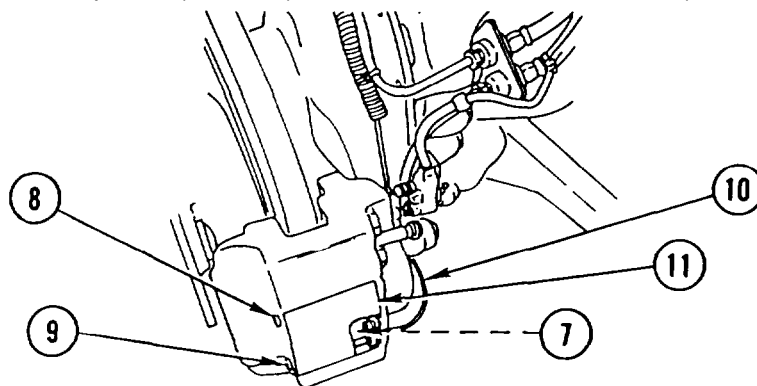

3. INSTALL SPRING (7) and two pins (8 and 9).
4. CONNECT brake pad indicator WIRE (10).
5. INSTALL dust COVER (11).

NOTE

Follow-on Maintenance:

- Install front wheel assembly (page 4-335).
- Fill clutch hydraulic reservoir (TM 5-2420-224-10).
- Fill brake fluid reservoir (TM 5-2420-224-10).

BRAKE CALIPER REPLACEMENT

This task covers: a. Removal b. Installation

INITIAL SETUP

Tools and Special Equipment:

Shop Equipment, SC 4910-95-CL-A74
Tool Kit, SC 5180-90-CL-N26
Wrench, P/N 000 589 51 03 00

Equipment Condition:

Reference

Page 4-265

Condition Description

Brake Disc and Hub
Removed

Materials/Parts:

Screw, Fitted

Washer, Lock (2)

References:

TM 5-2420-224-10

REMOVAL

NOTE

Procedure is the same for all brake calipers (except step 1).

1. REMOVE nut (1), screw (2), and parking brake CABLE (3) on rear brake caliper (4).
2. USING WRENCH, DISCONNECT brake LINE (5).
3. REMOVE fitted screw (6), standard screw (7), two nuts (8), two washers (9), two lock washers (10), and brake CALIPER (4). DISCARD fitted SCREW, WASHERS, and lock WASHERS.

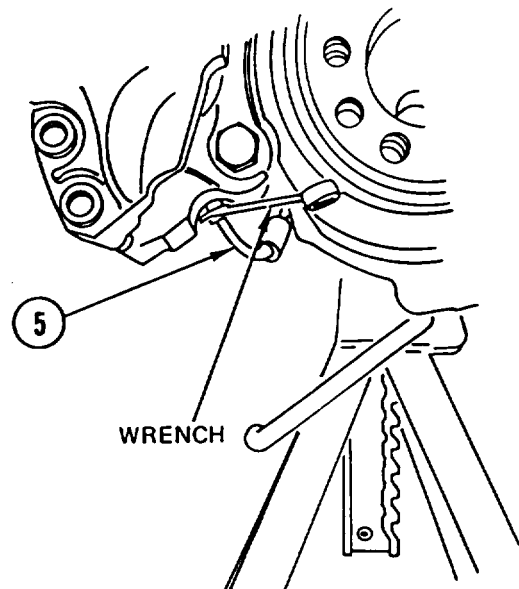
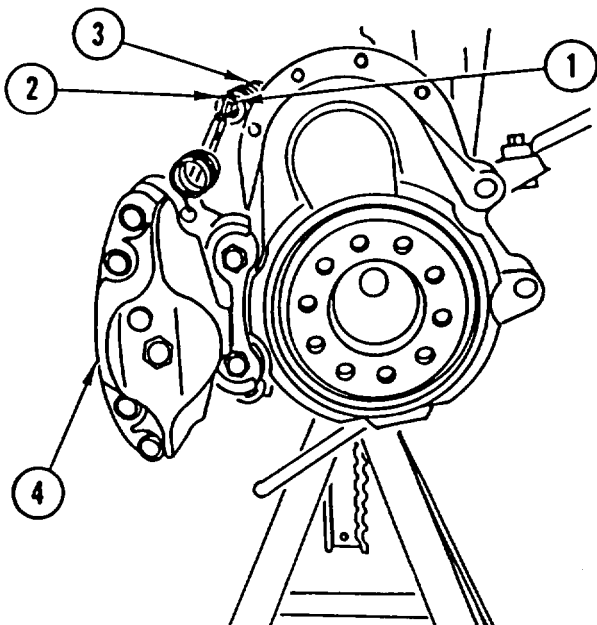

BRAKE CALIPER REPLACEMENT (CONT)

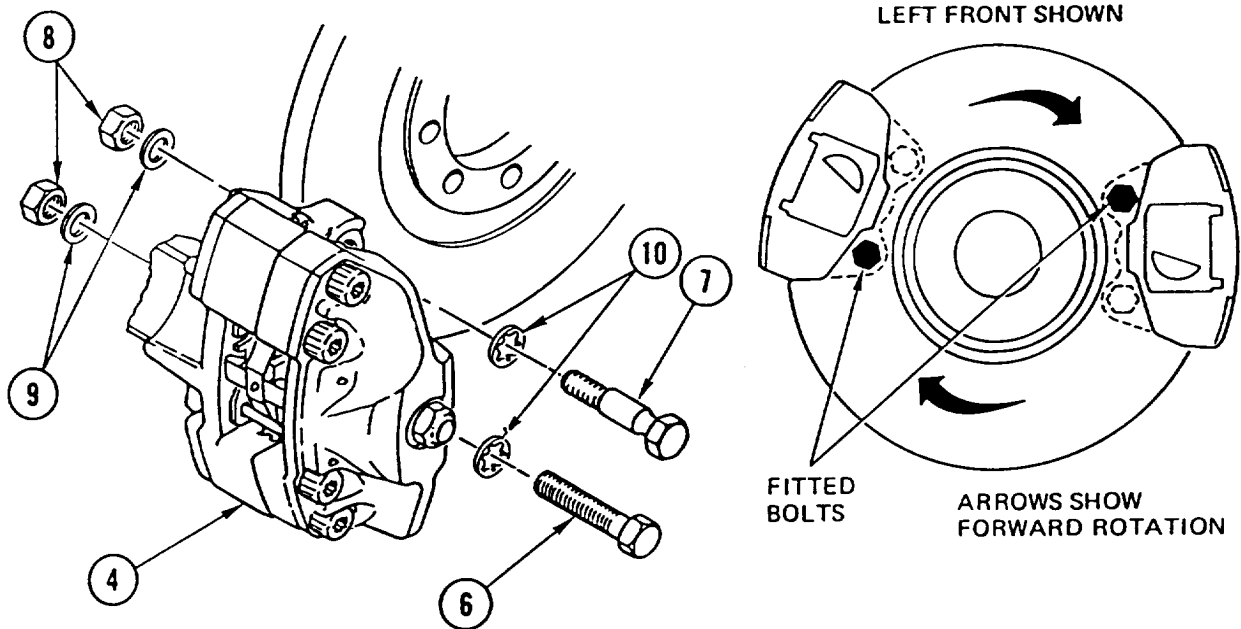

INSTALLATION

CAUTION

When installing fitted screw in brake caliper, make sure it is new. Never use fitted screw twice to prevent damage to equipment.

NOTE

- Procedure is the same for all brake calipers (except step 3).
- Insert new fitted screw on brake caliper on entrance side of brake disc.
- Washers (9) are no longer used.

1. INSTALL brake CALIPER (4), new fitted screw (6), standard screw (7), two new lock washers (10), and two nuts (8). TIGHTEN SCREWS to 185 lb-ft (250 N.m).
2. USING WRENCH, CONNECT brake LINE (5).
3. INSTALL parking brake CABLE (3), screw (2), and nut (1) on rear brake caliper (4).

NOTE

Follow-on Maintenance:

- Install brake disc and hub (page 4-265).
- Fill clutch hydraulic reservoir (TM 5-2420-224-10).
- Fill brake fluid reservoir (TM 5-2420-224-10).
- Bleed brake system (page 4-262).

BRAKE MASTER CYLINDER REPLACEMENT

This task covers: a. Removal b. Installation

INITIAL SETUP

Tools and Special Equipment:

Shop Equipment, SC 4910-95-CL-A74
Tool Kit, SC 5180-90-CL-N26
Wrench, P/N 000 589 51 03 00

Materials/Parts:

Washer, Spring
Tension (3)

Rags

Appendix C, Item 32

References:

TM 5-2420-224-10

Equipment Condition:

Reference

Page 4-388

Page 2-22

Condition Description

Outside Engine Hood
Removed

Vehicle Blocked

General Safety Instructions:

WARNING

Fuel and oil are slippery and can cause falls. To avoid injury, wipe up spilled fuel or oil with rags.

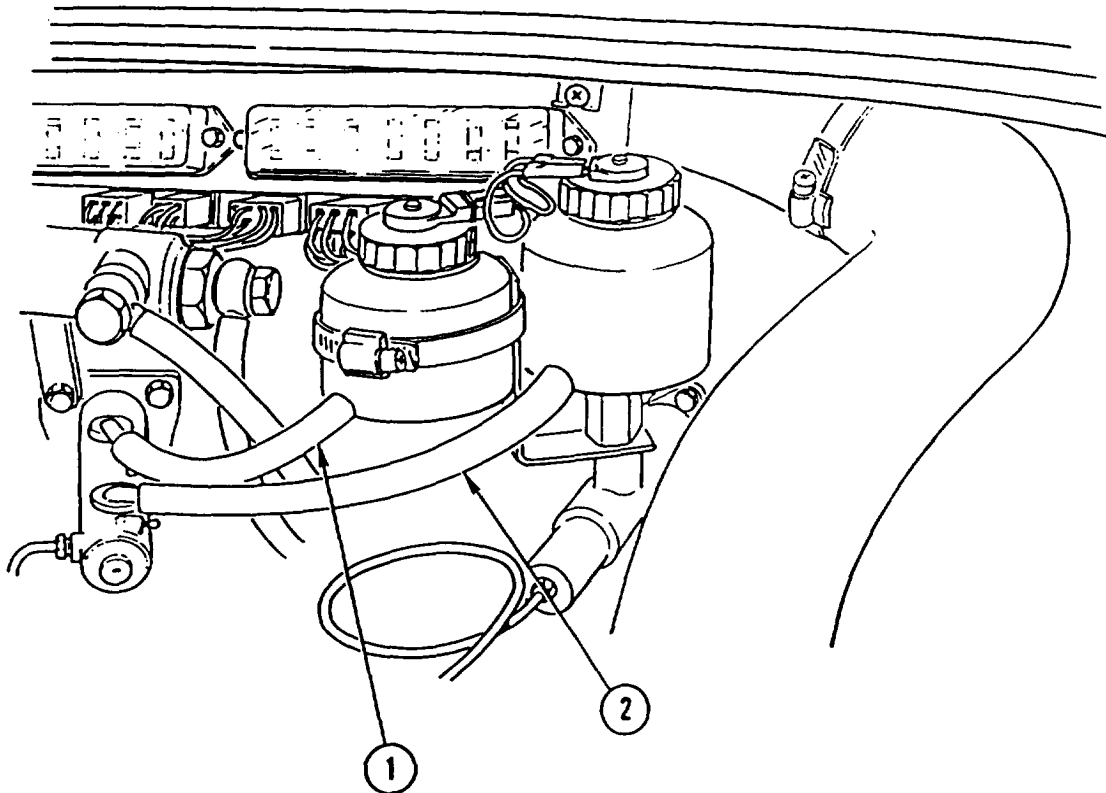

BRAKE MASTER CYLINDER REPLACEMENT (CONT)

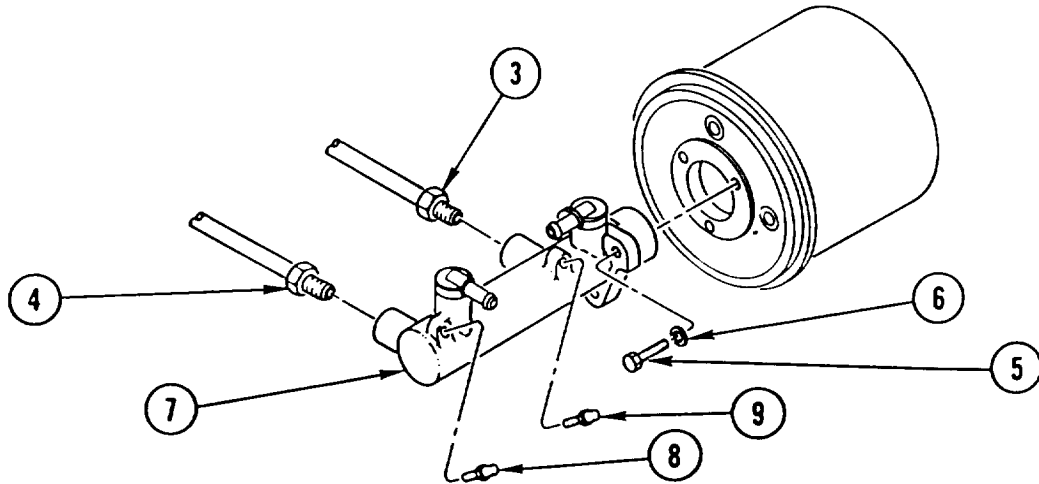

REMOVAL

1. SET parking BRAKE.

NOTE

- Tag lines prior to disconnecting to aid in connecting.
- Have suitable container available to catch brake fluid.

2. DISCONNECT brake fluid reservoir HOSE (1) and clutch hydraulic reservoir HOSE (2). DRAIN each HOSE into suitable container.
3. USING WRENCH, DISCONNECT two brake line FITTINGS (3 and 4).
4. REMOVE three screws (5), three spring tension washers (6), and brake master CYLINDER (7). DISCARD spring tension WASHERS.
5. REMOVE two bleeder VALVES (8 and 9).

INSTALLATION

1. INSTALL two bleeder VALVES (8 and 9).
2. INSTALL brake master CYLINDER (7), three screws (5), and three new spring tension washers (6).
3. USING WRENCH, CONNECT two brake line FITTINGS (3 and 4).
4. CONNECT two HOSES (1 and 2).

NOTE

Follow-on Maintenance:

- Fill clutch hydraulic reservoir (TM 5-2420-224-10).
- Fill brake fluid reservoir (TM 5-2420-224-10).
- Bleed brake system (page 4-262).
- Adjust brake pedal (page 4-287).
- Install outside engine hood (page 4-388).

REAR BRAKE CALIPERS HYDRAULIC LINES AND FITTINGS REPLACEMENT

This task covers: a. Removal b. Installation

INITIAL SETUP

Tools and Special Equipment:

Shop Equipment, SC 4910-95-CL-A74
Tool Kit, SC 5180-90-CL-N26
Wrench, P/N 000 589 51 03 00

Materials/Parts:

Rags Appendix C, Item 32

References:

TM 5-2420-224-10

General Safety Instructions:

WARNING

Fuel and oil are slippery and can cause falls. To avoid injury, wipe up spilled fuel or oil with rags.

REMOVAL

NOTE

Tag lines prior to removal to aid in installation.

REMOVE rear brake calipers hydraulic LINES and FITTINGS using illustration and legend as a guide.

INSTALLATION

INSTALL rear brake calipers hydraulic LINES and FITTINGS using illustration and legend as a guide.

NOTE

Follow-on Maintenance:

Fill clutch hydraulic reservoir (TM 5-2420-224-10).

Fill brake fluid reservoir (TM 5-2420-224-10).

Bleed brake system (page 4-262).

**REAR BRAKE CALIPERS HYDRAULIC LINES AND FITTINGS
REPLACEMENT (CONT)**

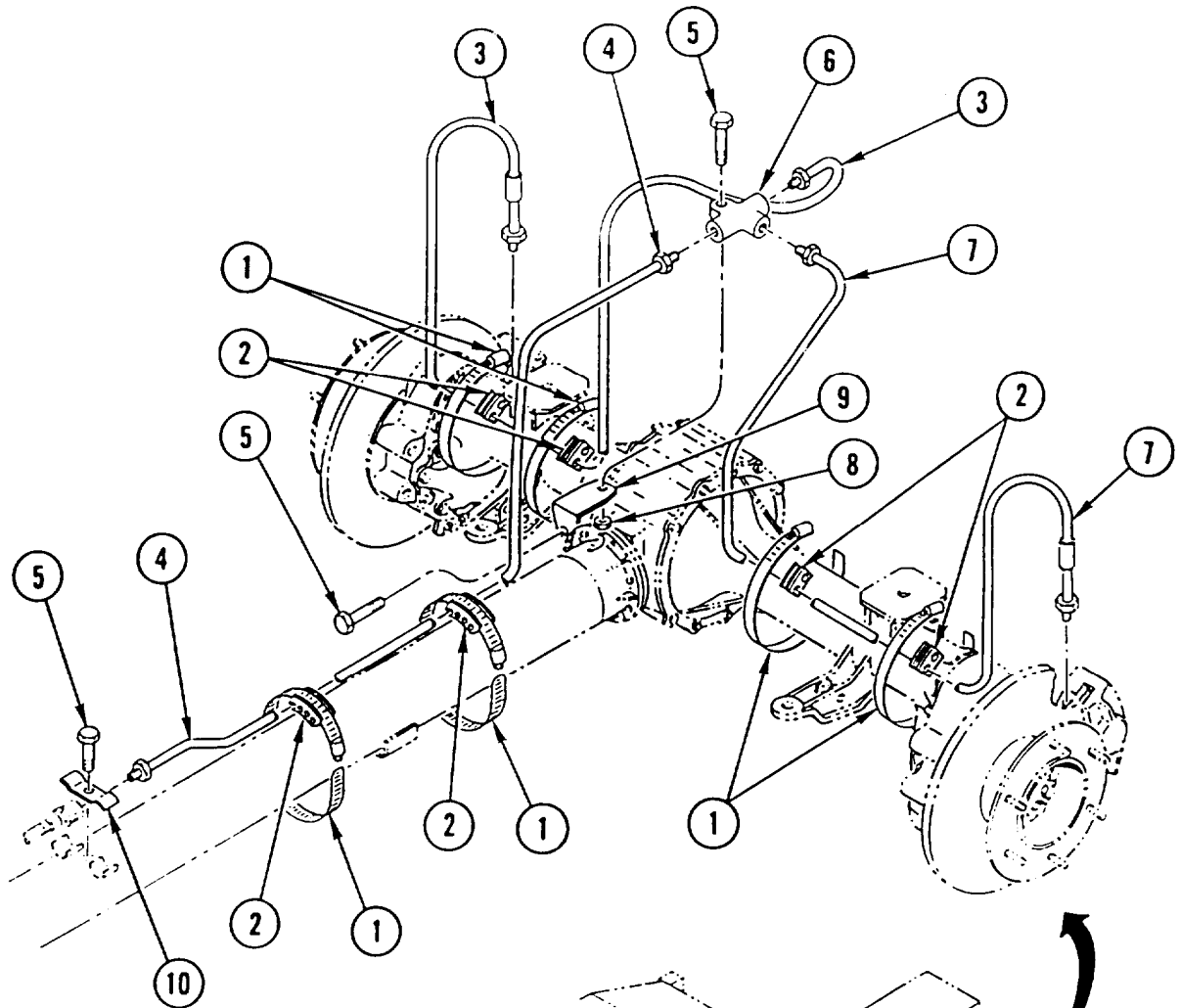

LEGEND

- 1 Clamp (6)
- 2 Clamp (6)
- 3 Tube assembly
- 4 Tube assembly
- 5 Screw (3)
- 6 Distributor
- 7 Tube assembly
- 8 Nut
- 9 Bracket
- 10 Clamp

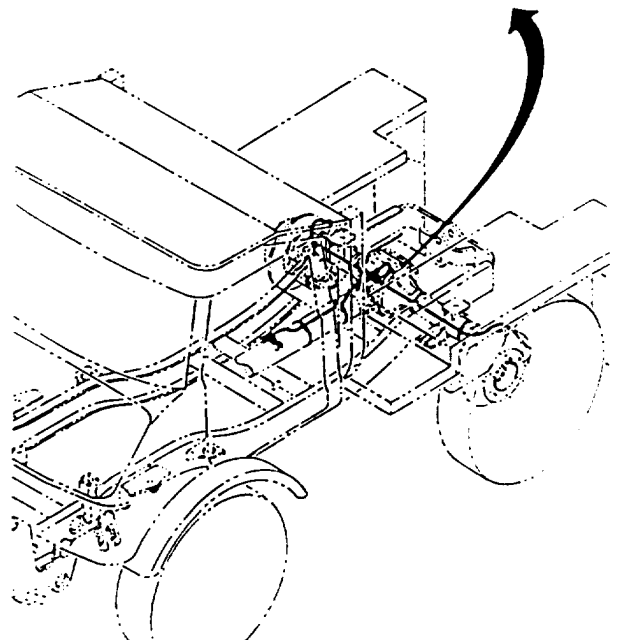

BRAKE MASTER CYLINDER HYDRAULIC LINES AND FITTINGS REPLACEMENT

This task covers: a. Removal b. Installation

INITIAL SETUP

Tools and Special Equipment:

Shop Equipment, SC 4910-95-CL-A74
Tool Kit, SC 5180-90-CL-N26
Wrench, P/N 000 589 51 03 00

General Safety Instructions:

WARNING

Fuel and oil are slippery and can cause falls. To avoid injury, wipe up spilled fuel or oil with rags.

Materials/Parts:

Rags **Appendix C, Item 32**

References:

TM 5-2420-224-10

REMOVAL

NOTE

Tag lines prior to removal to aid in installation.

REMOVE brake master cylinder hydraulic LINES and FITTINGS using illustration and legend as a guide.

INSTALLATION

INSTALL brake master cylinder hydraulic LINES and FITTINGS using illustration and legend as a guide.

NOTE

Follow-on Maintenance:

Fill clutch hydraulic reservoir (TM 5-2420-224-10).

Fill brake fluid reservoir (TM 5-2420-224-10).

Bleed brake system (page 4-262).

**BRAKE MASTER CYLINDER HYDRAULIC LINES AND FITTINGS
REPLACEMENT (CONT)**

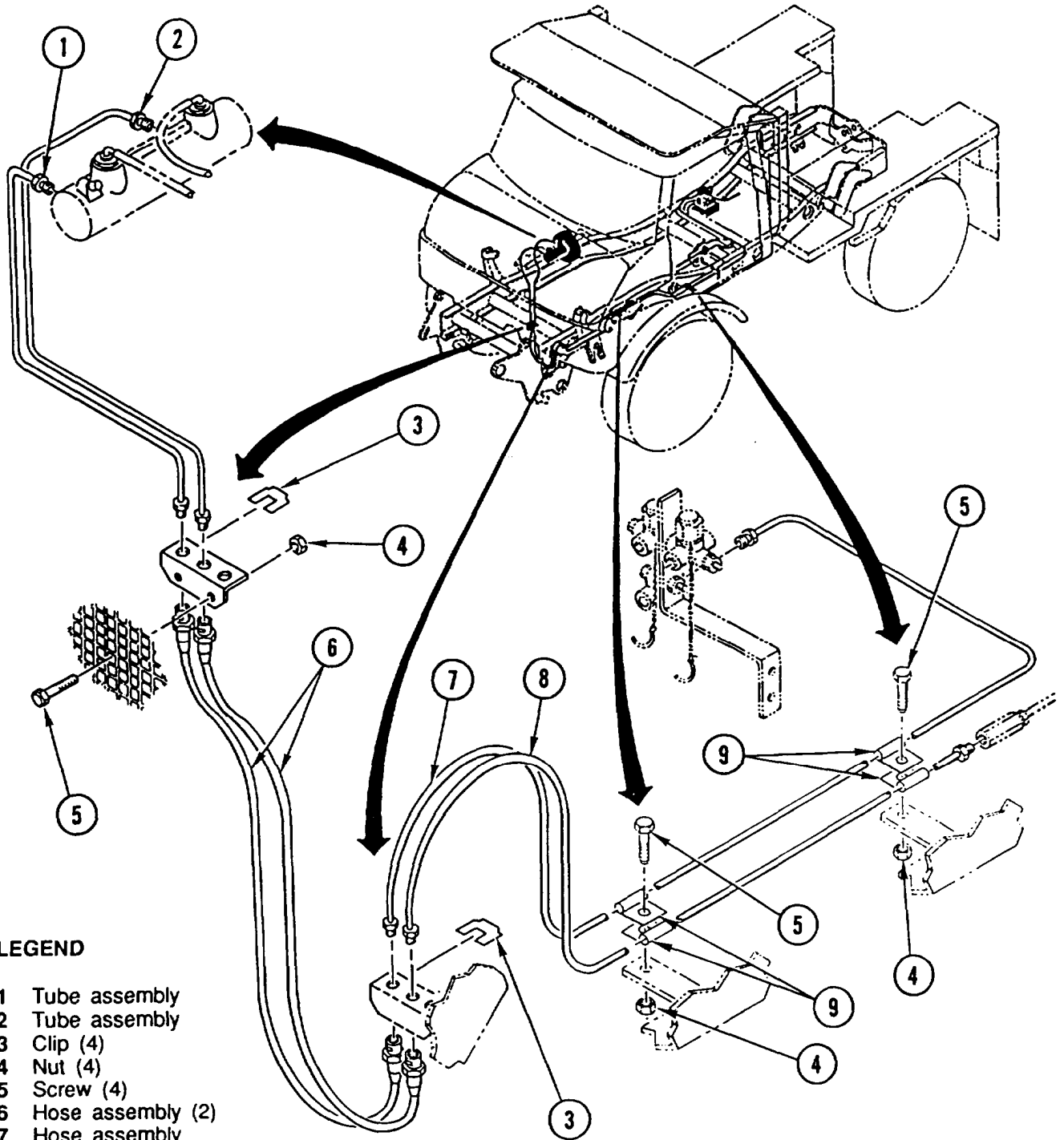

LEGEND

- 1 Tube assembly
- 2 Tube assembly
- 3 Clip (4)
- 4 Nut (4)
- 5 Screw (4)
- 6 Hose assembly (2)
- 7 Hose assembly
- 8 Hose assembly
- 9 Clamp (4)

BRAKE PRESSURE REGULATOR (ALB VALVE) LINES AND FITTINGS REPLACEMENT

This task covers: a. Removal b. Installation

INITIAL SETUP

Tools and Special Equipment:

Shop Equipment, SC 4910-95-CL-A74
Tool Kit, SC 5180-90-CL-N26
Wrench, P/N 000 589 51 03 00

General Safety Instructions:

WARNING

Fuel and oil are slippery and can cause falls. To avoid injury, wipe up spilled fuel or oil with rags.

Materials/Parts:

Seal (AR)

Rags Appendix C, Item 32

References:

TM 5-2420-224-10

REMOVAL

NOTE

- Tag lines prior to removal to aid in installation.
- Discard seal(s).

REMOVE brake pressure regulator (ALB valve) LINES and FITTINGS using illustration and legend as a guide.

INSTALLATION

NOTE

Install new seal(s).

INSTALL brake pressure regulator (ALB valve) LINES and FITTINGS using illustration and legend as a guide.

NOTE

Follow-on Maintenance:

Fill clutch hydraulic reservoir (TM 5-2420-224-10).
Fill brake fluid reservoir (TM 5-2420-224-10).
Bleed brake system (page 4-262).

BRAKE PRESSURE REGULATOR (ALB VALVE) LINES AND FITTINGS REPLACEMENT (CONT)

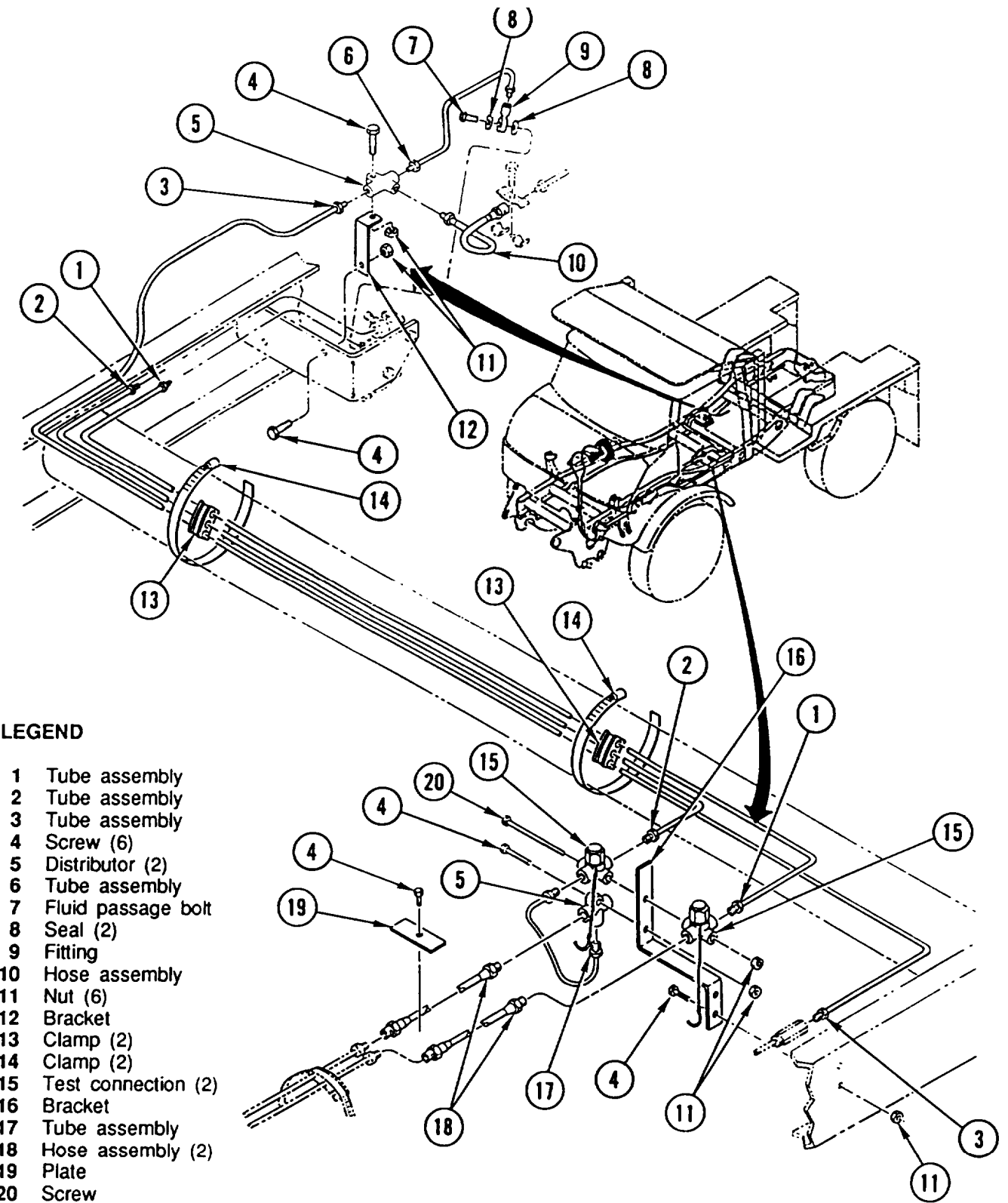

LEGEND

- 1 Tube assembly
- 2 Tube assembly
- 3 Tube assembly
- 4 Screw (6)
- 5 Distributor (2)
- 6 Tube assembly
- 7 Fluid passage bolt
- 8 Seal (2)
- 9 Fitting
- 10 Hose assembly
- 11 Nut (6)
- 12 Bracket
- 13 Clamp (2)
- 14 Clamp (2)
- 15 Test connection (2)
- 16 Bracket
- 17 Tube assembly
- 18 Hose assembly (2)
- 19 Plate
- 20 Screw

FRONT BRAKE CALIPERS HYDRAULIC LINES AND FITTINGS REPLACEMENT

This task covers: a. Removal b. Installation

INITIAL SETUP

Tools and Special Equipment:

Shop Equipment, SC 4910-95-CL-A74
Tool Kit, SC 5180-90-CL-N26
Wrench, P/N 000 589 51 03 0

Materials/Parts:

Rags Appendix C, item 32

References:

TM 5-2420-224-10

General Safety Instructions:

WARNING

Fuel and oil are slippery and can cause falls. To avoid injury, wipe up spilled fuel or oil with rags.

REMOVAL

NOTE

Tag lines prior to removal to aid in installation.

REMOVE front brake calipers hydraulic LINES and FITTINGS using illustration and legend as a guide.

INSTALLATION

INSTALL front brake calipers hydraulic LINES and FITTINGS using illustration and legend as a guide.

NOTE

Follow-on Maintenance:

Fill clutch hydraulic reservoir (TM 5-2420-224-10).
Fill brake fluid reservoir (TM 5-2420-224-10).
Bleed brake system (page 4-262).

**FRONT BRAKE CALIPERS HYDRAULIC LINES AND FITTINGS
REPLACEMENT (CONT)**

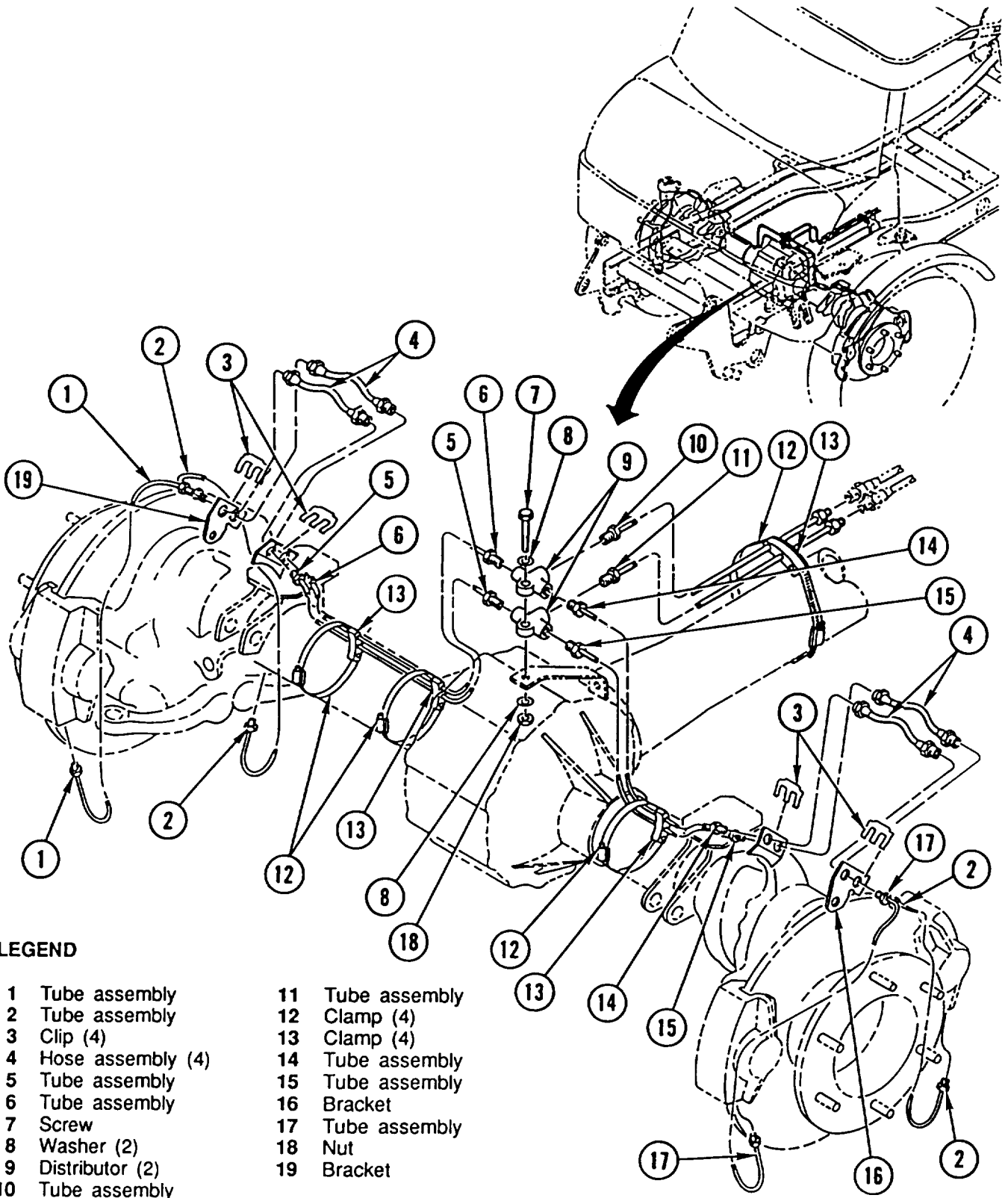

LEGEND

- | | |
|---------------------|------------------|
| 1 Tube assembly | 11 Tube assembly |
| 2 Tube assembly | 12 Clamp (4) |
| 3 Clip (4) | 13 Clamp (4) |
| 4 Hose assembly (4) | 14 Tube assembly |
| 5 Tube assembly | 15 Tube assembly |
| 6 Tube assembly | 16 Bracket |
| 7 Screw | 17 Tube assembly |
| 8 Washer (2) | 18 Nut |
| 9 Distributor (2) | 19 Bracket |
| 10 Tube assembly | |

BRAKE PEDAL REPLACEMENT

This task covers: a. Removal b. Installation

INITIAL SETUP

Tools and Special Equipment:

Tool Kit, SC 5180-90-CL-N26

Materials/Parts:

Washer, Lock

Washer, Lock

Equipment Condition:

Reference

Page 2-22

Condition Description

Vehicle Blocked

REMOVAL

1. REMOVE nut (1), lock washer (2), SPRING (3), bushing (4), and screw (5). DISCARD lock WASHER.
2. REMOVE nut (6), lock washer (7), two bushings (8 and 9), eccentric bolt (10), and brake PEDAL (11). DISCARD lock WASHER.

INSTALLATION

1. INSTALL brake PEDAL (11), eccentric bolt (10), two bushings (8 and 9), new lock washer (7), and nut (6).
2. INSTALL screw (5), bushing (4), SPRING (3), new lock washer (2), and nut (1).

NOTE

Follow-on Maintenance:
Adjust brake pedal (page 4-287).

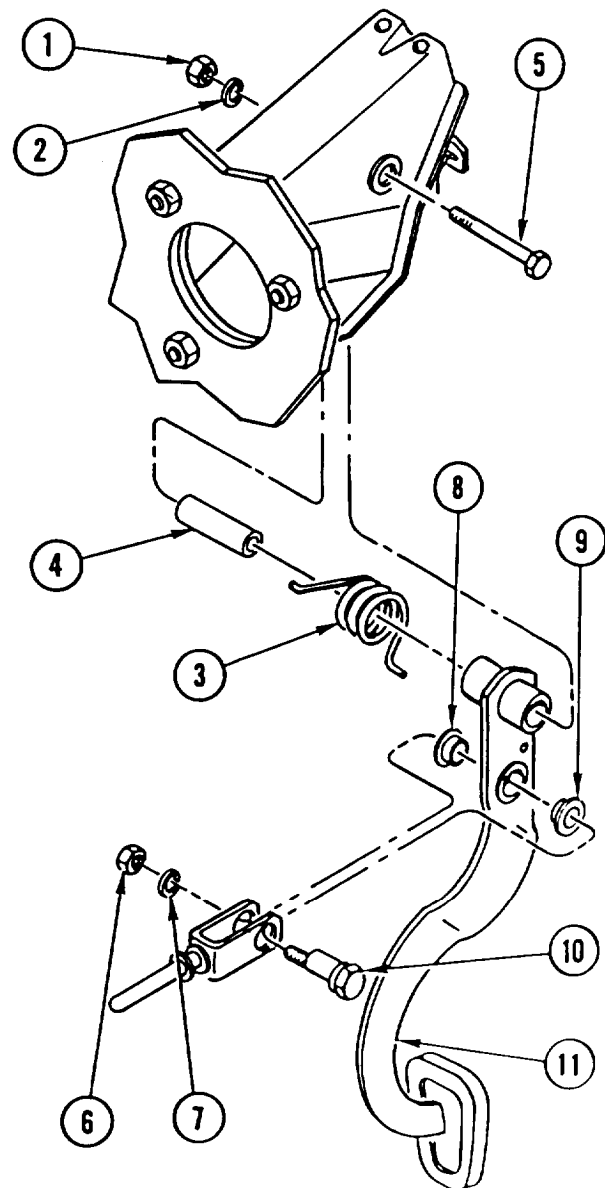

BRAKE PEDAL ADJUSTMENT

This task covers: Adjustment

INITIAL SETUP**Tools and Special Equipment:**

Tool Kit, SC 5180-90-CL-N26

ADJUSTMENT

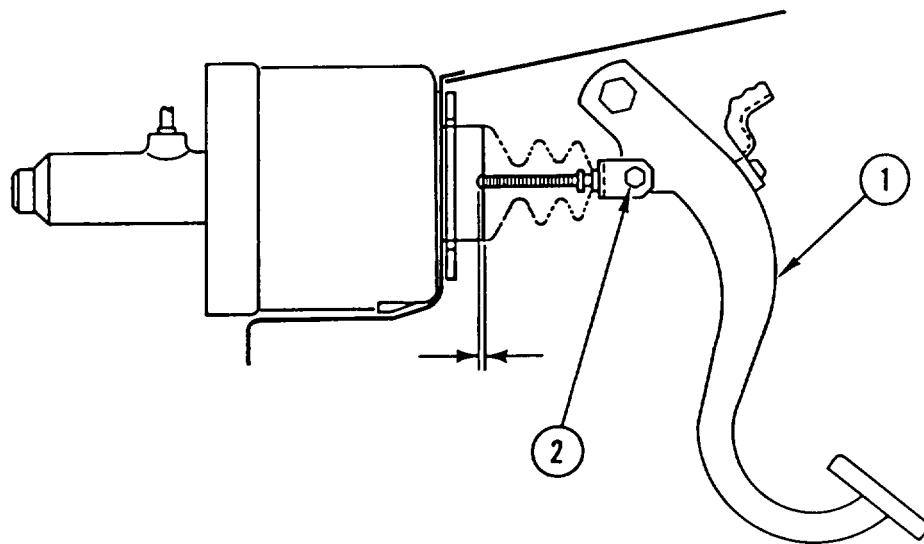

1. With brake pedal (1) at neutral, piston rod clearance must be 0.04 in. (1 mm).
2. If measurement is not within tolerance, adjust clearance by turning eccentric screw (2).

AIR PRESSURE TANKS REPLACEMENT

This task covers: a. Removal b. Installation

INITIAL SETUP

Tools and Special Equipment:

Shop Equipment, SC 4910-95-CL-A74
Tool Kit, SC 5180-90-CL-N26

Materials/Parts:

Seal (2)
Packing (4)
Packing (2)

Personnel Required: (2)

References:

TM 5-2420-224-10

Equipment Condition:

Reference	Condition Description
Page 2-23	Air Pressure Relieved

General Safety Instructions:

WARNING

- Do not disconnect any air system lines or fittings unless vehicle engine is shut off and air system pressure is relieved. To do so could result in injury to personnel.
- Large air pressure tank weighs 30 pounds (14 kilograms) and small air pressure tank weighs 25 pounds (12 kilograms). To avoid personal injury, use a hoist or suitable lifting device when lifting air pressure tank.

REMOVAL

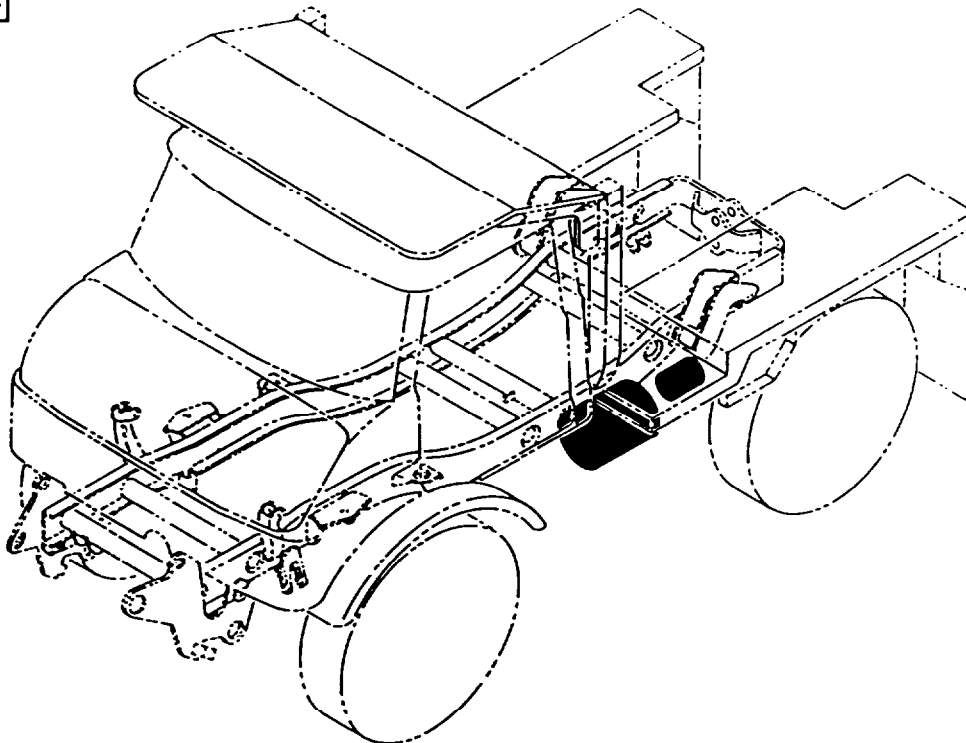

AIR PRESSURE TANKS REPLACEMENT (CONT)

NOTE

- Perform steps 1 thru 9 to remove large air pressure tank.
- Perform steps 10 thru 18 to remove small air pressure tank.
- Tag all lines prior to disconnecting to aid in connecting.

1. DISCONNECT two LINES (1 and 2).

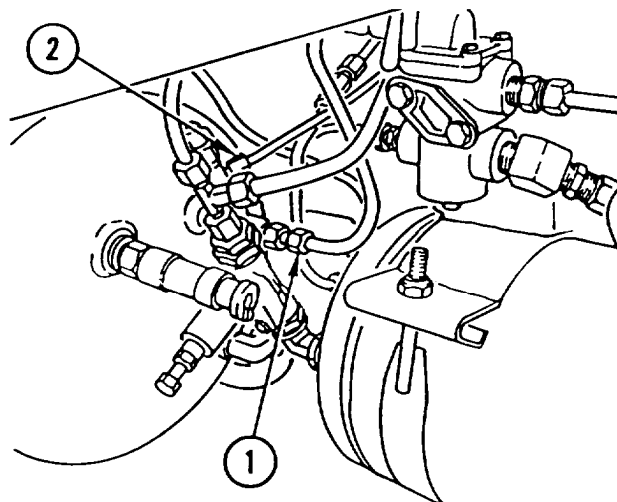

2. DISCONNECT HOSE (3).

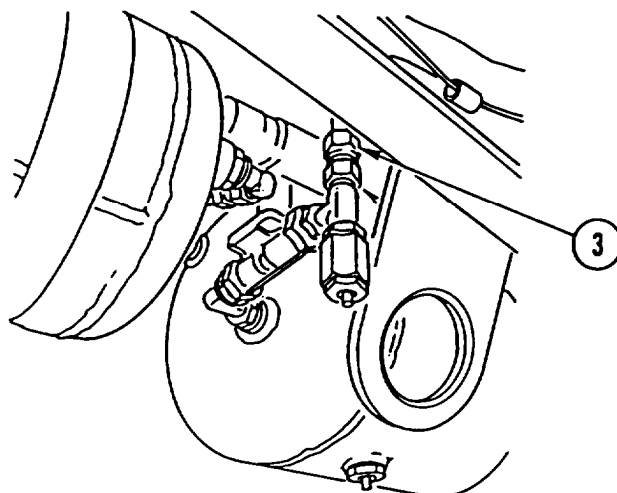

WARNING

Clamp may spring open when bolt is removed. Wear safety goggles when removing and installing clamps. Failure to do so could result in injury to personnel.

3. REMOVE two bolts (4 and 5), two clamps (6 and 7), and large air' pressure TANK (8).

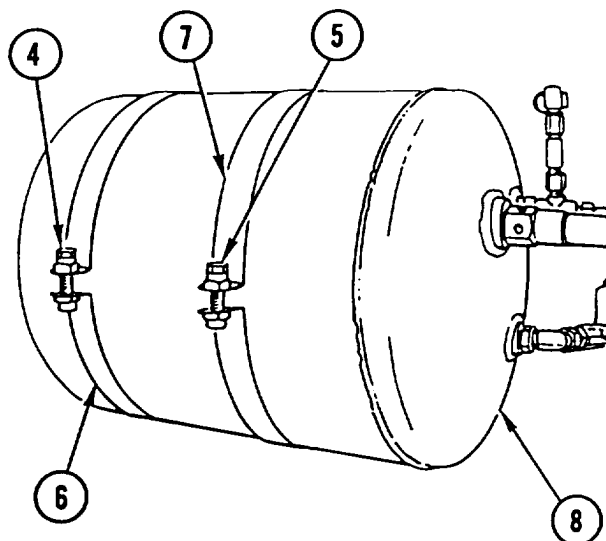

AIR PRESSURE TANKS REPLACEMENT (CONT)

- REMOVE cap (9), relief VALVE (10), and seal (11). DISCARD SEAL.

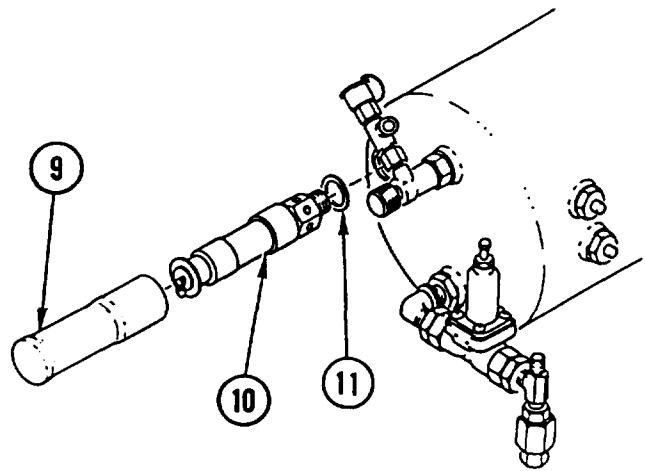

- LOOSEN NUT (12),

NOTE

Note position of assembled valve prior to removal to aid in installation.

- REMOVE assembled VALVE and fitting (13), packing (14), and retainer (15). DISCARD PACKING.

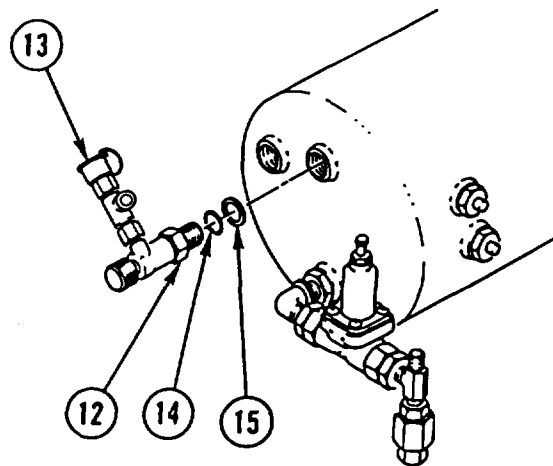

- LOOSEN NUT (16).

NOTE

Note position of assembled valve prior to removal to aid in installation.

- REMOVE assembled VALVE (17), packing (18), and retainer (19). DISCARD PACKING.
- REMOVE draincock VALVE (20), packing (21), and retainer (22). DISCARD PACKING.

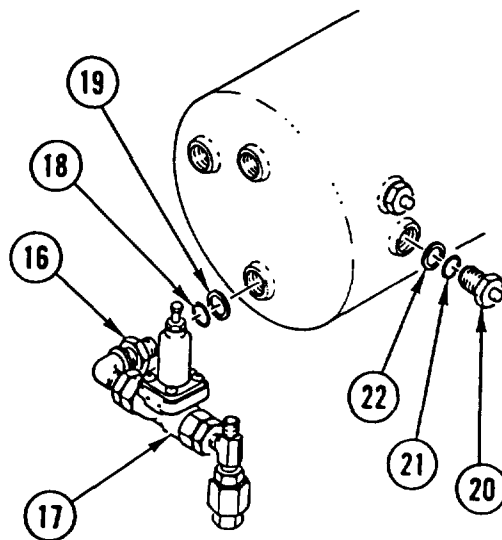

AIR PRESSURE TANKS REPLACEMENT (CONT)

10. REMOVE HOSE (23).
11. DISCONNECT two LINES (24 and 25).

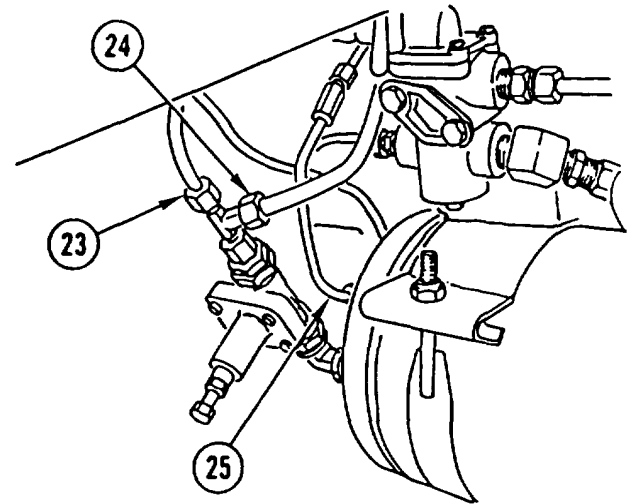

WARNING

Bracket may spring open when nut is removed. Wear safety goggles when removing and installing bracket. Failure to do so could result in injury to personnel.

12. REMOVE nut (26) from bracket (27), and remove small air pressure TANK (28).
13. REMOVE cap (29), relief VALVE (30), and seal (31) from small air pressure tank (28). DISCARD SEAL.
14. LOOSEN NUT (32).

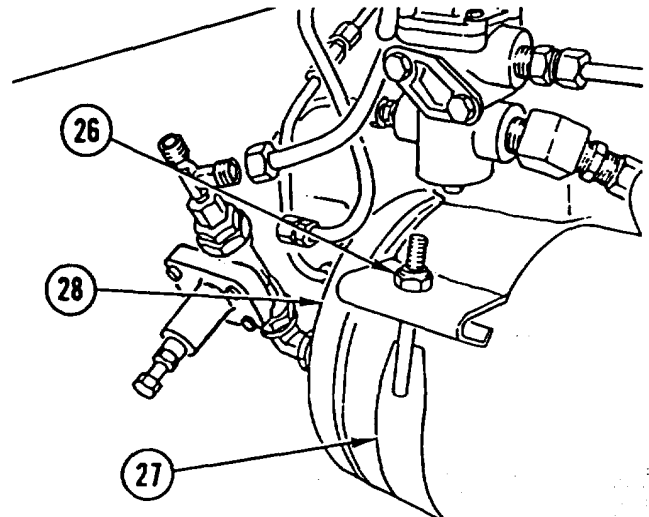

NOTE

Note position of elbow prior to removal to aid in installation.

15. REMOVE ELBOW (33), packing (34), and retainer (35). DISCARD PACKING.
16. LOOSEN NUT (36).

NOTE

Note position of assembled valve prior to removal to aid in installation.

17. REMOVE assembled VALVE and elbow (37), packing (38), and retainer (39). DISCARD PACKING.
18. REMOVE draincock VALVE (40), packing (41), and retainer (42). DISCARD PACKING.

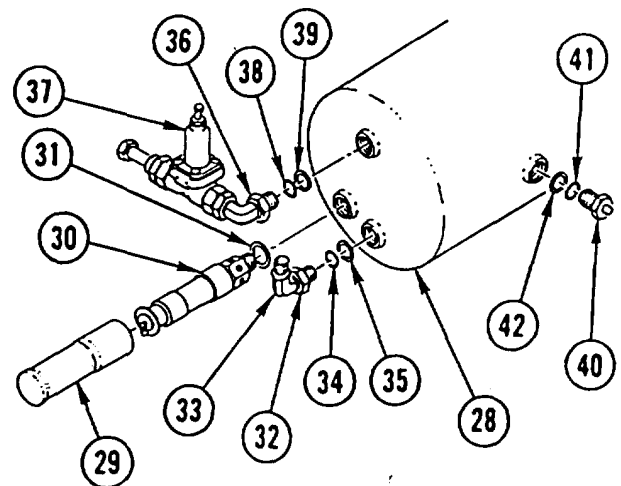

AIR PRESSURE TANKS REPLACEMENT (CONT)

INSTALLATION

NOTE

- Perform steps 1 thru 7 to install large air pressure tank.
- Perform steps 8 thru 14 to install small air pressure tank.

1. INSTALL draincock VALVE (1), new packing (2), and retainer (3).
2. INSTALL assembled VALVE and elbow (4) in position noted during Removal, new packing (5), and retainer (6).
3. INSTALL ELBOW (7) in position noted during Removal, new packing (8), and retainer (9) on small air pressure tank (10).
4. INSTALL relief VALVE (11), new seal (12), and cap (13).

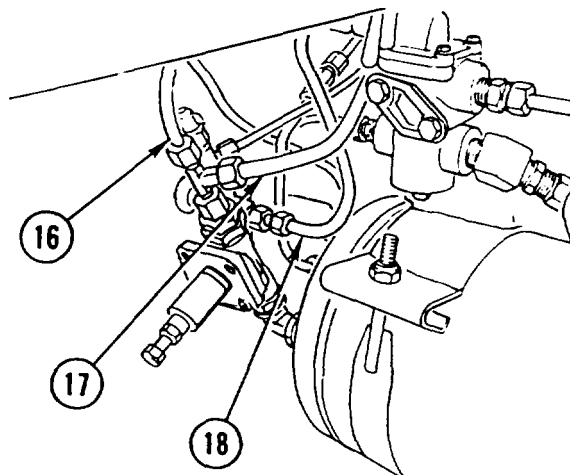
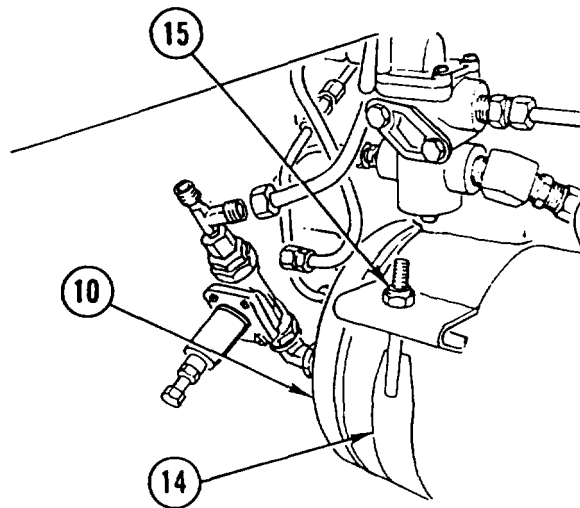
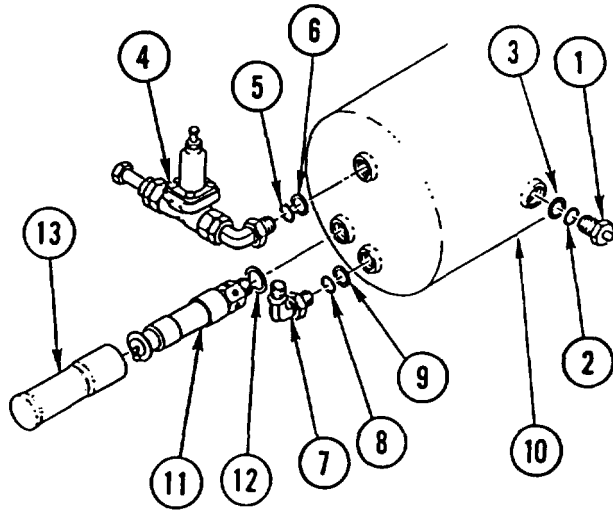

5. INSTALL small air pressure TANK (10), bracket (14), and nut (15).
6. INSTALL HOSE (16).
7. CONNECT two LINES (17 and 18).

WARNING

Wear safety goggles when installing and tightening nut on bracket. Failure to do so could result in injury to personnel.

AIR PRESSURE TANKS REPLACEMENT (CONT)

8. INSTALL assembled VALVE (19) in position noted during Removal, new packing (20), and retainer (21) on large air pressure tank (22),
9. INSTALL draincock VALVE (23), new packing (24), and retainer (25).

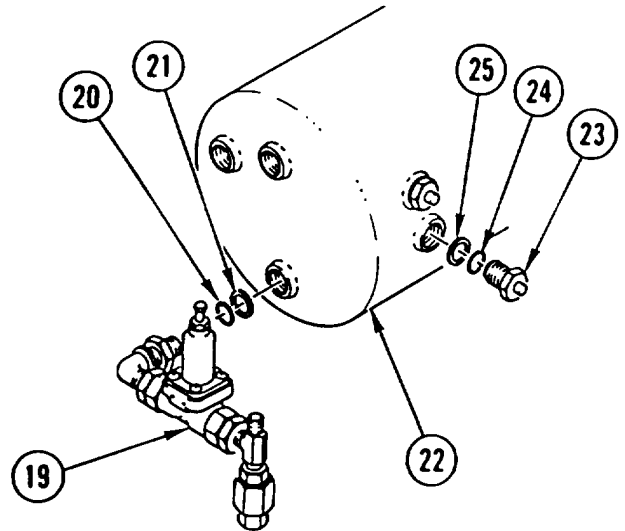

10. INSTALL assembled VALVE and fitting (26) in position noted during Removal, new packing (27), and retainer (28).

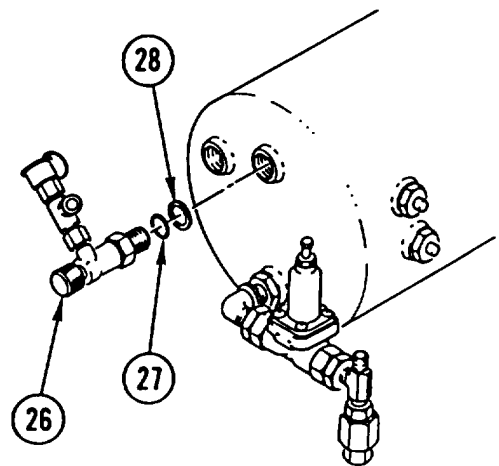

11. INSTALL relief VALVE (29), new seal (30), and cap (31).

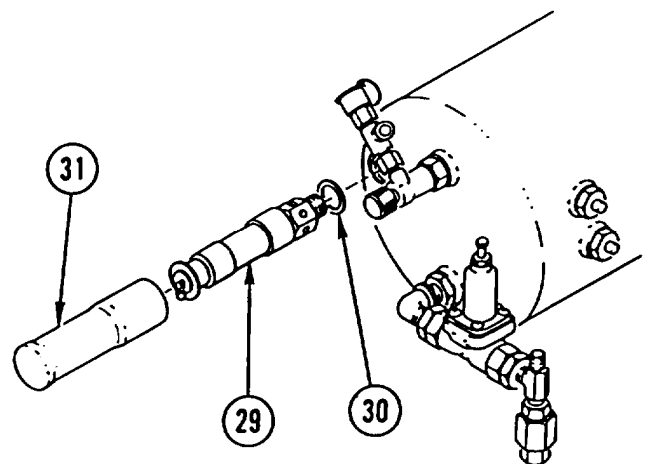

AIR PRESSURE TANKS REPLACEMENT (CONT)

WARNING
Wear safety goggles when installing and tightening bolts on clamps. Failure to do so could result in injury to personnel.

12. INSTALL large air pressure TANK (22), two clamps (32), and two bolts (33).

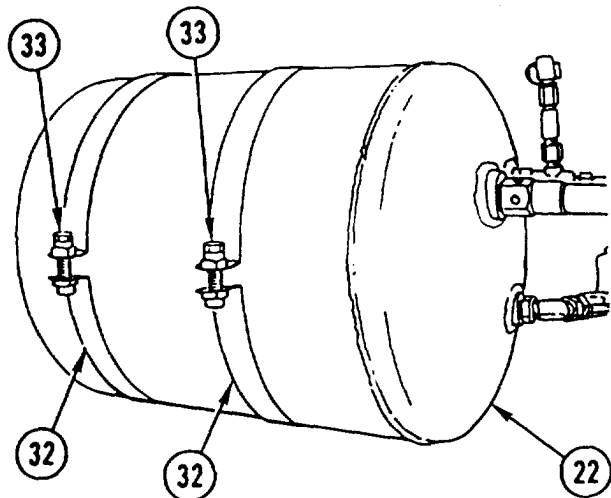

13. CONNECT HOSE (34).

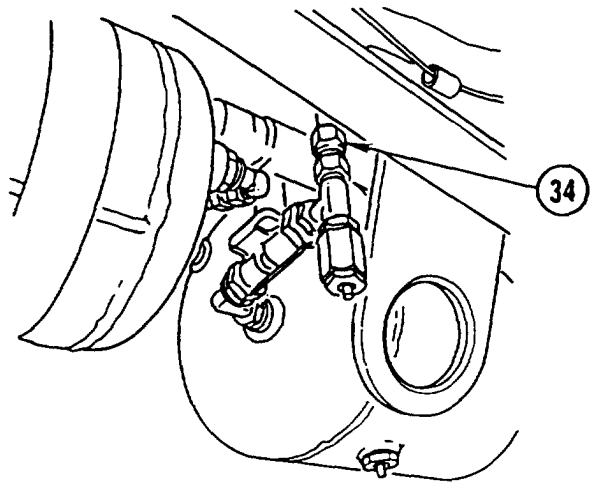

14. CONNECT two LINES (16 and 35).

NOTE

Follow-on Maintenance:
Start engine and check for air leaks (TM 5-2420-224-10).

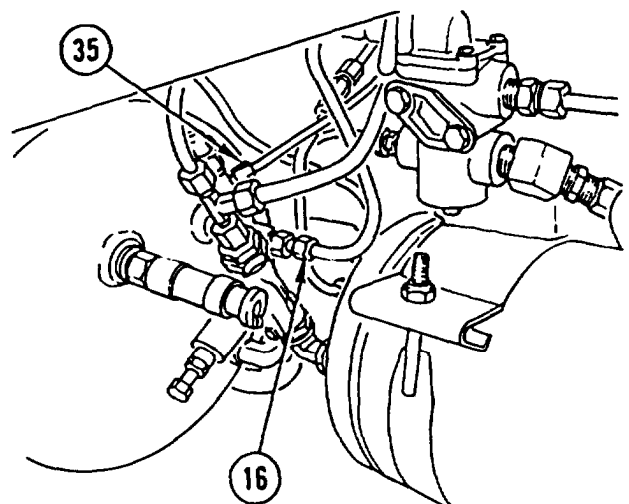

AIR BRAKE BOOSTER REPLACEMENT

This task covers: a. Removal b. Installation

INITIAL SETUP

Tools and Special Equipment:

Tool Kit, SC 5180-90-CL-N26

Materials/Parts:

- Ring, Seal (2)
- Ring, Seal (2)
- Ring, Seal (2)
- Ring, Seal (3)
- Washer, Lock
- Washer, Lock (3)

Equipment Condition:

Reference	Condition Description
Page 4-388	Outside Engine Hood Removed
Page 4-276	Brake Master Cylinder Removed
Page 2-23	Air Pressure Relieved

General Safety instructions:

WARNING

Do not disconnect any air system lines or fittings unless vehicle engine is shut off and air system pressure is relieved. To do so could result in injury to personnel.

REMOVAL

NOTE

Tag air lines prior to disconnecting to aid in connecting.

1. REMOVE three fluid passage BOLTS (1) and six seal rings (2). Disconnect LINE (3) and two tubes (4). DISCARD seal RINGS.

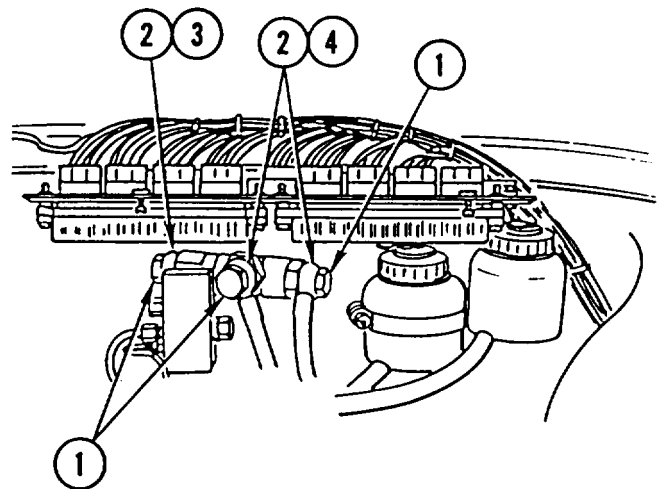

AIR BRAKE BOOSTER REPLACEMENT (CONT)

2. REMOVE fluid passage BOLT (5) and three seal rings (6). DISCARD seal RINGS.
3. DISCONNECT two LINES (7 and 8) and SET two VALVES (9) aside.

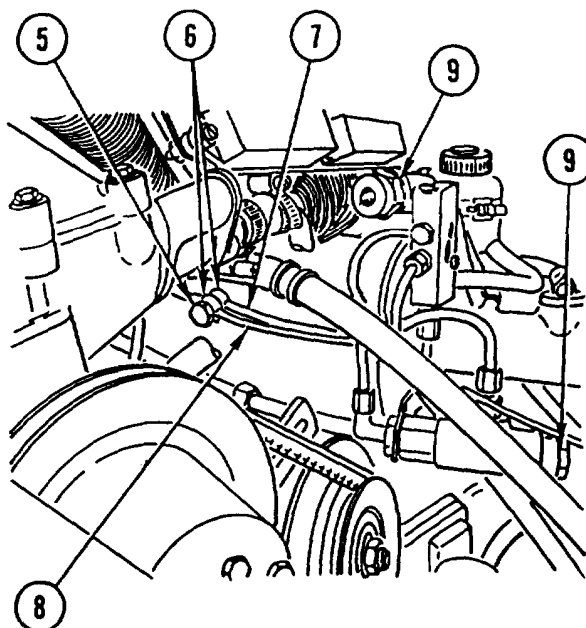

4. REMOVE nut (10), lock washer (11), and eccentric BOLT (12). DISCARD lock WASHER.
5. CAREFULLY ROLL rubber COVER (13) away from brake booster (14) and REMOVE rubber cover (13) and clevis ROD (15).
6. REMOVE three nuts (16), three lock washers (17), and brake BOOSTER (14). DISCARD lock WASHERS.

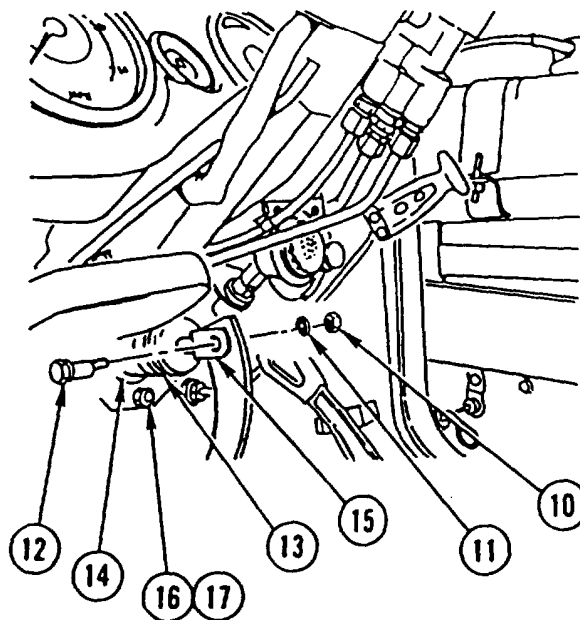

AIR BRAKE BOOSTER REPLACEMENT (CONT)

INSTALLATION

1. INSTALL brake BOOSTER (1), three new lock washers (2), and three nuts (3).
2. INSTALL clevis ROD (4) and rubber cover (5) and CAREFULLY ROLL rubber COVER (5) over brake booster (1).
3. INSTALL eccentric BOLT (6), new lock washer (7), and nut (8).

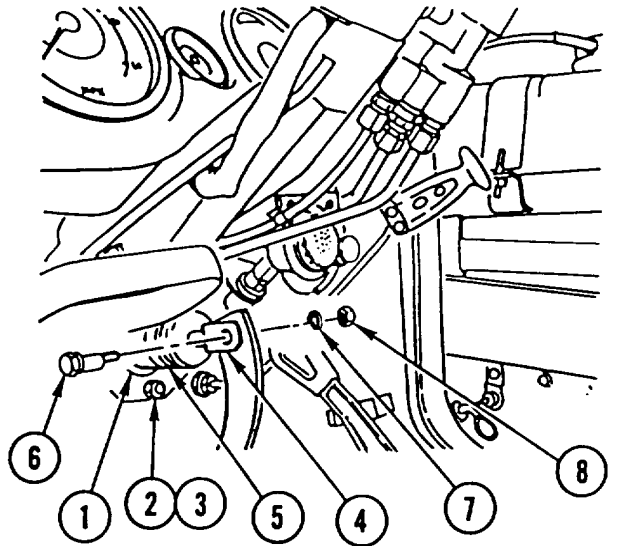

4. POSITION two VALVES (9) and CONNECT two LINES (10 and 11).
5. INSTALL three new seal rings (12) and fluid passage BOLT (13).

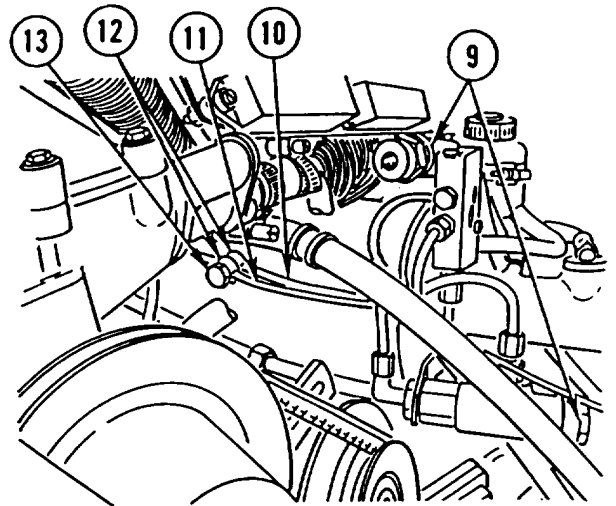

6. CONNECT LINE (14) and two tubes (15). INSTALL six new seal rings (16) and three fluid passage BOLTS (17).

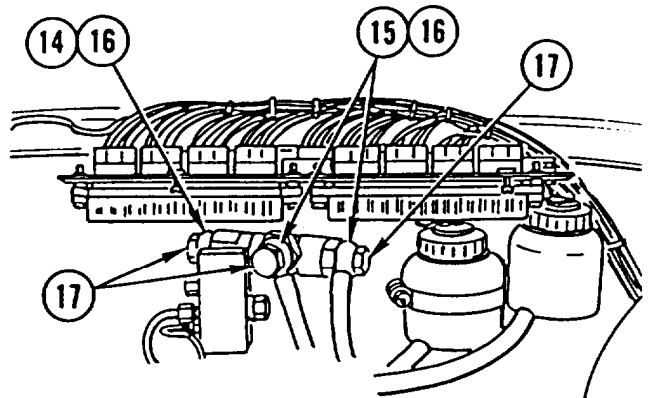

NOTE

Follow-on Maintenance:
 Bleed brake system (page 4-262).
 Adjust brake pedal (page 4-287).
 Install brake master cylinder (page 4-276).
 Install outside engine hood (page 4-388).

ANTIFREEZE RESERVOIR REPLACEMENT

This task covers: a. Removal b. Installation

INITIAL SETUP

Tools and Special Equipment:

Shop Equipment, SC 4910-95-CL-A74
Tool Kit, SC 5180-90-CL-N26
Clamp, P/N 451 42 110

References:

None

General Safety Instructions:

WARNING

Alcohol is extremely flammable. Do not work on antifreeze air system in presence of sparks or open flame. To do so could result in injury to personnel.

Materials/Parts:

Washer, Spring
Tension (2)

Packing (2)

Alcohol

Appendix C, Item 4

REMOVAL

1. DISCONNECT PIPE (1) and DRAIN ALCOHOL into safety container.
2. REMOVE two nuts (2), two spring tension washers (3), bracket (4), antifreeze RESERVOIR (5), and two bolts (6). DISCARD spring tension WASHERS.
3. REMOVE ELBOW (7), adapter (8), retainer (9), and packing (10). DISCARD PACKING.
4. REMOVE nut (11), packing (12), retainer (13), and ADAPTER (14). DISCARD PACKING,
5. REMOVE SLEEVE (15) and nut (16) from pipe (1).

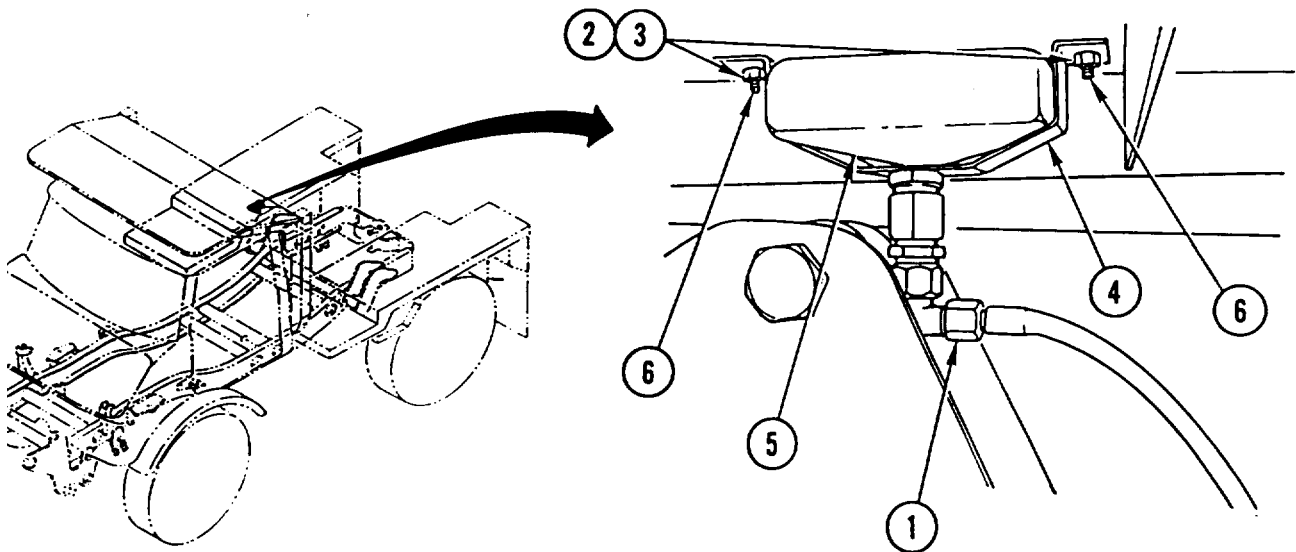

ANTIFREEZE RESERVOIR REPLACEMENT (CONT)

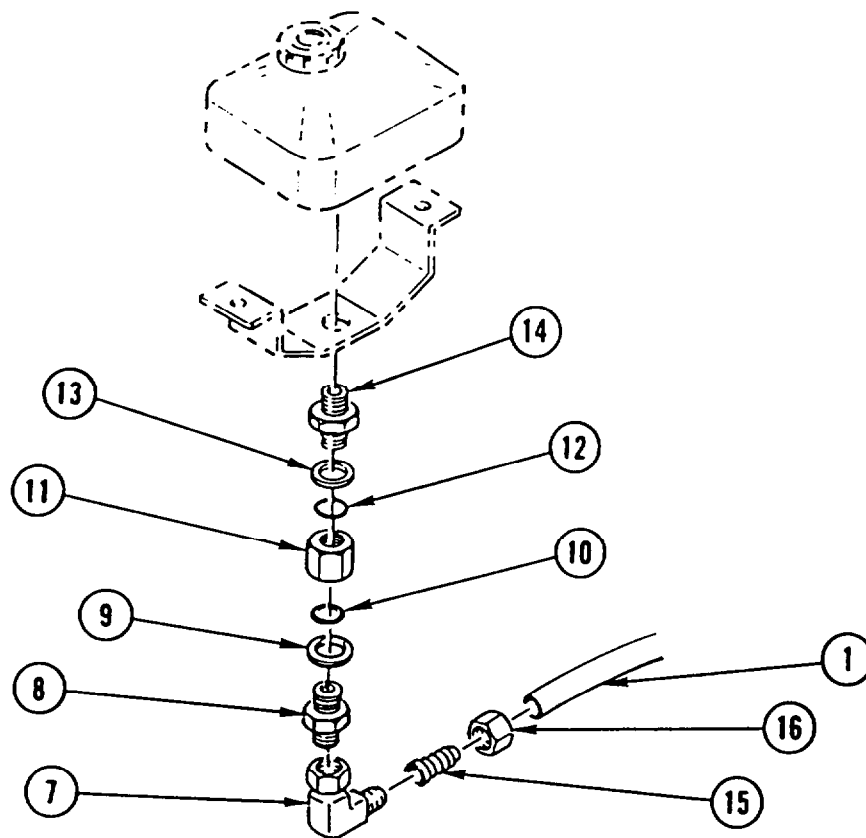

INSTALLATION

1. INSTALL NUT (16) on pipe (1). USING CLAMP, INSTALL SLEEVE (15) in pipe (1).
2. INSTALL ADAPTER (14), retainer (13), new packing (12), and nut (11).
3. INSTALL new packing (10), retainer (9), adapter (8), and ELBOW (7).
4. INSTALL two bolts (6), antifreeze RESERVOIR (5), bracket (4), two new spring tension washers (3), and two nuts (2).
5. CONNECT HOSE (1) and FILL antifreeze RESERVOIR (5) with ALCOHOL (page 2-14).

ANTIFREEZE DEVICE REPLACEMENT

This task covers: a. Removal b. Installation

INITIAL SETUP

Tools and Special Equipment:

Shop Equipment, SC 4910-95-CL-A74
Tool Kit, SC 5180-90-CL-N26
Clamp, P/N 451 42 110

Materials/Parts:

Packing (3)

Alcohol Appendix C, item 4

References:

None

General Safety Instructions:

WARNING

Alcohol is extremely flammable. Do not work on antifreeze air system in presence of sparks or open flame. To do so could result in injury to personnel.

REMOVAL

NOTE

Tag all lines prior to disconnecting to aid in connecting.

1. Disconnect PIPE (1) and DRAIN ALCOHOL into safety container.
2. DISCONNECT air TUBE (2).
3. LOOSEN NUT (3) and Disconnect PUMP (4) from regulator (5).
4. REMOVE nut (6) and PUMP (4).
5. REMOVE ELBOW (7), adapter (8), retainer (9), and packing (10) from pump (4). DISCARD PACKING.
6. REMOVE ELBOW (11), nut (12), retainer (13), and packing (14). DISCARD PACKING.
7. REMOVE ELBOW (15), nut (16), retainer (17), and packing (18). DISCARD PACKING.
8. REMOVE two nuts (19), two screws (20), and BRACKET (21).
9. REMOVE SLEEVE (22) and nut (23) from pipe (1).

ANTIFREEZE DEVICE REPLACEMENT (CONT)

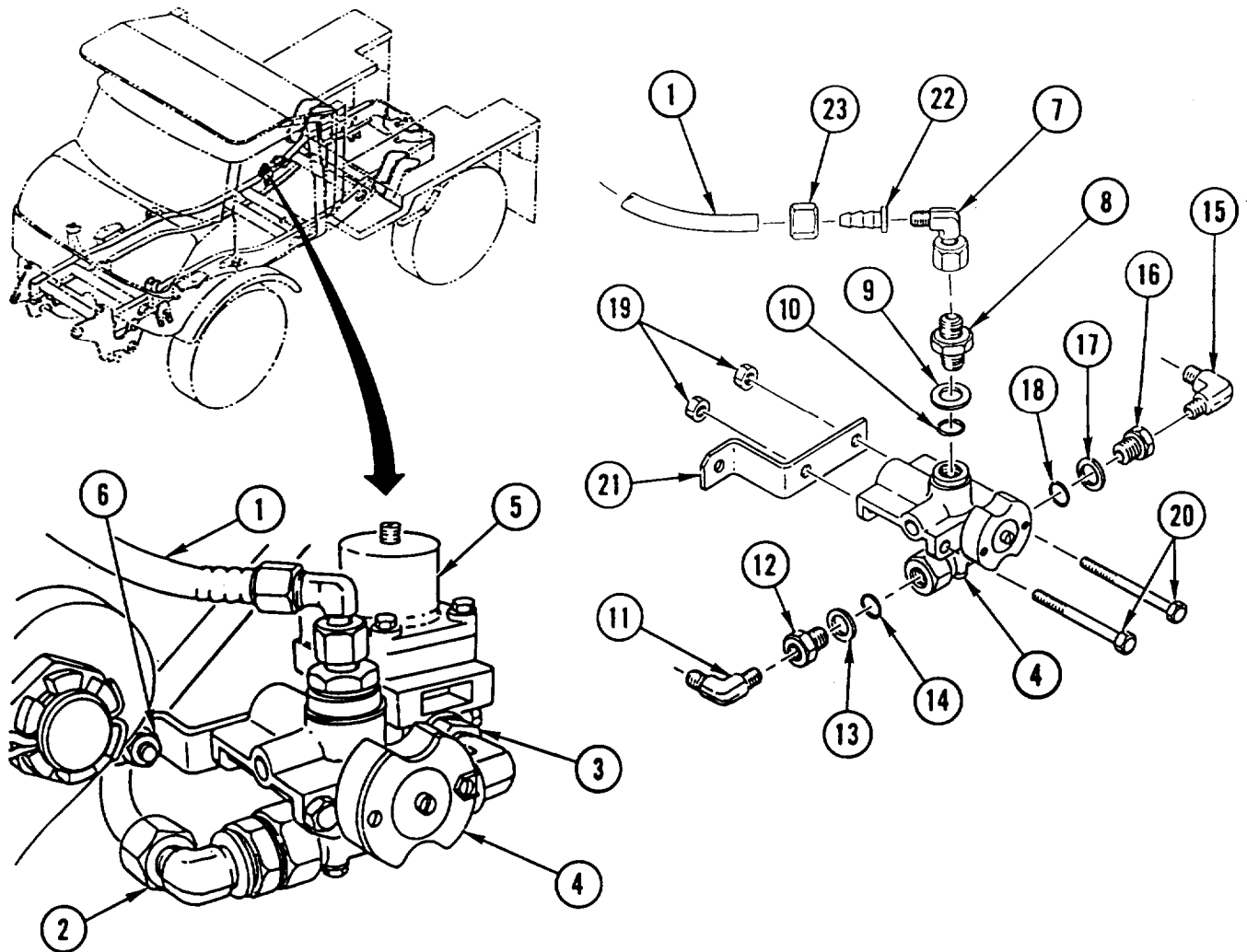

INSTALLATION

1. INSTALL NUT (23). USING CLAMP, INSTALL SLEEVE (22) in pipe (1).
2. INSTALL BRACKET (21), two screws (20), and two nuts (19) on pump (4).
3. INSTALL new packing (18), retainer (17), nut (16), and ELBOW (15).
4. INSTALL new packing (14), retainer (13), nut (12), and ELBOW (11).
5. INSTALL new packing (10), retainer (9), adapter (8), and ELBOW (7).
6. INSTALL PUMP (4) and nut (6).
7. CONNECT pump (4) to regulator (5) and TIGHTEN NUT (3).
8. CONNECT air TUBE (2).
9. CONNECT PIPE (1) and FILL antifreeze RESERVOIR with ALCOHOL (page 2-14).

LARGE AIR PRESSURE TANK OVERFLOW VALVE AND FITTINGS REPLACEMENT

This task covers: a. Removal b. Installation c. Adjustment

INITIAL SETUP

Tools and Special Equipment:

Shop Equipment, SC 4910-95-CL-A74
 Tool Kit, SC 5180-90-CL-N26

Materials/Parts:

Packing
 Preformed (AR)

Equipment Condition:

Reference

Page 4-288

Condition Description

Large Air Pressure Tank
 Removed

REMOVAL

NOTE

Discard packing(s).

REMOVE large air pressure tank overflow VALVE and FITTINGS using illustration and legend as a guide.

INSTALLATION

NOTE

Discard packing(s).

INSTALL large air pressure tank overflow VALVE and FITTINGS using illustration and legend as a guide.

NOTE

Follow-on Maintenance:
 Install large air pressure tank
 (page 4-288).

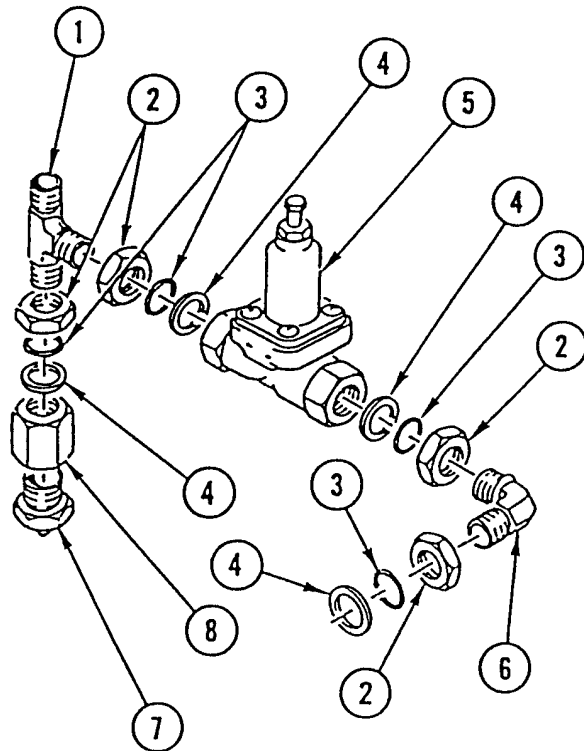

LEGEND

- 1 Tee
- 2 Nut (4)
- 3 Packing (4)
- 4 Retainer (4)
- 5 Valve
- 6 Elbow
- 7 Draincock
- 8 Adapter

LARGE AIR PRESSURE TANK OVERFLOW VALVE AND FITTINGS REPLACEMENT (CONT)

ADJUSTMENT

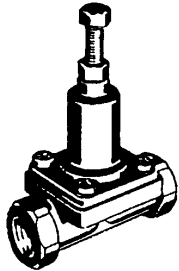

NOTE

This adjustment pertains to the large and small air pressure tank valves, and accessory overflow valve. Refer to the technical data below for proper settings.

Technical Data

Operating pressure	145 psi/10 bar
Overflow pressure accessory valve	80 psi/5.5 bar
Overflow pressure large and small tank valves	75 psi/5.2 bar
Connections	M 22 x 1.5

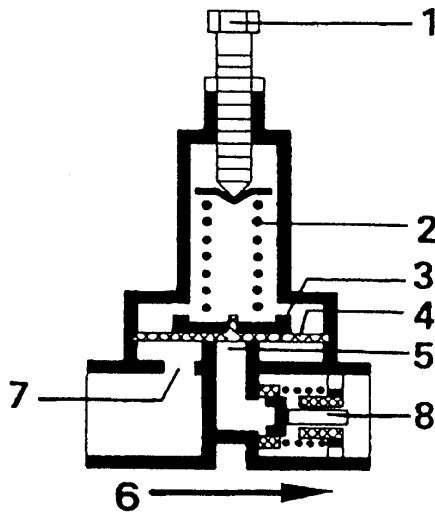

NOTE

Observe direction of arrow for installation of accessory overflow valve.

The overflow pressure can be corrected by turning the adjusting screw (1). To increase overflow pressure, turn adjusting screw in clockwise direction.

- 1 Adjusting screw
- 2 Adjusting spring
- 3 Piston
- 4 Diaphragm
- 5 Overflow channel
- 6 Direction of flow
- 7 Inlet hole
- 8 Check valve (only on accessory overflow valve)

SMALL AIR PRESSURE TANK OVERFLOW VALVE AND FITTINGS REPLACEMENT

This task covers: a. Removal b. Installation c. Adjustment

INITIAL SETUP

Tools and Special Equipment:

Shop Equipment, SC 4910-95-CL-A74
 Tool Kit, SC 5180-90-CL-N26

Materials/Parts:

Packing
 Preformed (AR)

Equipment Condition:

Reference

Page 4-288

Condition Description

Small Air Pressure Tank
 Removed

REMOVAL

NOTE

Discard packing(s).

REMOVE small air pressure tank overflow VALVE and FITTINGS using illustration and legend as a guide.

INSTALLATION

NOTE

Discard packing(s).

INSTALL small air pressure tank overflow VALVE and FITTINGS using illustration and legend as a guide.

NOTE

Follow-on Maintenance:
 Install small air pressure tank
 (page 4-288).

ADJUSTMENT

Adjust and measure small overflow valve pressure (page 4-302.1).

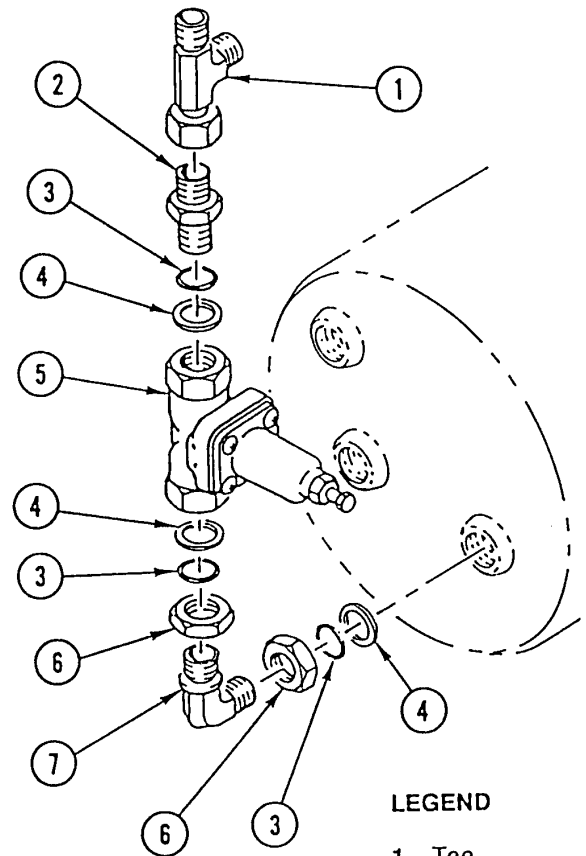

LEGEND

- 1 Tee
- 2 Adapter
- 3 Packing (3)
- 4 Retainer (3)
- 5 Valve
- 6 Nut (2)
- 7 Elbow

ACCESSORY AIR SUPPLY OVERFLOW VALVE AND FITTINGS REPLACEMENT

This task covers: a. Removal b. Installation c. Adjustment

INITIAL SETUP

Tools and Special Equipment:

Shop Equipment, SC 4910-95-CL-A74
 Tool Kit, SC 5180-90-CL-N26

Materials/Parts:

Seal
 Seal (2)
 Packing (2)
 Packing
 Retainer (2)

Equipment Condition:

Reference	Condition Description
Page 2-23	Air Pressure Relieved

General Safety Instructions:

WARNING

Do not disconnect any air system lines or fittings unless vehicle engine is shut off and air system pressure is relieved. To do so could result in injury to personnel.

REMOVAL

NOTE

Tag all lines prior to disconnecting to aid in connecting.

1. DISCONNECT HOSE (1) and LINE (2) from valve assembly (3).
2. REMOVE fluid passage bolt (4), seal (5), TUBE assembly (6), seal (7), TUBE assembly (8), and seal (9) from valve assembly (3). DISCARD SEALS.
3. REMOVE nut (10) and VALVE assembly (3) from frame crossmember (11).
4. REMOVE packing (12), ADAPTER (13), washer (14), reducer (15), packing (16), and retainer (17) from valve assembly (3). DISCARD PACKINGS and RETAINER.
5. REMOVE REDUCER (18), packing (19), and retainer (20) from valve assembly (3). DISCARD PACKING and RETAINER.

ACCESSORY AIR SUPPLY OVERFLOW VALVE AND FITTINGS REPLACEMENT (CONT)

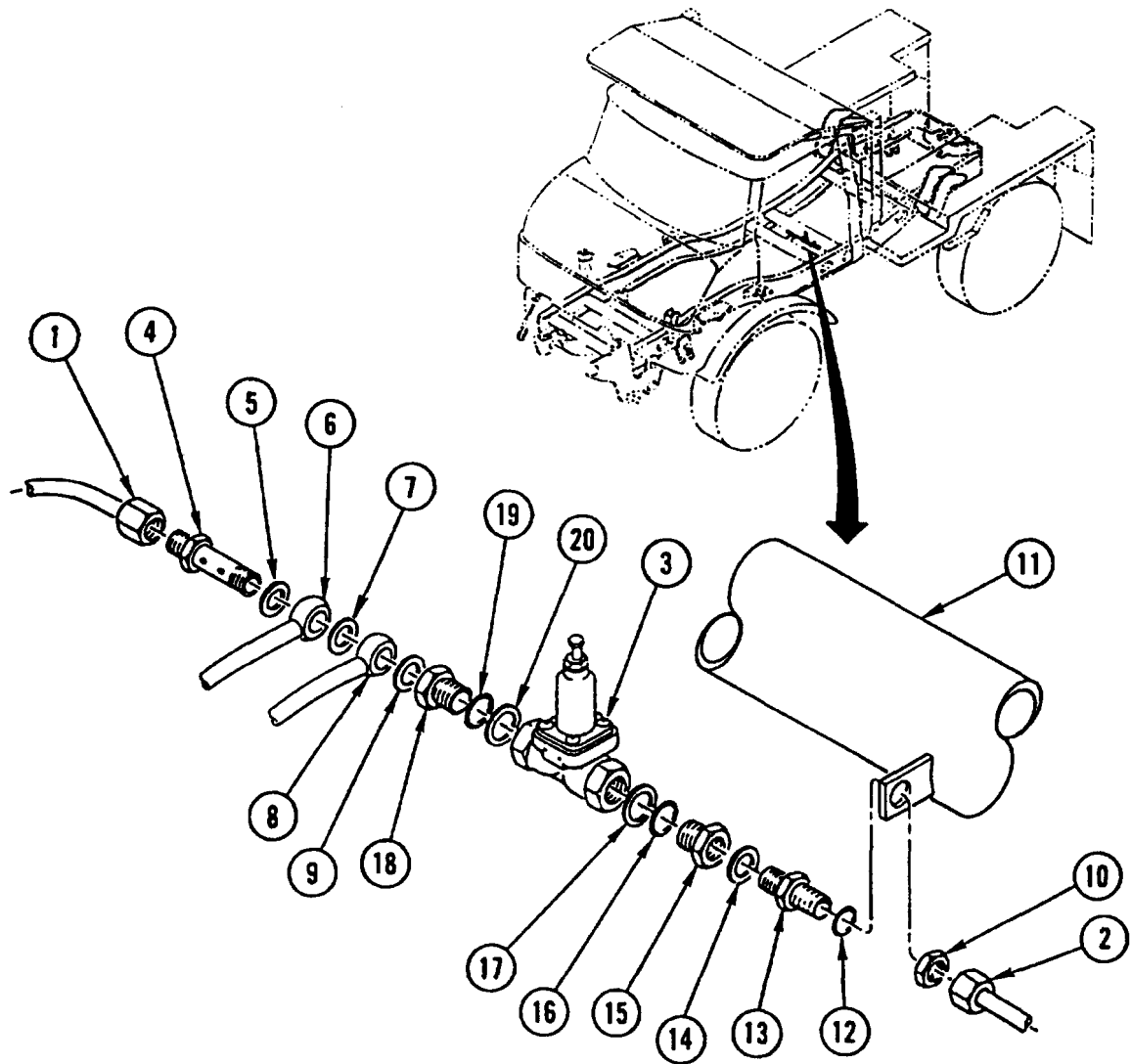

INSTALLATION

1. INSTALL new retainer (20), new packing (19), and REDUCER (18) in valve assembly (3).
2. INSTALL new retainer (17), new packing (16), reducer (15), washer (14), ADAPTER (13), and new packing (12) in valve assembly (3).
3. INSTALL VALVE assembly (3) and nut (10) on frame crossmember (11).
4. INSTALL new seal (9), TUBE assembly (8), new seal (7), TUBE assembly (6), new seal (5), and fluid passage bolt (4) in valve assembly (3).
5. CONNECT LINE (2) and HOSE (1) to valve assembly (3).

ADJUSTMENT

Adjust and measure accessory air supply overflow valve pressure (page 4-302.1).

FLUID REGULATING VALVE REPLACEMENT

This task covers: a. Removal b. Installation

INITIAL SETUP

Tools and Special Equipment:

Shop Equipment, SC 4910-95-CL-A74
 Tool Kit, SC 5180-90-CL-N26

Equipment Condition:

Reference	Condition Description
Page 4-300	Antifreeze Device Removed
Page 2-23	Air Pressure Relieved

General Safety Instructions:

WARNING

Do not disconnect any air system lines or fittings unless vehicle engine is shut off and air system pressure is relieved. To do so could result in injury to personnel.

REMOVAL

1. LOOSEN COUPLING (1).
2. REMOVE fluid regulating VALVE (2) by rotating to left.

INSTALLATION

1. INSTALL fluid regulating VALVE (2) by rotating to right.
2. TIGHTEN COUPLING (1).
3. INSTALL ANTIFREEZE DEVICE (page 4-300).

NOTE

It may be necessary to adjust new regulating valve after installation.

4. Start and run engine at idle until regulating valve reaches cut-out pressure (an audible "pop")
5. Read pressure on dual brake gage. Reading must be approximately 106 psi. If reading is not approximately 106 psi, turn fluid regulating valve adjusting screw (3) 1/4-turn to right to increase pressure, or 1/4-turn to left to decrease pressure. Relieve air pressure (page 2-23) from air tanks to approximately 80 psi and repeat steps 4 and 5 until cut-out pressure is approximately 106 psi.

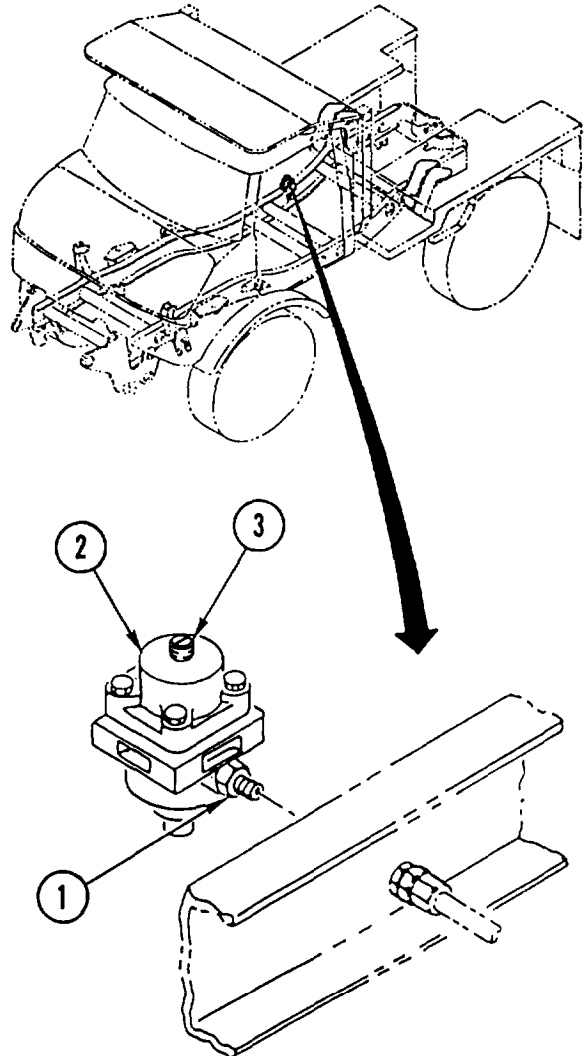

TRAILER SERVICE AIR SUPPLY LINES AND FITTINGS REPLACEMENT

This task covers: a. Removal b. Installation

INITIAL SETUP

Tools and Special Equipment:

Shop Equipment, SC 4910-95-CL-A74
 Tool Kit, SC 5180-90-CL-N26

Materials/Parts:

Seal (AR)
 Nut, Lock (AR)
 Sleeve (AR)

Equipment Condition:

Reference	Condition Description
Page 2-23	Air Pressure Relieved

General Safety Instructions:

WARNING

Do not disconnect any air system lines or fittings unless vehicle engine is shut off and air system pressure is relieved. To do so could result in injury to personnel.

REMOVAL

NOTE

- Tag lines prior to removal to aid in installation.
- Discard seal(s), lock nut(s), and sleeve(s).

REMOVE trailer service air supply LINES and FITTINGS using illustrations and legends (pages 4-308 and 4-309) as a guide.

INSTALLATION

NOTE

Install new seal(s), new lock nut(s), and new sleeve(s).

INSTALL trailer service air supply LINES and FITTINGS using illustrations and legends (pages 4-308 and 4-309) as a guide.

**TRAILER SERVICE AIR SUPPLY LINES AND FITTINGS REPLACEMENT
(CONT)**

LEGEND

- | | |
|----------------------|----------------|
| 1 Fluid passage bolt | 8 Clamp (2) |
| 2 Seal (2) | 9 Tube |
| 3 Adapter | 10 Bracket |
| 4 Pipe | 11 Nut (2) |
| 5 Lock nut (4) | 12 Sleeve (2) |
| 6 Screw (4) | 13 Adapter (2) |
| 7 Bracket | 14 Tube |

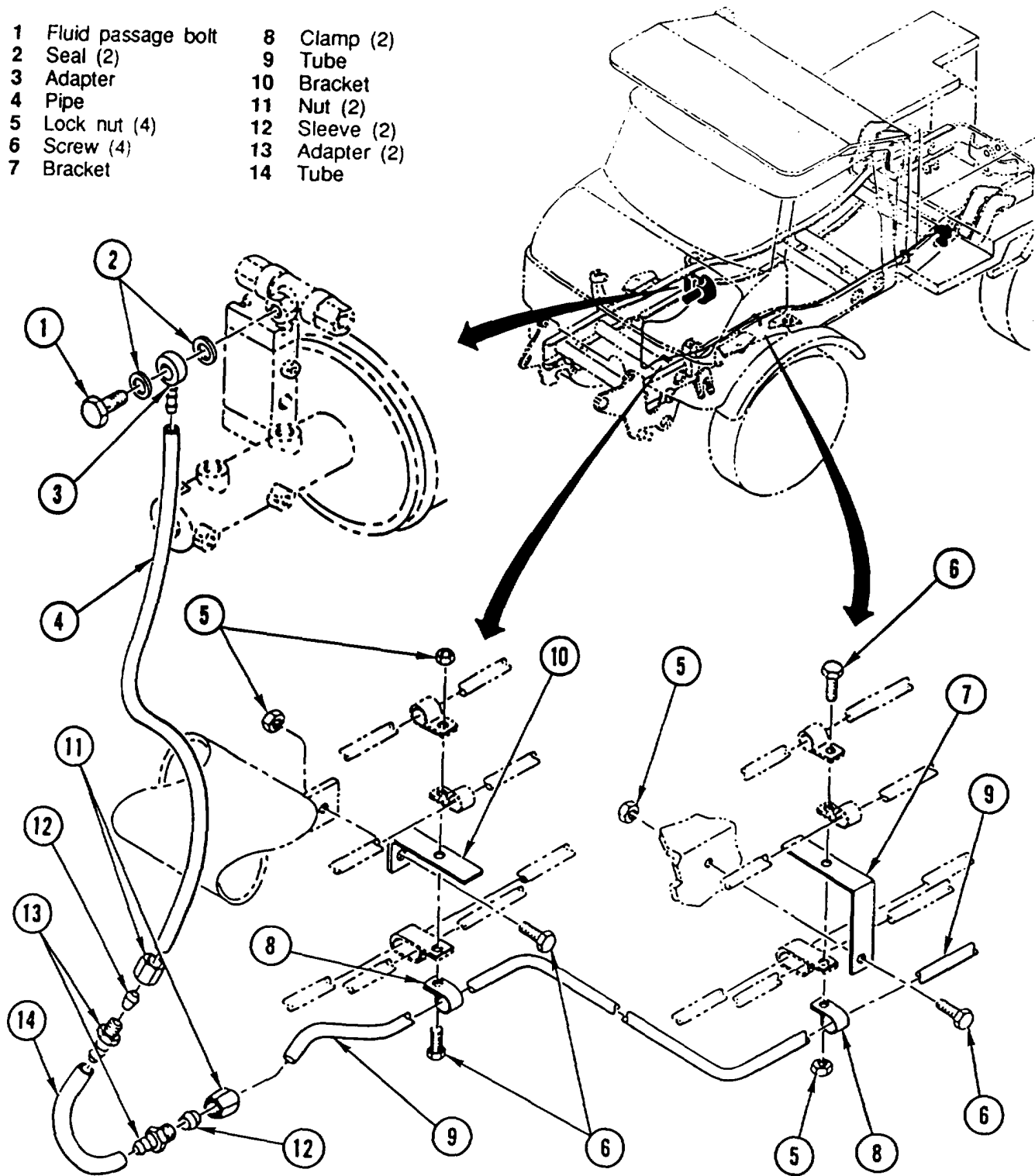

TRAILER SERVICE AIR SUPPLY LINES AND FITTINGS REPLACEMENT
(CONT)

LEGEND

- 1 Lock nut (2)
- 2 Screw (2)
- 3 Bracket
- 4 Nut
- 5 Sleeve
- 6 Pipe union
- 7 Adapter
- 8 Clamp
- 9 Tube

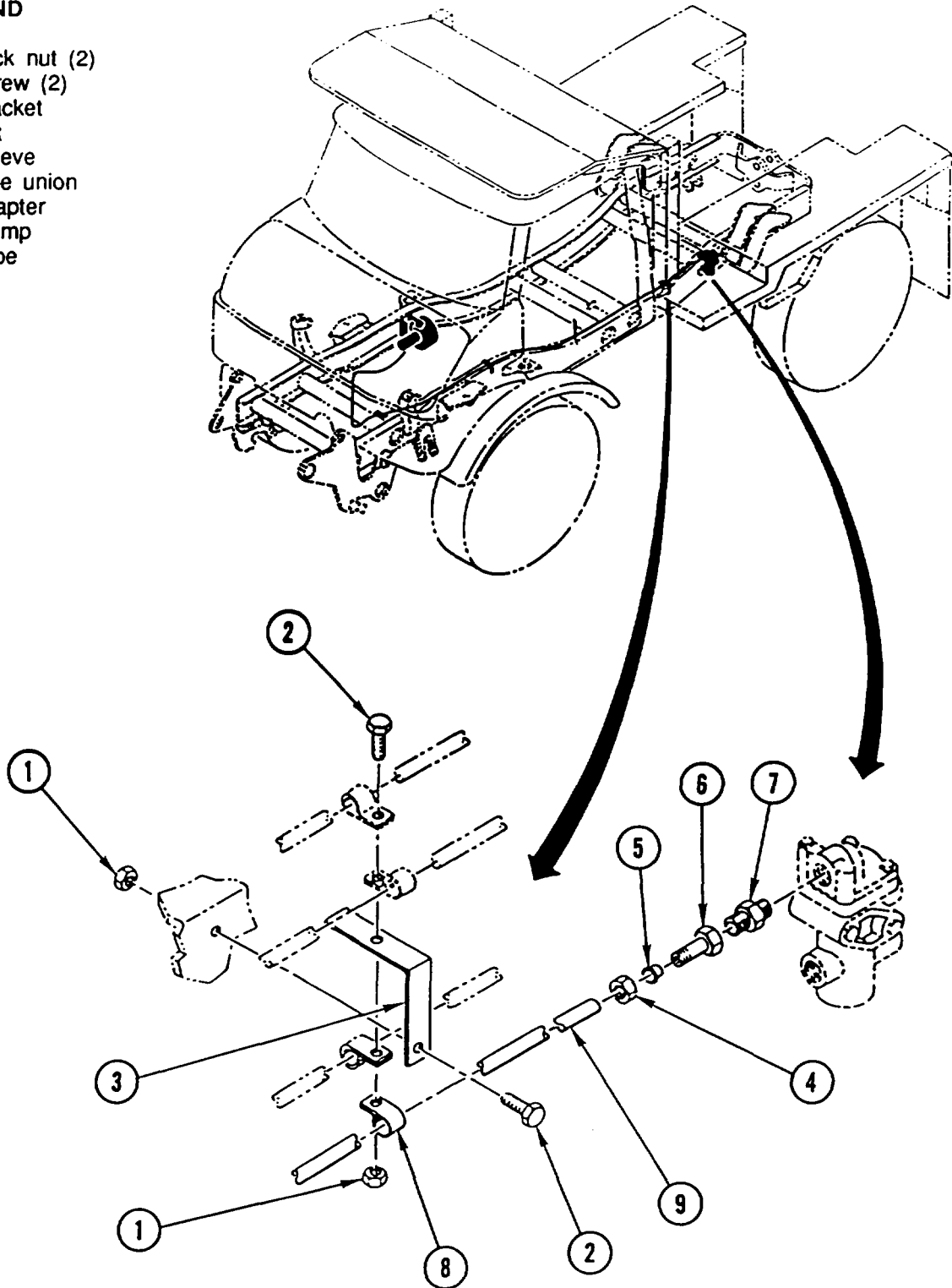

TRAILER EMERGENCY AIR SUPPLY LINES AND FITTINGS REPLACEMENT

This task covers: a. Removal b. installation

INITIAL SETUP

Tools and Special Equipment:

Shop Equipment, SC 4910-95-CL-A74
Tool Kit, SC 5180-90-CL-N26

General Safety Instructions:

WARNING

Do not disconnect any air system lines or fittings unless vehicle engine is shut off and air system pressure is relieved. To do so could result in injury to personnel.

Materials/Parts:

Sleeve (AR)

Nut, Lock (AR)

Equipment Condition:

Reference	Condition Description
Page 2-23	Air Pressure Relieved

REMOVAL

NOTE

- Tag lines prior to removal to aid in installation.
- Discard sleeve(s) and lock nut(s).

REMOVE trailer emergency air supply LINES and FITTINGS using illustrations and legends (pages 4-311 and 4-31 2) as a guide.

INSTALLATION

NOTE

Install new sleeve(s) and new lock nut(s).

INSTALL trailer emergency air supply LINES and FITTINGS using illustrations and legends (pages 4-311 and 4-312) as a guide.

TRAILER EMERGENCY AIR SUPPLY LINES AND FITTINGS
REPLACEMENT (CONT)

LEGEND

- 1 Adapter
- 2 Sleeve
- 3 Nut
- 4 Insert
- 5 Tube
- 6 Lock nut (4)
- 7 Screw (4)
- 8 Clamp
- 9 Bracket
- 10 Clamp
- 11 Bracket
- 12 Tube
- 13 Union (2)
- 14 Sleeve (2)
- 15 Adapter (2)
- 16 Tube

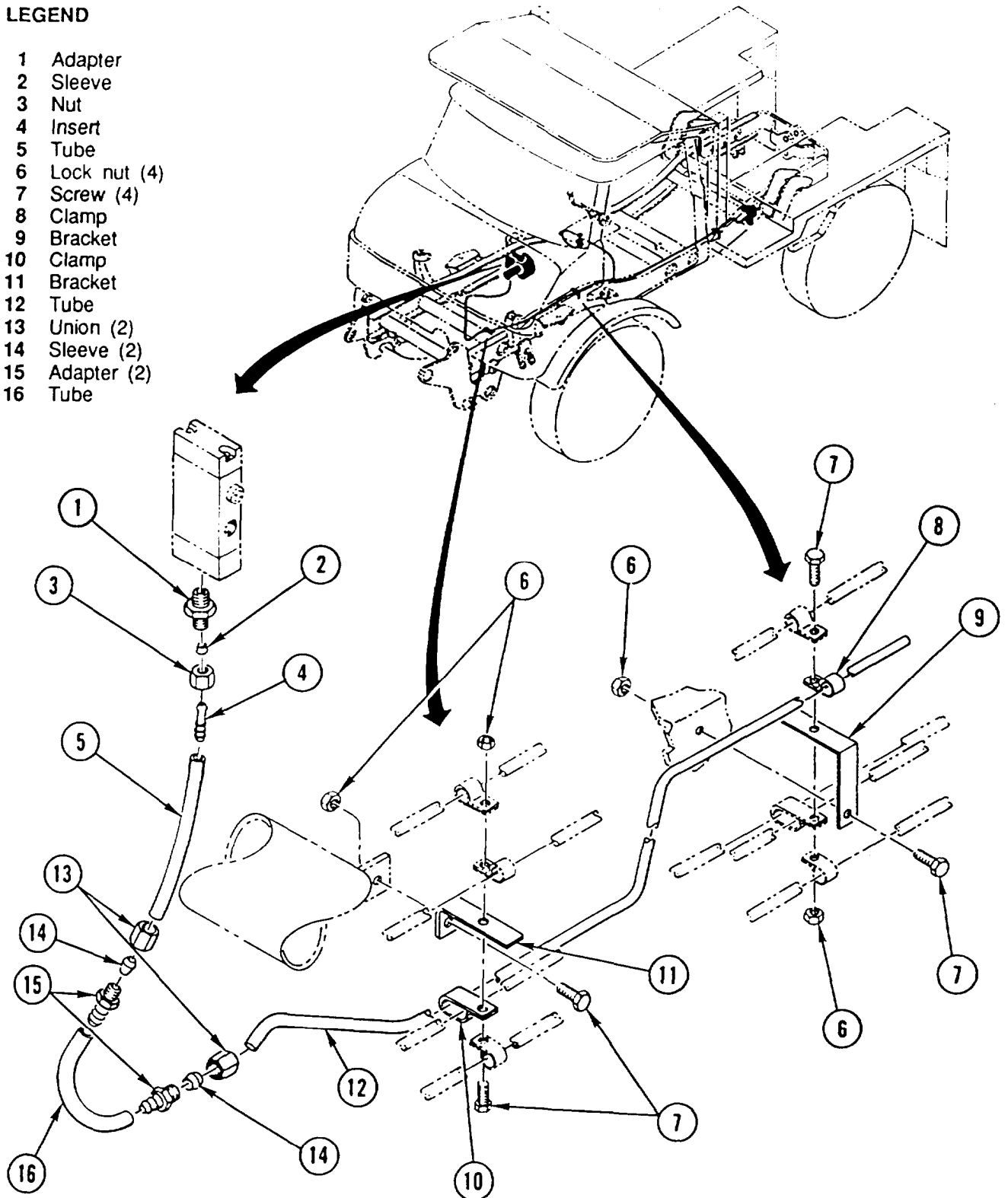

**TRAILER EMERGENCY AIR SUPPLY LINES AND FITTINGS
REPLACEMENT (CONT)**

LEGEND

- 1 Line
- 2 Adapter (2)
- 3 Nut (4)
- 4 Sleeve (5)
- 5 Elbow
- 6 Adapter
- 7 Lock nut (2)
- 8 Screw (2)
- 9 Clamp
- 10 Adapter
- 11 Bracket
- 12 Tee

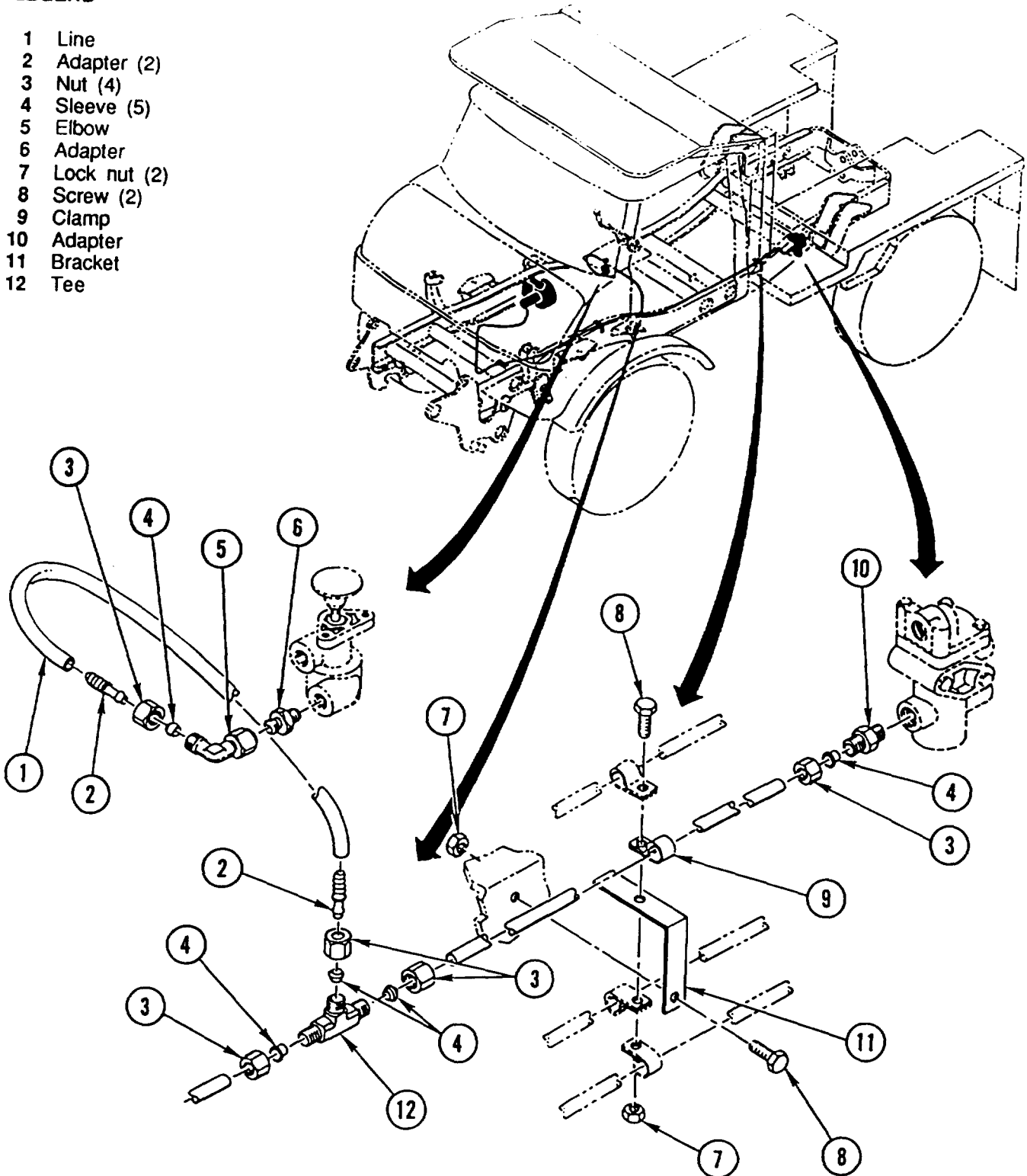

TRAILER AIR SUPPLY VALVE LINES AND FITTINGS REPLACEMENT

This task covers: a. Removal b. Installation

INITIAL SETUP

Tools and Special Equipment:

Shop Equipment, SC 4910-95-CL-A74
 Tool Kit, SC 5180-90-CL-N26

Equipment Condition:

Reference	Condition Description
Page 2-23	Air Pressure Relieved

Materials/Parts:

Sleeve (AR)
 Packing (AR)

General Safety Instructions:

WARNING

Do not disconnect any air system lines or fittings unless vehicle engine is shut off and air system pressure is relieved. To do so could result in injury to personnel.

R E M O V A L

NOTE

- . Tag lines prior to removal to aid in installation.
- . Discard sleeve(s) and packing.

REMOVE trailer air supply valve LINES and FITTINGS using illustration and legend as a guide.

INSTALLATION

NOTE

Install new sleeve(s) and new packing.

INSTALL trailer air supply valve LINES and FITTINGS using illustration and legend as a guide.

**TRAILER AIR SUPPLY VALVE LINES AND FITTINGS REPLACEMENT
(CONT)**

LEGEND

- | | |
|---------------|-------------|
| 1 Tube | 11 Coupling |
| 2 Adapter (2) | 12 Tee |
| 3 Nut (6) | 13 Tube |
| 4 Sleeve (6) | 14 Union |
| 5 Elbow | 15 Elbow |
| 6 Adapter | 16 Nut |
| 7 Tee | 17 Packing |
| 8 Tube | 18 Retainer |
| 9 Clamp | 19 Bracket |
| 10 Screw (2) | 20 Nut |

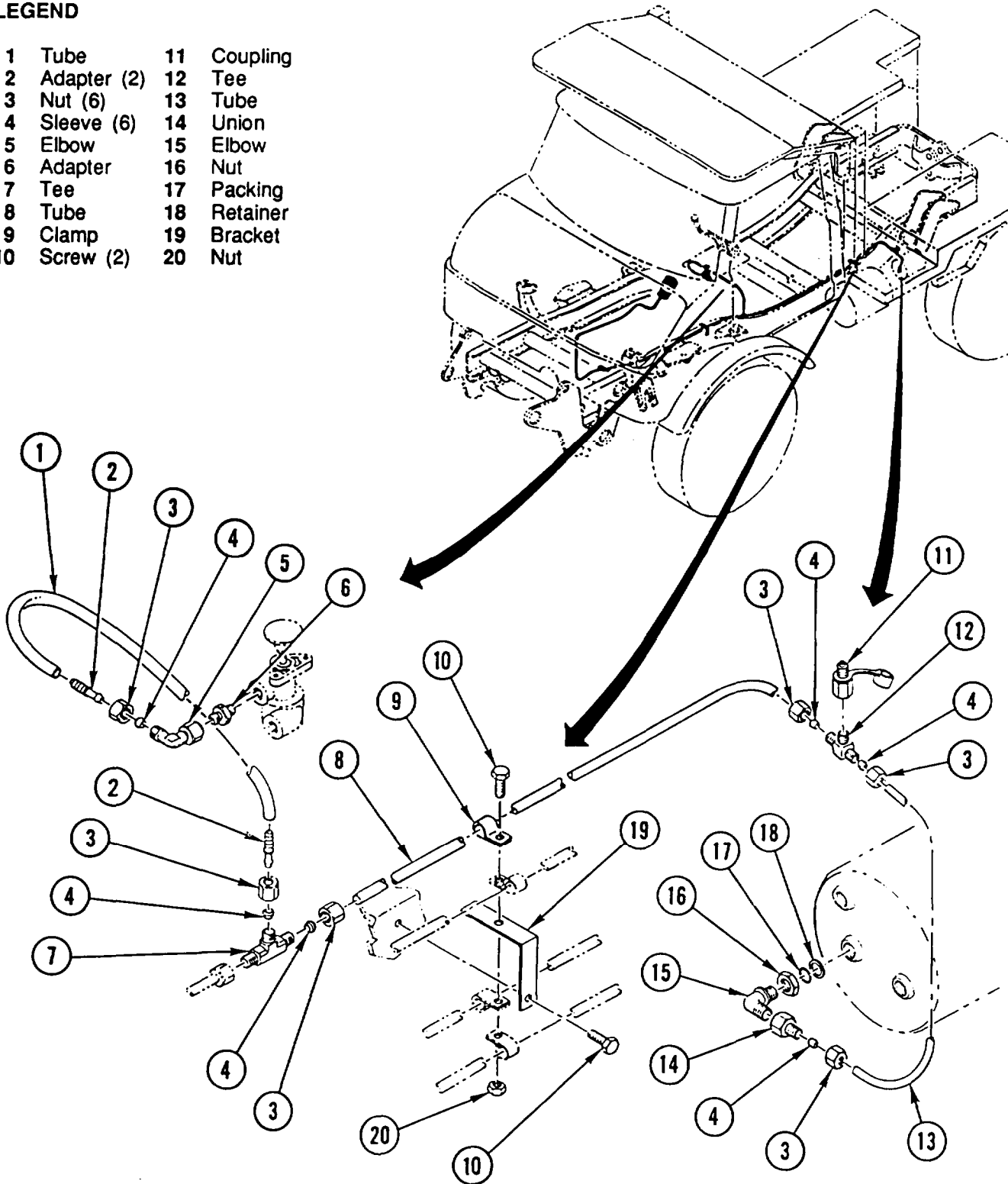

AIR PRESSURE AND ACCESSORY AIR SUPPLY LINES AND FITTINGS REPLACEMENT

This task covers: a. Removal b. Installation

INITIAL SETUP

Tools and Special Equipment:

Shop Equipment, SC 4910-95-CL-A74
 Tool Kit, SC 5180-90-CL-N26

Materials/Parts:

Seal, Ring (AR)
 Nut, Lock (AR)
 Sleeve (AR)
 Packing (AR)

Equipment Condition:

Reference	Condition Description
Page 2-23	Air Pressure Relieved

General Safety Instructions:

WARNING

Do not **disconnect any air** system lines or fittings unless vehicle engine is shut off and air system pressure is relieved. To do so could result in injury to personnel.

REMOVAL

NOTE

- Tag lines prior to removal to aid in installation.
- Discard seal ring(s), lock nut(s), sleeve(s), and packing(s).

REMOVE air pressure and accessory air supply LINES and FITTINGS using illustrations and legends (pages 4-316 and 4-317) as a guide.

INSTALLATION

NOTE

Install new seal ring(s), new lock nut(s), new sleeve(s), and new packing(s).

INSTALL air pressure and accessory air supply LINES and FITTINGS using illustrations and legends (pages 4-316 and 4-317) as a guide.

AIR PRESSURE AND ACCESSORY AIR SUPPLY LINES AND FITTINGS REPLACEMENT (CONT)

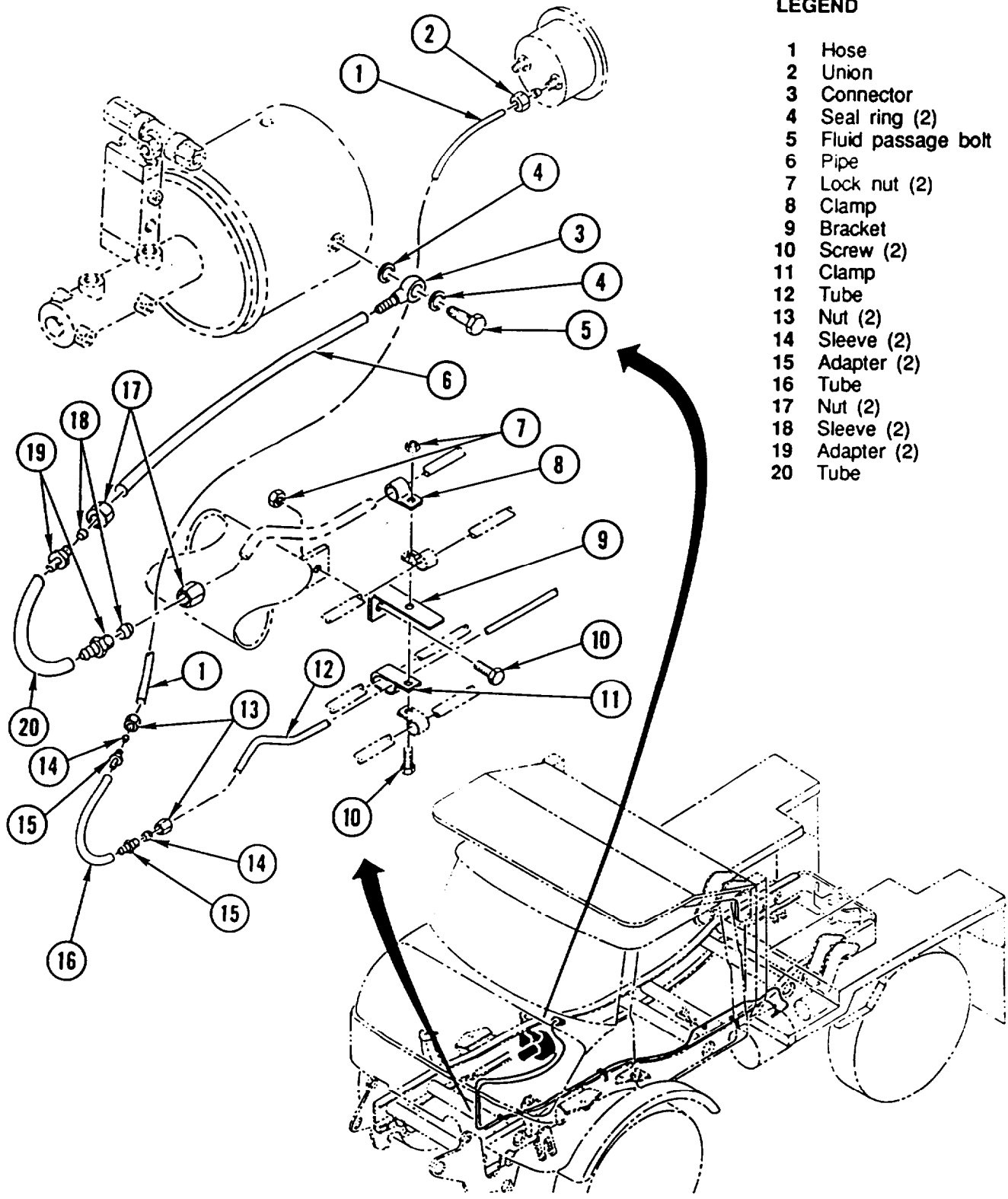

LEGEND

- 1 Hose
- 2 Union
- 3 Connector
- 4 Seal ring (2)
- 5 Fluid passage bolt
- 6 Pipe
- 7 Lock nut (2)
- 8 Clamp
- 9 Bracket
- 10 Screw (2)
- 11 Clamp
- 12 Tube
- 13 Nut (2)
- 14 Sleeve (2)
- 15 Adapter (2)
- 16 Tube
- 17 Nut (2)
- 18 Sleeve (2)
- 19 Adapter (2)
- 20 Tube

AIR PRESSURE AND ACCESSORY AIR SUPPLY LINES AND FITTINGS REPLACEMENT (CONT)

LEGEND

- 1 Nut (6)
- 2 Sleeve (6)
- 3 Tee
- 4 Tube
- 5 Screw (4)
- 6 Tube
- 7 Tee
- 8 Nut
- 9 Packing
- 10 Retainer
- 11 Tee
- 12 Coupling
- 13 Bracket (2)
- 14 Clamp
- 15 Lock nut (2)
- 16 Tube
- 17 Clamp

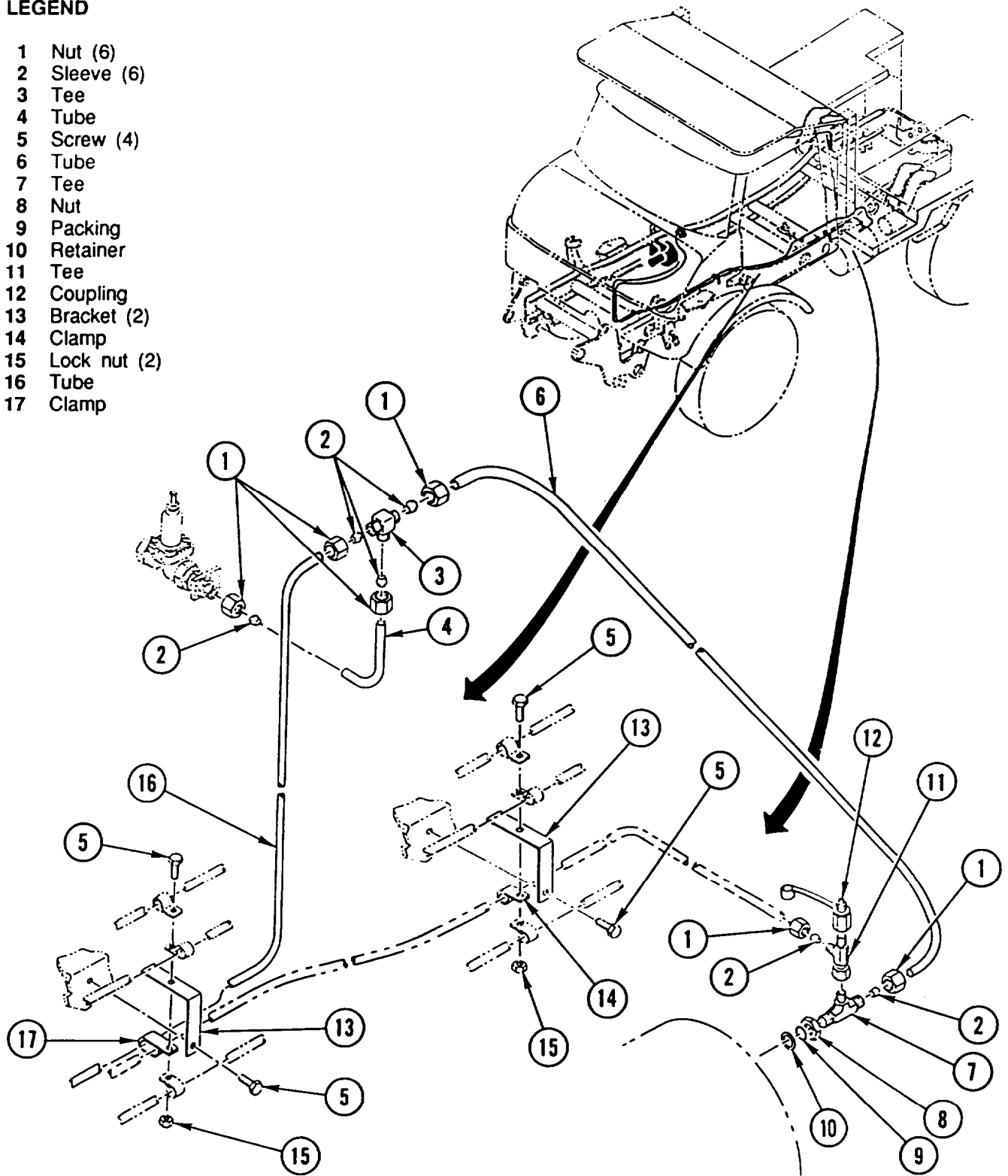

BRAKE BOOSTER AND AIR PRESSURE LINES AND FITTINGS REPLACEMENT

This task covers: a. Removal b. Installation

INITIAL SETUP

Tools and Special Equipment:

Tool Kit, SC 5180-90-CL-N26

Materials/Parts:

Seal (AR)

Seal (AR)

Sleeve (AR)

Packing,
Preformed (AR)

Equipment Condition:

Reference

Page 2-23

Condition Description

Air Pressure Relieved

General Safety Instructions:

WARNING

Do not disconnect any air system lines or fittings unless vehicle engine is shut off and air system pressure is relieved. To do so could result in injury to personnel.

REMOVAL

NOTE

- Tag lines prior to removal to aid in installation.
- Discard seal(s), sleeve(s), and packing(s).

REMOVE brake booster and air pressure LINES and FITTINGS using illustration and legend as a guide.

INSTALLATION

NOTE

Install new seal(s), new sleeve(s), and new packing(s).

INSTALL brake booster and air pressure LINES and FITTINGS using illustration and legend as a guide.

LEGEND

1 Seal (7)	10 Washer (2)
2 Fluid passage bolt (2)	11 Packing (2)
3 Line	12 Nut
4 Seal (2)	13 Elbow
5 Line	14 Nut (2)
6 Hollow screw	15 Line
7 Nut (2)	16 Line
8 Sleeve (4)	17 Fluid passage bolt
9 Adapter	18 Adapter

**BRAKE BOOSTER AND AIR PRESSURE LINES AND FITTINGS
REPLACEMENT (CONT)**

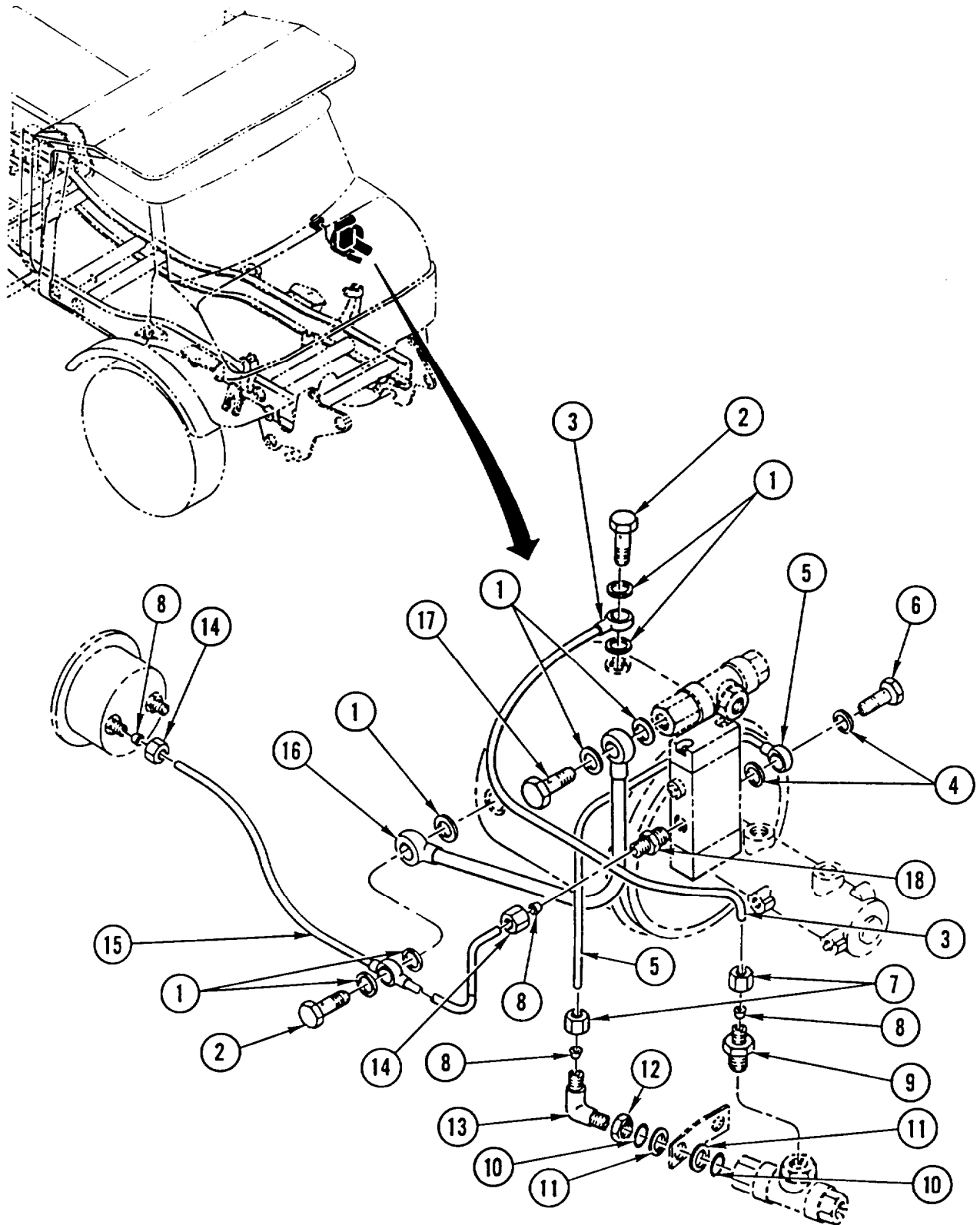

PROTECTION/RELAY VALVE LINES AND FITTINGS REPLACEMENT

This task covers: a. Removal b. Installation

INITIAL SETUP

Tools and Special Equipment:

Tool Kit, SC 5180-90-CL-N26

Materials/Parts:

Sleeve (AR)

Ring, Seal (AR)

Sleeve (AR)

Equipment Condition:

Reference

Page 2-23

Condition Description

Air Pressure Relieved

General Safety Instructions:

WARNING

Do not disconnect any air system lines or fittings unless vehicle engine is shut off and air system pressure is relieved. To do so could result in injury to personnel.

REMOVAL

NOTE

- Tag lines prior to removal to aid in installation.
- Discard sleeve(s) and seal ring(s).

REMOVE protection/relay valve LINES and FITTINGS using illustration and legend as a guide.

INSTALLATION

NOTE

Install new sleeve(s) and new seal ring(s).

INSTALL protection/relay valve LINES and FITTINGS using illustration and legend as a guide.

LEGEND

- | | | |
|--------------|----------------------|------------|
| 1 Tube (2) | 6 Seal ring (2) | 11 Nut |
| 2 Insert (4) | 7 Connector | 12 Sleeve |
| 3 Nut (4) | 8 Fluid passage bott | 13 Adapter |
| 4 Sleeve (4) | 9 Tube | |
| 5 Elbow (2) | 10 Insert | |

PROTECTION/RELAY VALVE LINES AND FITTINGS REPLACEMENT (CONT)

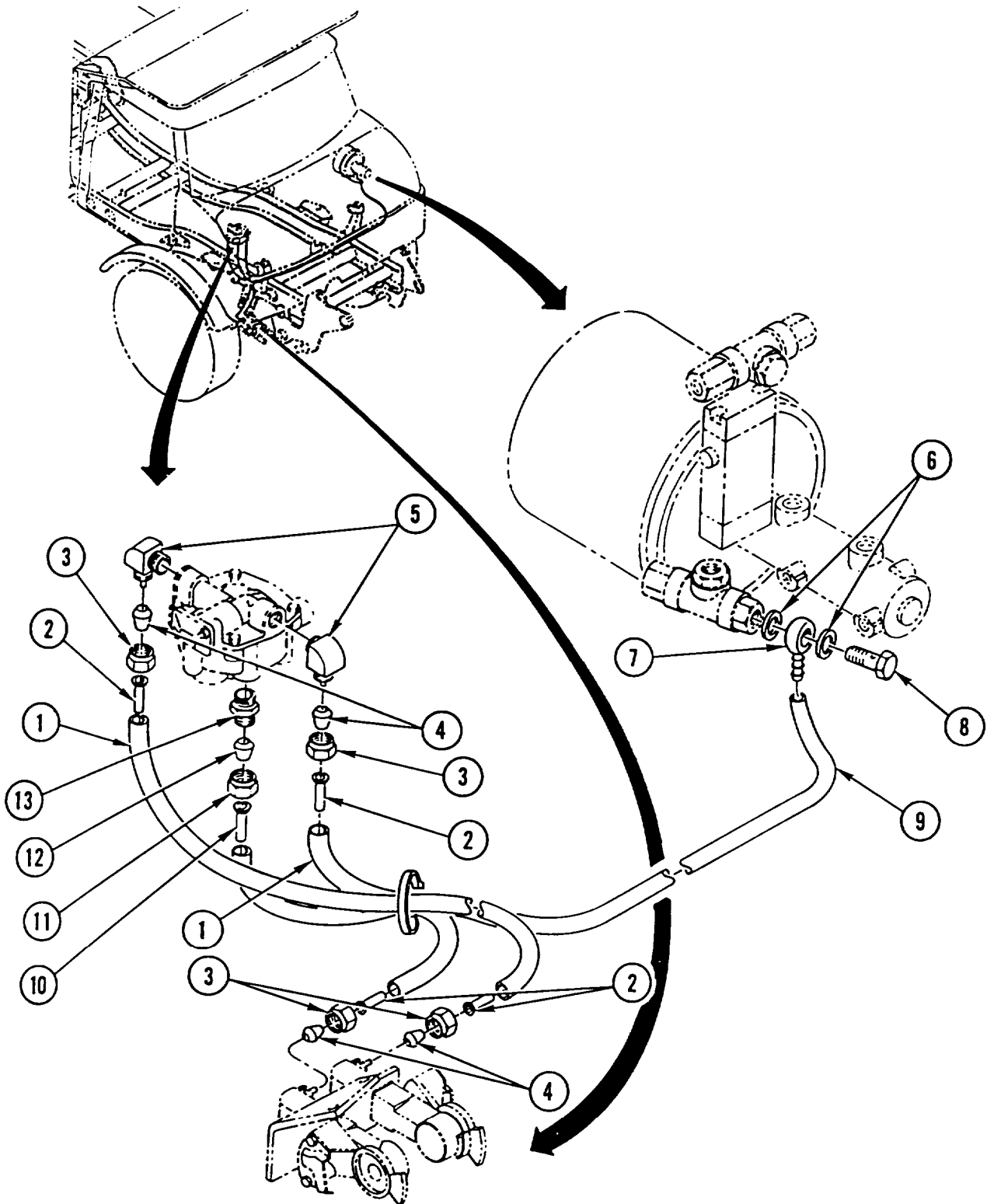

TANDEM VALVE REPLACEMENT

This task covers: a. Removal b. Installation

INITIAL SETUP

Tools and Special Equipment:

Tool Kit, SC 5180-90-CL-N26

Materials/Parts:

Seal (4)

Nut, Lock

Equipment Condition:

Reference	Condition Description
Page 4-388	Outside Engine Hood Removed
Page 2-23	Air Pressure Relieved

General Safety Instructions:

WARNING

Do not disconnect any air system lines or fittings unless vehicle engine is shut off and air system pressure is relieved. To do so could result in injury to personnel.

REMOVAL

NOTE

Tag all lines prior to disconnecting to aid in connecting.

1. REMOVE hollow SCREW (1) and two seals (2) and DISCONNECT air LINE (3) from tandem valve (4). DISCARD SEALS.
2. LOOSEN NUT (5) and DISCONNECT air LINE (6) from tandem valve (4).
3. LOOSEN NUT (7) and DISCONNECT air LINE (8) from tandem valve (4).
4. REMOVE lock nut (9), washer (10), capscrew (11), and tandem VALVE (4) from bracket (12). DISCARD lock NUT.
5. REMOVE two FITTINGS (13) and two seals (14) from tandem valve (4). DISCARD SEALS.

TANDEM VALVE REPLACEMENT (CONT)

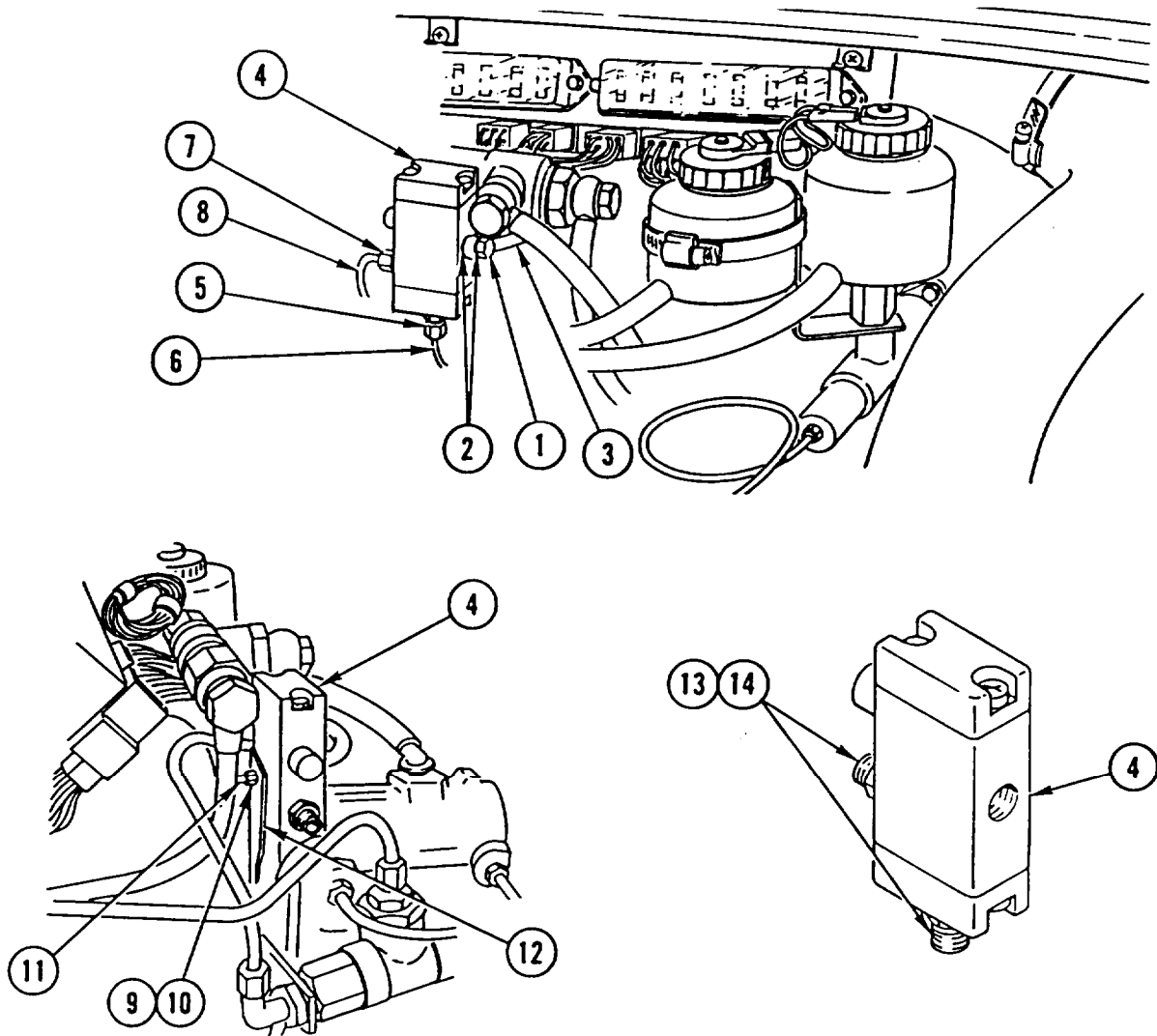

INSTALLATION

1. INSTALL two new seals (14) and two FITTINGS (13) on tandem valve (4).
2. INSTALL tandem VALVE (4), capscrew (11), washer (10), and new lock nut (9) on bracket (12).
3. CONNECT air LINE (8) to tandem valve (4) and TIGHTEN NUT (7).
4. CONNECT air LINE (6) to tandem valve (4) and TIGHTEN NUT (5).
5. INSTALL two new seals (2) and hollow SCREW (1) and CONNECT air LINE (3) to tandem valve (4).

NOTE

Follow-on Maintenance:
Install outside engine hood (page 4-388).

AIR SYSTEM SUPPLY LINES AND FITTINGS REPLACEMENT

This task covers: a. Removal b. Installation

INITIAL SETUP

Tools and Special Equipment:

Shop Equipment, SC 4910-95-CL-A74
Tool Kit, SC 5180-90-CL-N26

Materials/Parts:

Packing,
Preformed (AR)

Sleeve (AR)

Nut, Lock (AR)

Nut, Lock (AR)

Equipment Condition:

Reference

Page 2-23

Condition Description

Air Pressure Relieved

General Safety instructions:

WARNING

Do not disconnect any air system lines or fittings unless vehicle engine is shut off and air system pressure is relieved. To do so could result in injury to personnel.

REMOVAL

NOTE

- Tag lines prior to removal to aid in installation.
- Discard packing, sleeve(s), and lock nut(s).

REMOVE air system supply LINES and FITTINGS using illustration and legend as a guide.

INSTALLATION

NOTE

Install new packing, new sleeve(s), and new lock nut(s).

INSTALL air system supply LINES and FITTINGS using illustration and legend as a guide.

LEGEND

1 Packing	6 Clamp	11 Clamp	16 Nut (2)
2 Retainer	7 Tube	12 Screw	17 Tube
3 Adapter	8 Bracket	13 Nut	18 Lock nut
4 Nut	9 Screw	14 Adapter	19 Lock nut (2)
5 Screw (2)	10 Nut	15 Sleeve (2)	20 Bracket

AIR SYSTEM SUPPLY LINES AND FITTINGS REPLACEMENT (CONT)

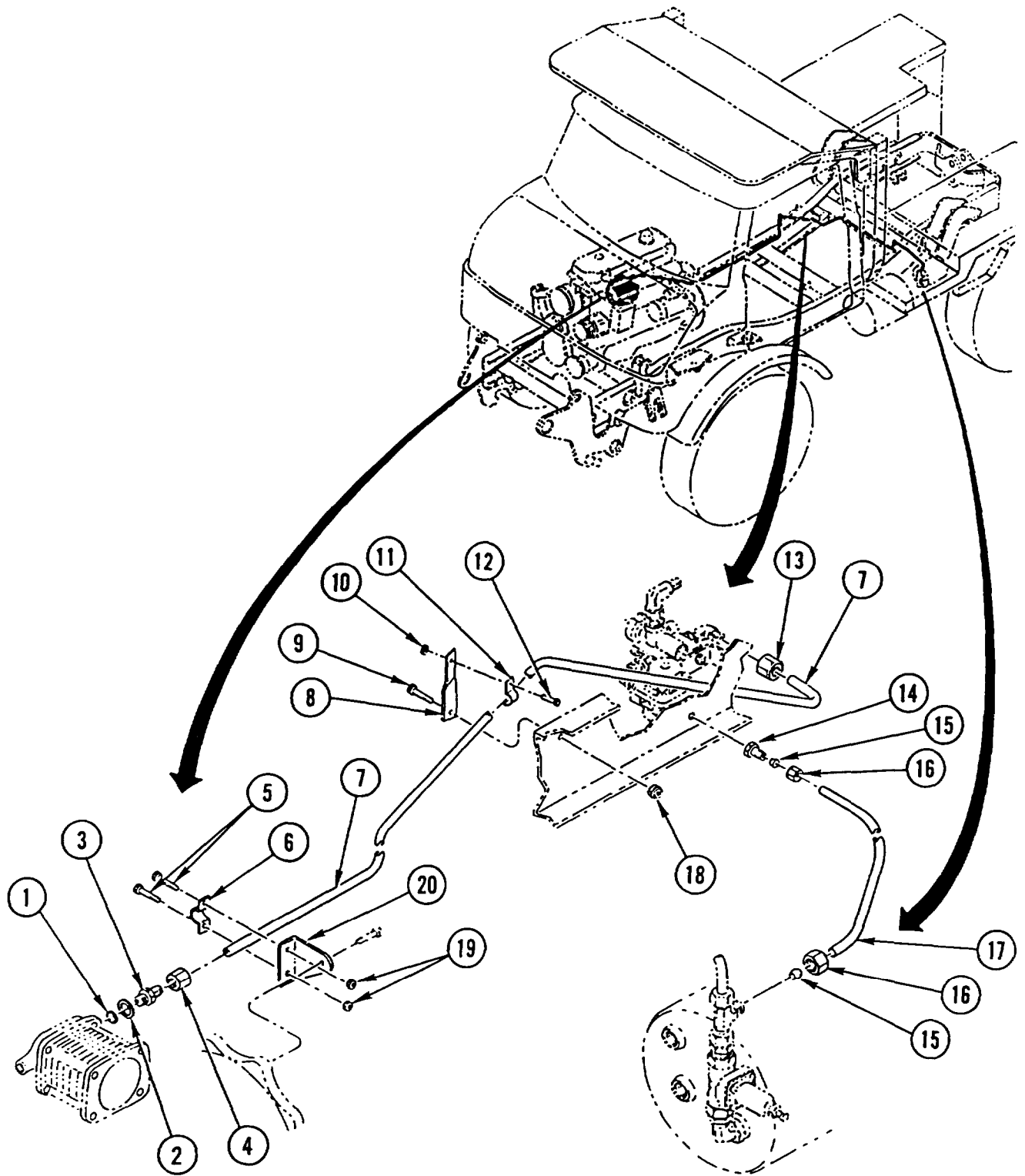

TRAILER HAND BRAKE VALVE REPLACEMENT

This task covers: a. Removal b. Installation

INITIAL SETUP

Tools and Special Equipment:

Tool Kit, SC 5180-90-CL-N26

Materials/Parts:

Washer, Lock (3)

Equipment Condition:

Reference	Condition Description
Page 2-23	Air Pressure Relieved

General Safety Instructions:

WARNING

Do not disconnect any air system lines or fittings unless vehicle engine is shut off and air system pressure is relieved. To do so could result in injury to personnel.

REMOVAL

1. LOOSEN jam NUT (1) and REMOVE LEVER (2).
2. REMOVE screw (3) and COVER (4).

NOTE

Tag lines prior to disconnecting to aid in connecting.

3. DISCONNECT air LINE (5) and two HOSES (6 and 7).
4. REMOVE three screws (8), three lock washers (9), and trailer hand' brake VALVE (10). DISCARD lock WASHERS.

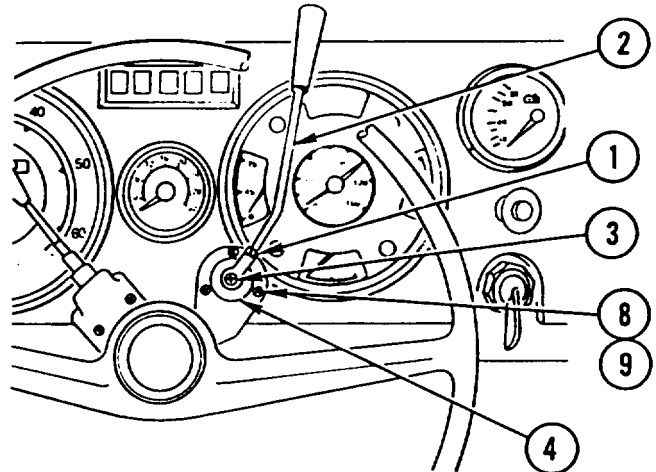

INSTALLATION

1. INSTALL trailer hand brake VALVE (10), three screws (8), and three new lock washers (9).
2. CONNECT air LINE (5) and two HOSES (6 and 7).
3. INSTALL COVER (4) and screw (3).
4. INSTALL LEVER (2) and TIGHTEN jam NUT (1).

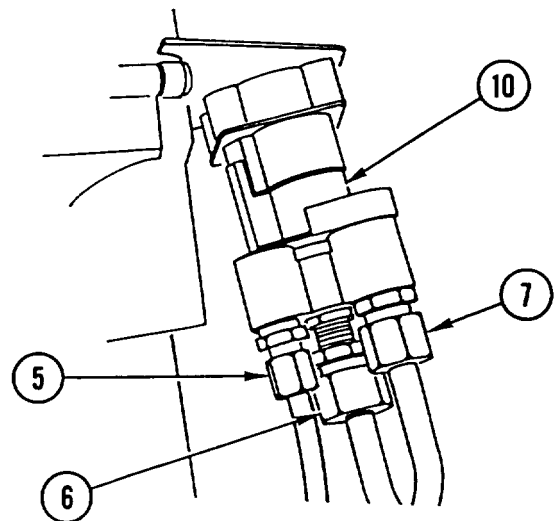

TRAILER AIR SUPPLY LINES AND FITTINGS REPLACEMENT

This task covers: a. Removal b. Installation

INITIAL SETUP

Tools and Special Equipment:

Shop Equipment, SC 4910-95-CL-A74
Tool Kit, SC 5180-90-CL-N26

Materials/Parts:

Sleeve (AR)

Packing (AR)

Equipment condition:

Reference	Condition Description
Page 2-23	Air Pressure Relieved

General Safety instructions:

WARNING

Do not disconnect any air system lines or fittings **unless** vehicle engine is shut off and air system pressure is relieved. To do so could result in injury to personnel.

REMOVAL

NOTE

- Tag lines prior to removal to aid in installation.
- Discard sleeve(s) and packing(s).

REMOVE trailer air supply LINES and FITTINGS using illustration and legend as a guide.

INSTALLATION

NOTE

Install new sleeve(s) and new packing(s).

INSTALL trailer air supply LINES and FITTINGS using illustration and legend as a guide.

TRAILER AIR SUPPLY LINES AND FITTINGS REPLACEMENT (CONT)

LEGEND

- 1 Nut (4)
- 2 Washer (4)
- 3 Mounting bracket
- 4 Holder (2)
- 5 Packing (2)
- 6 Gladhand
- 7 Screw (4)
- 8 Elbow (2)
- 9 Sleeve (4)
- 10 Nut (4)
- 11 Insert (4)
- 12 Tube
- 13 Mounting bracket
- 14 Gladhand
- 15 Tube
- 16 Adapter (2)
- 17 Elbow

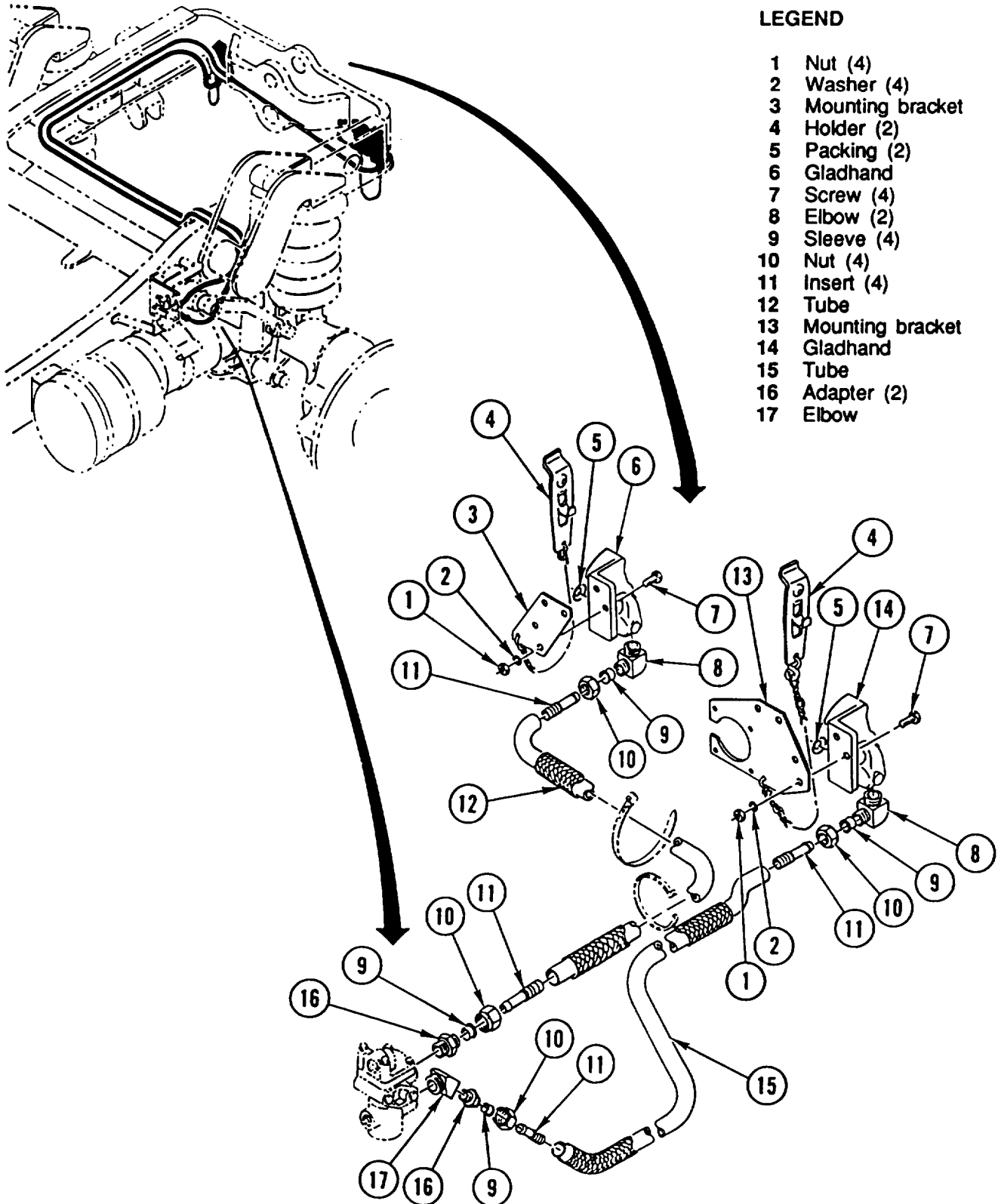

TRAILER HAND BRAKE VALVE LINES AND FITTINGS REPLACEMENT

This task covers: a. Removal b. Installation

INITIAL SETUP

Tools and Special Equipment:

Shop Equipment, SC 4910-95-CL-A74
 Tool Kit, SC 5180-90-CL-N26

General Safety instructions:

WARNING

Do not disconnect any air system lines or fittings unless vehicle engine is shut off and air system pressure is relieved. To do so could result in injury to personnel.

Materials/Parts:

Seal (AR)

Sleeve (AR)

Equipment Condition:

Reference	Condition Description
Page 2-23	Air Pressure Relieved

REMOVAL

NOTE

- Tag lines prior to removal to aid in installation.
- Discard seal(s) and sleeve(s).

REMOVE trailer hand brake valve LINES and FITTINGS using illustration and legend as a guide.

INSTALLATION

NOTE

Install new seal(s) and new sleeve(s).

INSTALL trailer hand brake valve LINES and FITTINGS using illustration and legend as a guide.

TRAILER HAND BRAKE VALVE LINES AND FITTINGS REPLACEMENT (CONT)

LEGEND

- | | |
|----------------------|------------|
| 1 Seal (2) | 10 Tee |
| 2 Line | 11 Line |
| 3 Fluid passage bolt | 12 Hose |
| 4 Nut (5) | 13 Sleeve |
| 5 Sleeve (5) | 14 Nut |
| 6 Adapter | 15 Sleeve |
| 7 Washer | 16 Adapter |
| 8 Nut | 17 Adapter |
| 9 Line | |

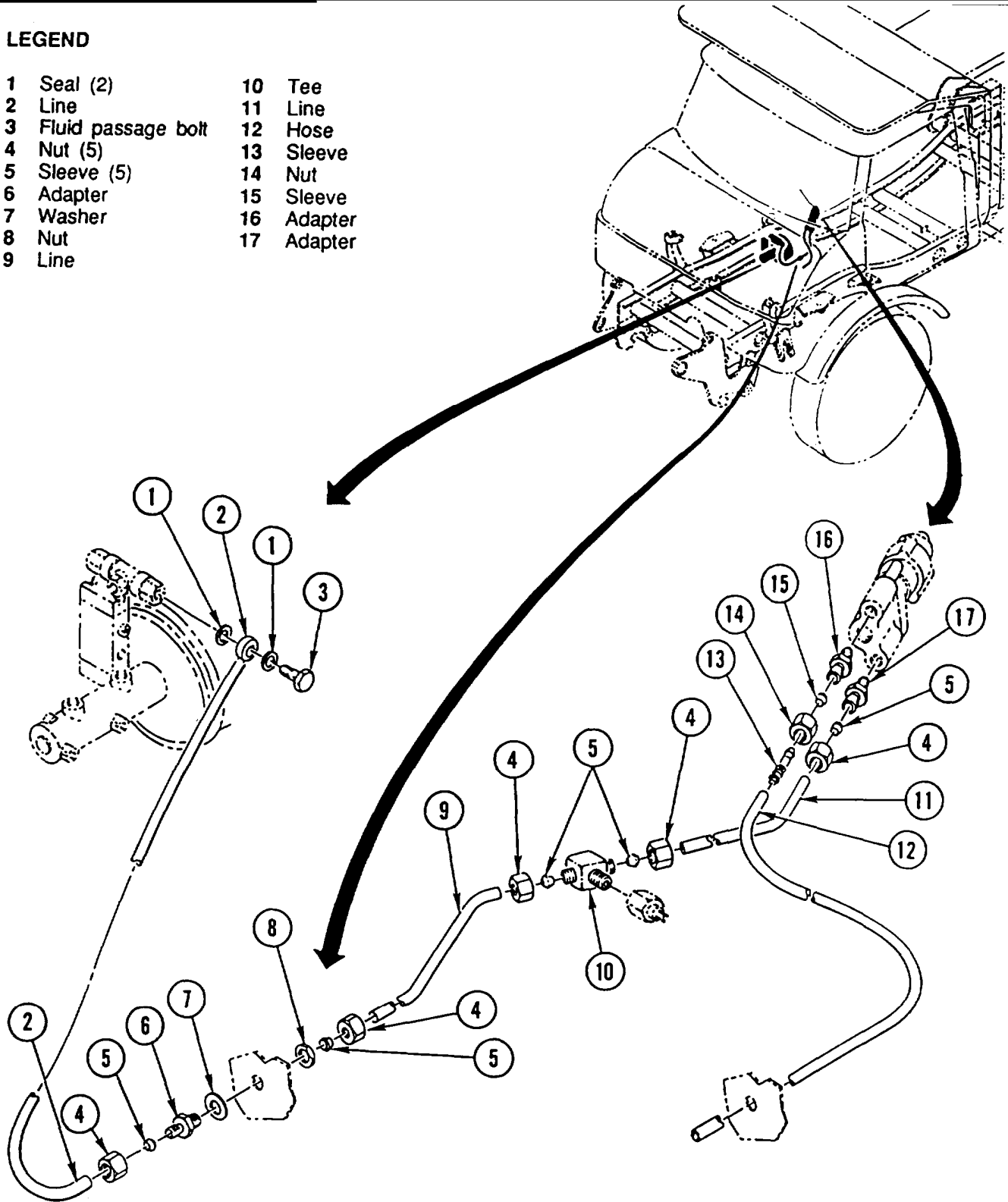

TRAILER AIR SUPPLY VALVE REPLACEMENT

This task covers: a. Removal b. installation

INITIAL SETUP

Tools and Special Equipment:

Tool Kit, SC 5180-90-CL-N26

Equipment Condition:

Reference	Condition Description
Page 4-418	Cab Tilted
Page 2-23	Air Pressure Relieved

General Safety instructions:

WARNING

Do not disconnect any air system lines or fittings unless vehicle engine is shut off and air system pressure is relieved. To do so could result in injury to personnel.

REMOVAL

NOTE

Tag lines prior to disconnecting to aid in connecting.

1. Disconnect two LINES (1) from trailer air supply valve (2).
2. LOOSEN NUT (3) and REMOVE KNOB (4) and nut (3) from valve (2).
3. REMOVE two nuts (5), two screws (6), and VALVE (2).
4. REMOVE two elbows (7) and two ADAPTERS (8) from valve (2).

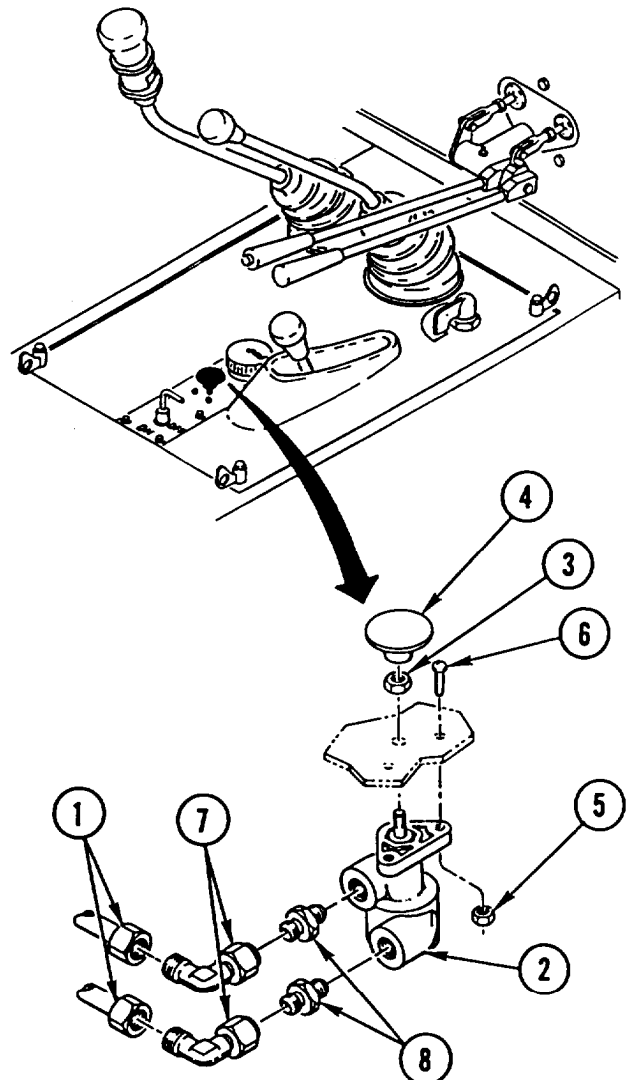

INSTALLATION

1. INSTALL two ADAPTERS (8) and two elbows (7) in trailer air supply valve (2).
2. INSTALL VALVE (2), two screws (6), and two nuts (5).
3. INSTALL nut (3) and KNOB (4) on valve (2) and TIGHTEN NUT (3).
4. CONNECT two LINES (1) to valve (2).

NOTE

Follow-on Maintenance:
Lower cab (page 4-418).

TRACTOR PROTECTION VALVE REPLACEMENT

This task covers: a. Removal b. Installation

INITIAL SETUP

Tools and Special Equipment:

Shop Equipment, SC 4910-95-CL-A74
 Tool Kit, SC 5180-90-CL-N26

Materials/Parts:

Washer, Lock (2)

Equipment Condition:

Reference	Condition Description
Page 2-23	Air Pressure Relieved

General Safety Instructions:

WARNING

Do not disconnect any air system lines or fittings unless vehicle engine is shut off and air system pressure is relieved. To do so could result in injury to personnel.

REMOVAL

NOTE

Tag lines prior to disconnecting to aid in connecting.

1. Disconnect four LINES (1) from tractor protection valve (2).
2. REMOVE two nuts (3), two lock washers (4), two screws (5), and VALVE (2), DISCARD lock WASHERS.
3. REMOVE union (6), four adapters (7), and ELBOW (8) from valve (2).

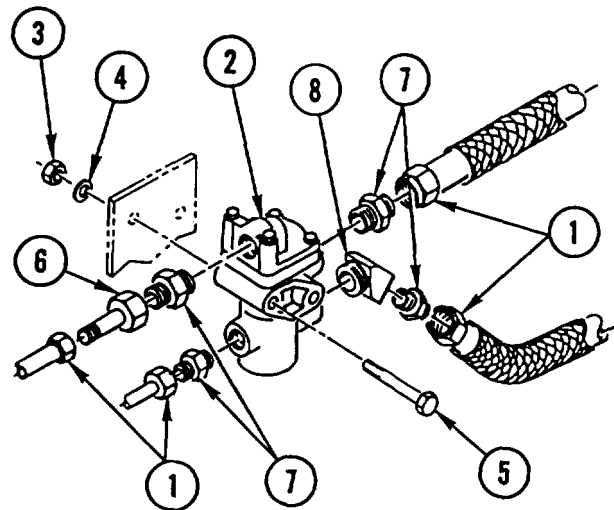
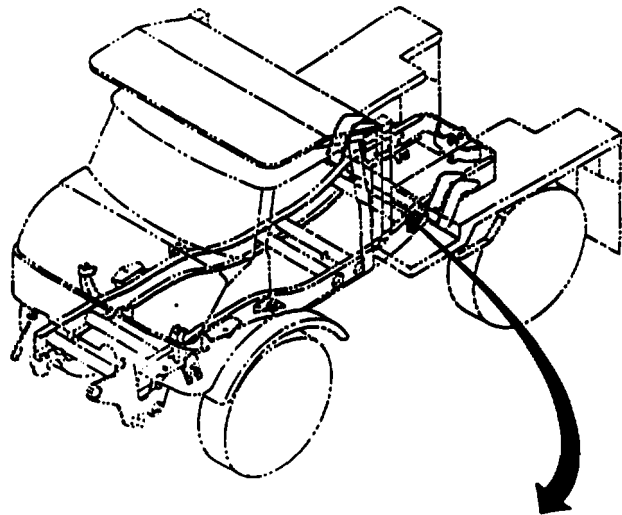

INSTALLATION

1. INSTALL ELBOW (8), four adapters (7), and union (6) in tractor protection valve (2).
2. INSTALL VALVE (2), two screws (5), two new lock washers (4), and two nuts (3).
3. CONNECT four LINES (1) to valve (2).

TRAILER HAND BRAKE AIR SUPPLY LINES AND FITTINGS REPLACEMENT

This task covers: a. Removal b. Installation

INITIAL SETUP

Tools and Special Equipment:

Shop Equipment, SC 4910-95-CL-A74
 Tool Kit, SC 5180-90-CL-N26

Materials/Parts:

Sleeve (AR)

Equipment Condition:

Reference	Condition Description
Page 2-23	Air Pressure Relieved

General Safety Instructions:

WARNING

Do not disconnect any air system lines or fittings unless vehicle engine is shut off and air system pressure is relieved. To do so could result in injury to personnel.

REMOVAL

NOTE

- Tag lines prior to removal to aid in Installation.
- Discard sleeve(s).

REMOVE trailer hand brake air supply LINES and FITTINGS using illustration and legend as a guide.

INSTALLATION

NOTE

Install new sleeve(s).

INSTALL trailer hand brake air supply LINES and FITTINGS using illustration and legend as a guide.

TRAILER HAND BRAKE AIR SUPPLY LINES AND FITTINGS REPLACEMENT (CONT)

LEGEND

- | | |
|--------------|----------------|
| 1 Tube | 10 Nut (4) |
| 2 Adapter | 11 Clamp (2) |
| 3 Nut (4) | 12 Screw (4) |
| 4 Sleeve (4) | 13 Bracket |
| 5 Adapter | 14 Tube |
| 6 Washer | 15 Nut (2) |
| 7 Nut | 16 Sleeve (2) |
| 8 Tube | 17 Adapter (2) |
| 9 Adapter | 18 Tube |

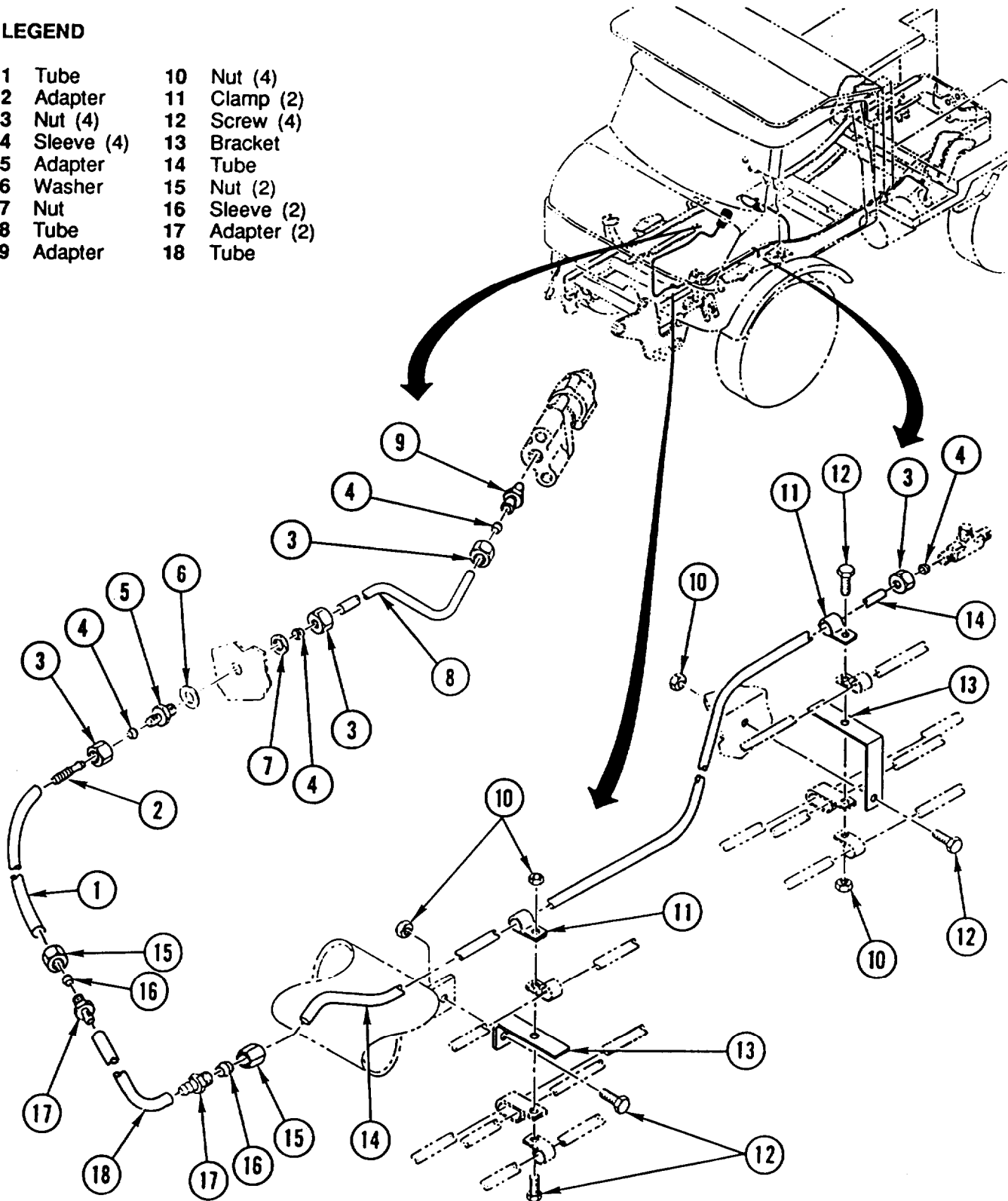

Section X. WHEEL MAINTENANCE

OVERVIEW

This section illustrates and describes procedures for maintenance of the wheels and related parts. A list of tasks contained in this section is shown below.

	Page
Wheel Assembly Replacement	4-335
Tire Replacement	4-337

WHEEL ASSEMBLY REPLACEMENT

This task covers: a. Removal b. Installation

I N I T I A L

Tools and Special Equipment:

Shop Equipment, SC 4910-95-CL-A74

Personnel Required: (3)

Equipment Condition:

Reference	Condition Description
Page 4-390	Spare Tire and Mount Removed (SEE)
Page 4-391	Spare Tire and Mount Removed (HMMH)

General Safety Instructions:

WARNING

Make sure parking brake is set and that wheels not being lifted are blocked. Failure to do so could result in serious injury to personnel.

Wheel assembly weighs 170 pounds (77 kilograms). To avoid personal injury, use a hoist or suitable lifting device when lifting wheel assembly.

WHEEL ASSEMBLY REPLACEMENT (CONT)

REMOVAL

CAUTION

Place jack away from corresponding axle pipes, lines, differential housing, and fittings to prevent damage to equipment.

NOTE

- Procedure is the same for both vehicles.
- Procedure is the same for all wheels.

1. LOOSEN six NUTS (1).
2. RAISE VEHICLE using jack.

REMOVE six nuts (1) and TIRE (2).

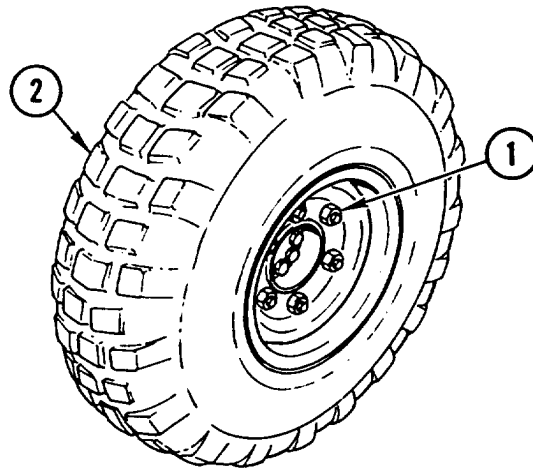

INSTALLATION

NOTE

- Procedure is the same for both vehicles.
- Procedure is the same for all wheels.

1. INSTALL TIRE (2) and six nuts (1).
2. LOWER VEHICLE to ground level and REMOVE JACK.
3. TIGHTEN six NUTS (1) to 260 lb-ft (352 N.m).

NOTE

Follow-on Maintenance:

Install spare tire and mount (SEE) (page 4-390).
Install spare tire and mount (HMMH) (page 4-391).

TIRE REPLACEMENT

This task covers: a. Removal b. Installation

INITIAL SETUP

Tools and Special Equipment:

Shop Equipment, SC 4910-95-CL-A74

Personnel Required: (2)

References:

TM 9-2610-200-24

Equipment Condition:

Reference	Condition Description
Page 4-335	Wheel Assembly Removed

REMOVAL

NOTE

Tires can be mounted in ANY DIRECTION.

Procedure is the same for all tires.

REMOVE TIRE (1) from wheel rim (2) (TM 9-2610-200-24).

INSTALLATION

NOTE

Procedure is the same for all tires.

INSTALL TIRE (1) on wheel rim (2) (TM 9-2610-200-24).

NOTE

Follow-on Maintenance:
Install wheel assembly (page 4-335).

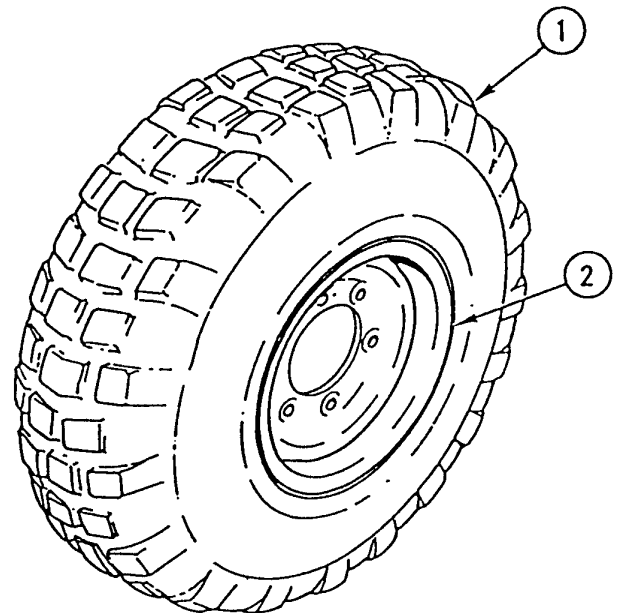

Section XI. STEERING MAINTENANCE

OVERVIEW

This section illustrates and describes procedures for maintenance of the steering and related parts. A list of tasks contained in this section is shown below.

	Page
Tie Rod Replacement and Repair	4-338
Tie Rod and Steering Stop Adjustment	4-341
Steering Wheel Replacement	4-343
Steering Wheel Bracket and Seal Replacement	4-344
Drag Link Replacement and Adjustment	4-346
Steering Arm Replacement	4-349
Steering Upper Shaft Bearing Replacement	4-351
Power Steering Gear Adjustment	4-354
Power Steering Pump Belt Replacement and Adjustment	4-356
Power Steering Lines and Fittings Replacement	4-357
Power Steering Filter Element Replacement	4-359
Power Steering Tank (Reservoir) Replacement	4-360

TIE ROD REPLACEMENT AND REPAIR

This task covers: a. Removal b. Disassembly c. Assembly d. Installation

INITIAL SETUP

Tools and Special Equipment:

Shop Equipment, SC 4910-95-CL-A74
 Tool Kit, SC 5180-90-CL-N26
 Removal Tool, P/N 406 589 05 33 00

Materials/Parts:

Pin, Cotter (2)
 Boot, Rubber (2)
 Washer, Lock (2)

Personnel Required: (2)

Equipment Condition:

Reference	Condition Description
Page 2-22	Vehicle Blocked

TIE ROD REPLACEMENT AND REPAIR (CONT)

REMOVAL

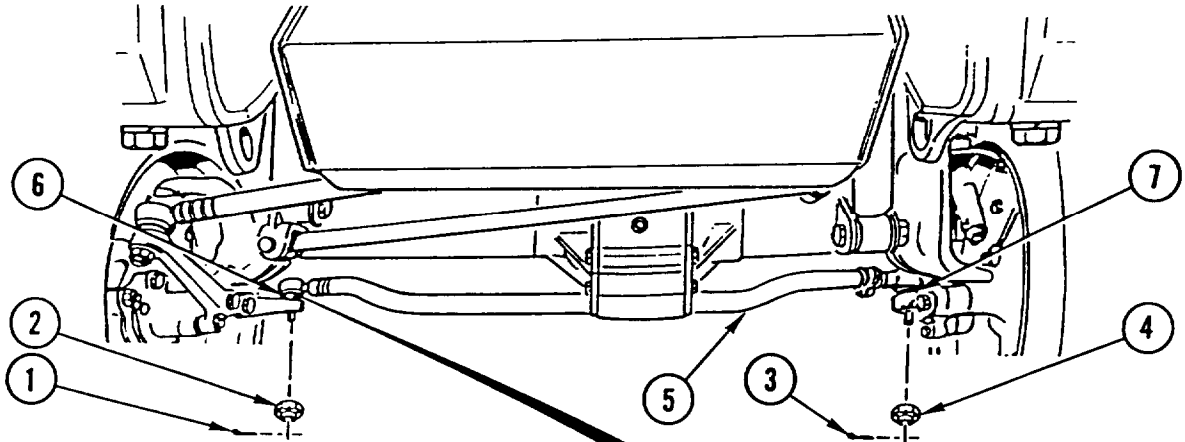

1. REMOVE cotter pin (1) and castellated NUT (2). DISCARD cotter PIN.
2. REMOVE cotter pin (3) and castellated NUT (4). DISCARD cotter PIN.
3. USING REMOVAL TOOL, DISCONNECT end of tie ROD (5) and REMOVE rubber BOOT (6). DISCARD rubber BOOT.
4. USING REMOVAL TOOL, REMOVE tie ROD (5) and rubber BOOT (7). DISCARD rubber BOOT.

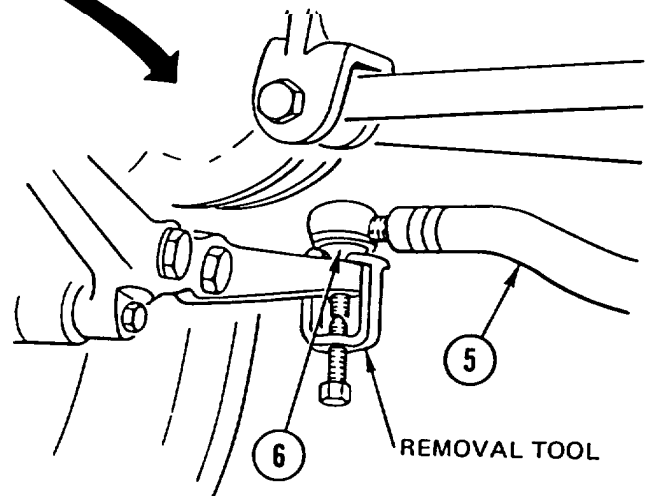

DISASSEMBLY

NOTE

Procedure is the same for both sides.

1. REMOVE NUT (1), lock WASHER (2), and SCREW (3). DISCARD lock WASHER.
2. REMOVE JOINT (4) and clamp (5).

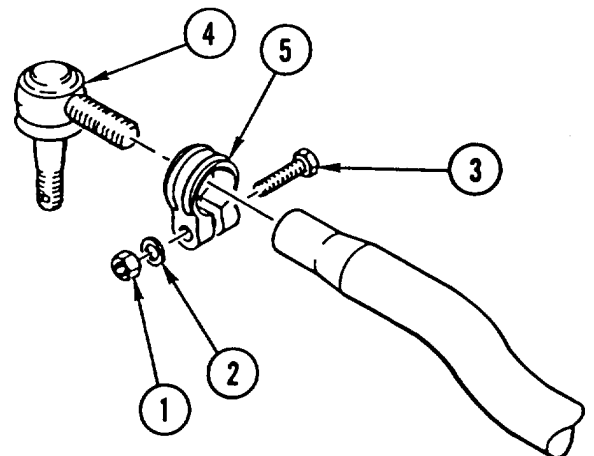

TIE ROD REPLACEMENT AND REPAIR (CONT)

ASSEMBLY

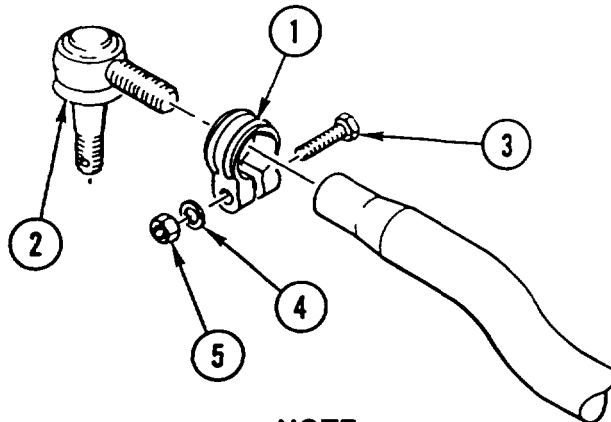

NOTE

Procedure is the same for both sides.

1. INSTALL clamp (1) and JOINT (2).
2. INSTALL SCREW (3), new lock WASHER (4), and NUT (5).

INSTALLATION

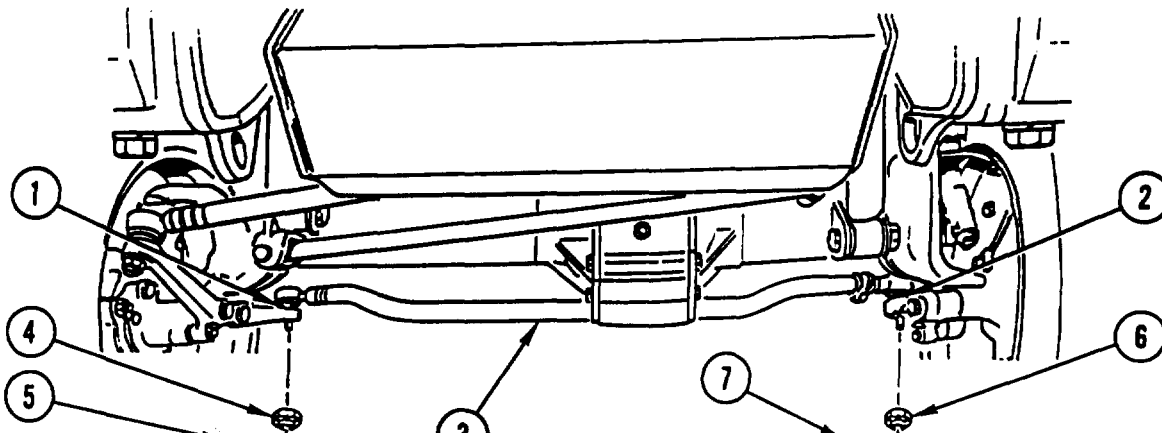

1. INSTALL two new rubber boots (1 and 2) and tie ROD (3).
2. INSTALL castellated NUT (4) and TIGHTEN to 111 lb-ft (150 N.m).
3. INSTALL new cotter PIN (5).
4. INSTALL castellated NUT (6) and TIGHTEN to 111 lb-ft (150 N.m).
5. INSTALL new cotter PIN (7).

NOTE

Follow-on Maintenance:

Adjust tie rod (page 4-341).

TIE ROD AND STEERING STOP ADJUSTMENT

This task covers: Adjustment

INITIAL SETUP

Tools and Special Equipment:

Tool Kit, SC 5180-90-CL-N26

Personnel Required: (2)

General Safety Instructions:

WARNING

Make sure wheels are properly chocked to prevent roll off and possible injury to personnel.

ADJUSTMENT

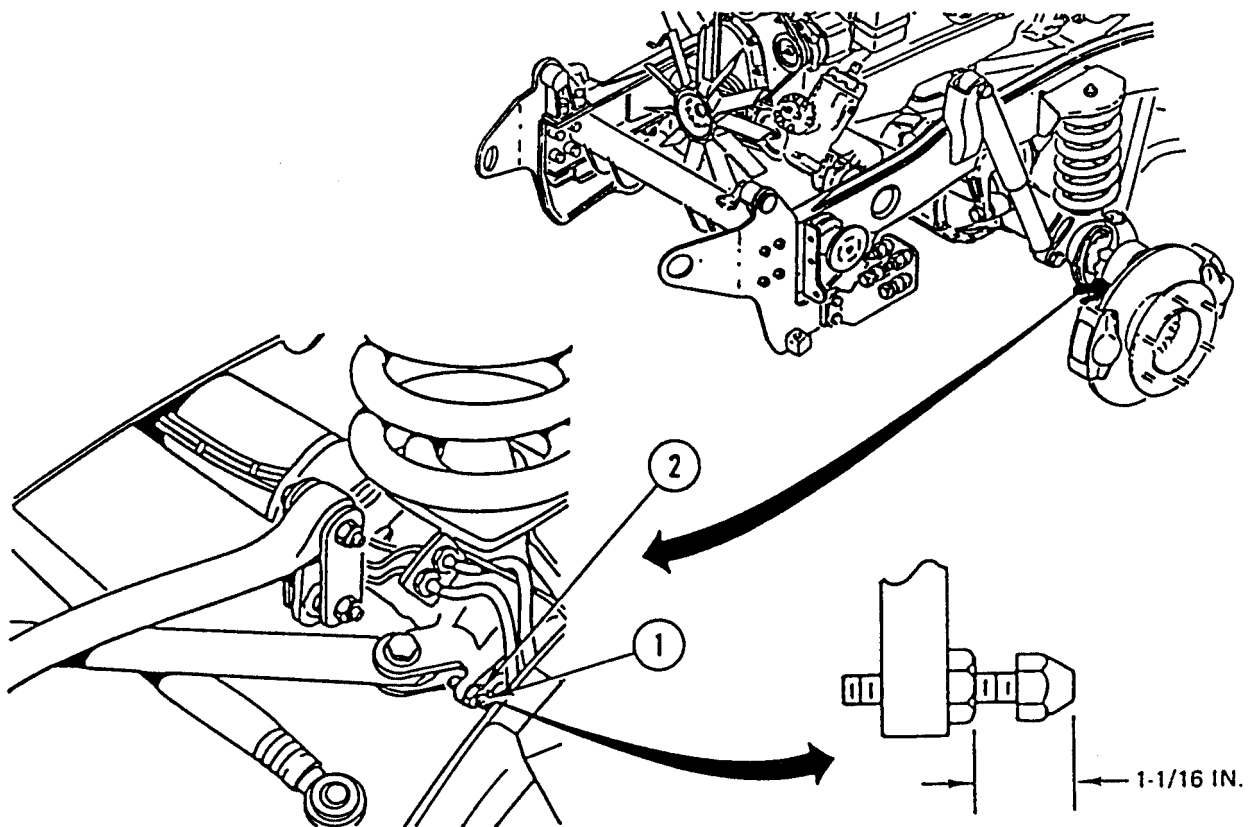

1. Measure length of stop bolt (1). Length must be $1\text{-}1/16 \pm 1/16$ in. (27 ± 1.5 mm). If measurement is not within tolerance, loosen lock nut (2) and adjust stop bolt (1) to required length.
2. Tighten lock nut (2).

TIE ROD AND STEERING STOP ADJUSTMENT (CONT)

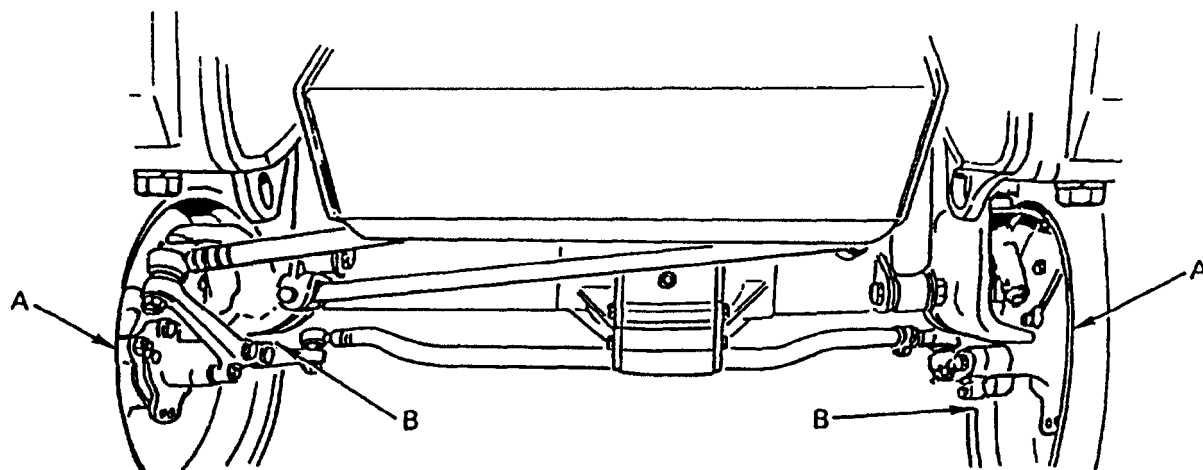

NOTE

Front wheels are considered centered when measurement is taken from inside front wheel to chassis on both sides and both measurements are equal.

3. Place vehicle on flat, level surface and center front wheels.

NOTE

Following measurement must be taken at wheel center height.

4. Measure from forward inside edge of rim A of one wheel to forward inside edge of wheel A on opposite side of vehicle. Record measurement.
5. Measure from rear inside edge of rim B of one wheel to rear inside edge of wheel B on opposite side of vehicle. Record measurement.
6. Subtract measurement A from measurement B. This is the toe-in angle and must be equal to 0 +1/8 in. or -1/32 in. (0 +3 mm or -1 mm). If toe-in angle is not within specified range, tie rod must be adjusted.
7. Remove left end of tie rod (page 4-338).
8. Loosen nut and clamp to allow left end of tie rod to be rotated freely.
9. Adjust tie rod by turning left end of tie rod in or out and temporarily install tie rod. Repeat steps 4 thru 6 until proper measurement is made.
10. After adjustment is made, reposition clamp and tighten nut.
11. Install tie rod on vehicle (page 4-338).
12. After tie rod has been installed, start vehicle and move vehicle forward while turning steering wheel full left and full right. Center wheels and repeat steps 4 thru 6. If necessary, readjust toe-in angle until specifications in step 6 are met.

STEERING WHEEL REPLACEMENT

This task covers: a. Removal b. Installation

INITIAL SETUP

Tools and Special Equipment:

Shop Equipment, SC 4910-95-CL-A74
Tool Kit, SC 5180s-90-CL-N26

Materials/Parts:

Washer, Spring
Tension

REMOVAL

1. REMOVE plastic CAP (1).
2. REMOVE NUT (2) and spring tension washer (3). DISCARD spring tension WASHER.
3. USING steering wheel PULLER, REMOVE steering WHEEL (4).

INSTALLATION

1. INSTALL steering WHEEL (4).
2. INSTALL new spring tension washer (3) and NUT (2). TIGHTEN NUT to 55 Ib-ft (75 N.m).
3. INSTALL plastic CAP (1).

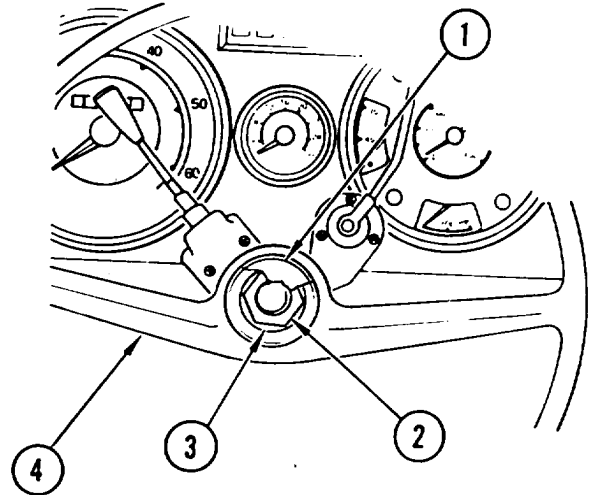

STEERING WHEEL BRACKET AND SEAL REPLACEMENT

This task covers: a. Removal b. Installation

INITIAL SETUP

Tools and Special Equipment:

Tool Kit, SC 5180-90-CL-N26

Equipment Condition:

Reference	Condition	Description
-----------	-----------	-------------

Materials/Parts:

Page 4-215	Horn, Low Beam/High Beam Switch	Removed
------------	---------------------------------	---------

Washer, Lock (2)

Page 4-326	Trailer Hand Brake Valve	Removed
------------	--------------------------	---------

Washer, Spring Tension (2)

Page 4-351	Steering Upper Shaft Bearing	Removed
------------	-------------------------------------	----------------

REMOVAL

1. REMOVE two BOLTS (1), two washers (2), and two lock washers (3) from steering bracket (4). DISCARD lock WASHERS.
2. REMOVE two screws (5), two washers (6), two spring tension washers (7), and steering BRACKET (4) from steering shaft (8). DISCARD spring tension WASHERS.
3. REMOVE two edge GUARDS (9) from steering bracket (4).
4. REMOVE five screws (10), five washers (11), spacer (12), and FRAME (13).
5. REMOVE six screws (14), six washers (15), and FRAME (16).

NOTE

Perform step 6 only if seal is damaged.

6. REMOVE hose clamp (17), COVER (18) and seal (19) from steering shaft (8).

STEERING WHEEL BRACKET AND SEAL REPLACEMENT (CONT)

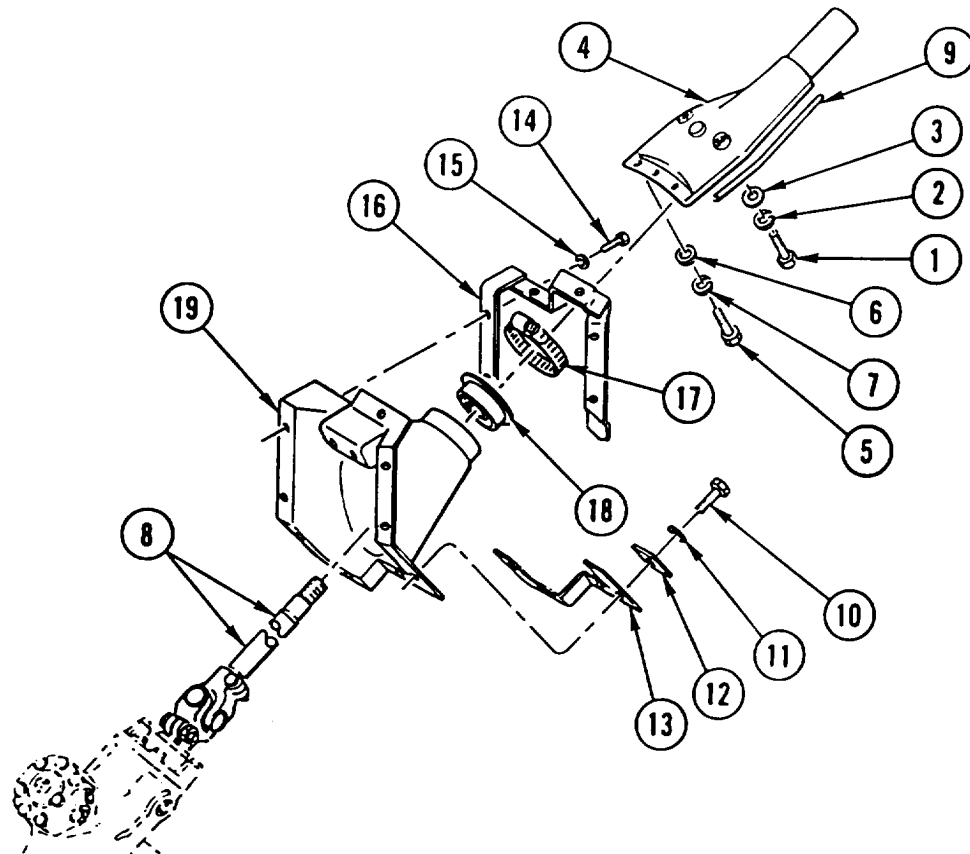
INSTALLATION
NOTE

Perform step 1 only if seal was removed.

1. INSTALL new seal (19), COVER (18), and hose clamp (17) on steering shaft (8).
2. INSTALL FRAME (16), six washers (15), and six screws (14).
3. INSTALL FRAME (13), spacer (12), five washers (11), and five screws (10).
4. INSTALL two edge GUARDS (9) on steering bracket (4).
5. INSTALL steering BRACKET (4), two new spring tension washers (7), two washers (6), and two screws (5) on steering shaft (8).
6. INSTALL two new lock washers (3), two washers (2), and two BOLTS (1) on steering bracket (4).

NOTE

Follow-on Maintenance:

- Install steering upper shaft bearing (page 4-351).
- Install trailer hand brake valve (page 4-326).
- Install horn, low beam/high beam switch (page 4-215).

DRAG LINK REPLACEMENT AND ADJUSTMENT

This task covers: a. Removal b. Installation c. Adjustment

INITIAL SETUP

Tools and Special Equipment:

Shop Equipment, SC 4910-95-CL-A74
Tool Kit, SC 5180-90-CL-N26
Puller, P/N 406 589 05 33 00

Materials/Parts:

Pin, Cotter (2)
Boot, Rubber (2)
Personnel Required: (2)

Equipment Condition:

Reference	Condition Description
Page 2-22	Vehicle Blocked
Page 4-385	Front Plate Removed

General Safety Instructions:

WARNING

Support drag link during removal. Drag link end could drop causing personnel injury.

REMOVAL

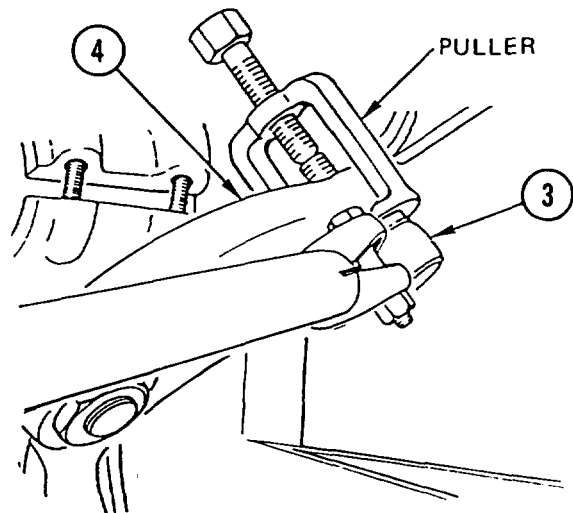
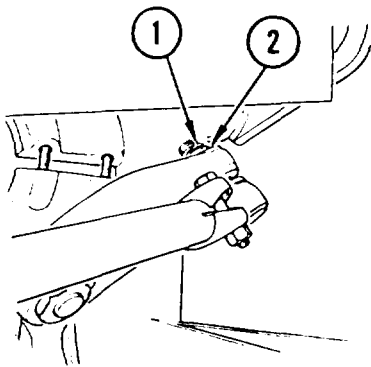

1. REMOVE cotter pin (1) and castellated NUT (2). DISCARD cotter PIN,
2. USING PULLER, REMOVE drag LINK (3) from pitman arm (4).

DRAG LINK REPLACEMENT AND ADJUSTMENT (CONT)

3. REMOVE cotter pin (5) and castellated NUT (6). DISCARD cotter PIN.

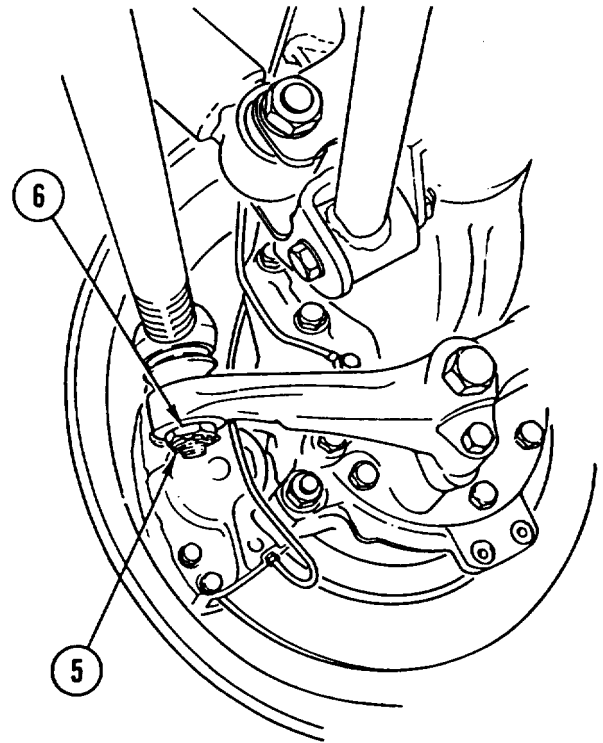

4. USING PULLER, REMOVE drag LINK (3) from steering arm (7).
5. REMOVE and DISCARD two rubber BOOTS (8).

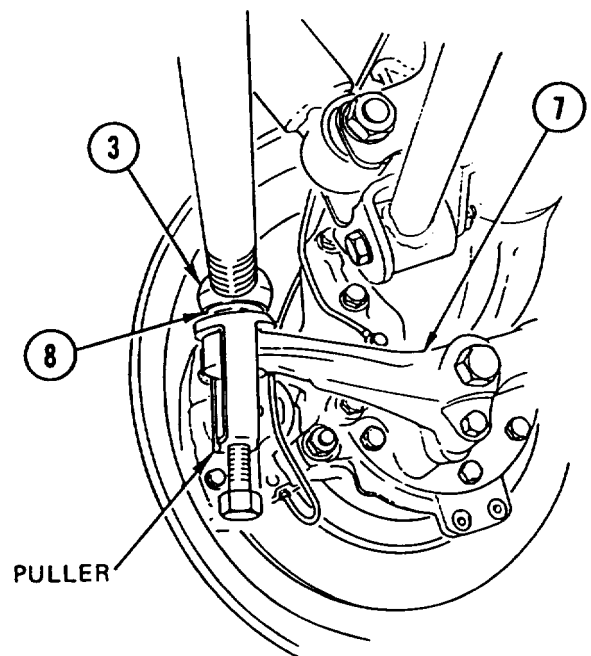

DRAG LINK REPLACEMENT AND ADJUSTMENT (CONT)

INSTALLATION

1. INSTALL two new rubber BOOTS (1).
2. INSTALL drag LINK (2) in steering arm (3).
3. INSTALL castellated NUT (4). TIGHTEN NUT to 107 lb-ft (145 N.m) and INSTALL new cotter PIN (5).

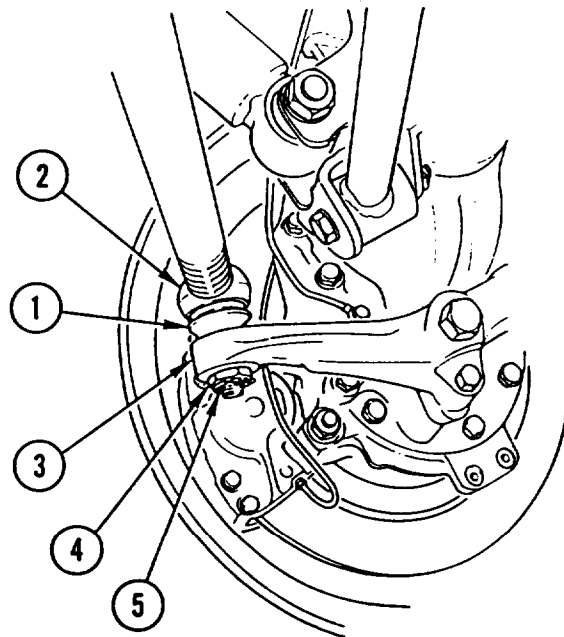

ADJUSTMENT

1. Loosen nut (1).
2. Rotate drag link (2) until it is aligned with pitman arm (3).
3. Install drag link (2) in pitman arm (3).
4. Install castellated nut (4). Tighten nut to 107 lb-ft (145 N.m) and Install new cotter pin (5).

NOTE

Follow-on Maintenance:
Install front plate (page 4-385).

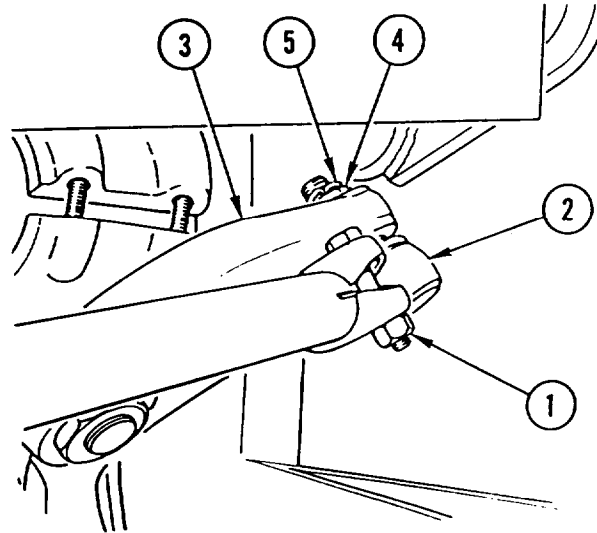

STEERING ARM REPLACEMENT

This task covers: a. Removal b. Installation

INITIAL SETUP

Tools and Special Equipment:

Shop Equipment, SC 4910-95-CL-A74
 Tool Kit, SC 5180-90-CL-N26

Materials/Parts:

Compound, Sealing Appendix C, Item 13

References:

None

Equipment Condition:

Reference	Condition Description
Page 2-22	Vehicle Blocked
Page 4-338	Tie Rod Removed
Page 4-346	Drag Link Removed

General Safety Warning:

WARNING

Adhesive causes immediate bonding on contact with eyes, skin, or clothing and also gives off harmful vapors. Wear protective goggles and use in well-ventilated area. If adhesive gets in eyes, try to keep eyes open; flush eyes with water for 15 minutes and get immediate medical attention.

REMOVAL

CAUTION

Make sure vehicle axle is supported on jack stands to prevent damage to vehicle.

1. REMOVE three SCREWS (1, 2, and 3) and steering ARM (4).

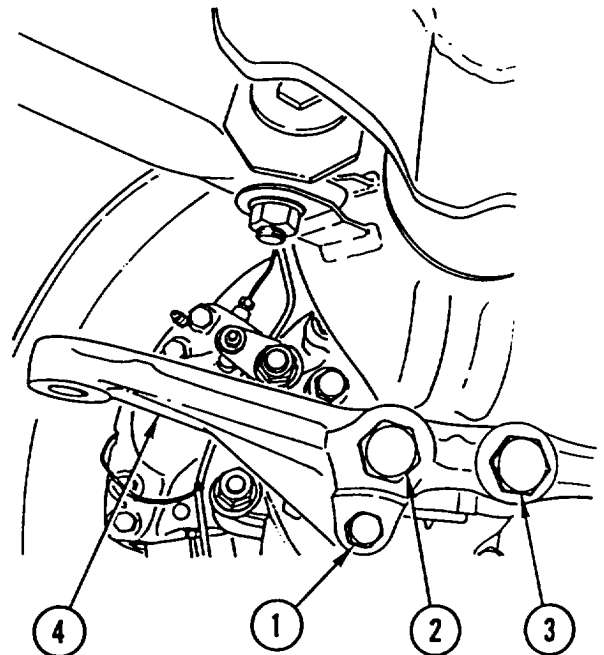

STEERING ARM REPLACEMENT (CONT)

- REMOVE three screws (5, 6, and 7) and steering ARM (8).

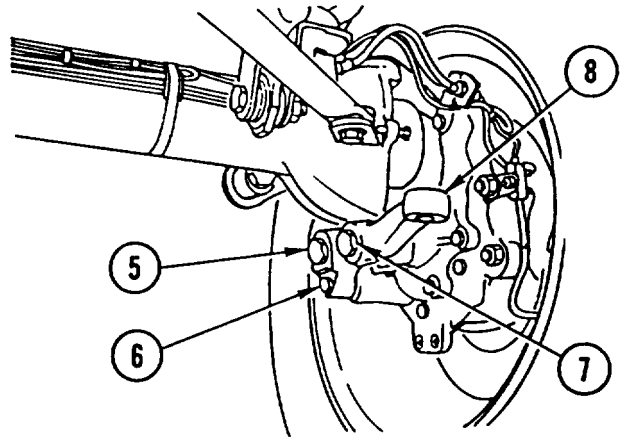

INSTALLATION

- APPLY COAT of SEALING COMPOUND to three SCREWS (1, 2, and 3) and INSTALL steering ARM (4) and three screws (1, 2, and 3). TIGHTEN two SCREWS (1 and 3) to 295 lb-ft (400 N.m) and SCREW (2) to 133 lb-ft (180 N.m).
- APPLY COAT of SEALING COMPOUND to three SCREWS (5, 6, and 7) and INSTALL steering ARM (8) and three screws (5, 6, and 7). TIGHTEN SCREW (5) to 133 lb-ft (180 N.m) and two SCREWS (6 and 7) to 295 lb-ft (400 N.m).

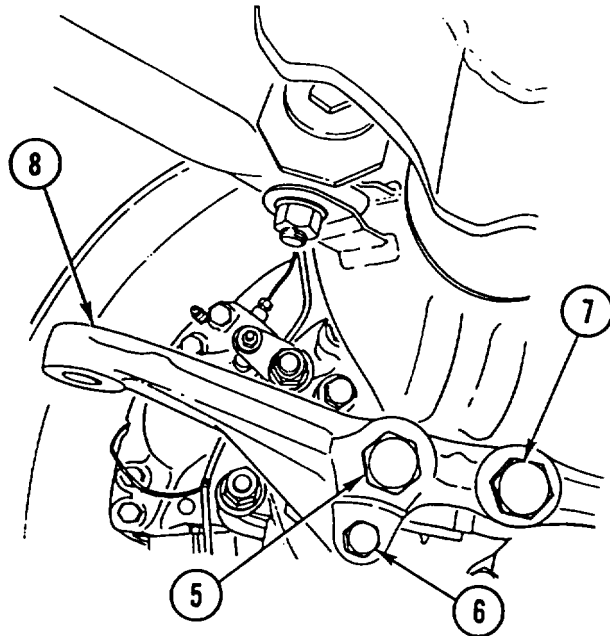
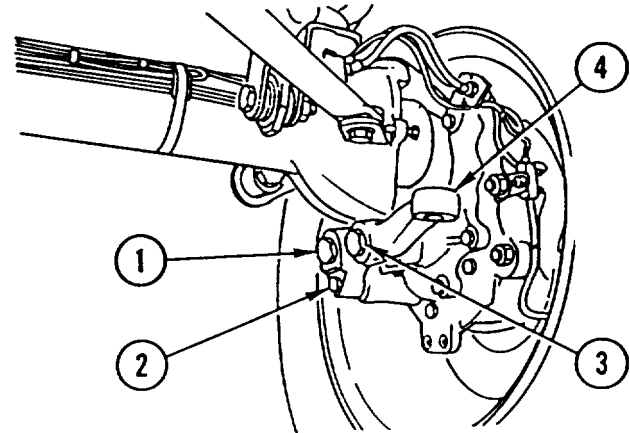

NOTE

Follow-on Maintenance:
 Install tie rod (page 4-338).
 Install drag link (page 4-346).
 Service hubs with oil (page 2-14).

STEERING UPPER SHAFT BEARING REPLACEMENT

This task covers: a. Removal b. Installation

INITIAL SETUP

Tools and Special Equipment:

Shop Equipment, SC 4910-95-CL-A74
 Tool Kit, SC 5180-90-CL-N26

Equipment Condition:

Reference

Page 4-388

Condition Description

Outside Engine Hood
 Removed

REMOVAL

1. USING steering wheel PULLER, REMOVE plastic CAP (1), nut (2), washer (3), and steering WHEEL (4).
2. REMOVE nut (5) and SCREW (6) from top of universal joint (7).
3. INSTALL steering WHEEL (4) on steering shaft (8) enough to INSTALL washer (3) and NUT (2).

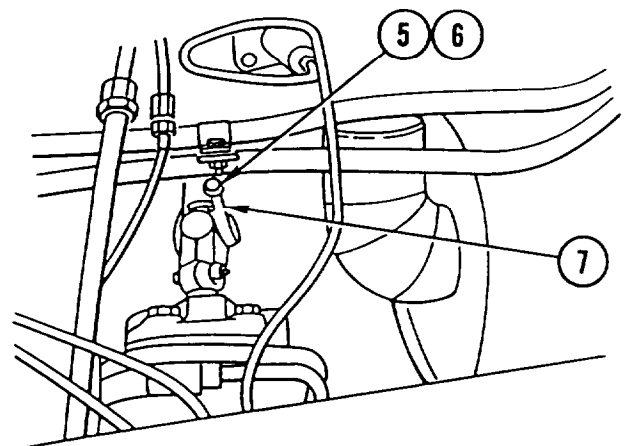
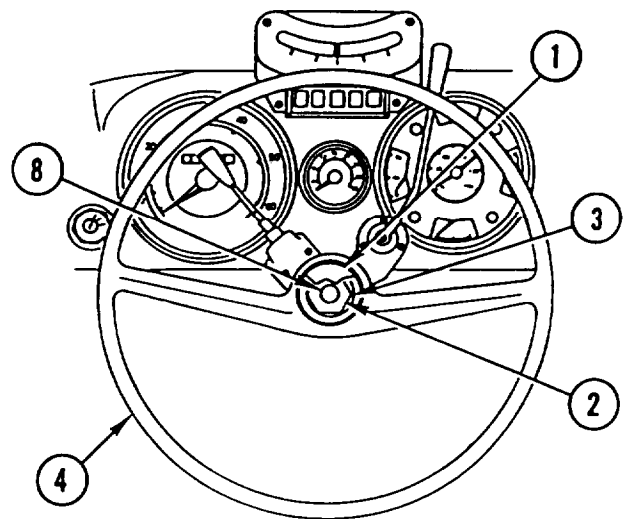

STEERING UPPER SHAFT BEARING REPLACEMENT (CONT)

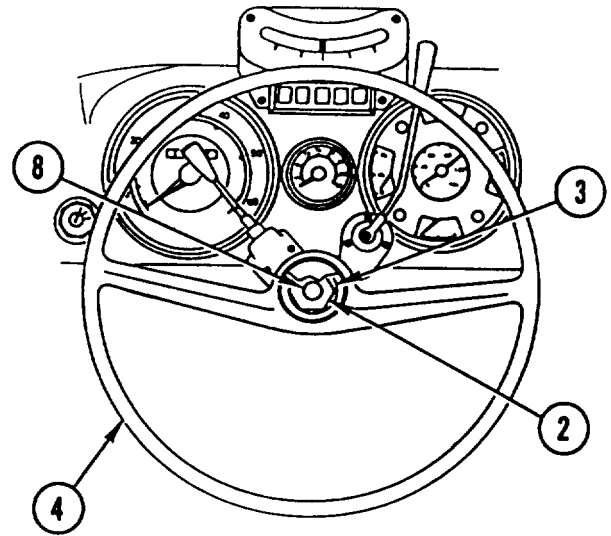

4. BY PULLING on steering WHEEL, PULL steering SHAFT (8) out of universal joint (7).

5. REMOVE nut (2), washer (3), and steering WHEEL (4).

6. REMOVE steering SHAFT (8) from bracket (9).

7. REMOVE BEARING (10) from bracket (9).

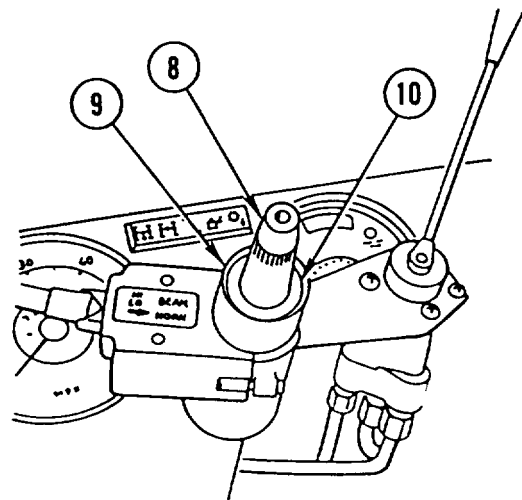
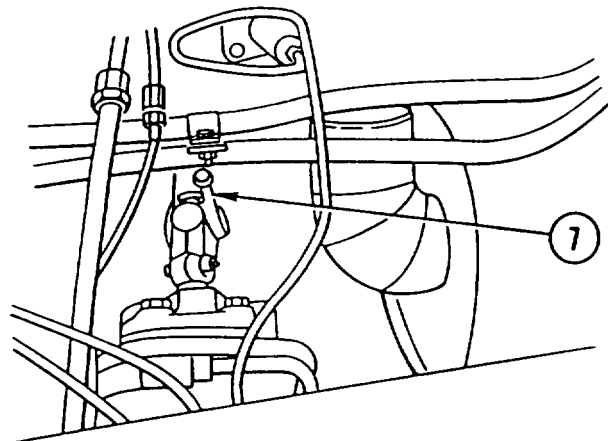

STEERING UPPER SHAFT BEARING REPLACEMENT (CONT)

INSTALLATION

1. INSTALL BEARING (1) in bracket (2).
2. INSTALL steering SHAFT (3) in bracket (2).
3. INSTALL steering WHEEL (4), washer (5), and nut (6) on steering shaft (3). TIGHTEN NUT to 55 lb-ft (75 N.m).
4. BY PUSHING at CENTER of steering WHEEL (4), INSTALL steering SHAFT (3) in universal joint (7) until spline end is completely seated in universal joint (7).
5. INSTALL SCREW (8) and nut (9) on universal joint (7).
6. INSTALL plastic CAP (10) on steering wheel (4).

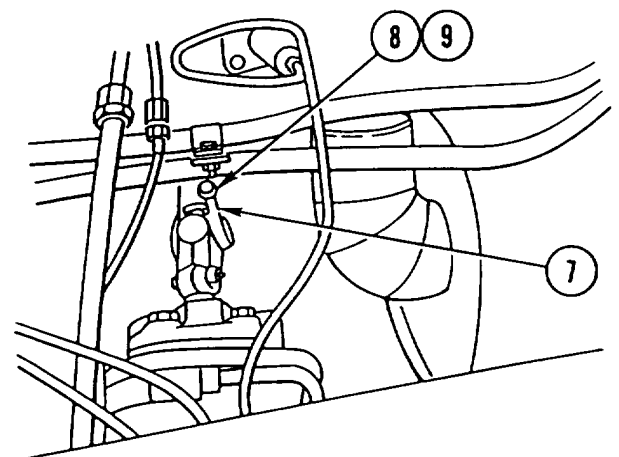
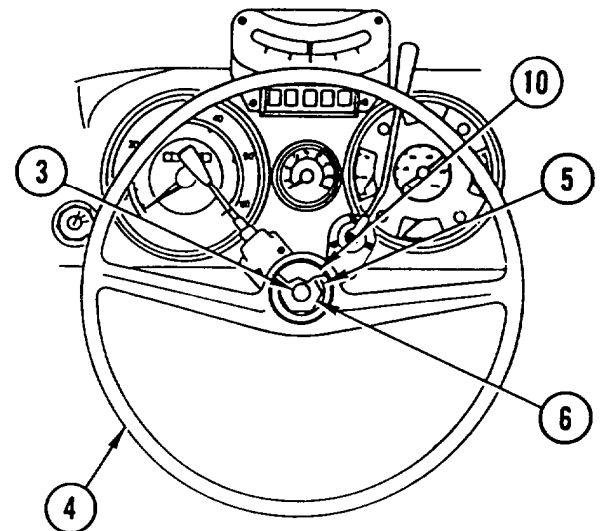
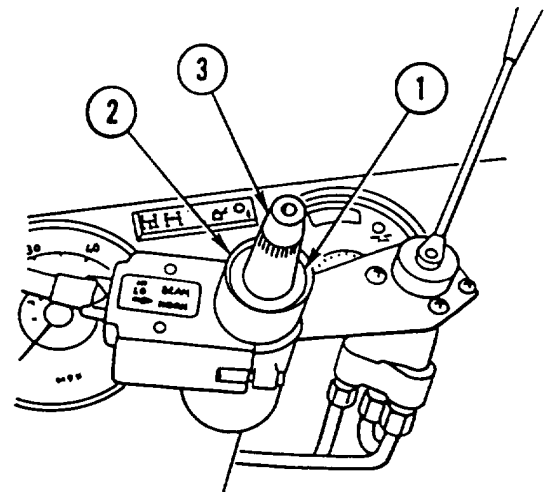

NOTE

Follow-on Maintenance:
Install outside engine hood (page 4-388) .

POWER STEERING GEAR ADJUSTMENT

This task covers: Adjustment

INITIAL SETUP

Tools and Special Equipment:

Tool Kit, SC 5180-90-CL-N26

Personnel Required: (2)

References:

TM 5-2420-224-10

Equipment Condition:

Reference

TM 5-2420-224-10

Condition Description

Vehicle Parked on Level
Ground with Front Wheels
Straight Ahead and
Engine Running

General Safety Instructions:

WARNING

Before adjusting power steering gear, make sure parking brake is applied and transmission is in NEUTRAL. Failure to do so could result in injury to personnel.

ADJUSTMENT

1. Hold adjusting screw (1) and loosen nut (2).
2. Rotate steering wheel left or right until slight amount of resistance is felt.
3. If amount of rotation exceeds 0.75 in. (0.03 mm) beyond center, rotate steering wheel back to center.
4. Turn adjusting screw (1) clockwise 1/4-turn.
5. Repeat steps 1 thru 4 until rotation does not exceed 0.75 in. (0.03 mm).

POWER STEERING GEAR ADJUSTMENT (CONT)

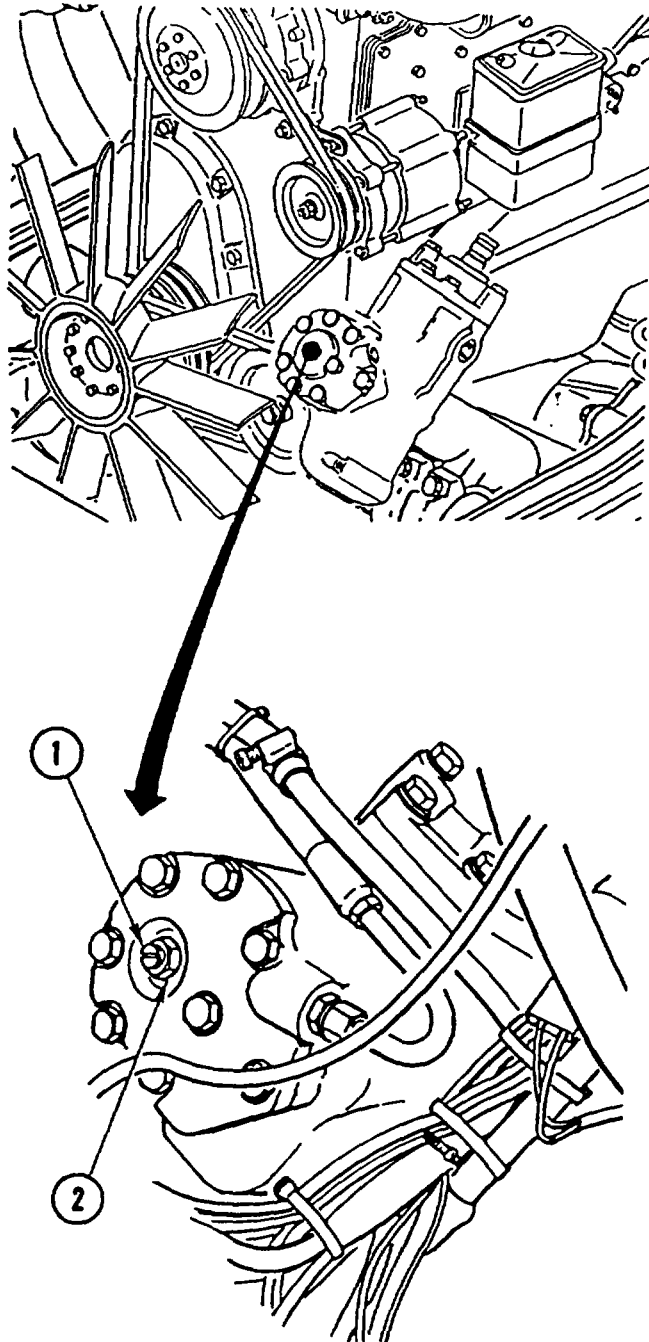

POWER STEERING PUMP BELT REPLACEMENT AND ADJUSTMENT

This task covers: a. Removal b. Installation/Adjustment

INITIAL SETUP

Tools and Special Equipment:

Tool Kit, SC 5180-90-CL-N26

Equipment Condition:

Reference

Page 4-388

Condition Description

Outside Engine Hood
Removed

REMOVAL

1. LOOSEN NUT (1).
2. LOOSEN lock NUT (2) and TURN SCREW (3) to LOOSEN BELT (4).
3. REMOVE BELT (4).

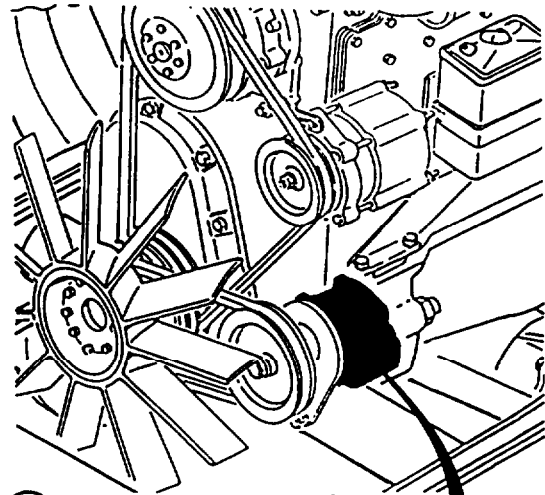

INSTALLATION/ADJUSTMENT

1. INSTALL BELT (4).
2. TURN SCREW (3) to TIGHTEN tension on BELT (4).
3. APPLY THUMB PRESSURE on BELT (4) and continue to TIGHTEN until bow in belt is 0.39-0.59 in. (10-15 mm).
4. TIGHTEN lock NUT (2) and NUT (1).

NOTE

Follow-on Maintenance:
install outside engine hood (page
4-388).

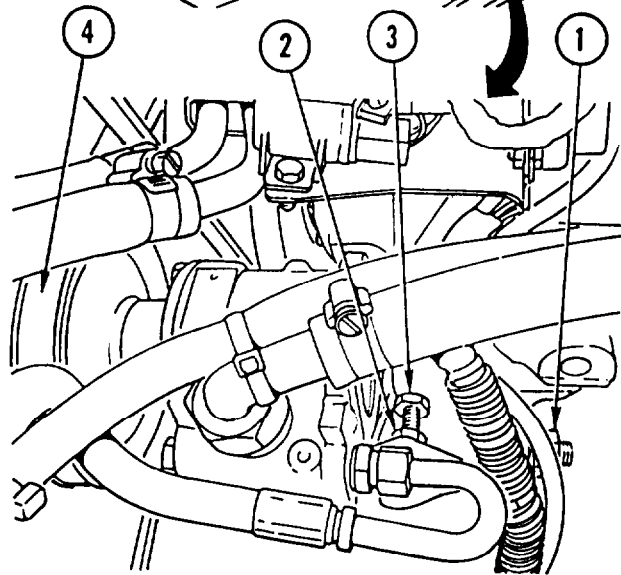

POWER STEERING LINES AND FITTINGS REPLACEMENT

This task covers: a. Removal b. Installation

INITIAL SETUP

Tools and Special Equipment:

Shop Equipment, SC 4910-95-CL-A74
 Tool Kit, SC 5180-90-CL-N26

General Safety Instructions:

WARNING

BURN HAZARD

Allow engine to cool before performing maintenance on the muffler, exhaust pipe, or exhaust manifold. If necessary, use insulated pads and gloves.

Fuel and oil are slippery and can cause falls. To avoid injury, wipe up spilled fuel or oil with rags.

Material/Parts:

Ring, Seal (AR)

Ring, Seal (AR)

Nut, Lock (AR)

Strap (AR)

Rags Appendix C, Item 32

References:

None

Equipment Condition:

Reference	Condition Description
Page 4-418	Cab Tilted
Page 2-14	Power Steering Fluid Drained

REMOVAL

NOTE

Discard seal ring(s), lock nut(s), and strap(s).

REMOVE power steering LINES and FITTINGS using illustration and legend as a guide (page 4-358).

INSTALLATION

NOTE

Install new seal ring(s), lock nut(s), and strap(s).

INSTALL power steering LINES and FITTINGS using illustration and legend as a guide (page 4-358).

NOTE

Follow-on Maintenance:

Fill power steering pump reservoir (page 2-14).
 Lower cab (page 4-418).

POWER STEERING LINES AND FITTINGS REPLACEMENT (CONT)

LEGEND

- 1 Hollow screw
- 2 Seal ring (2)
- 3 Connector
- 4 Screw (2)
- 5 Lock nut (2)
- 6 Clamp
- 7 Clamp
- 8 Nut
- 9 Bracket
- 10 Clamp
- 11 Hose
- 12 Pipe socket
- 13 Strap (2)
- 14 Clamp (2)
- 15 Tube
- 16 Fluid passage bolt
- 17 Seal ring (2)
- 18 Pipe
- 19 Clamp (2)
- 20 Sleeve
- 21 Union nut
- 22 Sleeve
- 23 Fitting
- 24 Tube
- 25 Union nut (2)
- 26 Fitting (2)
- 27 Hose assembly

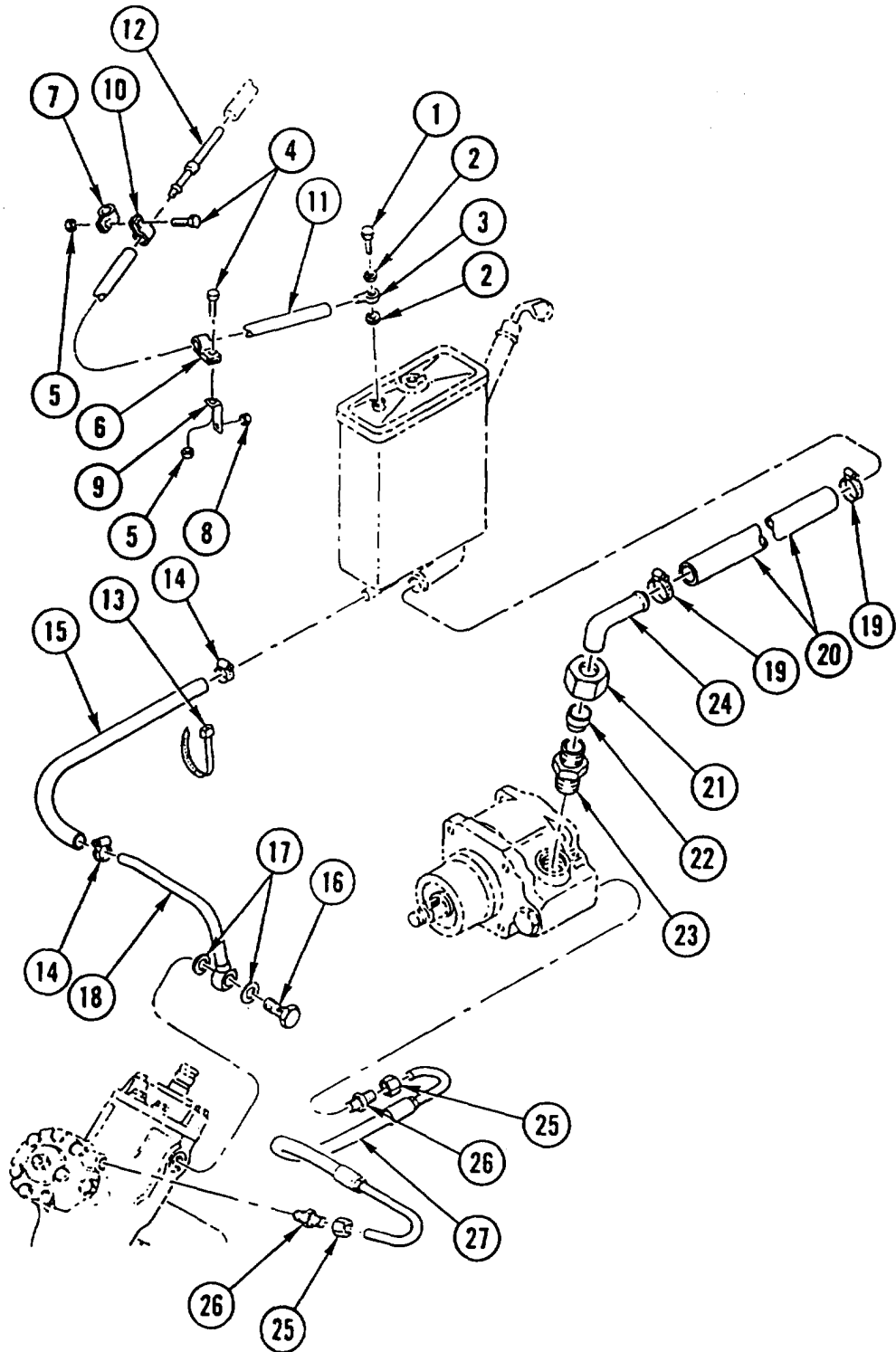

POWER STEERING FILTER ELEMENT REPLACEMENT

This task covers: a. Removal b. Installation

INITIAL SETUP

Tools and Special Equipment:

Tool Kit, SC 5180-90-CL-N26

Materials/Parts:

Gasket

Element, Filter

Rags Appendix C, Item 32

References:

None

Equipment Condition:

Reference	Condition Description
Page 4-418	Cab Tilted

General Safety Instructions:

WARNING

- **BURN HAZARD**
Allow engine to cool before performing maintenance on the muffler, exhaust pipe, or exhaust manifold. If necessary, use insulated pads and gloves.
- Fuel and oil are slippery and can cause falls. To avoid injury, wipe up spilled fuel or oil with rags.

REMOVAL

1. LOOSEN wing NUT (1) and REMOVE tank COVER (2) and gasket (3). DISCARD GASKET.
2. REMOVE and DISCARD filter ELEMENT (4).

INSTALLATION

1. INSTALL new filter ELEMENT (4).
2. INSTALL new GASKET (3) and tank COVER (2).
3. TIGHTEN wing NUT (1).

NOTE

Follow-on Maintenance:
Lower cab (page 4-418).
Check power steering fluid level
(page 2-14).

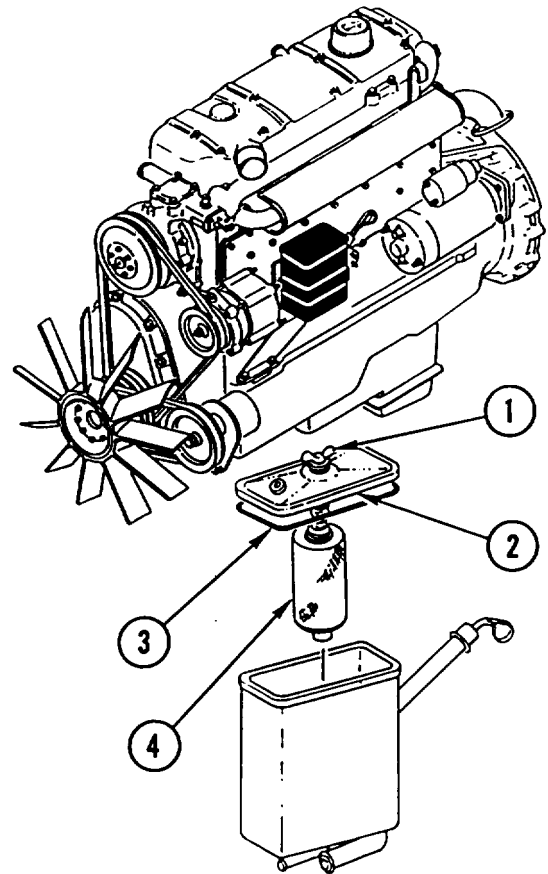

POWER STEERING TANK (RESERVOIR) REPLACEMENT

This task covers: a. Removal b. Installation

INITIAL SETUP

Tools and Special Equipment:

Shop Equipment, SC 4910-95-CL-A74
Tool Kit, SC 5180-90-CL-N26

Materials/Parts:

Ring, Seal (2)

Ring, Seal

Gasket

Element, Filter

Packing

Packing

Rags

Appendix C, Item 32

References:

None

Equipment Condition:

Reference	Condition	Description
Page 4-418	Cab Tilted	

General Safety Instructions:

WARNING

Fuel and oil are slippery and can cause falls. To avoid injury, wipe up spilled fuel or oil with rags.

REMOVAL

1. LOOSEN hose CLAMP (1), DISCONNECT SLEEVE (2) from tube assembly (3), and DRAIN power steering FLUID from power steering tank (4) into suitable container.

NOTE

Tag all lines prior to disconnecting to aid in connecting.

2. REMOVE hollow SCREW (5) and two seal rings (6) and Disconnect HOSE (7). DISCARD seal RINGS.
3. LOOSEN CLAMP (8) and DISCONNECT TUBING (9).
4. LOOSEN CLAMP (10) and REMOVE SLEEVE (2).

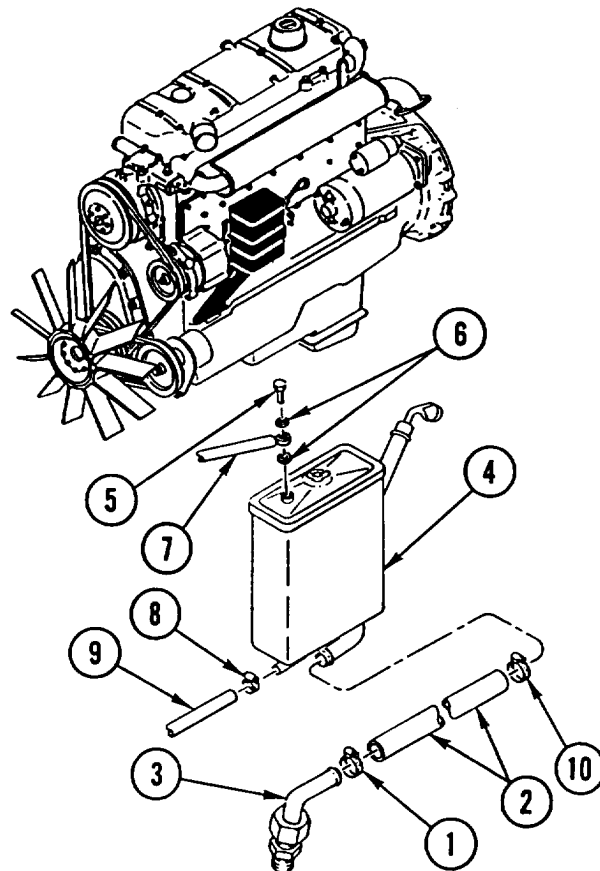

POWER STEERING TANK (RESERVOIR) REPLACEMENT (CONT)

5. REMOVE two capscrews (11) and power steering TANK (4).
6. REMOVE two nuts (12), clamp (13), and BRACKET (14).
7. REMOVE roll pin (15), wing nut (16), washer (17), seal ring (18), spring (19), and STUD (20) from cover (21). DISCARD seal RING.
8. REMOVE and DISCARD GASKET (22).
9. REMOVE and DISCARD filter ELEMENT (23)..
10. REMOVE ROD (24), packing (25), and packing (26). DISCARD PACKINGS.

INSTALLATION

1. INSTALL new packing (26), new packing (25), and ROD (24).
2. INSTALL new filter ELEMENT (23).
3. INSTALL new GASKET (22).
4. INSTALL STUD (20), spring (19), new seal ring (18), washer (17), wing-nut (16), and roll pin (15) in cover (21).
5. INSTALL BRACKET (14), clamp (13), and two nuts (12).
6. INSTALL power steering TANK (4) and two capscrews (11).
7. INSTALL SLEEVE (2) and TIGHTEN CLAMP (10).
8. CONNECT TUBING (9) and TIGHTEN CLAMP (8).
9. CONNECT HOSE (7) and INSTALL two new seal rings (6) and hollow SCREW (5).
10. CONNECT SLEEVE (2) to tube assembly (3) and TIGHTEN hose CLAMP (1).

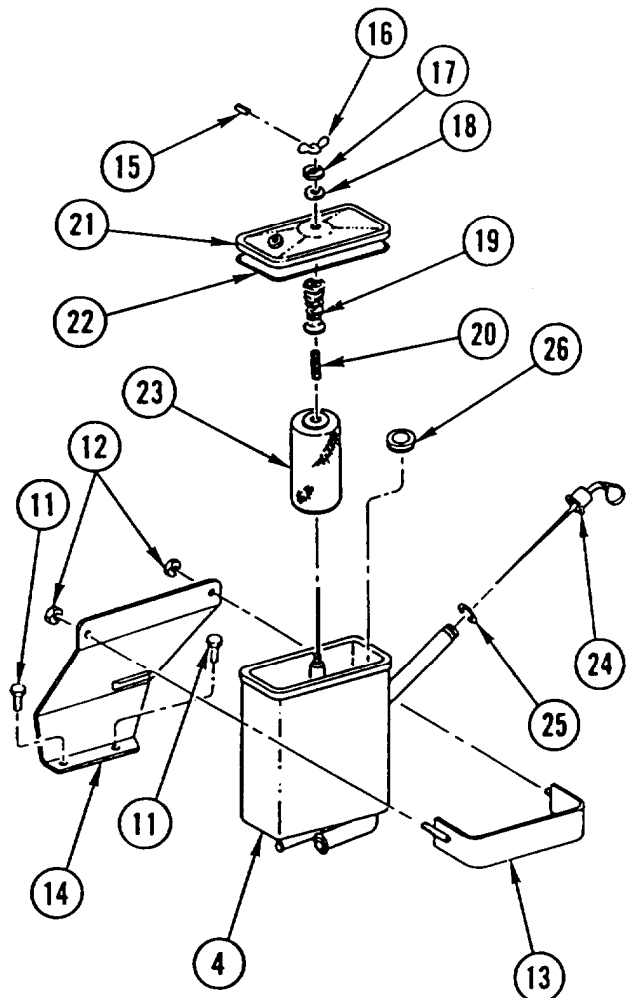
NOTE

Follow-on Maintenance:

Fill power steering tank (reservoir)
(page 2-14).
Lower cab (page 4-418).

Section XII. FRAME AND TOWING ATTACHMENTS MAINTENANCE

OVERVIEW

This section illustrates and describes procedures for maintenance of the frame and towing attachments and related parts. A list of tasks contained in this section is shown below.

	Page
Backhoe Subframe Deck Replacement	4-362
Decontamination Mounting Bracket Replacement	4-363
Chassis Tool Box/Deck Plate Replacement	4-364
Pintle Assembly Replacement	4-365

BACKHOE SUBFRAME DECK REPLACEMENT

This task covers: a. Removal b. Installation

INITIAL SETUP

Applicable Configuration:

SEE

Equipment Condition:

Reference

Condition Description

Tools and Special Equipment:

Tool Kit, SC 5180-90-CL-N26

Page 2-22

Backhoe in Three-Point Stance

REMOVAL

REMOVE four screws (1) and backhoe subframe DECK (2).

INSTALLATION

INSTALL backhoe subframe DECK (2) and four screws (1).

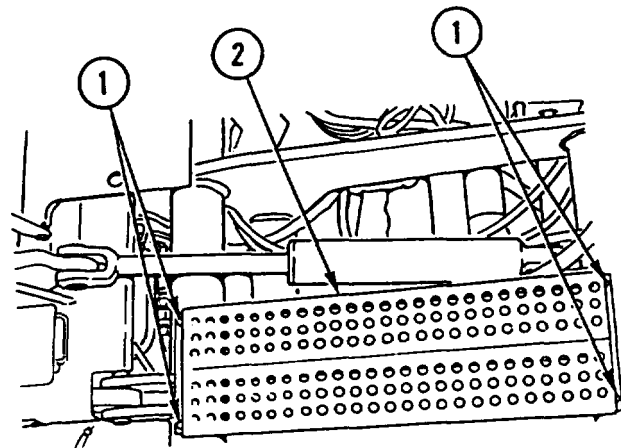

DECONTAMINATION MOUNTING BRACKET REPLACEMENT

This task covers: a. Removal b. installation

INITIAL SETUP

Tools and Special Equipment:

Tool Kit, SC 5180-90-CL-N26

REMOVAL

1. REMOVE SCREW (1), washer (2), and nut (3).
2. REMOVE four nuts (4), four screws (5), and decontamination mounting BRACKET (6).

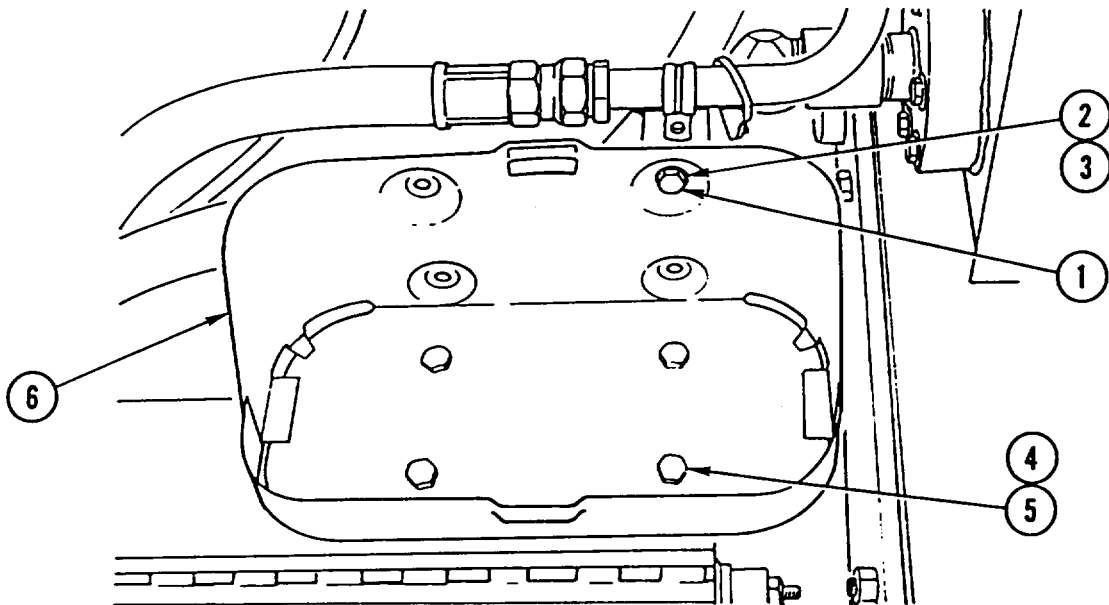

INSTALLATION

1. INSTALL decontamination mounting BRACKET (6), four screws (5), and four nuts (4),
2. INSTALL washer (2), SCREW (1), and nut (3).

CHASSIS TOOL BOX/DECK PLATE REPLACEMENT

This task covers: a. Removal b. Installation

INITIAL SETUP

Tools and Special Equipment:

Tool Kit, SC 5180-90-CL-N26

Materials/Parts:

Nut, Lock (4)

Equipment Condition:

Reference

Condition Description

Page 4-363

REMOVAL

NOTE

Vehicles with serial No. 451550 and above will have deck plate.

REMOVE four screws (1), four lock nuts (2), and chassis tool BOX/DECK PLATE (3). DISCARD lock NUTS.

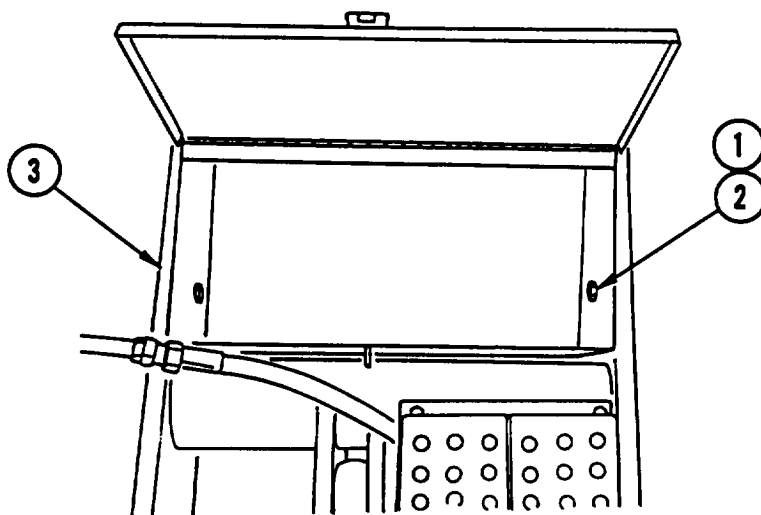

INSTALLATION

NOTE

Vehicles with serial No. 451550 and above will have deck plate.

INSTALL chassis tool BOW/DECK PLATE (3), four screws (1), and four new lock nuts (2).

NOTE

Follow-on Maintenance:

Install decontamination mounting bracket (page 4-363).

PINTLE ASSEMBLY REPLACEMENT

This task covers: a. Removal b. Disassembly c. Inspection d. Assembly e. Installation

INITIAL SETUP

Tools and Special Equipment:

Shop Equipment, SC 4910-95-CL-A74
Tool Kit, SC 5180-90-CL-N26

Materials/Parts:

Pin, Cotter (3)

REMOVAL

REMOVE cotter pin (1), nut (2), spacer (3), and PINTLE assembly (4). DISCARD cotter PIN.

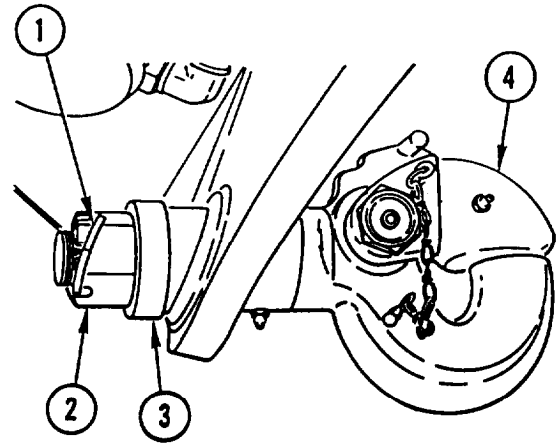

DISASSEMBLY

1. REMOVE two fittings (1), two cotter pins (2 and 3), nut (4), bolt (5), and LATCH (6). DISCARD cotter PINS.
2. REMOVE screw and hook CHAIN (7) from hook (8).

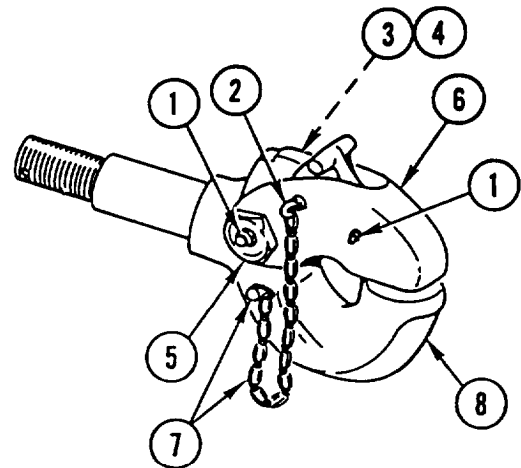

INSPECTION

1. Inspect latch and hook for cracks.
2. Inspect bolt and hook for damaged threads.

PINTLE ASSEMBLY REPLACEMENT (CONT)

ASSEMBLY

1. INSTALL screw and hook CHAIN (1) on hook (2).
2. INSTALL LATCH (3), bolt (4), nut (5), two new cotter pins (6 and 7), and two fittings (8).

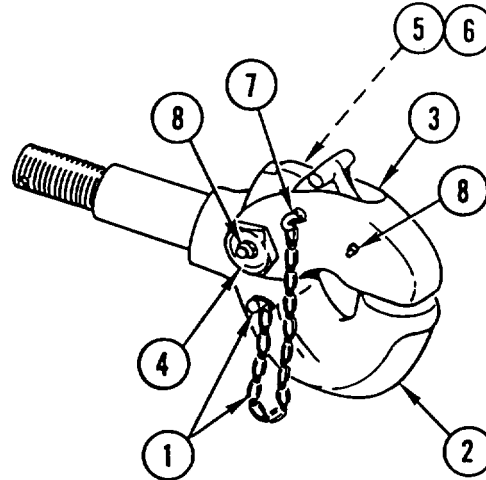

INSTALLATION

1. INSTALL PINTLE assembly (1), spacer (2), and nut (3).
2. TIGHTEN NUT (3) until pintle assembly (1) stops rotating freely. BACK OFF NUT (3) until first slot in nut (3) aligns with hole in pintle assembly (1).
3. INSTALL new cotter PIN (4).

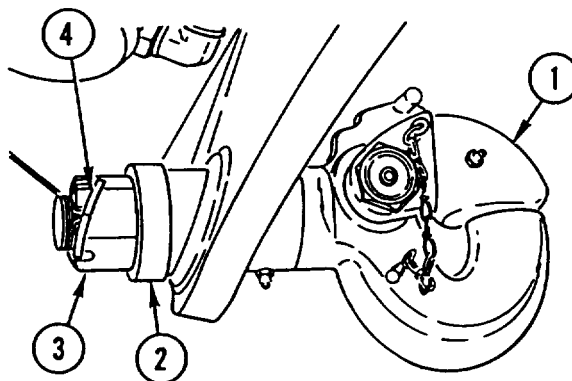

Section XIII. SPRINGS AND SHOCK ABSORBERS MAINTENANCE

OVERVIEW

This section illustrates and describes procedures for maintenance of the springs and shock absorbers and related parts. A list of tasks contained in this section is shown below.

	Page
Front Rubber Bumpers Replacement	4-367
Front Shock Absorbers Replacement	4-368
Front Shock Absorbers Replacement	4-369
Rear Shock Absorbers Replacement	4-372
Front Control Arm Replacement	4-374
Rear Control Arm Replacement	4-375
Front Axle Torsion Bar Replacement	4-376
Rear Axle Torsion Bar Replacement	4-378

FRONT RUBBER BUMPERS REPLACEMENT

This task covers: a. Removal b. Installation

INITIAL SETUP

Tools and Special Equipment:

Shop Equipment, SC 4910-95-CL-A74
 Tool Kit, SC 5180-90-CL-N26

REMOVAL

NOTE

Procedure is the same for both sides of vehicle.

REMOVE two nuts (1) and rubber BUMPER (2).

INSTALLATION

NOTE

Procedure is the same for both sides of vehicle.

INSTALL rubber BUMPER (2) and two nuts (1).

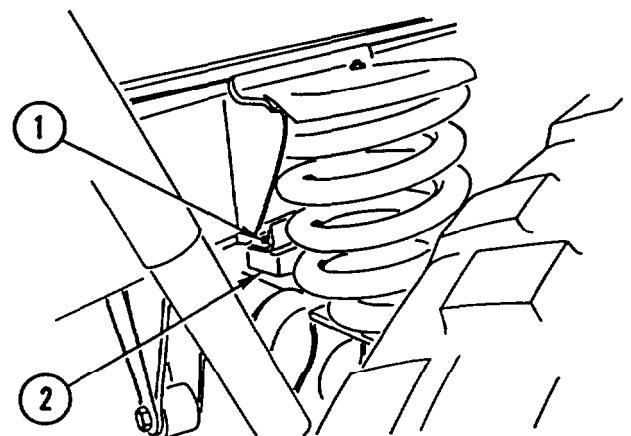

FRONT SHOCK ABSORBERS REPLACEMENT

This task covers: a. Removal b. Installation

INITIAL SETUP

Applicable Configuration:

SEE

Tools and Special Equipment:

Shop Equipment, SC 4910-95-CL-A74
 Tool Kit, SC 5180-90-CL-N26

Materials/Parts:

Washer, Lock (2)

Equipment Condition:

Reference

Page 4-418

Condition Description

Cab Tilted

REMOVAL

NOTE

Procedure is the same for both front shock absorbers.

1. REMOVE two nuts (1 and 2), two lock washers (3 and 4), two screws (5 and 6), and shock ABSORBER (7). DISCARD lock WASHERS.
2. REMOVE two SPACERS (8 and 9) and two BUMPERS (10 and 11).

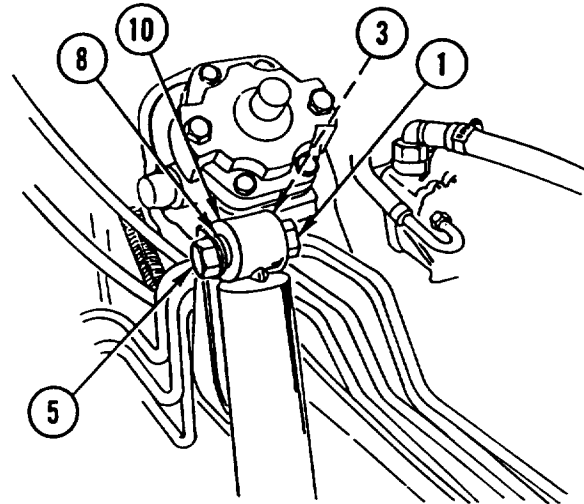

INSTALLATION

NOTE

Procedure is the same for both front shock absorbers.

1. INSTALL two BUMPERS (10 and 11) and two SPACERS (8 and 9).
2. INSTALL shock ABSORBER (7), two screws (5 and 6), two new lock washers (3 and 4), and two nuts (1 and 2). TIGHTEN SCREWS to 177 Ib-ft (240 N.m).

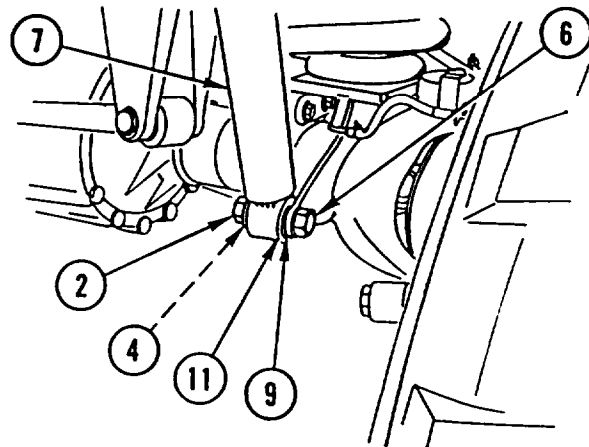

NOTE

Follow-on Maintenance:
 Lower cab (page 4-41 8).

FRONT SHOCK ABSORBERS REPLACEMENT

This task covers: a. Removal b. Installation

INITIAL SETUP

Applicable Configuration:

HMMH

Tools and Special Equipment:

Shop Equipment, SC 4910-95-CL-A74

Tool Kit, SC 5180-90-CL-N26

Materials/Parts:

Ring, Seal (2)

Caps and Plugs Appendix C, Item 7

Rags Appendix C, Item 32

References:

TM 5-2420-224-10

Equipment Condition:

Reference	Condition Description
TM 5-2420-224-10	Suspension Lockout System Disengaged

General Safety Instructions:

WARNING

High pressure hydraulics [oil under 2450 psi (16,893 kPa)] operate this equipment. Never disconnect any hydraulic line or fitting without first dropping pressure to zero. A high pressure oil stream can pierce body and cause severe injury to personnel.

Fuel and oil are slippery and can cause falls. To avoid injury, wipe up spilled fuel or oil with rags.

REMOVAL

CAUTION

Cap or plug all ports and ends of hoses and tubes to prevent contamination of hydraulic oil. Failure to do so may result in damage to equipment.

NOTE

. Procedure is the same for both front shock absorbers.

- Tag lines prior to disconnecting to aid in connecting.

1. DISCONNECT two hydraulic HOSES (1 and 2). INSTALL CAPS or PLUGS.
2. REMOVE two nuts (3), two bolts (4), and front shock ABSORBER (5).
3. REMOVE two BUMPERS (6).

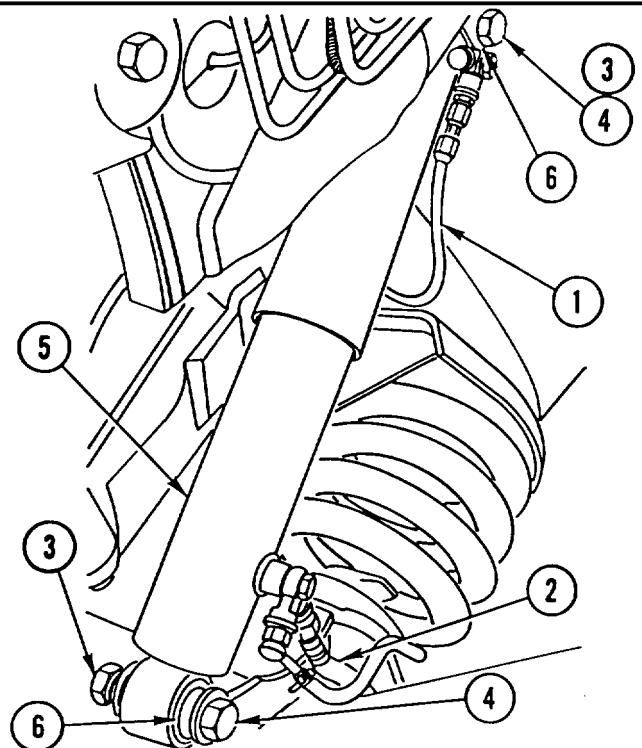

FRONT SHOCK ABSORBERS REPLACEMENT (CONT)

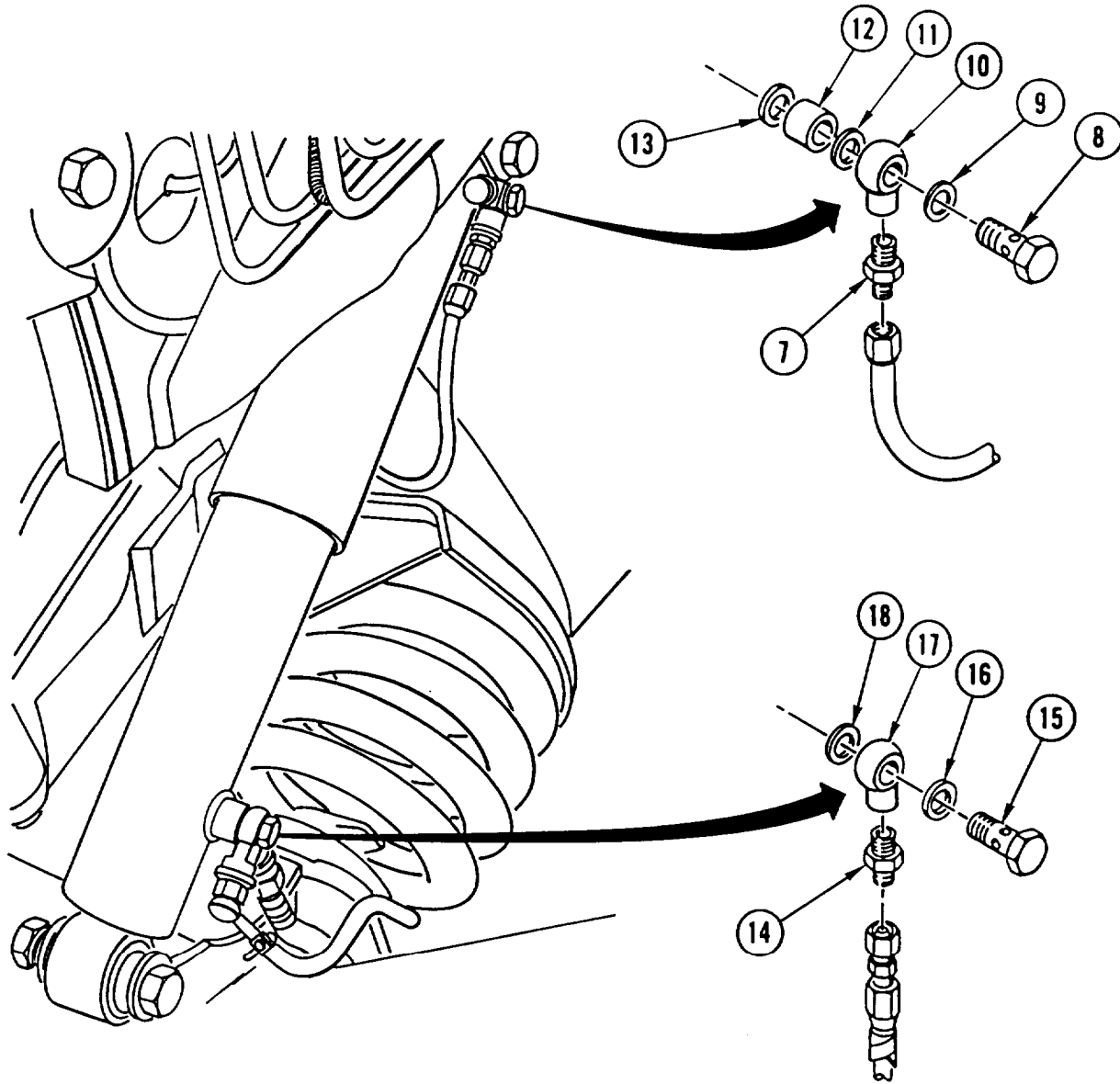

4. REMOVE CONNECTOR (7).
5. REMOVE hollow SCREW (8), seal ring (9), banjo FITTING (10), washer (11), spacer, and washer (13). DISCARD seal RING.
6. REMOVE CONNECTOR (14).
7. REMOVE hollow SCREW (15), seal ring (16), banjo FITTING (17), and washer (18). DISCARD seal RING.

FRONT SHOCK ABSORBERS REPLACEMENT (CONT)

INSTALLATION

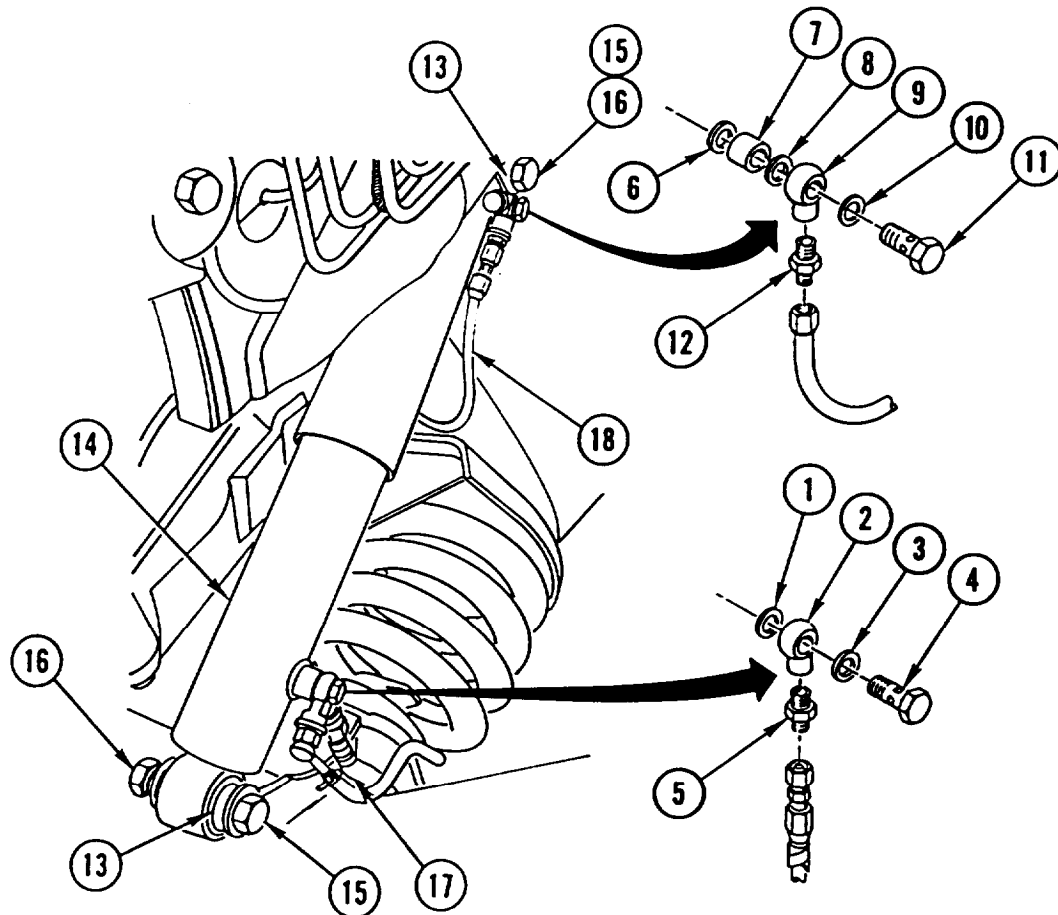
**NOTE**

Procedure is the same for both front shock absorbers.

1. INSTALL washer (1), banjo FITTING (2), new seal ring (3), and hollow SCREW (4).
2. INSTALL CONNECTOR (5).
3. INSTALL washer (6), spacer (7), washer (8), banjo FITTING (9), new seal ring (10), and hollow SCREW (11).
4. INSTALL CONNECTOR (12).
5. INSTALL two BUMPERS (13).
6. INSTALL front shock ABSORBER (14), two bolts (15), and two nuts (16). TIGHTEN BOLTS to 177 lb-ft (240 N.m).
7. REMOVE CAPS or PLUGS. CONNECT two hydraulic HOSES (17 and 18).

NOTE

Follow-on Maintenance:

Check suspension lockout oil level (page 2-14).

REAR SHOCK ABSORBERS REPLACEMENT

This task covers: a. Removal b. Installation

INITIAL SETUP

Tools and Special Equipment:

Shop Equipment, SC 4910-95-CL-A74
Tool Kit, SC 5180-90-CL-N26

Materials/Parts:

Washer, Lock
Nut, Lock

REMOVAL

NOTE

Procedure is the same for both rear shock absorbers.

1. REMOVE nut (1), lock washer (2), screw (3), and two SPACERS (4). DISCARD lock WASHER.
2. REMOVE lock nut (5), washer (6), screw (7), and rear shock ABSORBER (8). DISCARD lock NUT.
3. REMOVE two spacer SLEEVES (9) and two BUMPERS (10).

INSTALLATION

NOTE

Procedure is the same for both rear shock absorbers.

1. INSTALL two BUMPERS (10) and two spacer SLEEVES (9).
2. INSTALL rear shock ABSORBER (8), screw (7), washer (6), and new lock nut (5). TIGHTEN SCREW to 177 lb-ft (240 N.m).
3. INSTALL two SPACERS (4), screw (3), new lock washer (2), and nut (1).

REAR SHOCK ABSORBERS REPLACEMENT (CONT)

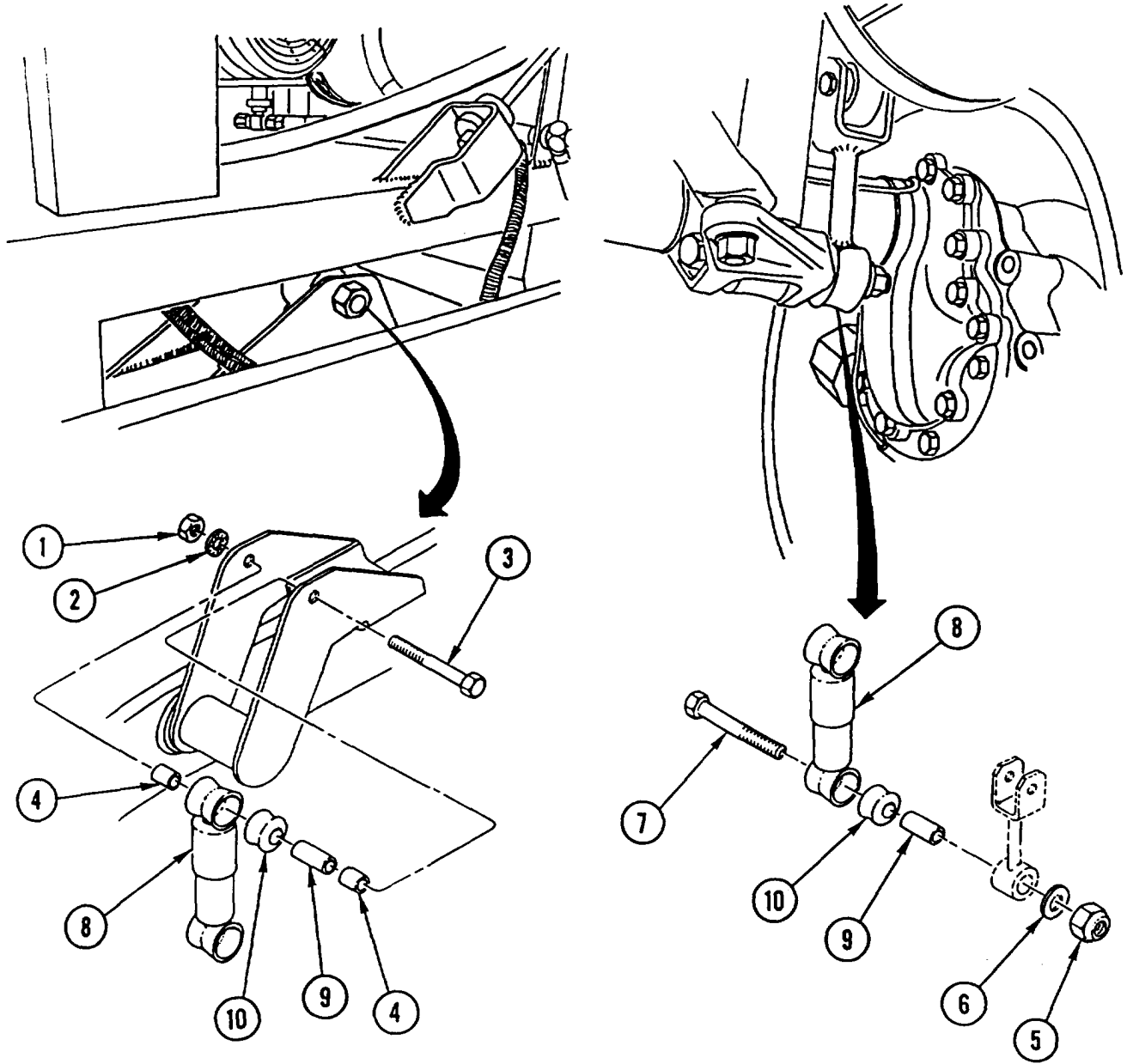

FRONT CONTROL ARM REPLACEMENT

This task covers: a. Removal b. Installation

INITIAL SETUP

Tools and Special Equipment:

Shop Equipment, SC 4910-95-CL-A74
 Tool Kit, SC 5180-90-CL-N26

Materials/Parts:

Nut, Lock
 Screw, Lock
 Washer, Lock

Equipment Condition:

Reference	Condition Description
Page 2-22	Vehicle Blocked

General Safety Instructions:

WARNING

Support control arm during removal. Failure to do so could result in injury to personnel.

REMOVAL

1. REMOVE lock nut (1), screw (2), lock screw (3), lock washer (4), and control ARM (5). DISCARD lock NUT, lock SCREW, and lock WASHER.
2. REMOVE two BUSHINGS (6 and 7) and two MOUNTS (8) from control arm (5).

INSTALLATION

1. INSTALL two MOUNTS (8) and two BUSHINGS (6 and 7) in control arm (5).
2. INSTALL control ARM (5), new lock washer (4), screw (2), new lock screw (3), and new lock nut (1). TIGHTEN SCREW to 133 lb-ft (180 N•m).

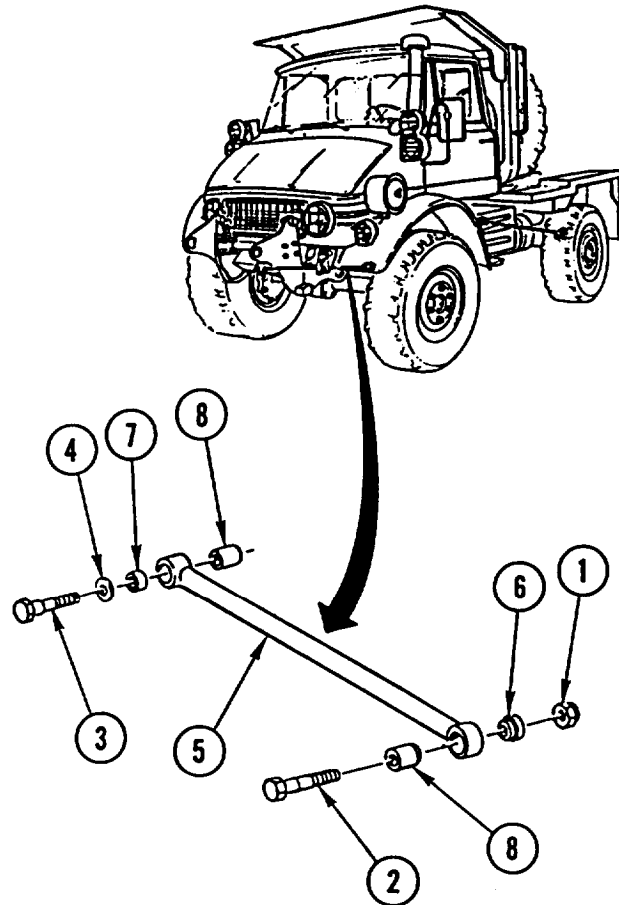

REAR CONTROL ARM REPLACEMENT

This task covers: a. Removal b. Installation

INITIAL SETUP

Tools and Special Equipment:

Shop Equipment, SC 4910-95-CL-A74
Tool Kit, SC 5180-90-CL-N26

Materials/Parts:

Nut, Lock
Screw, Lock
Washer, Lock

Equipment Condition:

Reference	Condition Description
Page 2-22	Vehicle Blocked

General Safety Instructions:

WARNING

Support control arm during removal. Failure to do so could result in injury to personnel.

REMOVAL

1. REMOVE lock nut (1), lock screw (2), screw (3), lock washer (4), and control ARM (5). DISCARD lock NUT, lock SCREW, and lock WASHER.
2. REMOVE two BUSHINGS (6 and 7) and two MOUNTS (8) from control arm (5).

INSTALLATION

1. INSTALL two MOUNTS (8) and two BUSHINGS (6 and 7) in control arm (5).
2. INSTALL control ARM (5), new lock washer (4), screw (3), new lock screw (2), and new lock nut (1). TIGHTEN SCREW to 133 lb-ft (180 N•m).

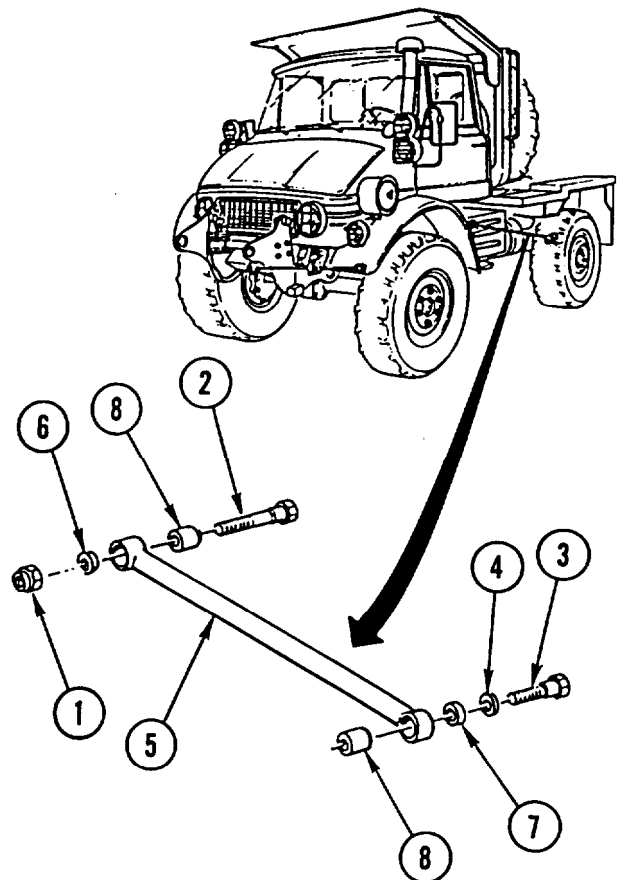

FRONT AXLE TORSION BAR REPLACEMENT

This task covers: a. Removal b. Installation

INITIAL SETUP

Tools and Special Equipment:

Shop Equipment, SC 4910-95-CL-A74
Tool Kit, SC 5180-90-CL-N26

Equipment Condition:

Reference

Page 4-418

Condition Description

Cab Tilted

Materials/Parts:

Nut, Lock (2)

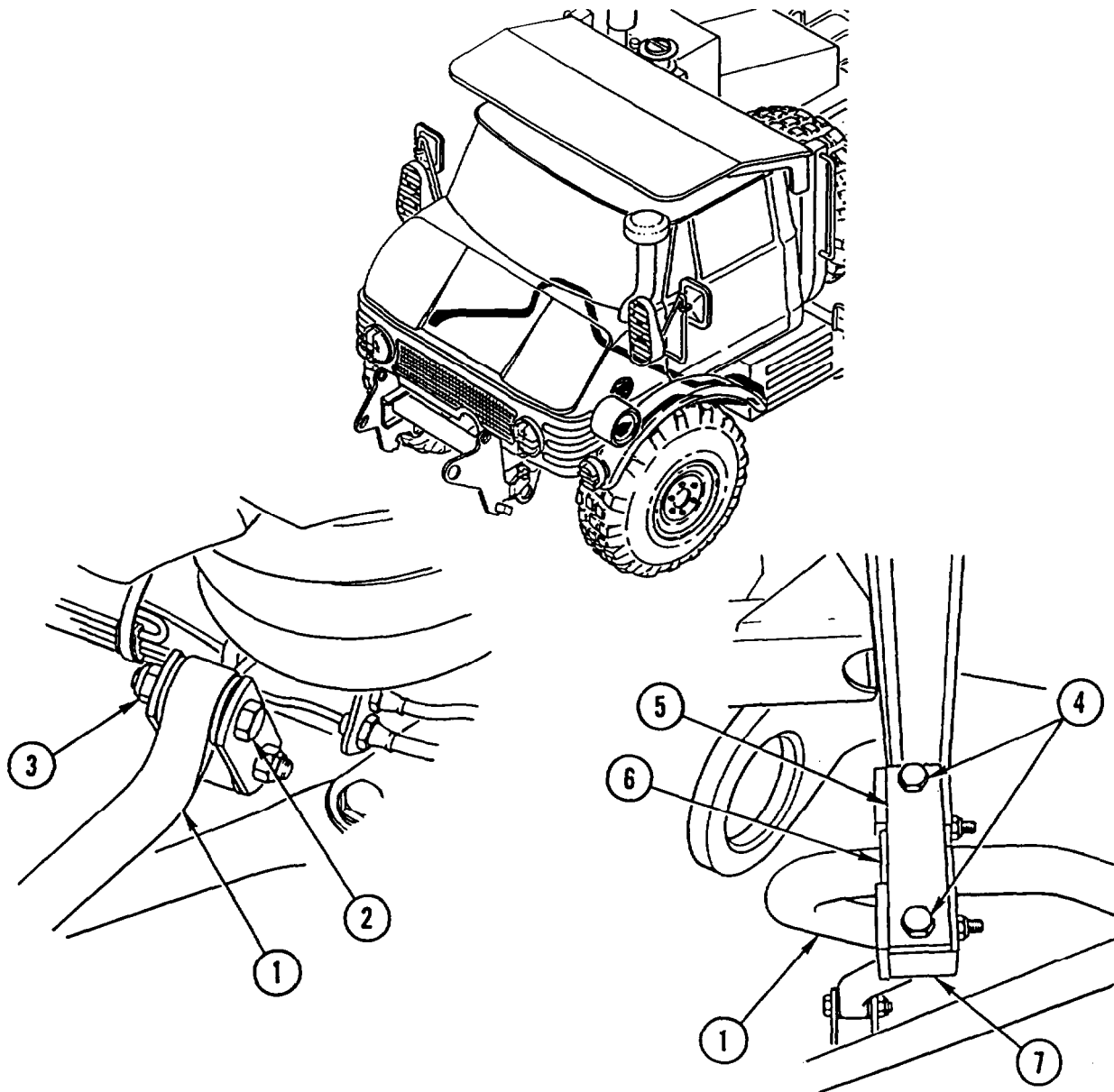

FRONT AXLE TORSION BAR REPLACEMENT (CONT)

REMOVAL

1. RAISE FRONT of vehicle SUFFICIENTLY to relieve tension from torsion bar (1).
2. REMOVE SCREW (2) and lock nut (3). DISCARD lock NUT.
3. REMOVE two screws (4) and PLATE (5).
4. REPEAT STEPS 2 and 3 for other side of vehicle.
5. REMOVE front axle torsion BAR (1).
6. IF DAMAGED, REMOVE BEARING (6) and CARRIER (7) from each side of vehicle.

INSTALLATION

1. IF REMOVED, INSTALL new CARRIER (7) and new BEARING (6) on each side of vehicle.
2. INSTALL front axle torsion BAR (1).
3. INSTALL PLATE (5) and two screws (4).
4. INSTALL SCREW (2) and new lock nut (3). TIGHTEN SCREW to 199 lb-ft (270 N•m).
5. REPEAT STEPS 3 and 4 for other side of vehicle.
6. LOWER VEHICLE.

NOTE

Follow-on Maintenance:

Lower cab (page 4-418).

REAR AXLE TORSION BAR REPLACEMENT

This task covers: a. Removal b. Installation

INITIAL SETUP

Tools and Special Equipment:

Shop Equipment, SC 4910-95-CL-A74
Tool Kit, SC 5180-90-CL-N26

Materials/Parts:

Nut, Lock (2)
Nut, Lock (2)
Pin, Cotter (2)

Personnel Required: (2)

References:

None

Equipment Condition:

Reference

Page 4-335

Condition Description

Rear Wheel Assemblies
Removed

General Safety Instructions:

WARNING

- Make sure rear axle is properly supported with jack stands. Failure to do so could result in serious injury to personnel.

REMOVAL

NOTE

Procedure is the same for both sides except as noted.

1. REMOVE lock NUT (1) and BACK out SCREW (2) far enough to RELEASE connecting LINK (3) from shock mount (4). DISCARD lock NUT.
2. REMOVE lock nut (5), screw (6), and connecting LINK (3). DISCARD lock NUT.

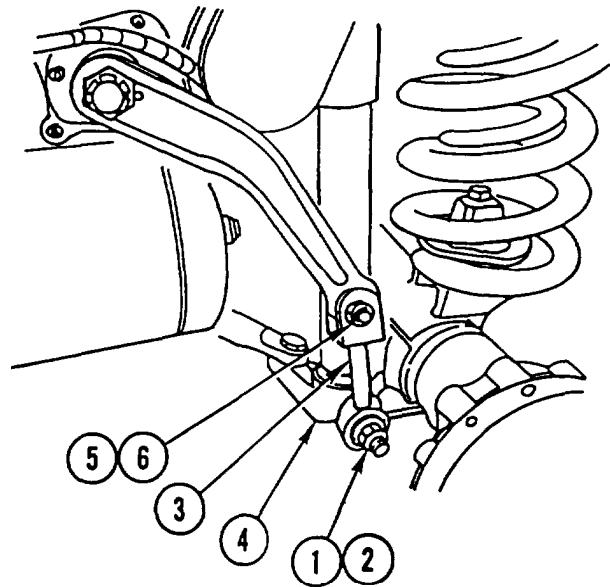

REAR AXLE TORSION BAR REPLACEMENT (CONT)

3. REMOVE cotter pin (7) and castellated NUT (8). DISCARD cotter PIN.
4. USING suitable PULLER, REMOVE LEVER (9).
5. ON LEFT SIDE, REMOVE three washers (10) and BUSHING (11).

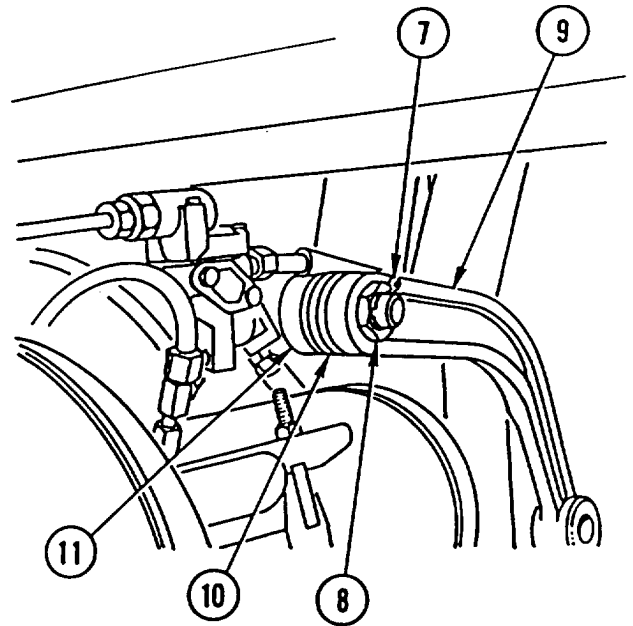

6. ON RIGHT SIDE, REMOVE washer (12) and BUSHING (13).
7. REMOVE four lock nuts (14), four screws (15), and two SPACERS (16).

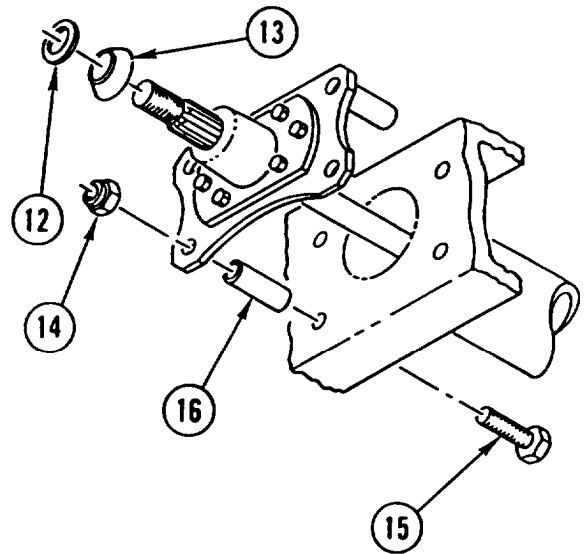

FEAR AXLE TORSION BAR REPLACEMENT (CONT)

8. ON RIGHT SIDE, LOOSEN NUT (17), DISCONNECT PIPE (18), and DRAIN ANTIFREEZE into safety can.
9. ON RIGHT SIDE, REMOVE two nuts (19), two screws (20), and BRACKET (21) from antifreeze device (22).

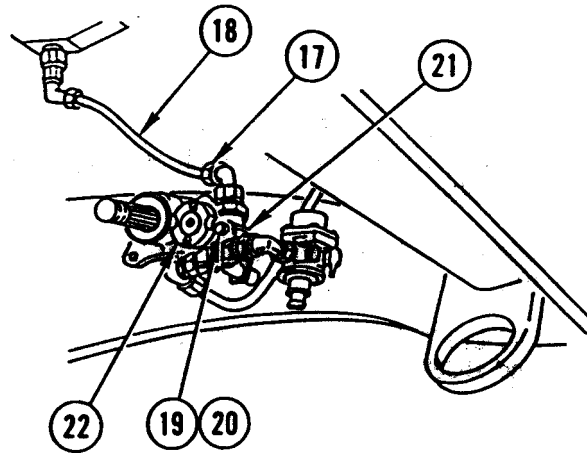

10. REMOVE PLATE (23).
11. REMOVE rear axle torsion BAR (24).

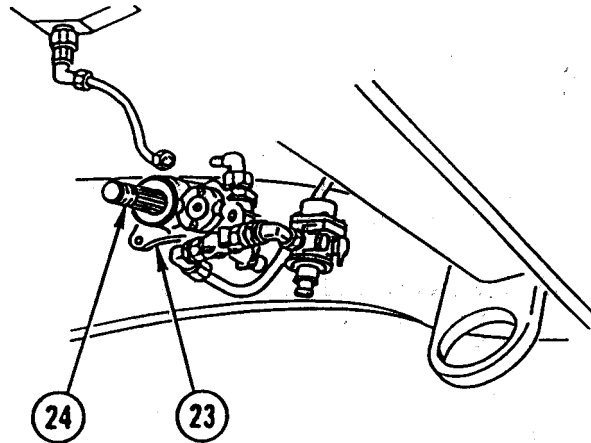

12. REMOVE six nuts (25), six screws (26), HOUSING (27), and bumper (28) from plate (23).

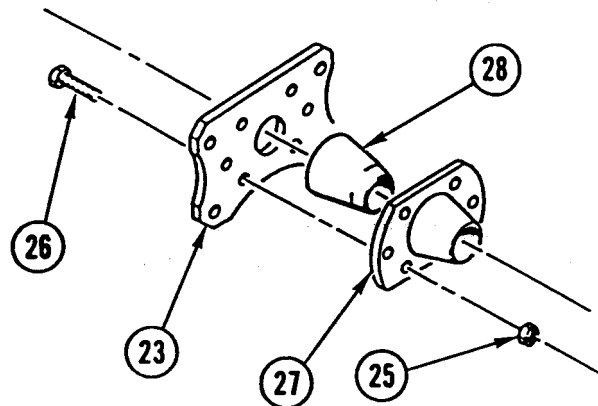

REAR AXLE TORSION BAR REPLACEMENT (CONT)

13. IF DAMAGED, REMOVE BUMPER (29) from connecting link (3) and BUMPER (30) from lever (9).

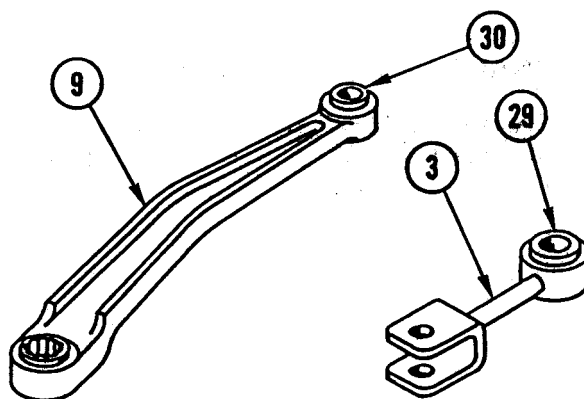

INSTALLATION

NOTE

Procedure is the same for both sides, except as noted.

1. IF REMOVED, INSTALL new BUMPER (1) in connecting fink (2) and new BUMPER (3) in lever (4).

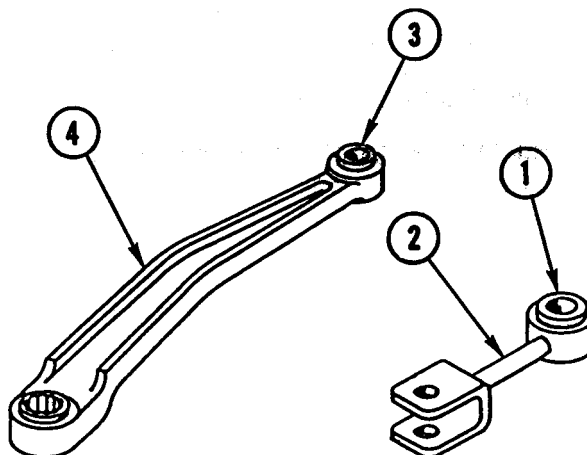

2. INSTALL bumper (5), HOUSING (6), six screws (7), and six nuts (8) in plate (9).

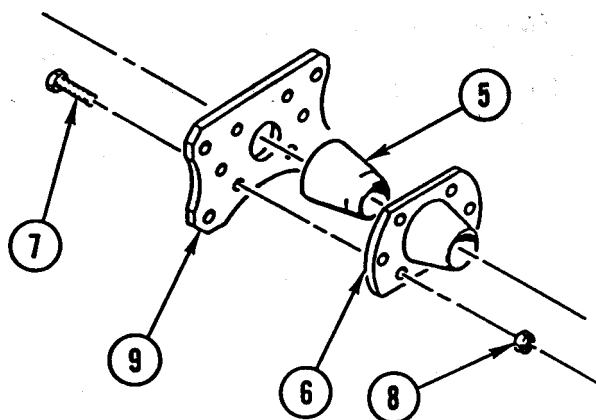

REAR AXLE TORSION BAR REPLACEMENT (CONT)

3. INSTALL rear axle torsion BAR (10).
4. INSTALL PLATE (9).

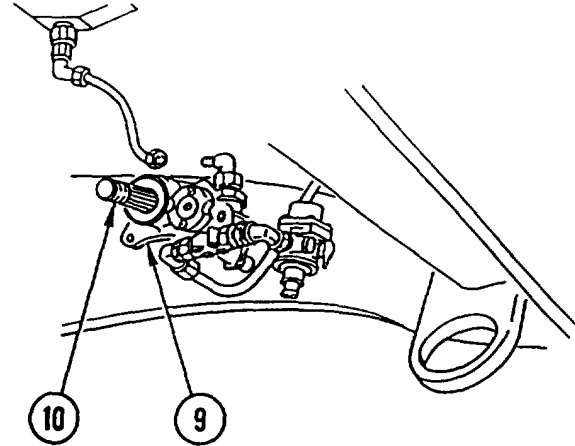

5. ON RIGHT SIDE, INSTALL BRACKET (11), two screws (12), and two nuts (13) on antifreeze device (14).
6. ON RIGHT SIDE, CONNECT PIPE (15) and TIGHTEN NUT (16).

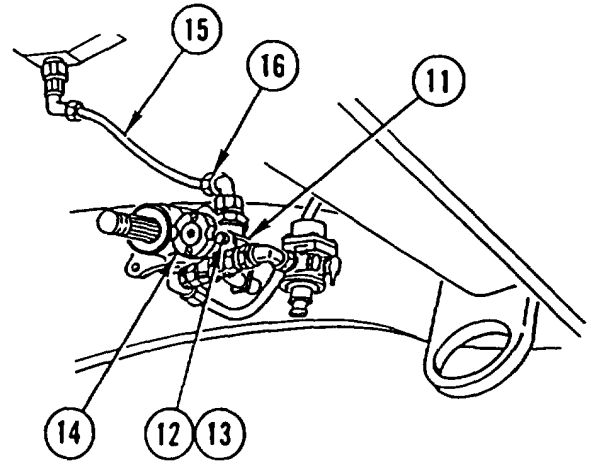

7. INSTALL two SPACERS (17), four screws (18), and four lock nuts (19).
8. ON RIGHT SIDE, INSTALL BUSHING (20) and washer (21).

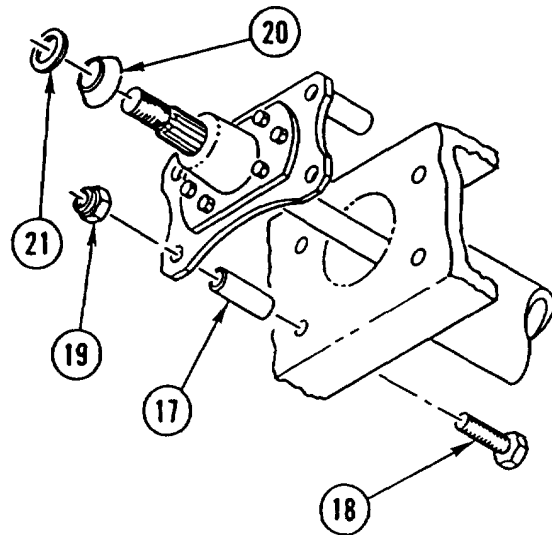

REAR AXLE TORSION BAR REPLACEMENT (CONT)

9. ON LEFT SIDE, INSTALL BUSHING (22) and three washers (23).
10. INSTALL LEVER (4).
11. INSTALL castellated NUT (24) and new cotter pin (25).

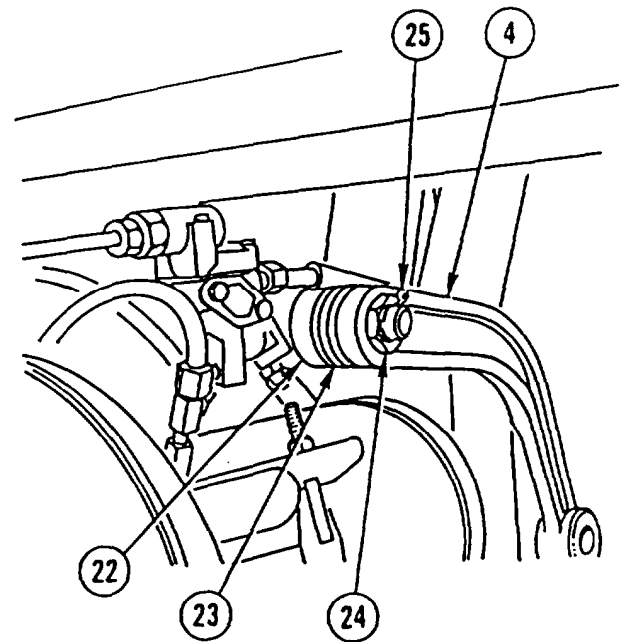

12. INSTALL connecting LINK (2), screw (26), and new lock nut (27).
13. CONNECT connecting LINK (2) to shock mount (28) and THREAD SCREW (29) through connecting link (2) and shock mount (28). INSTALL new lock NUT (30).

NOTE

Follow-on Maintenance:
Fill antifreeze device (page 2-14).

Install rear wheel assemblies
(page 4-335).

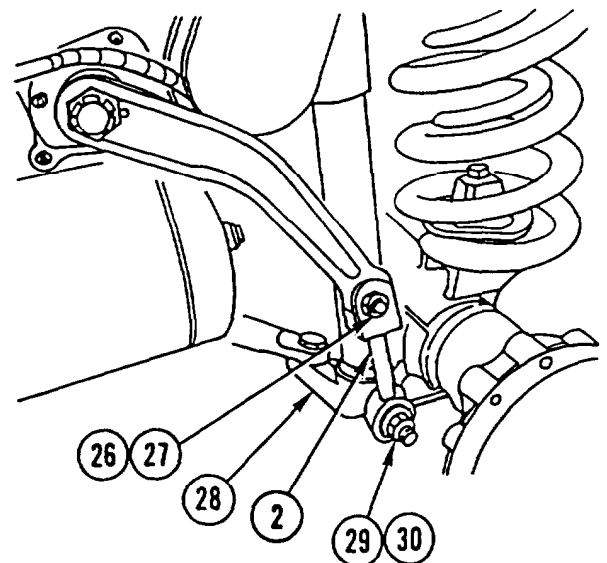

Section XIV. BODY, CAB, AND HOOD MAINTENANCE

OVERVIEW

This section illustrates and describes procedures for maintenance of the body, cab, and hood and related parts. A list of tasks contained in this section is shown below

	Page
Front Plate Replacement	4-385
Canopy (FOPS) Replacement	4-387
Outside Engine Hood Replacement	4-388
Inside Engine Hood Replacement	4-389
Spare Tire and Mount Replacement	4-390
Spare Tire and Mount Replacement	4-391
Cab Door Replacement	4-392
Cab Door and Window Replacement and Repair	4-393
Backhoe Control Tower Replacement	4-404
Front Fender and Splash Guard Replacement	4-409
Splash Guard Replacement	4-412
Cab Door Seal Replacement	4-413
Cab Drain Plug Replacement	4-414
Cab Shock Absorbers and Mountings Replacement	4-415
Cab Tilt and Lower	4-418
Floor Platform Replacement	4-433
Operator Seat and Framework Replacement.	4-437
Operator Seat Framework Repair	4-442
Backhoe Seat Replacement	4-444
Backhoe Seat Repair	4-445
Passenger Seat and Framework Replacement	4-446
Seat Belt Replacement	4-451
Cab Floor Linings Replacement	4-454
Sun Visor, Clothes Hook, and Grip Handles Replacement	4-455
Roof Liner Replacement	4-458
Hose Reel Assembly Replacement and Repair	4-459
Hose Reel Motor Spring Replacement	4-464

	Page
Hydraulic Accessory Box Replacement and Repair	4-466
Hydraulic Accessory Box Replacement and Repair	4-468
Hydraulic Tool Hoses Replacement	4-471

FRONT PLATE REPLACEMENT

This task covers: a. Removal b. Installation

INITIAL SETUP

Tools and Special Equipment:

Personnel Required: (2)

Shop Equipment, SC 4910-95-CL-A74
Tool Kit, SC 5180-90-CL-N26

Materials/Parts:

Washer, Spring
Tension (2)

REMOVAL

1. REMOVE four screws (1), four washers (2), assembled front PLATE (3), and two brackets (4).

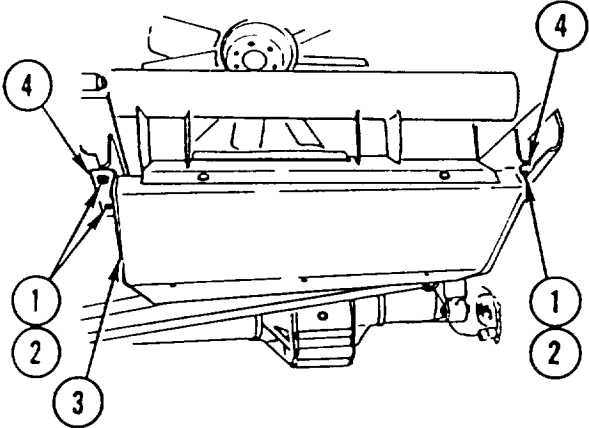

FRONT PLATE REPLACEMENT (CONT)

2. REMOVE two bolts (5), two spring tension washers (6), two washers (7), and COVER (8) from plate (9). DISCARD spring tension WASHERS.
3. IF WORN OR DAMAGED, REMOVE SEAL (10) from cover (8).

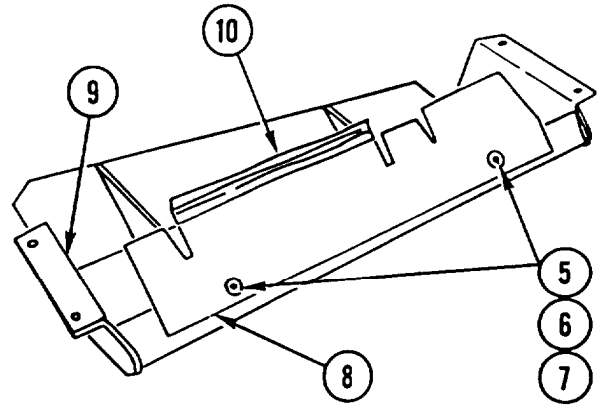

INSTALLATION

1. IF REMOVED, INSTALL new SEAL (1) on cover (2).
2. INSTALL COVER (2), two washers (3), two new spring tension washers (4), and two bolts (5) on plate (6).
3. INSTALL two brackets (7), assembled front PLATE (8), four washers (9), and four screws (10).

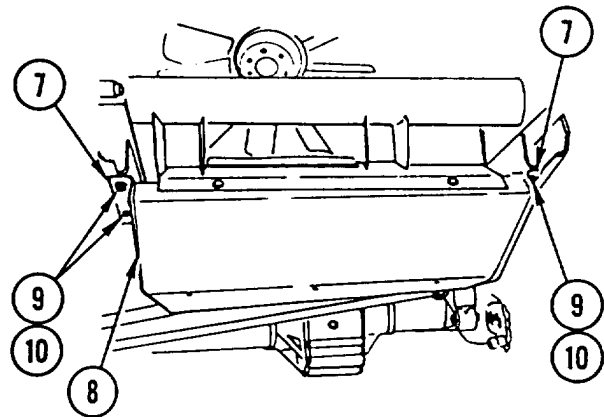
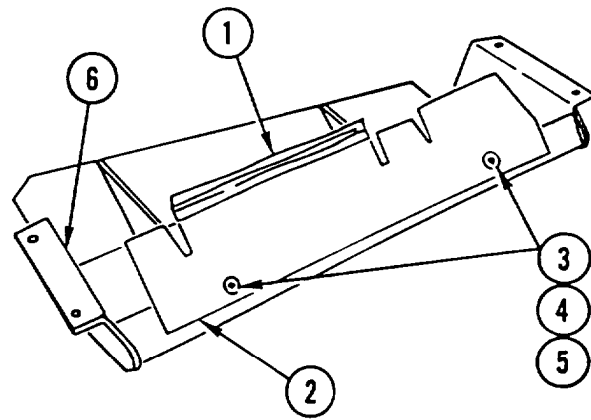

CANOPY (FOPS) REPLACEMENT

This task covers: a. Removal b. Installation

INITIAL SETUP

Tools and Special Equipment:

Shop Equipment, SC 4910-95-CL-A74
 Tool Kit, SC 5180-90-CL-N26

Materials/Parts:

Nut, Lock (10)

Equipment Condition:

Reference	Condition Description
Page 2-22	Backhoe in Three-Point Stance (SEE)

General Safety Instructions:

WARNING

Canopy weighs 260 pounds (118 kilograms). To avoid personal injury, use a hoist or suitable lifting device when lifting canopy.

REMOVAL

1. ATTACH suitable HOIST to lift points (1).

CAUTION

Remove all slack from hoist before removing screws to prevent damage to equipment.

2. REMOVE 10 bolts (2), 10 lock nuts (3), and CANOPY (4). DISCARD lock NUTS.

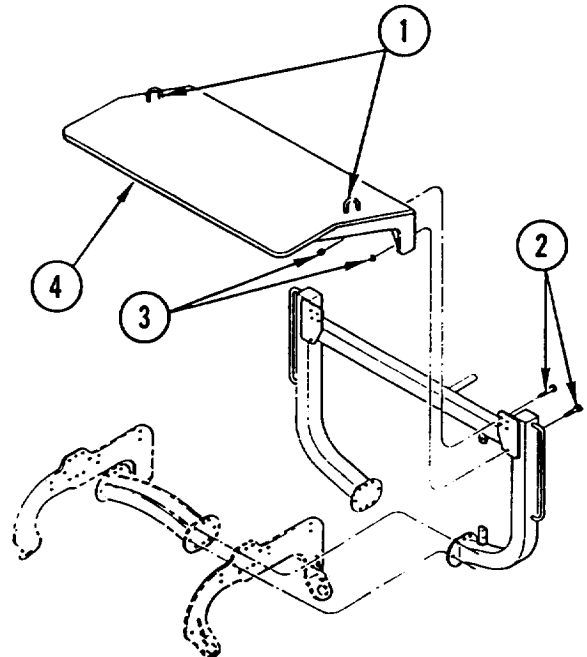

INSTALLATION

1. LIFT CANOPY (4) into place and INSTALL 10 BOLTS (2) and 10 new lock nuts (3). TIGHTEN BOLTS to 75 lb-ft (102 N•m).
2. REMOVE HOIST from lift points (1).

OUTSIDE ENGINE HOOD REPLACEMENT

This task covers. a. Removal b. Installation

INITIAL SETUP

Personnel Required: (2)

REMOVAL

1. USING WRENCH located in driver's door, RELEASE two STAYS (1 and 2).

CAUTION

Do not catch hood on brake fluid reservoir or windshield washer reservoir when removing hood with front loader installed. To do so could result in equipment damage.

2. LIFT HOOD (3), RELEASE hood LATCH (4), and REMOVE HOOD (3).

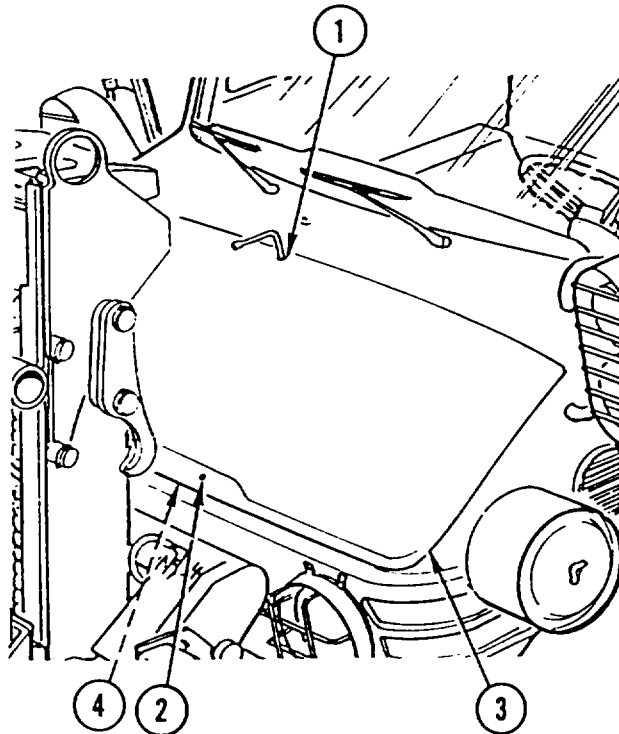

INSTALLATION

1. INSTALL HOOD (3) and SECURE hood LATCH (4).
2. USING WRENCH located in driver's door, LATCH two STAYS (1 and 2)

INSIDE ENGINE HOOD REPLACEMENT

This task covers: a. Removal b. Installation

REMOVAL

DISCONNECT five FASTENERS (1) and REMOVE inside engine HOOD (2) through passenger side of vehicle.

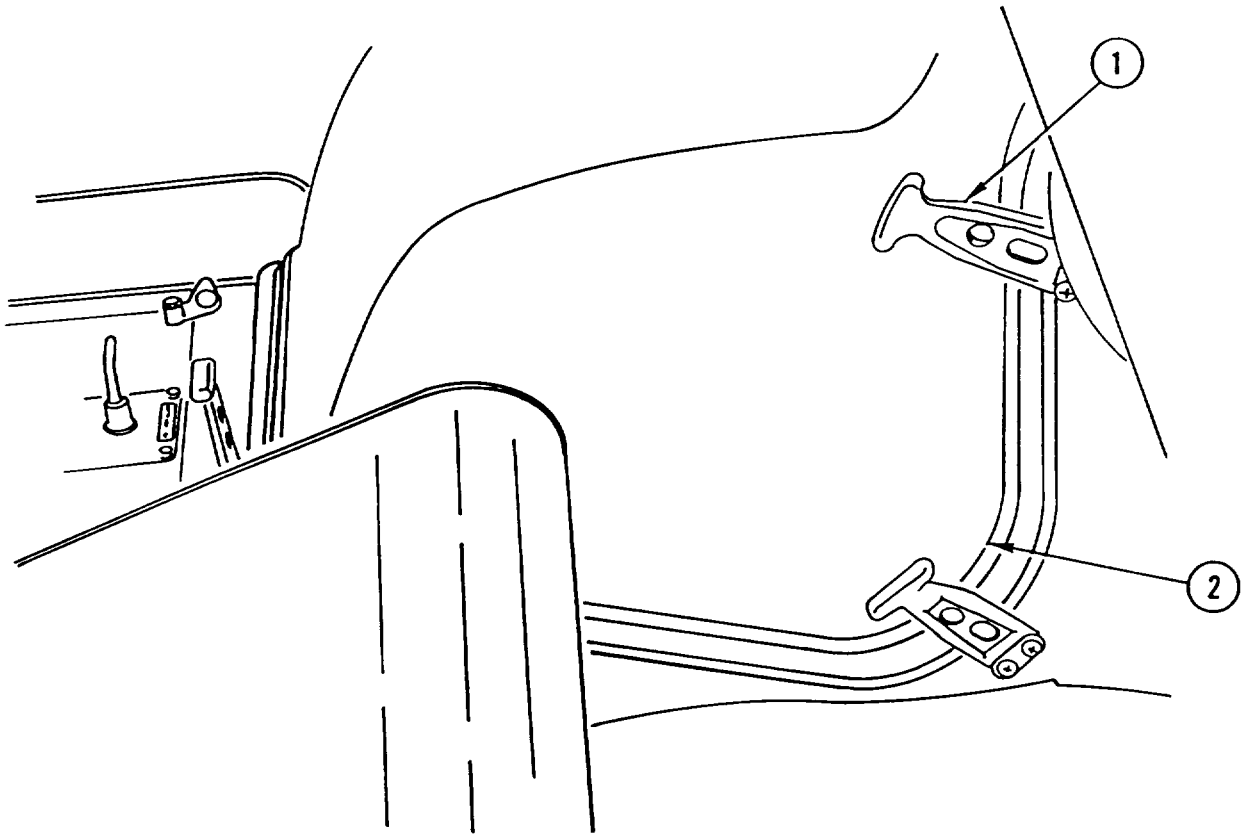

INSTALLATION

INSTALL inside engine HOOD (2) through passenger side of vehicle and CONNECT five FASTENERS (1).

SPARE TIRE AND MOUNT REPLACEMENT

This task covers: a. Removal b. Installation

INITIAL SETUP

Applicable Configuration:

SEE

Tools and Special Equipment:

Tool Kit, SC 5180-90-CL-N26

Personnel Required: (4)

General Safety Instructions:

WARNING
Wheel assembly weighs 170 pounds (77 kilograms). To avoid personal injury, use a hoist or suitable lifting device when lifting wheel assembly.

REMOVAL

1. REMOVE holder (1) and WHEEL (2).
2. REMOVE four nuts (3), four washers (4), four bolts (5), and BRACKET (6).

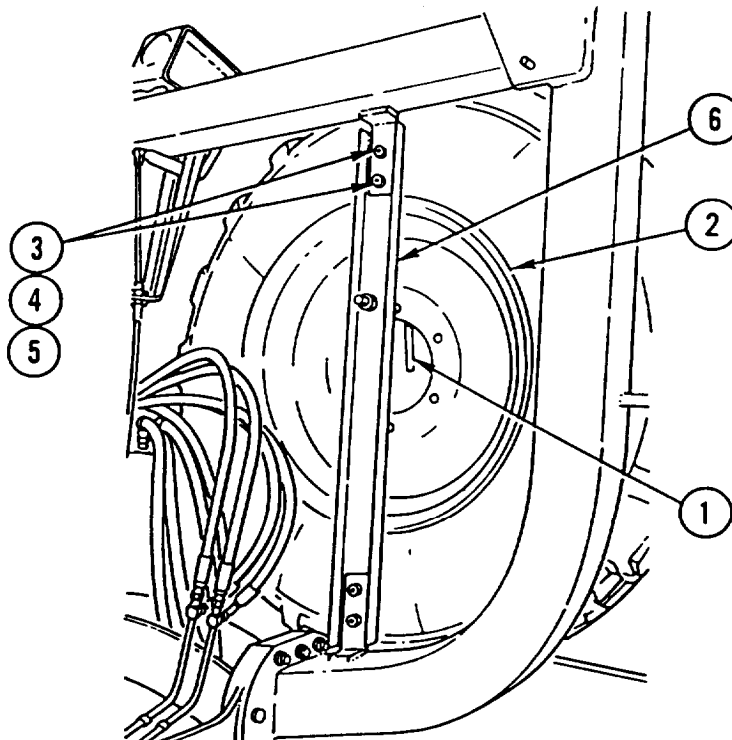

INSTALLATION

1. INSTALL BRACKET (6), four bolts (5), four washers (4), and four nuts (3).
2. INSTALL WHEEL (2) and holder (1).

SPARE TIRE AND MOUNT REPLACEMENT

This task covers: a. Removal b. Installation

INITIAL SETUP

Applicable Configuration:

HMMH

General Safety Instructions:

WARNING

Wheel assembly weighs 170 pounds (77 kilograms). To avoid personal injury, use a hoist or suitable lifting device when lifting wheel assembly.

Tools and Special Equipment:

Tool Kit, SC 5180-90-CL-N26

Materials/Parts:

Nut, Lock (2)

Personnel Required: (4)

REMOVAL

1. REMOVE holder (1) and WHEEL (2).
2. REMOVE two lock nuts (3), clamp (4), two bolts (5), and BRACKET (6). DISCARD lock NUTS.

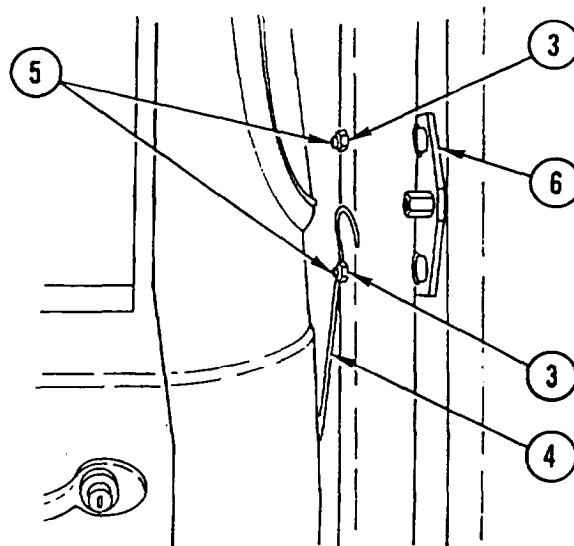
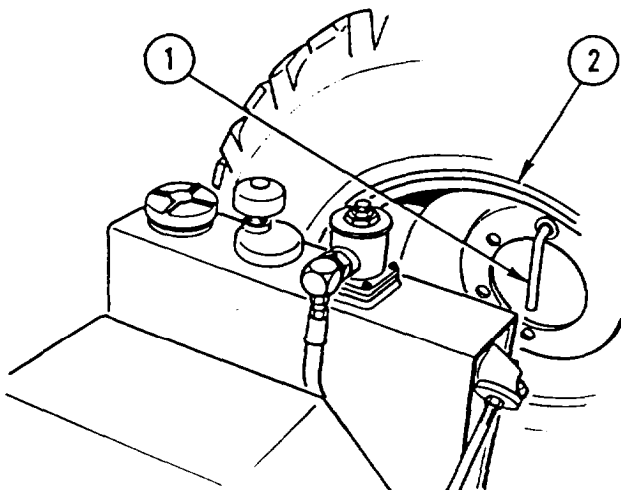

INSTALLATION

1. INSTALL BRACKET (6), two bolts (5), clamp (4), and two new lock nuts (3).
2. INSTALL WHEEL (2) and holder (1).

CAB DOOR REPLACEMENT

This task covers: a. Removal b. Installation

INITIAL SETUP

Tools and Special Equipment:

Tool Kit, SC 5180-90-CL-N26

Materials/Parts:

Grease, Automotive
and Artillery (GAA)

Appendix C, Item 19

REMOVAL

NOTE

Procedure is the same for both doors.

OPEN DOOR (1) and LIFT from hinges (2).

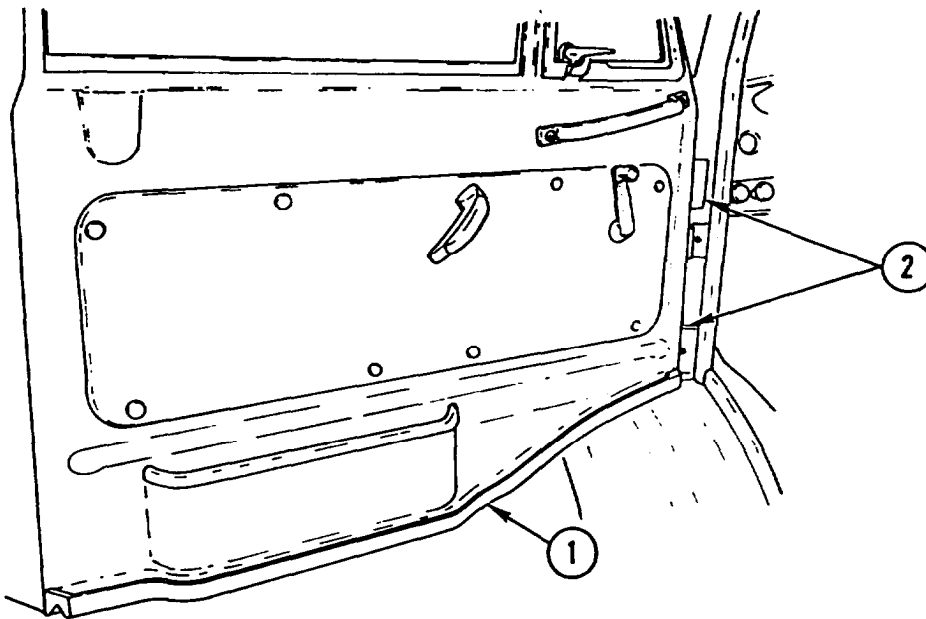

INSTALLATION

NOTE

Procedure is the same for both doors.

1. APPLY light COAT of GAA to hinge (2) PINS.
2. INSTALL DOOR (1) on hinges (2).

CAB DOOR AND WINDOW REPLACEMENT AND REPAIR

This task covers: a. Removal b. Disassembly c. Assembly d. Installation

INITIAL SETUP

Tools and Special Equipment:

Tool Kit, SC 5180-90-CL-N26

Materials/Parts:

Washer, Spring
Tension

Washer, Spring
Tension

Washer, Spring
Tension (4)

Washer, Spring
Tension (6)

Washer, Spring
Tension (2)

Seal

Materials/Parts (Cont):

Tape

Kit

Kit

Personnel Required: (2)

General Safety Instructions:

WARNING

Edges of glass may be sharp.
To avoid personal injury, wear
protective gloves when handling
glass.

REMOVAL

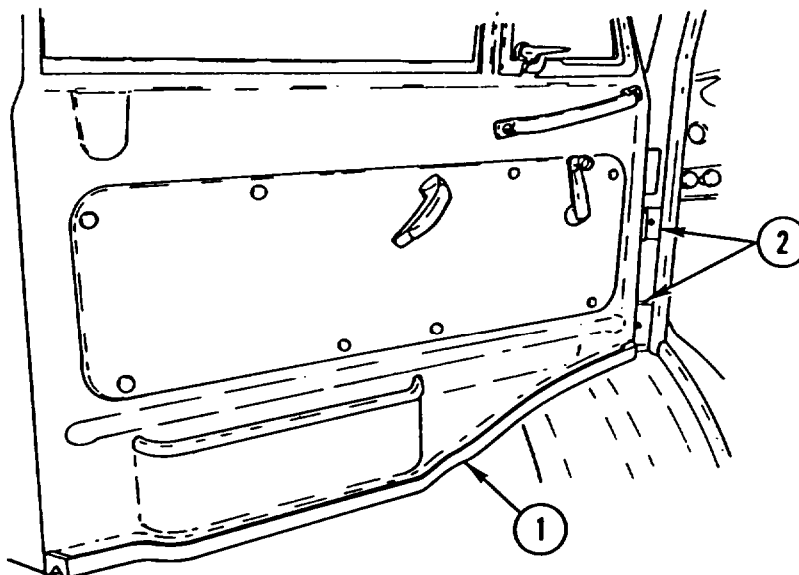

NOTE

Procedure is the same for both doors.

OPEN DOOR (1) and LIFT from hinges (2).

CAB DOOR AND WINDOW REPLACEMENT AND REPAIR (CONT)

DISASSEMBLY

NOTE

Procedure is the same for both doors except as noted.

1. If DAMAGED, REMOVE CHANNEL (1).
2. If DAMAGED, REMOVE weather STRIP (2).

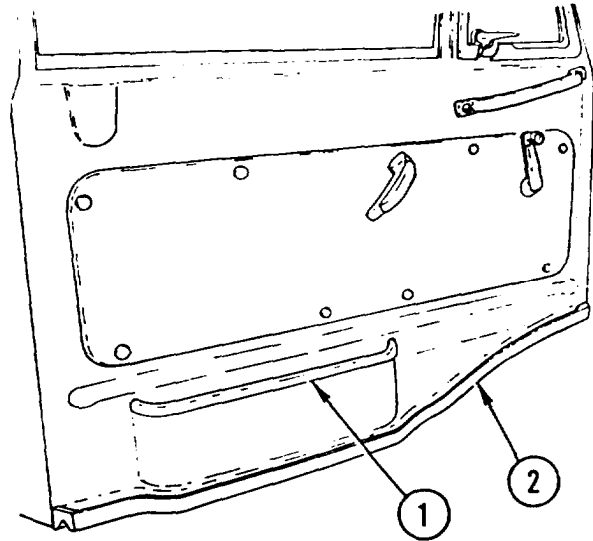

3. FROM LEFT door, REMOVE two screws (3) and HANDLE (4).
4. REMOVE cover (5), bolt (6), door HANDLE (7), and escutcheon plate (8).
5. REMOVE pad (9), bolt (10), window HANDLE (11), and escutcheon plate (12).
6. REMOVE access COVER (13).

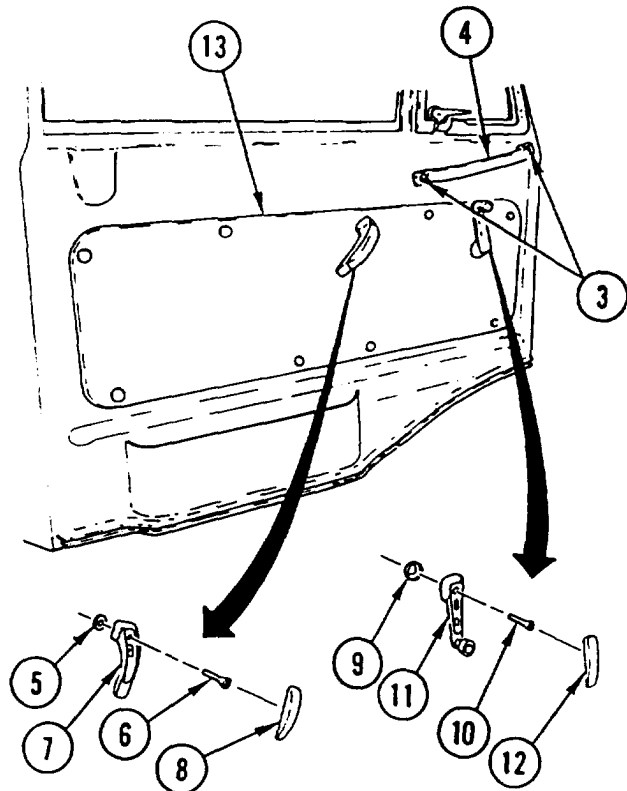

CAB DOOR AND WINDOW REPLACEMENT AND REPAIR (CONT)

7. REMOVE SCREW (14) and spring tension washer (15). DISCARD spring tension WASHER.
- a. LOOSEN SCREW (16) inside door (17) and REMOVE door HANDLE (18).
9. REMOVE two SCREWS (19) and four washers (20 and 21) from latch end of door (17).

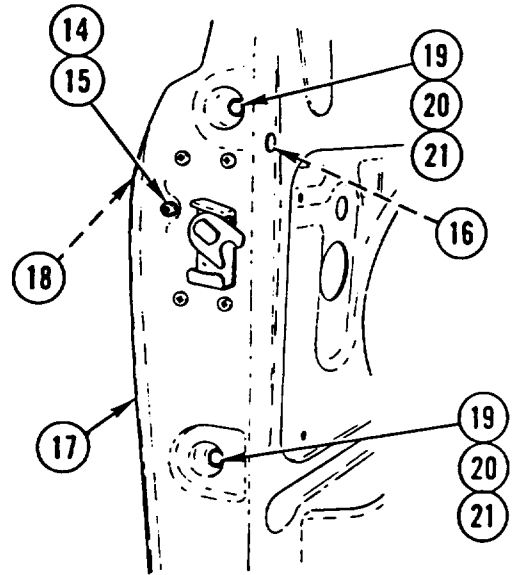

10. REMOVE SCREW (22) and two washers (23 and 24) from hinge end of door (17).

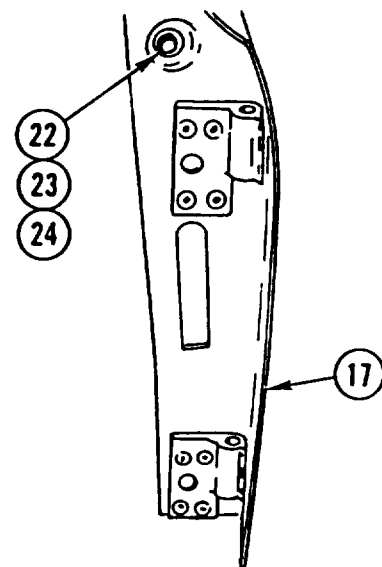

CAB DOOR AND WINDOW REPLACEMENT AND REPAIR (CONT)

11. REMOVE SCREW (25), washer (26), and spring tension washer (27) from bottom edge of door (17). DISCARD spring tension WASHER.

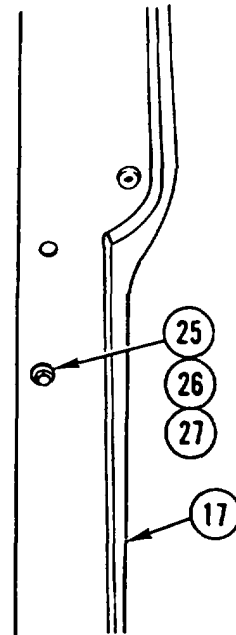

NOTE

Make sure window is completely raised.

12. REMOVE FRAME assembly (28).
13. REMOVE WINDOW (29).
14. REMOVE four screws (30), four spring tension washers (31), and REGULATOR (32). DISCARD spring tension WASHERS.
15. REMOVE six screws (33), six spring tension washers (34), and door LATCH (35). DISCARD spring tension WASHERS.

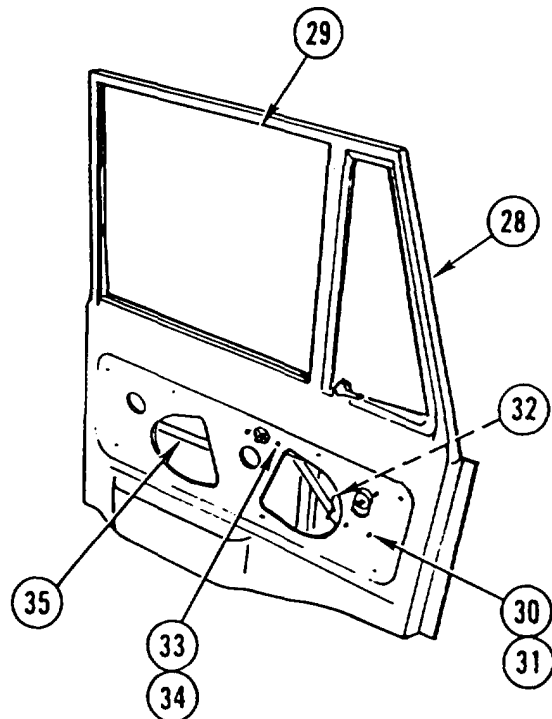

CAB DOOR AND WINDOW REPLACEMENT AND REPAIR (CONT)

16. REMOVE eight bolts (36) and two HINGES (37).

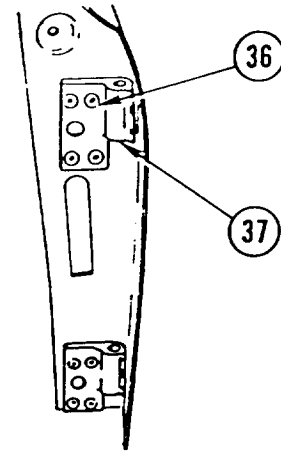

17. REMOVE two nuts (38), five washers (39), two screws (40), two spring tension washers (41), mounting (42), and WINDOW assembly (43). DISCARD spring tension WASHERS.
18. IF DAMAGED, REMOVE SEAL (44).
19. REMOVE screw (45) and MOUNTING (46).

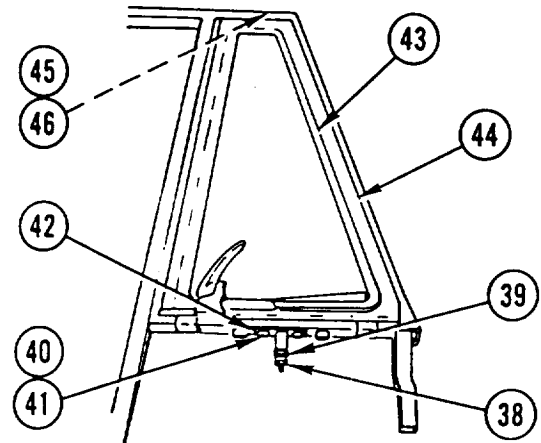

20. REMOVE and DISCARD PIN (47), GRINDER (48), two DISCS (49 and 50), and AXLE (51).
21. REMOVE WINDOW (52) from window frame (53).

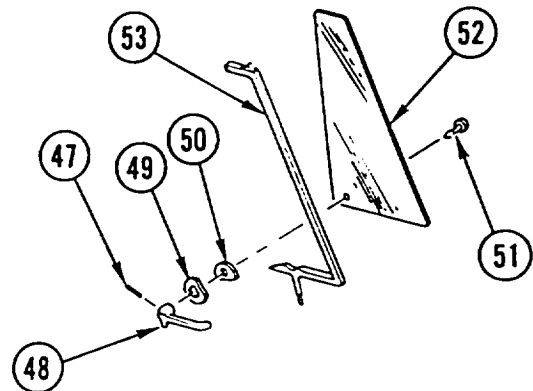

CAB DOOR AND WINDOW REPLACEMENT AND REPAIR (CONT)

- 22. IF DAMAGED, REMOVE SEAL (54) and three SEALS (55, 56, and 57) from frame assembly (28).
- 23. IF DAMAGED, REMOVE two ADAPTERS (58) and two SEALS (59).

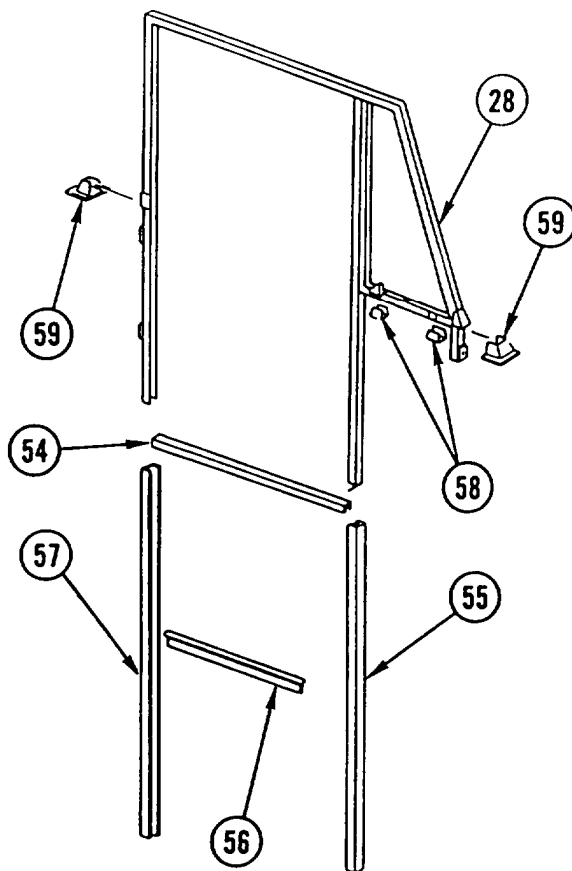

- 24. REMOVE CHANNEL (60).
- 25. REMOVE and DISCARD SEAL (61) and TAPE (62) from window (29).

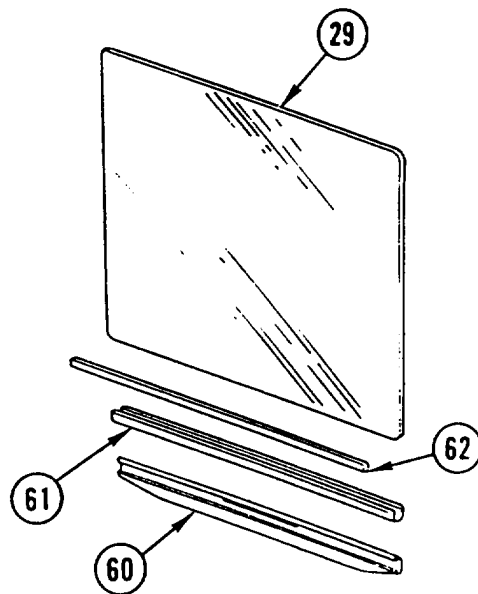

CAB DOOR AND WINDOW REPLACEMENT AND REPAIR (CONT)

ASSEMBLY

CAUTION
 Make sure parts in steps 1 and 2 are centered on window.
 Failure to do so will affect window operation.

NOTE

Procedure is the same for both doors except as noted.

1. INSTALL new TAPE (1) and new SEAL (2) on window (3).
2. INSTALL CHANNEL (4) on window (3).

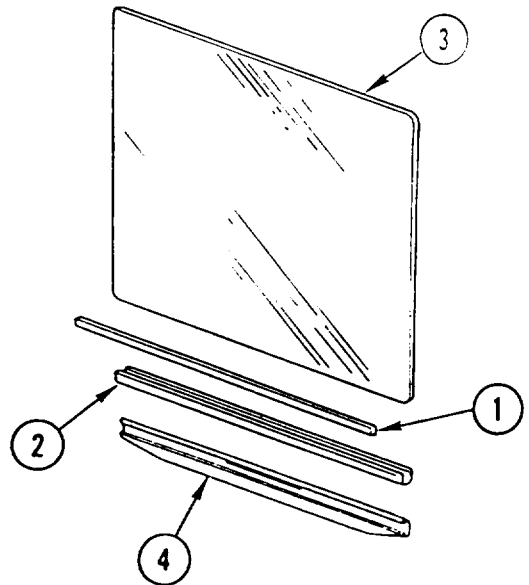

3. IF REMOVED, INSTALL two new SEALS (5) and two new ADAPTERS (6).
4. IF REMOVED, INSTALL three new SEALS (7, 8, and 9) and new SEAL (10) on frame assembly (11).

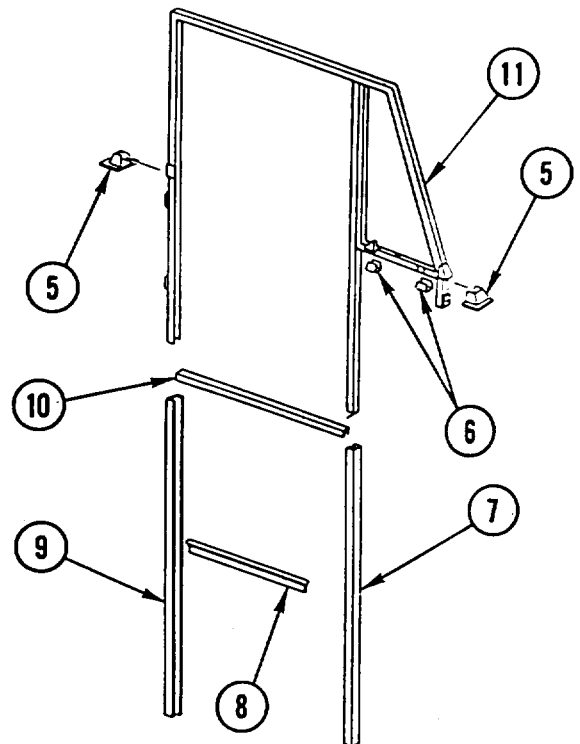

CAB DOOR AND WINDOW REPLACEMENT AND REPAIR (CONT)

5. INSTALL WINDOW (12) in window frame (13).
6. INSTALL new axle (14), two new discs (15 and 16), new GRINDER (17), and new pin (18).
7. INSTALL MOUNTING (19) and screw (20).

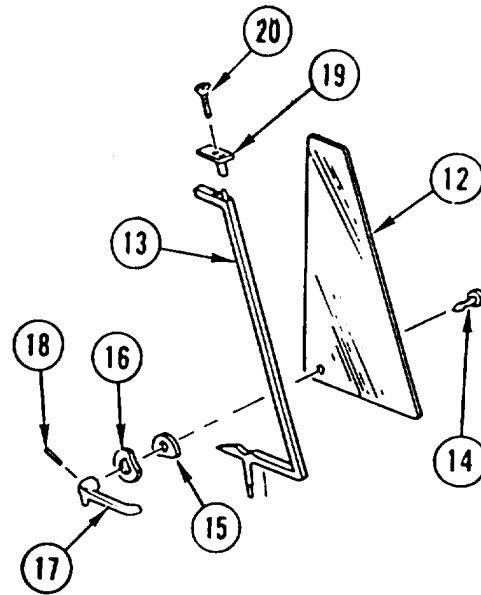

8. IF REMOVED, INSTALL new SEAL (21).
9. INSTALL WINDOW assembly (22), mounting (23), two new spring tension washers (24), two screws (25), five washers (26), and two nuts (27).

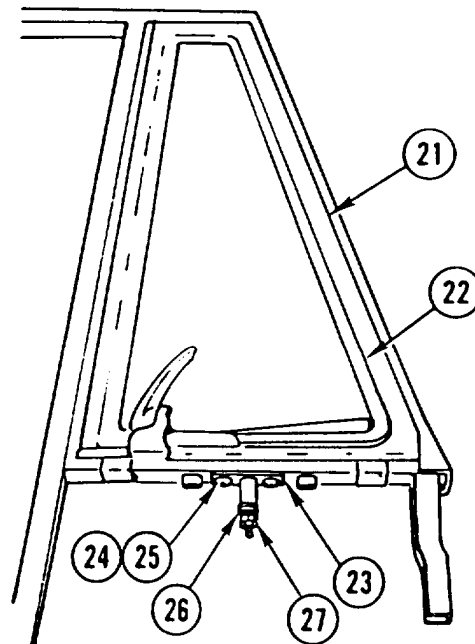

CAB DOOR AND WINDOW REPLACEMENT AND REPAIR (CONT)

- 10. INSTALL door LATCH (28), six new spring tension washers (29), and six screws (30).
- 11. INSTALL REGULATOR (31), four new spring tension washers (32), and four screws (33).
- 12. INSTALL WINDOW (3).
- 13. INSTALL FRAME assembly (11) in door (34).

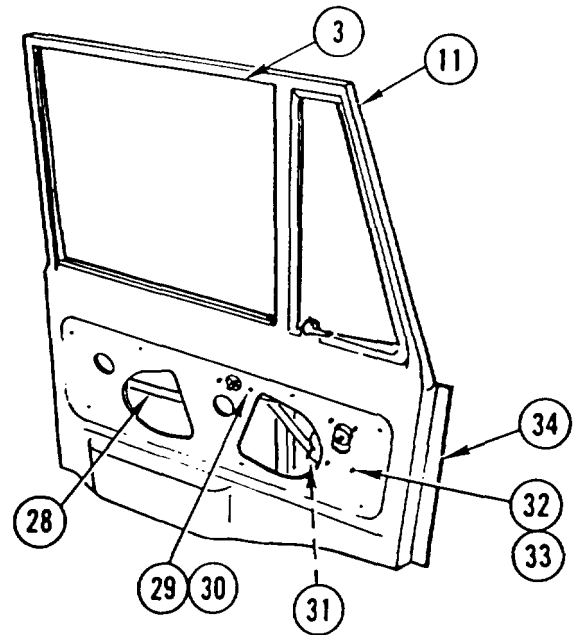

- 14. INSTALL washer (35), new spring tension washer (36), and SCREW (37) in bottom edge of door (34).

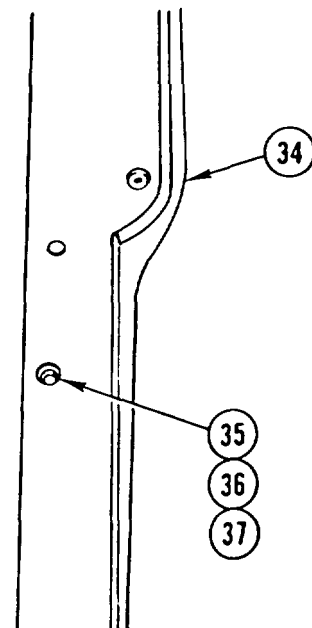

CAB DOOR AND WINDOW REPLACEMENT AND REPAIR (CONT)

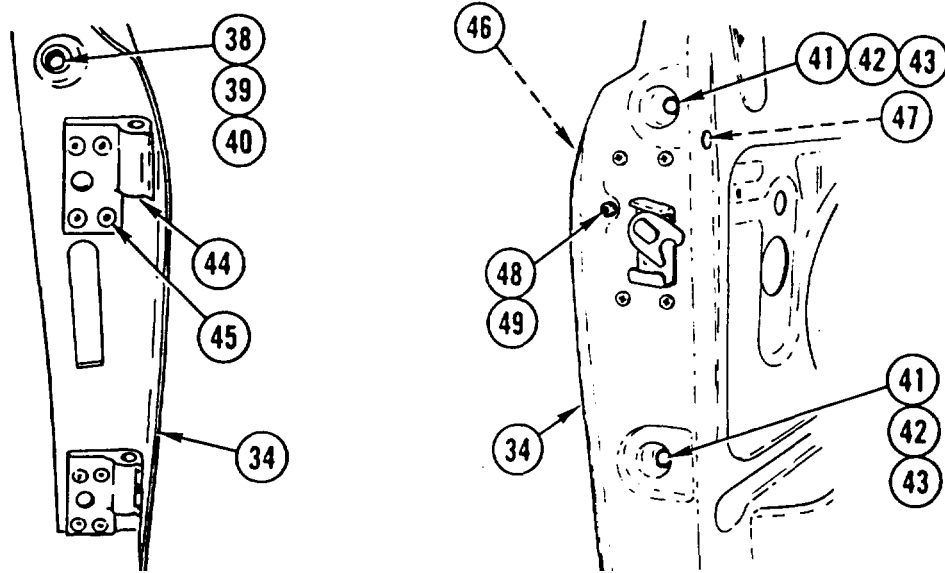

15. INSTALL two washers (38 and 39) and SCREW (40) in hinge end of door (34).
16. INSTALL four washers (41 and 42) and two SCREWS (43) in latch end of door (34).
17. INSTALL two HINGES (44) and eight bolts (45).
18. INSTALL door HANDLE (46) in door (34) and TIGHTEN SCREW (47).
19. INSTALL new spring tension washer (48) and SCREW (49).

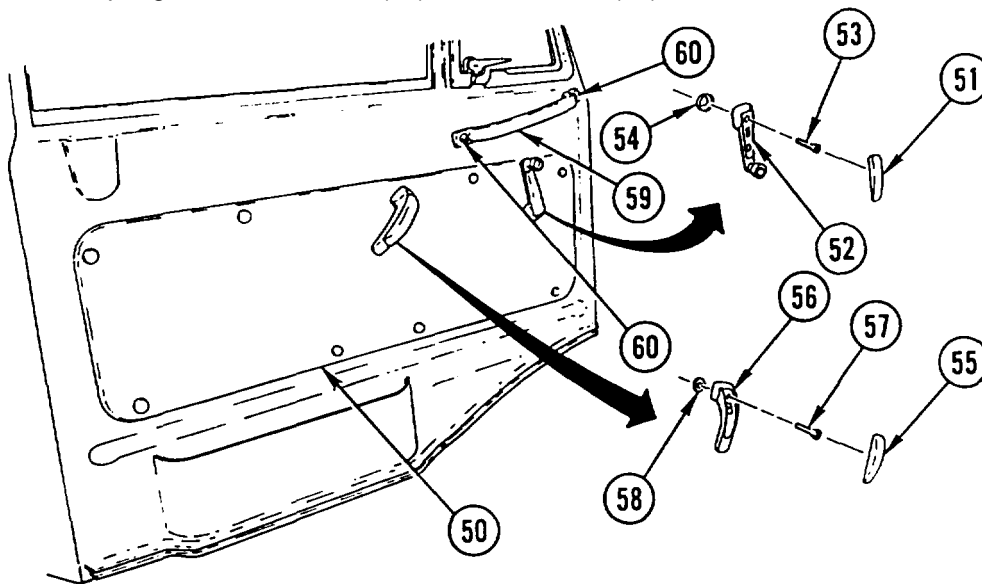

20. INSTALL access COVER (50).
21. INSTALL escutcheon plate (51), window HANDLE (52), bolt (53), and 'pad (54).
22. INSTALL escutcheon plate (55), door HANDLE (56), bolt (57), and cover (58).
23. ON LEFT DOOR, INSTALL HANDLE (59) and two screws (60).

CAB DOOR AND WINDOW REPLACEMENT AND REPAIR (CONT)

24. IF REMOVED, INSTALL new weather STRIP (61).

25. IF REMOVED, INSTALL new CHANNEL (62).

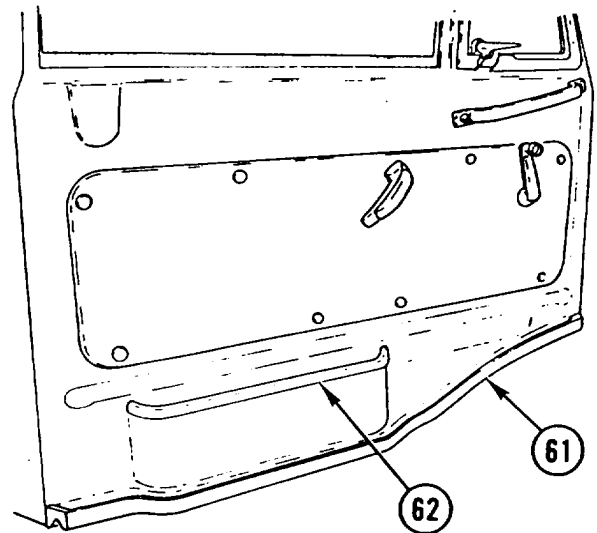

INSTALLATION

NOTE

Procedure is the same for both doors.

INSTALL DOOR (1) on hinges (2).

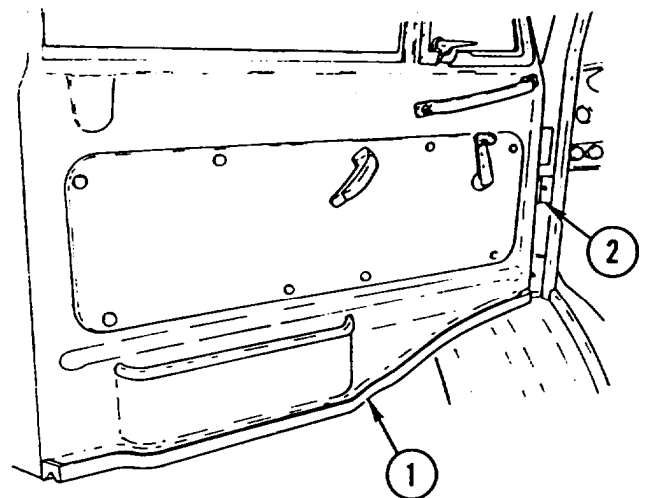

BACKHOE CONTROL TOWER REPLACEMENT

This task covers: a. Removal b. Installation

INITIAL SETUP

Applicable Configuration:

SEE

Tools and Special Equipment:

Tool Kit, SC 5180-90-CL-N26

Personnel Required: (2)

Equipment Condition:

Reference

Page 4-444

Condition Description

Backhoe Seat Removed

Materials/Parts:

Pin, Cotter (6)

Nut, Lock (4)

REMOVAL

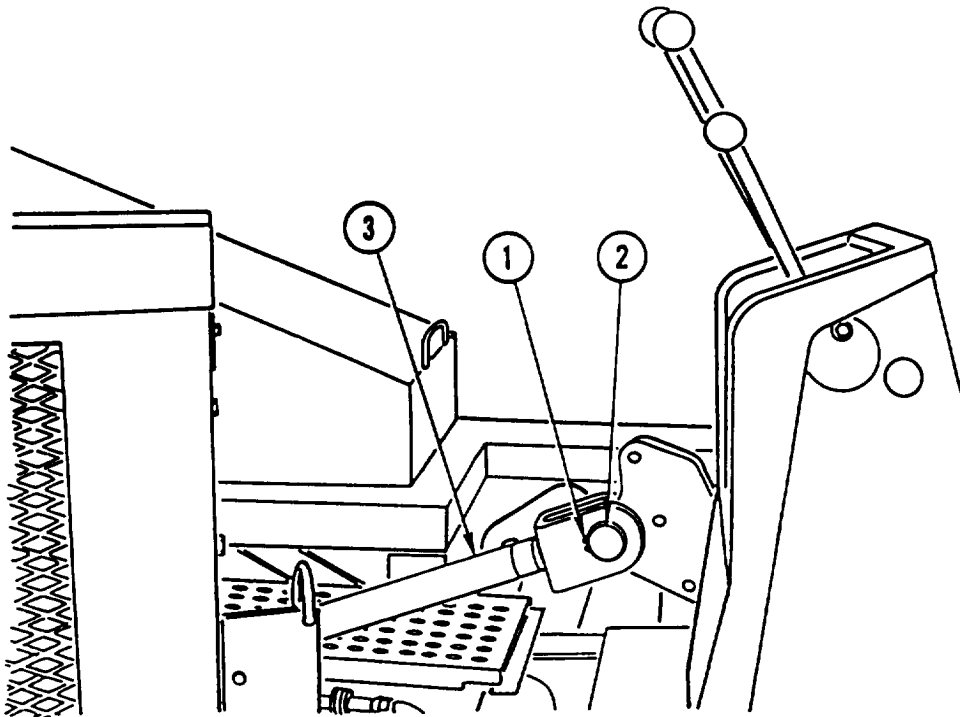

1. REMOVE two retaining rings (1) and PIN (2) and SECURE tilt CYLINDER (3) out of the way.

BACKHOE CONTROL TOWER REPLACEMENT (CONT)

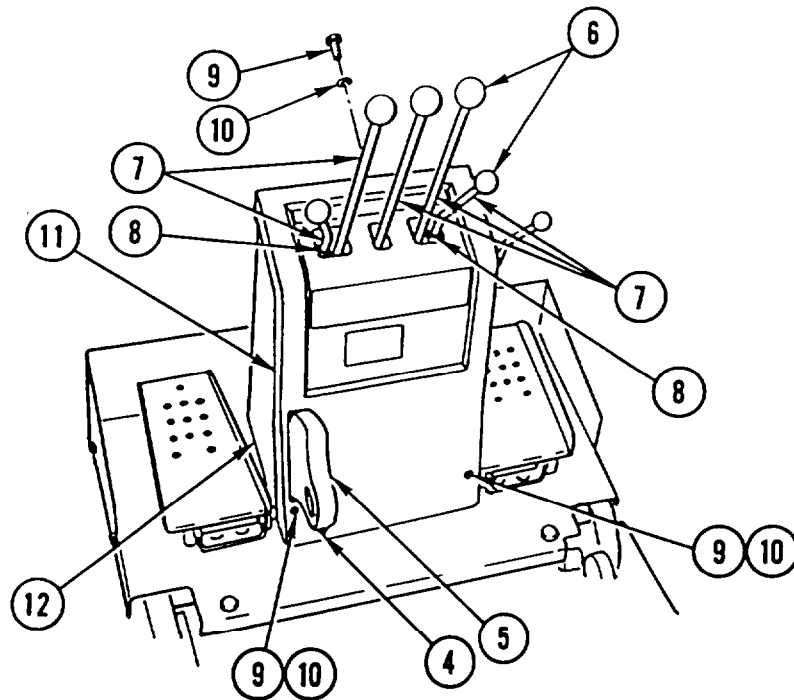

2. REMOVE grease FITTING (4) from bracket (5).
3. REMOVE five KNOBS (6) from five control levers (7).
4. LOOSEN two NUTS (8) and ROTATE two outer control LEVERS (7) in toward center.
5. REMOVE three self-tapping screws (9), three washers (10), and COVER (11) from control tower (12).

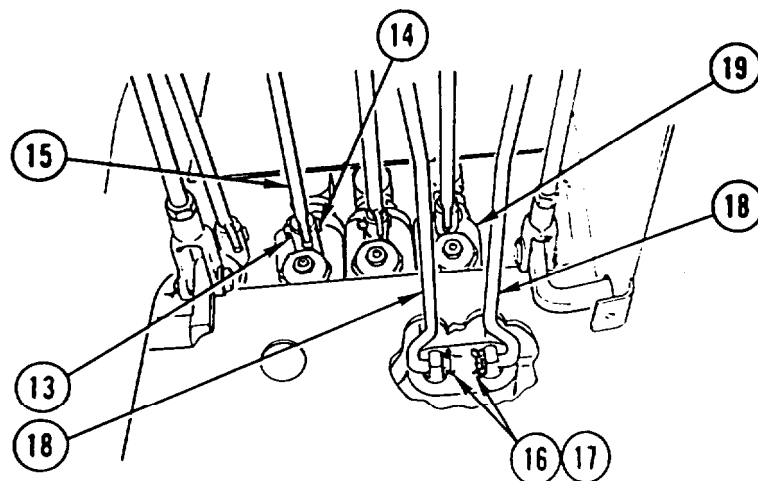

6. REMOVE four cotter pins (13) and four PINS (14) from four control rods (15). DISCARD cotter PINS.
7. REMOVE two cotter PINS (16) and two washers (17) from two control rods (18). DISCARD cotter PINS.
8. DISCONNECT two control RODS (18) from backhoe control valve (19).

BACKHOE CONTROL TOWER REPLACEMENT (CONT)

- REMOVE four lock nuts (20), four washers (21), and four SCREWS (22) from backhoe guard and plate assembly (23) and mounting brackets (24). DISCARD lock NUTS.

NOTE

While performing step 10, it may be necessary to use two personnel.

- REMOVE backhoe GUARD and PLATE assembly (23) from four mounts (25) and mounting brackets (24).
- REMOVE four MOUNTS (25) from mounting brackets (24).

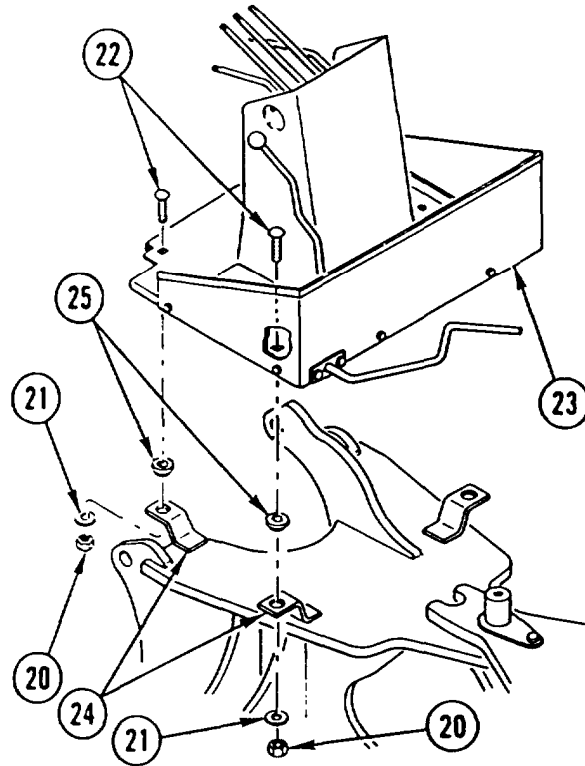

INSTALLATION

- INSTALL four MOUNTS (1) in mounting brackets (2).

NOTE

While performing step 2, it may be necessary to use two personnel.

- USING suitable LIFTING DEVICE, INSTALL backhoe GUARD and PLATE assembly (3) on four mounts (1).
- INSTALL four SCREWS (4), four washers (5), and four new lock nuts (6) in backhoe guard and plate assembly (3) and mounting brackets (2).

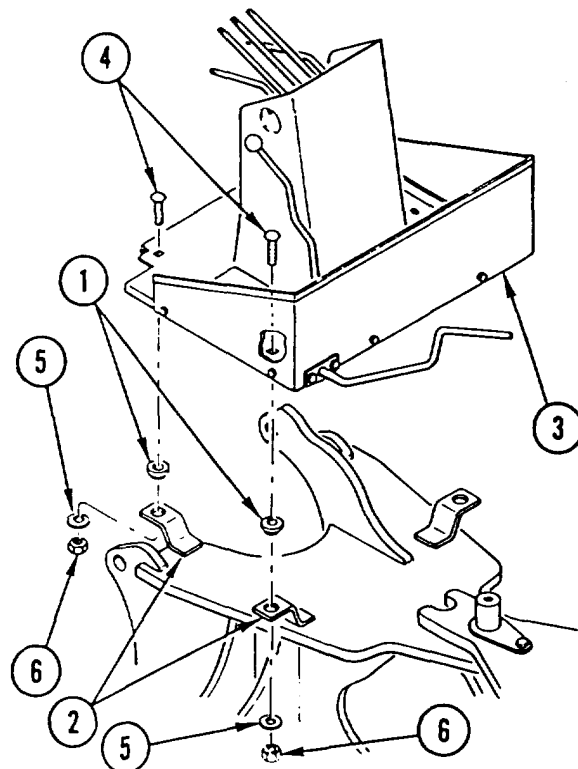

BACKHOE CONTROL TOWER REPLACEMENT (CONT)

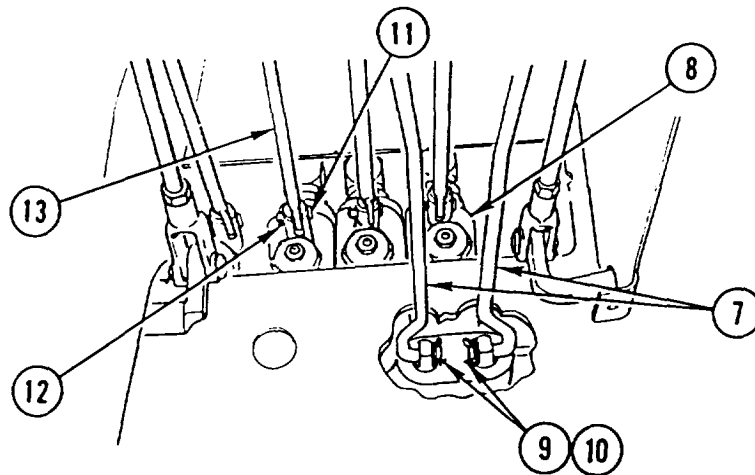

4. CONNECT two control RODS (7) to backhoe control valve (8).
5. INSTALL two washers (9) and two new cotter PINS (10) in two control rods (7).
6. INSTALL four PINS (11) and four new cotter pins (12) in four control rods (13) and backhoe control valve (8).

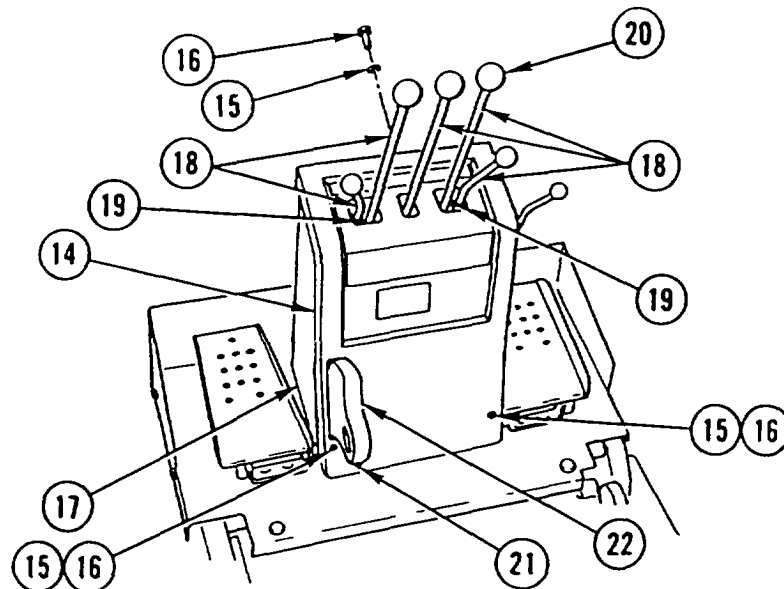
**NOTE**

If needed, adjust control rods at this time (page 4-531).

7. INSTALL COVER (14), three washers (15), and three self-tapping screws (16) in control tower (17).
6. ROTATE two outer control LEVERS (18) outward from center and TIGHTEN two NUTS (19).
9. INSTALL five KNOBS (20) on five control levers (18).
10. INSTALL grease FITTING (21) in bracket (22).

BACKHOE CONTROL TOWER REPLACEMENT (CONT)

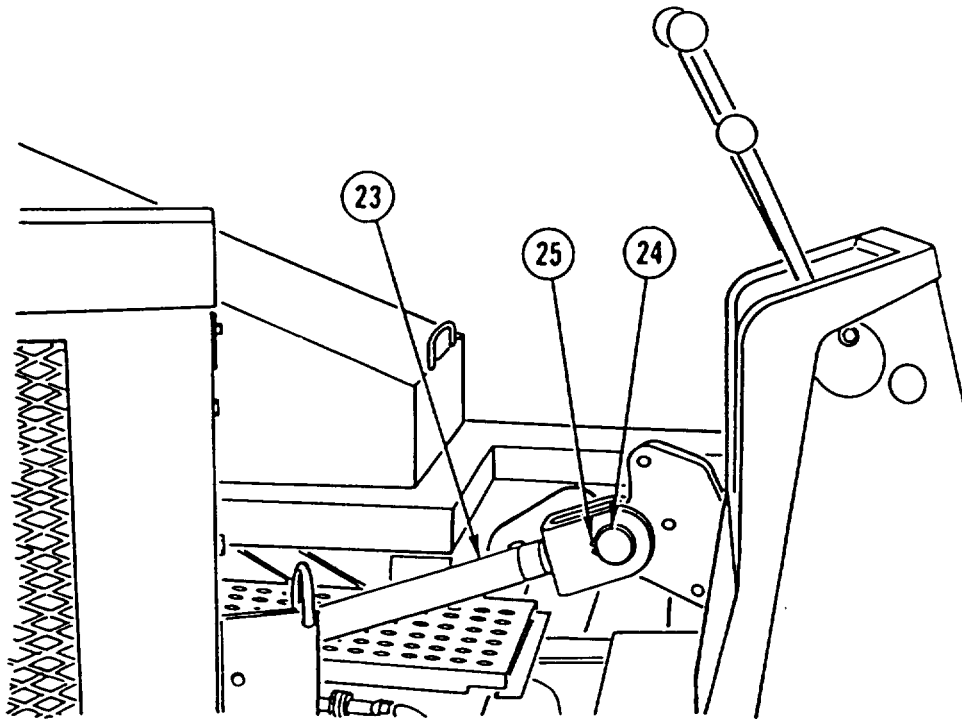

11. CONNECT tilt CYLINDER (23) and INSTALL PIN (24) and two retaining rings (25).

NOTE

Follow-on Maintenance:

Install backhoe seat (page 4-444).

FRONT FENDER AND SPLASH GUARD REPLACEMENT

This task covers: a. Removal b. Installation

INITIAL SETUP

Tools and Special Equipment:

Tool Kit, SC 5180-90-CL-N26

Materials/Parts:

Washer, Spring
Tension (2)

Washer, Lock (5)

Washer, Spring
Tension (5)

Packing (5)

REMOVAL

NOTE

Procedure is the same for both front fenders.

1. REMOVE two bolts (1), two spring tension washers (2), and front FENDER (3). DISCARD spring tension WASHERS.

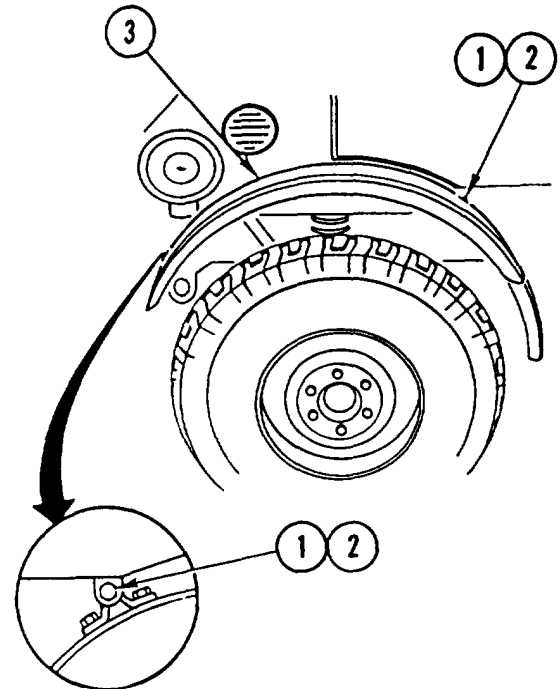

2. REMOVE two screws (4), two lock washers (5), two spring tension washers (6), and front BRACKET (7). DISCARD lock WASHERS and spring tension WASHERS.
3. IF DAMAGED, REMOVE three BUMPERS (8).

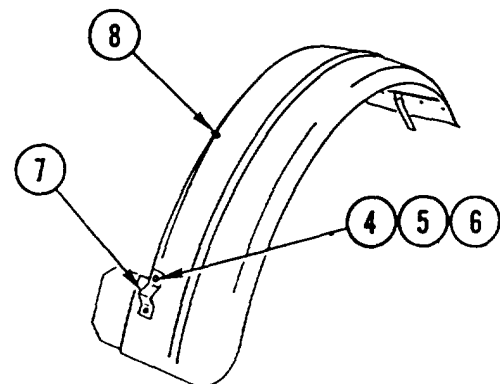

FRONT FENDER AND SPLASH GUARD REPLACEMENT (CONT)

4. REMOVE three screws (9), three lock washers (10), three spring tension washers (11), and rear BRACKET (12). DISCARD lock WASHERS and spring tension WASHERS.
5. REMOVE five bolts (13), five packings (14), five washers (15), five nuts (16), rail (17), and splash GUARD (18). DISCARD PACKINGS.

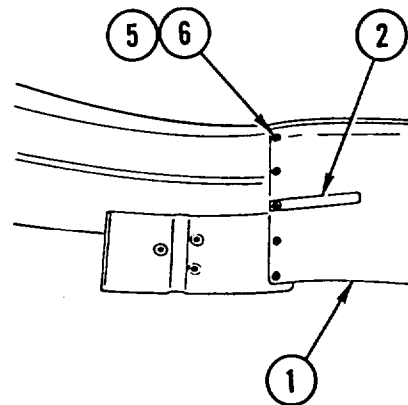
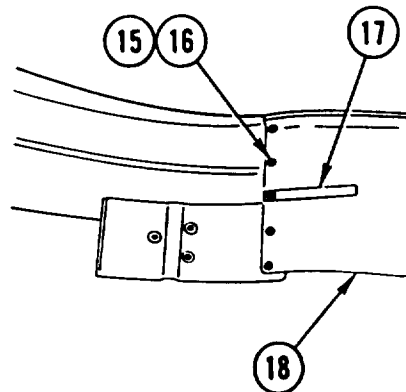
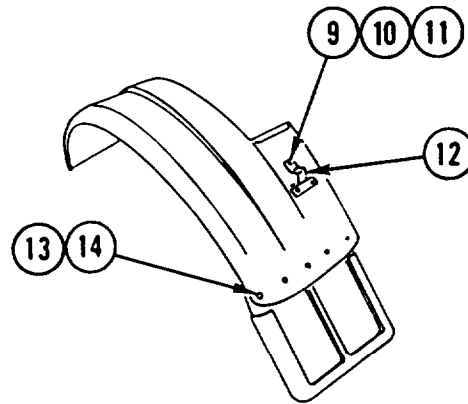

INSTALLATION

NOTE

Procedure is the same for both front fenders.

1. INSTALL splash GUARD (1), rail (2), five bolts (3), five new packings (4), five washers (5), and five nuts (6).
2. INSTALL rear BRACKET (7), three screws (8), three new lock washers (9), and three new spring tension washers (10).

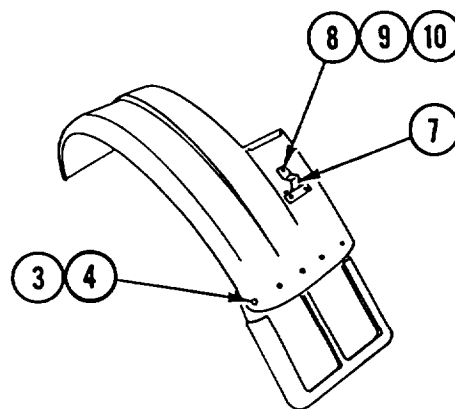

FRONT FENDER AND SPLASH GUARD REPLACEMENT (CONT)

3. IF REMOVED, INSTALL three new BUMPERS (11).
4. INSTALL front BRACKET (12), two screws (13), two new lock washers (14), and two new spring tension washers (15).

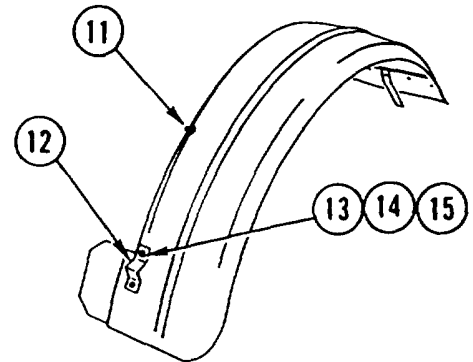

5. INSTALL front FENDER (16), two bolts (17), and two new spring tension washers (18).

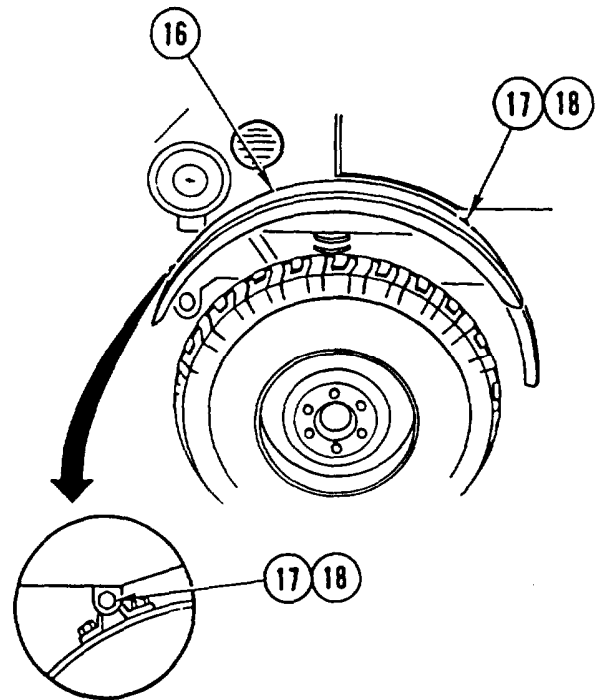

SPLASH GUARD REPLACEMENT

This task covers: a. Removal b. Installation

INITIAL SETUP

Tools and Special Equipment:

Too Kit, SC 5180-90-CL-N26

Materials/Parts:

Washer, Lock (4)

Washer, Lock (3)

REMOVAL

1. ON LEFT SIDE, REMOVE four nuts (1), four screws (2), four washers (3), four lock washers (4), STEP (5), and splash GUARD (6). DISCARD lock WASHERS.
2. ON RIGHT SIDE, REMOVE three nuts (7), three screws (8), three washers (9), three lock washers (10), and splash GUARD (11). DISCARD lock WASHERS.

INSTALLATION

1. ON RIGHT SIDE, INSTALL splash GUARD (11), three screws (8), three washers (9), three new lock washers (10), and three nuts (7).
2. ON LEFT SIDE, INSTALL splash GUARD (6), STEP (5), four screws (2), four washers (3), four new lock washers (4), and four nuts (1).

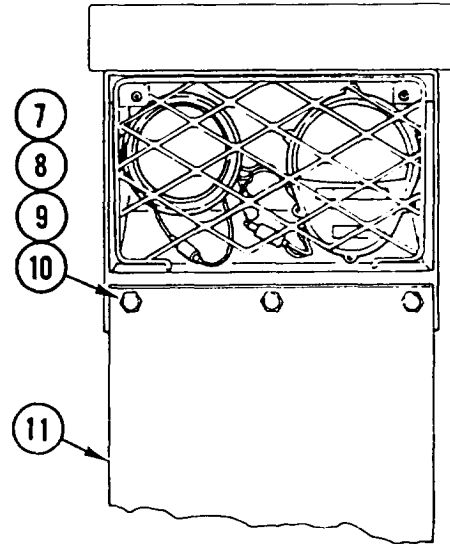
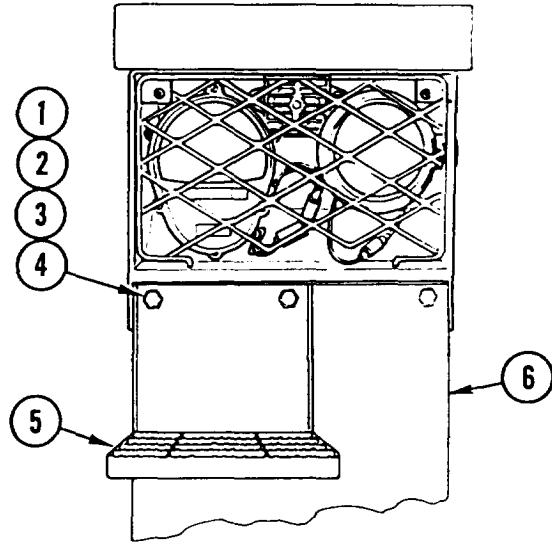

CAB DOOR SEAL REPLACEMENT

This task covers: a. Removal b. Installation

INITIAL SETUP

Tools and Special Equipment:

Tool Kit, SC 5180-90-CL-N26

REMOVAL

NOTE

Procedure is the same for both doors.

CAREFULLY PULL door SEAL (1) from flange (2) all the way around cab door opening.

INSTALLATION

NOTE

Procedure is the same for both doors.

START at one end of cab door opening and PRESS door SEAL (1) into flange (2) all the way around opening.

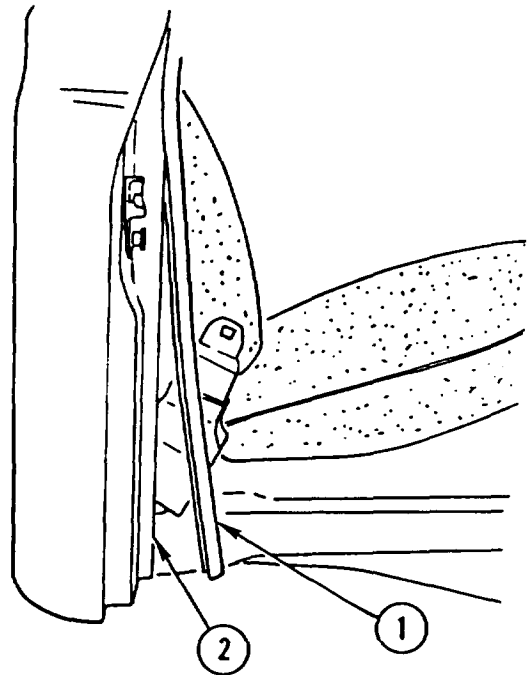

CAB DRAIN PLUG REPLACEMENT

This task covers: a. Removal b. Installation

INITIAL SETUP

Tools and Special Equipment:

Tool Kit, SC 5180-90-CL-N26

REMOVAL

REMOVE cab drain PLUG (1) from cab floor (2).

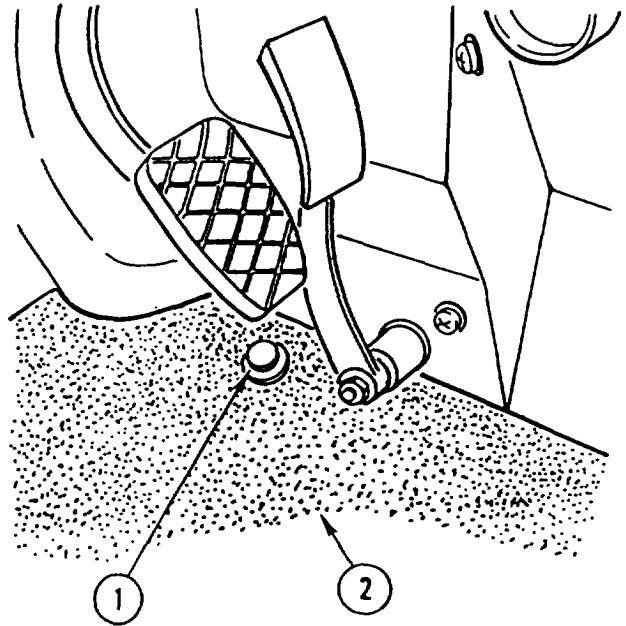

INSTALLATION

INSTALL cab drain PLUG (1) in cab floor (2).

CAB SHOCK ABSORBERS AND MOUNTINGS REPLACEMENT

This task covers: a. Removal b. Installation

INITIAL SETUP

Tools and Special Equipment:

Tool Kit, SC 5180-90-CL-N26

Materials/Parts:

Nut, Lock (4)

Washer, Lock (2)

Washer, Spring
Tension (2)

Washer, Lock (2)

Caps and Plugs Appendix C, Item 7

Rags Appendix C, item 32

Equipment Condition:

Reference	Condition Description
Page 4-794 or 4-546	Front Loader (SEE) or Forklift (HMMH) Removed
Page 2-23	Hydraulic Pressure Relieved

General Safety Instructions:

W A R N I N G

- SEE/HMMH should not be operated with front loader (SEE) or forklift (HMMH) removed, except in a maintenance facility. When maintenance is required and front loader or forklift is removed, never operate SEE/HMMH at speeds greater than 5 mph. Tractor stability and handling characteristics are greatly affected with either front loader or forklift removed. This could cause loss of control and injury to personnel or damage to vehicle.
- High pressure hydraulics [oil under 2450 psi (16,893 kPa)] operate this equipment. Never disconnect any hydraulic line or fitting without first dropping pressure to zero. A high pressure oil stream can pierce body and cause severe injury to personnel.
- Fuel and oil are slippery and can cause falls. To avoid injury, wipe up spilled fuel or oil with rags.

CAB SHOCK ABSORBERS AND MOUNTINGS REPLACEMENT (CONT)

REMOVAL

NOTE

Procedure is the same for both vehicles except as noted.

1. REMOVE four lock nuts (1), four capscrews (2), two washers (3), and two SHOCK ABSORBERS (4). DISCARD lock NUTS.

CAUTION

Support cab prior to removing mounts to prevent damage to equipment.

2. ON LEFT SIDE, REMOVE two bolts (5), lock washer (6), spring tension washer (7), and MOUNT (8). DISCARD lock WASHER and spring tension WASHER.
3. REMOVE foam BLOCK (9).
4. ON RIGHT SIDE, REMOVE capscrew (10), lock washer (11), spacer (12), bolt (13), spring tension washer (14), and MOUNT (15). DISCARD lock WASHER and spring tension WASHER.

NOTE

Tag supports prior to removal to aid in installation.

5. REMOVE two bolts (16), two lock washers (17), and two SUPPORTS (18). DISCARD lock WASHERS.

INSTALLATION

NOTE

Procedure is the same for both vehicles except as noted.

1. INSTALL two SUPPORTS (18), two new lock washers (17), and two bolts (16).

CAUTION

Support cab prior to installing mounts to prevent damage to equipment.

2. ON RIGHT SIDE, INSTALL MOUNT (15), new spring tension washer (14), bolt (13), spacer (12), new lock washer (11), and capscrew (10). TIGHTEN BOLT and CAPSCREW to 33 lb-ft (45 N•m).

CAB SHOCK ABSORBERS AND MOUNTINGS REPLACEMENT (CONT)

3. INSTALL foam BLOCK (9).
4. ON LEFT SIDE, INSTALL MOUNT (8), new spring tension washer (7), new lock washer (6), and two bolts (5). TIGHTEN BOLTS to 33 lb-ft (45 N•m).
5. INSTALL two SHOCK ABSORBERS (4), two washers (3), four capscrews (2), and four new lock nuts (1).

NOTE

Follow-on Maintenance:

Install front loader (SEE) or forklift (HMMH) (page 4-794 or 4-546).

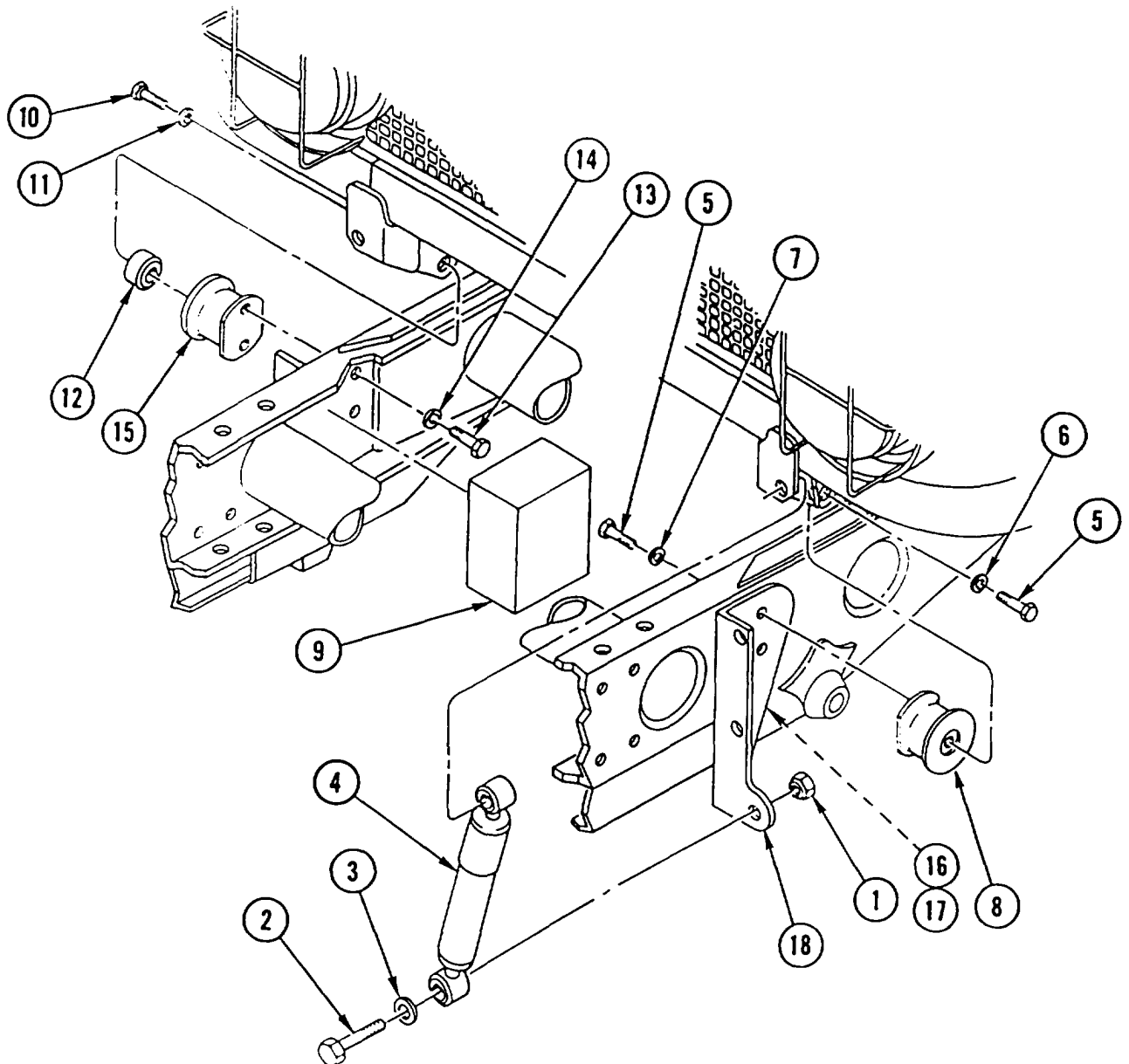

CAB TILT AND LOWER

This task covers: a. Tilt b. Lower

INITIAL SETUP

Tools and Special Equipment:

Tool Kit, SC 5180-90-CL-N26
 Tilting Device, P/N 419 580 05 51 00

Materials/Parts:

Nut
 Washer, Lock (2)
 Washer, Spring
 Tension

Personnel Required: (2)

Equipment Condition:

Reference	Condition Description
Page 4-390	Spare Tire and Mount Removed (SEE)
Page 4-391	Spare Tire and Mount Removed (HMMH)
Page 4-387	Canopy (FOPS) Removed
Page 4-388	Outside Engine Hood Removed
Page 4-389	Inside Engine Hood Removed
Page 4-794 or 4-546	Front Loader (SEE) or Foeklift (HMMH) Removed
Page 2-24	Batteries Disconnected

General Safety Instructions:

W A R N I N G

- SEE/HMMH should not be operated with front loader (SEE) or forklift (HMMH) removed, except in a maintenance facility. When maintenance is required and front loader or forklift is removed, never operate SEE/HMMH at speeds greater than 5 mph. Tractor stability and handling characteristics are greatly affected with either front loader or forklift removed. This could cause loss of control and injury to personnel or damage to vehicle.
- Cab weighs in excess of 618 pounds (281 Kilograms). Use suitable lifting device when lifting or tilting cab. Failure to do so could result in injury to personnel.

CAB TILT AND LOWER (CONT)

TILT**NOTE**

Procedure is the same for both vehicles except as noted.

1. LOOSEN CLAMP (1) and DISCONNECT air intake BELLOWS (2).

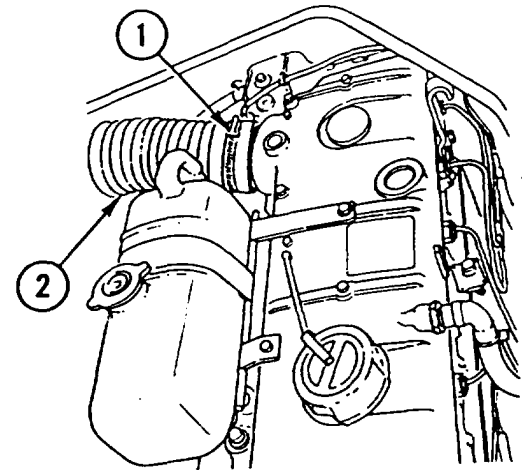
**NOTE**

Make sure front wheels are centered before performing step 2.

2. REMOVE nut (3) and SCREW (4) and DISCONNECT steering COLUMN (5) by PULLING UP on steering wheel. DISCARD NUT.

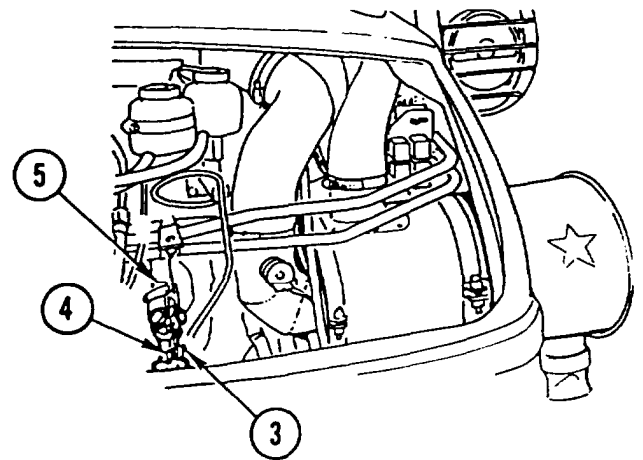

3. LOOSEN two SCREWS (6 and 7) on alternator bracket (8).
4. MOVE ALTERNATOR (9) toward engine and TIGHTEN two SCREWS (6 and 7).

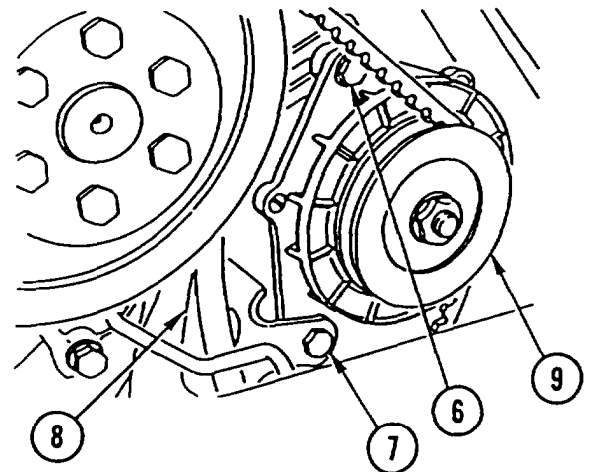

CAB TILT AND LOWER (CONT)

5. RELEASE parking BRAKE (10).

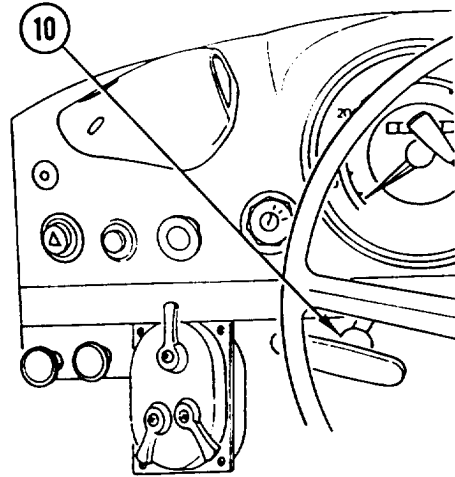

6. LOOSEN four HANDLES (11) on transmission cover (12).

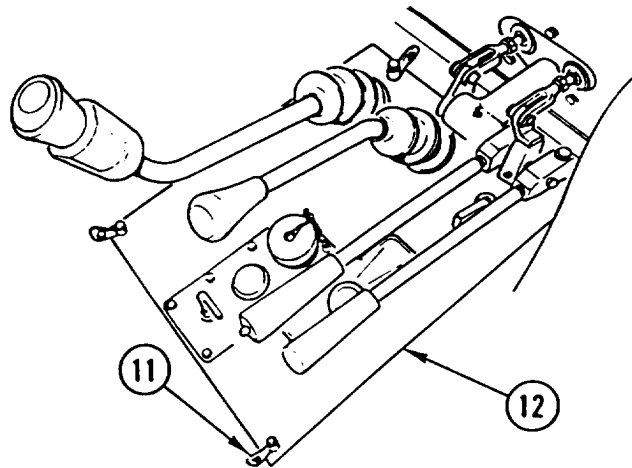

7. DISCONNECT LATCH (13) and REMOVE driver seat CUSHION (14). REPEAT for passenger seat CUSHION.

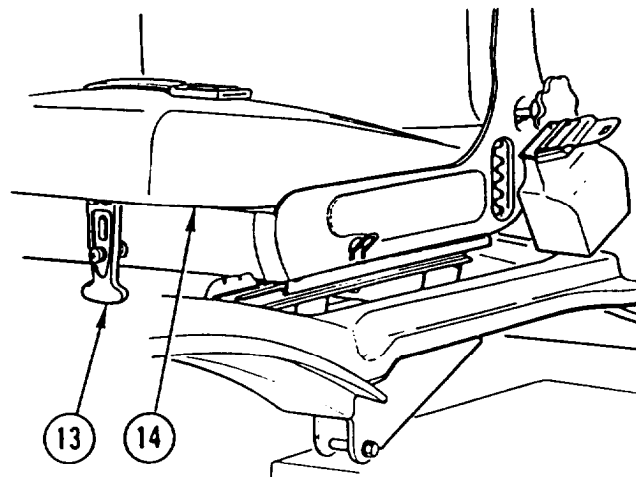

CAB TILT AND LOWER (CONT)

NOTE

Step 8 is for HMMH only.

8. DISCONNECT CONNECTOR (15)
9. REMOVE two retaining CLIPS (16), two pins (17), and two screws (18).

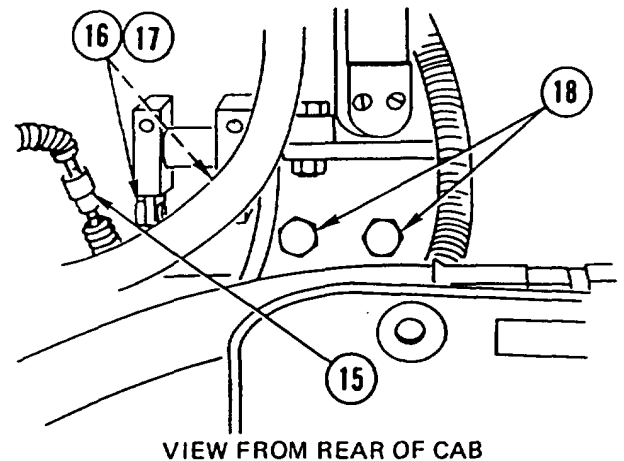

10. PRY SPRING (19) loose and SWING parking brake HOUSING (20) DOWN.

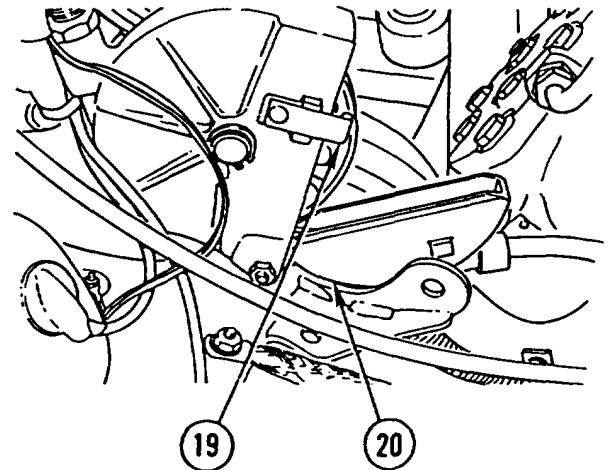

NOTE

Step 11 is for HMMH only.

11. DISCONNECT CONNECTOR (21).
12. REMOVE cab mounting screw (22), washer (23), and SPACER (24) from right cab mount (25). REPEAT for LEFT cab MOUNT.

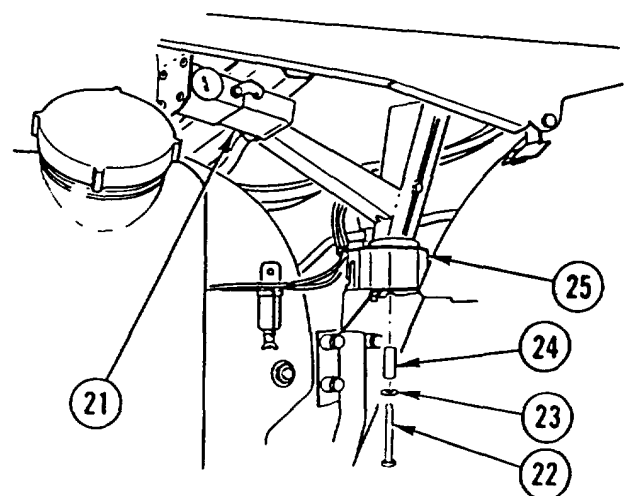

CAB TILT AND LOWER (CONT)

13. DROP left front cab shock ABSORBER (26) down by REMOVING nut (27), lock washer (28), and SCREW (29). DISCARD lock WASHER. REPEAT for RIGHT front cab shock ABSORBER.

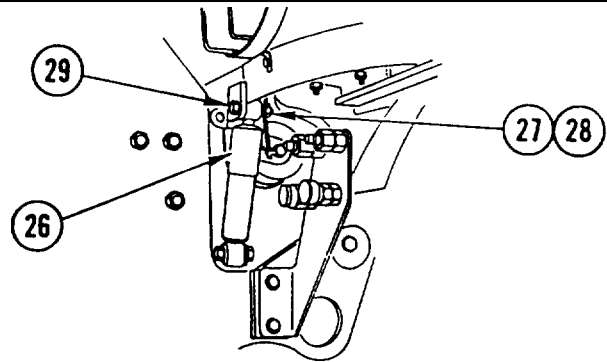

WARNING

Support cab during installation of spacers. Failure to do so could result in serious injury to personnel.

14. USING suitable LIFTING DEVICE, LIFT CAB off cab mounts and PLACE one SPACER on each side.
15. LOWER CAB onto spacers.

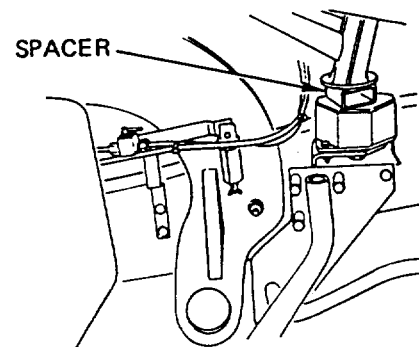
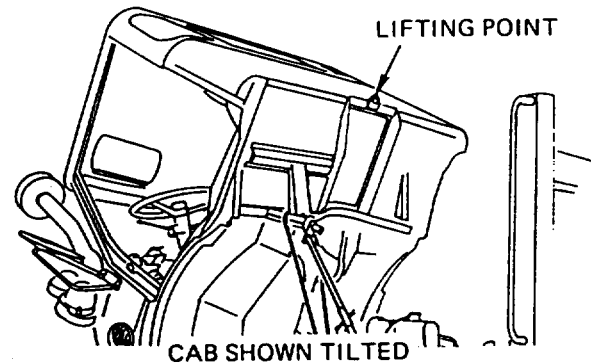

16. FROM TILTING DEVICE, ASSEMBLE cab SUPPORT.

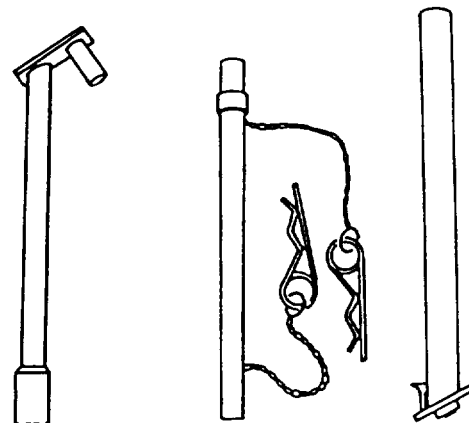

CAB TILT AND LOWER (CONT)

17. INSTALL suitable BAR through front lift points (30 and 31).

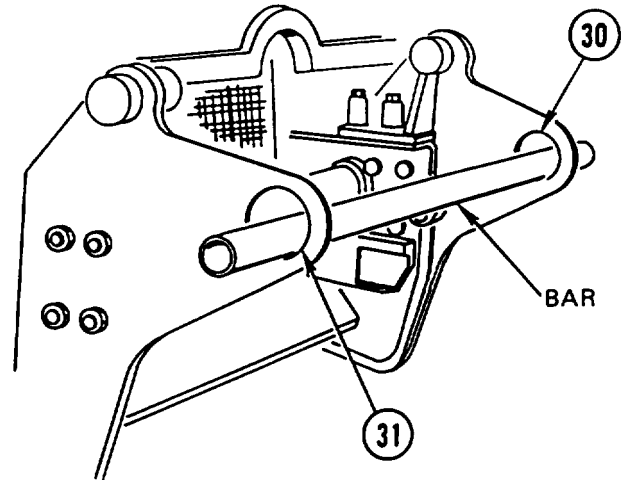

18. POSITION cab SUPPORT under front of cab (32) and on bar.

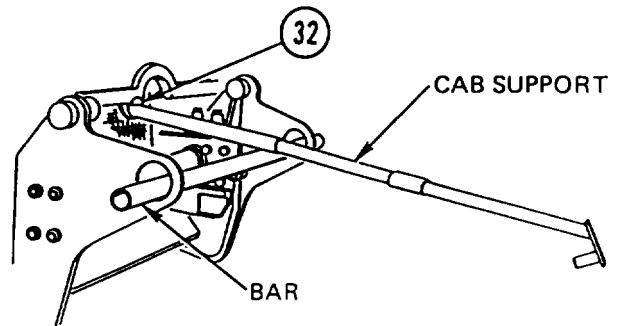

19. USING cab SUPPORT OR suitable LIFTING DEVICE, SUPPORT front of CAB and REMOVE SCREW (33) and washer (34).

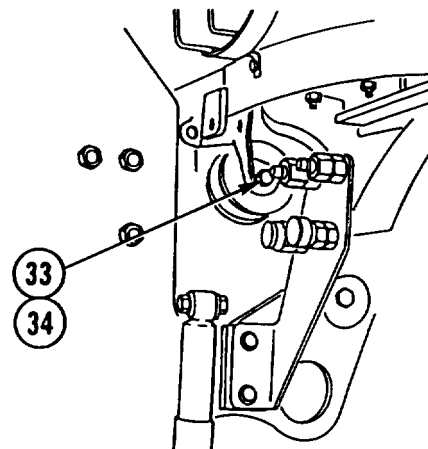

CAB TILT AND LOWER (CONT)

20. CONTINUE SUPPORTING CAB and REMOVE screw (35), spring tension washer (36), and BODY assembly (37) from right side of vehicle. DISCARD spring tension WASHER.

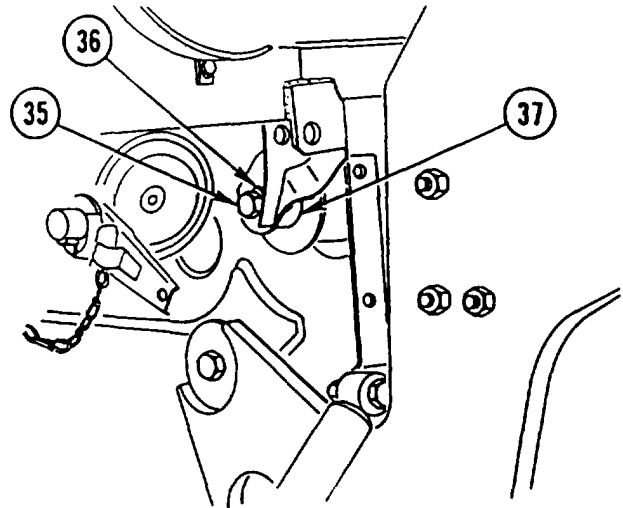

21. USING cab SUPPORT as a lever OR suitable LIFTING DEVICE, LIFT CAB as required and INSTALL mounting BRACKET, safety pin, and two bolts to left side of vehicle.

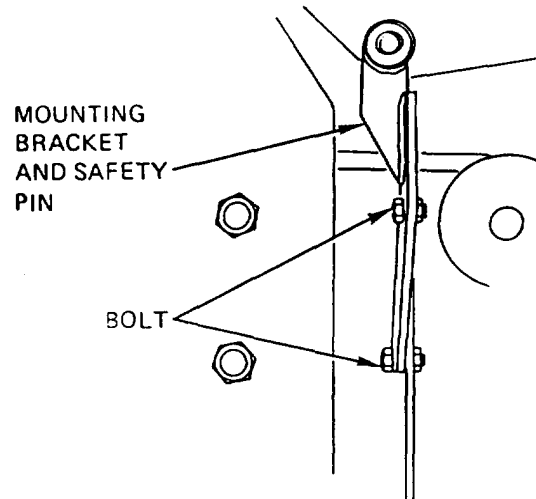

22. USING cab SUPPORT as a lever OR suitable LIFTING DEVICE, LIFT CAB as required and INSTALL mounting BRACKET, safety pin, and two bolts to right side of vehicle.

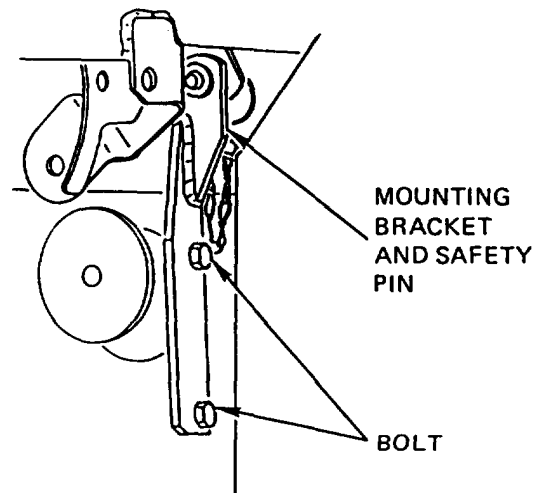

CAB TILT AND LOWER (CONT)

23. INSTALL safety CABLE through cab mount strut (38) and ATTACH ENDS to step (39) USING SHACKLE.

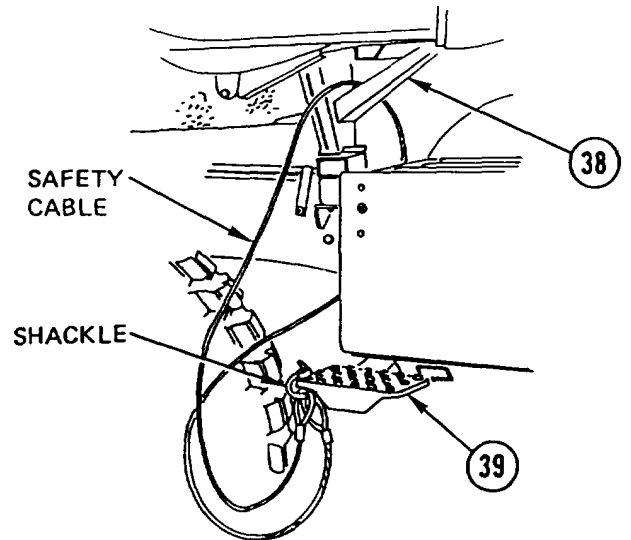

CAUTION

- Make sure cab is clear of all loose objects to prevent damage to equipment.
- Make sure fuel return line has proper clearance when tilting cab to prevent damage to equipment.

24. USING suitable LIFTING DEVICE, LIFT CAB until tilting point is reached.
25. REMOVE SPACERS installed in step 14.
26. INSTALL cab SUPPORT from step 18 using two cab mounting screws (22).
27. REMOVE BAR installed in step 17.

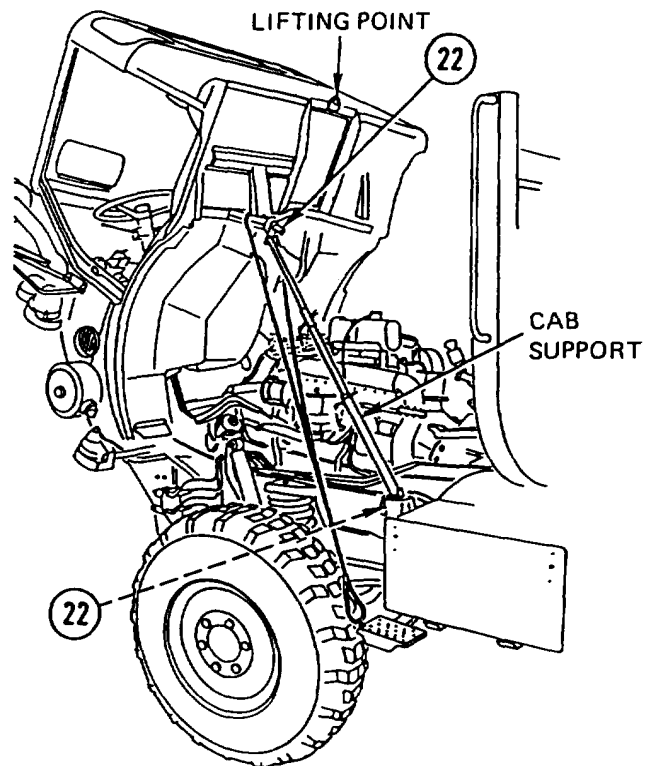

CAB TILT AND LOWER (CONT)

LOWER

NOTE

Procedure is the same for both vehicles except as noted.

1. USING suitable LIFTING DEVICE, SUPPORT weight of CAB in tilted position and REMOVE two cab mounting screws (1 and 2) and cab SUPPORT. SAVE SCREWS for installation.

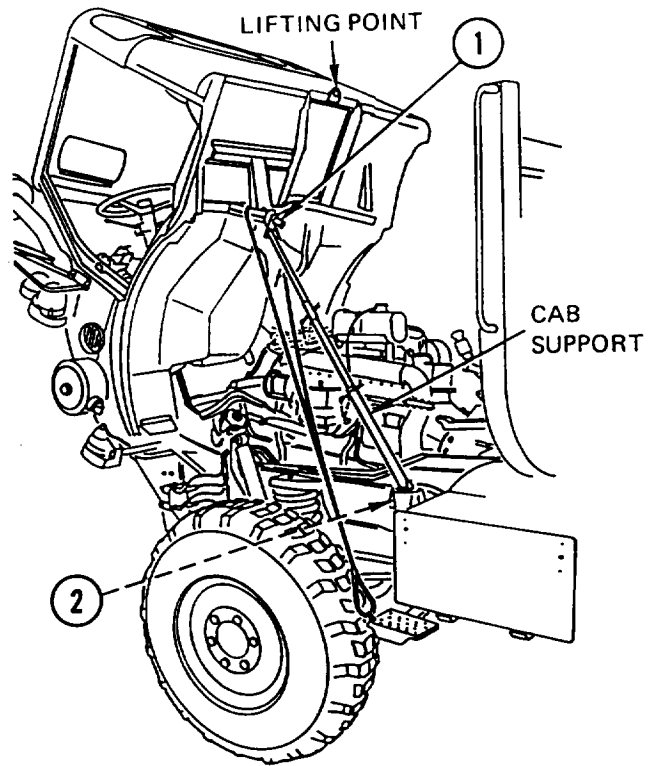

2. INSTALL one SPACER on each of two cab mounts.

CAUTION

- Make sure fuel return line has proper clearance when lowering cab to prevent damage to equipment.
- While performing step 3, have one person make sure all accessory items are clear of cab to prevent damage to equipment.

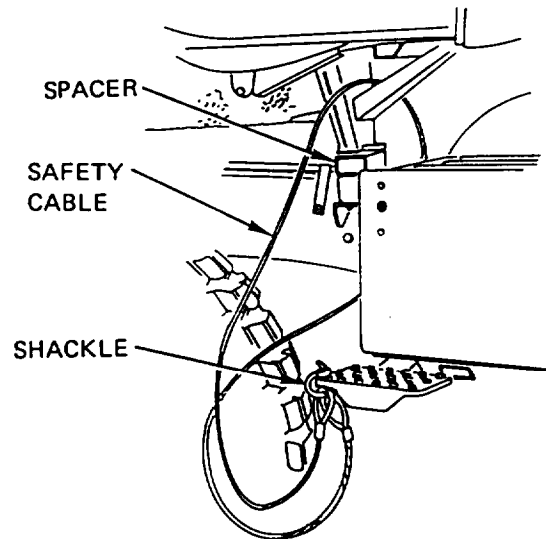

3. LOWER CAB onto spacers.
4. REMOVE safety CABLE and SHACKLE.

CAB TILT AND LOWER (CONT)

5. INSTALL suitable BAR through front lift points (3 and 4).

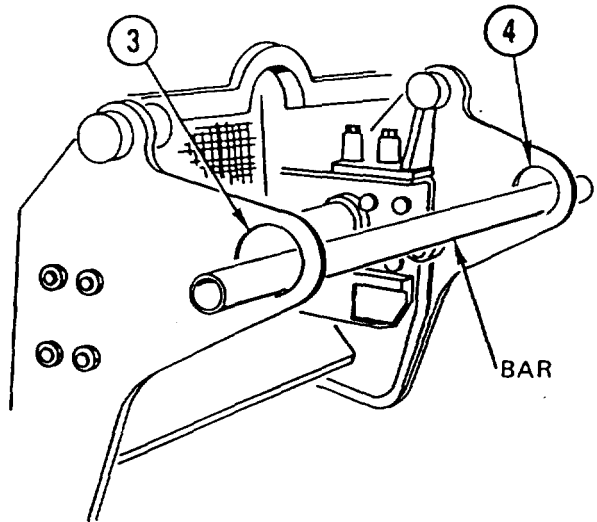

6. POSITION cab SUPPORT under front of cab (5) and on bar.

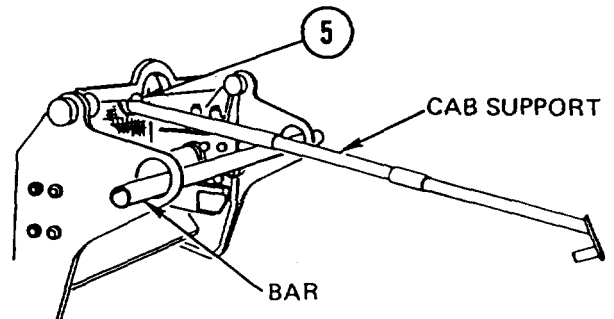

7. USING cab SUPPORT as a lever OR suitable LIFTING DEVICE, LIFT CAB as required and REMOVE mounting BRACKET, safety pin, and two bolts from right side of vehicle.

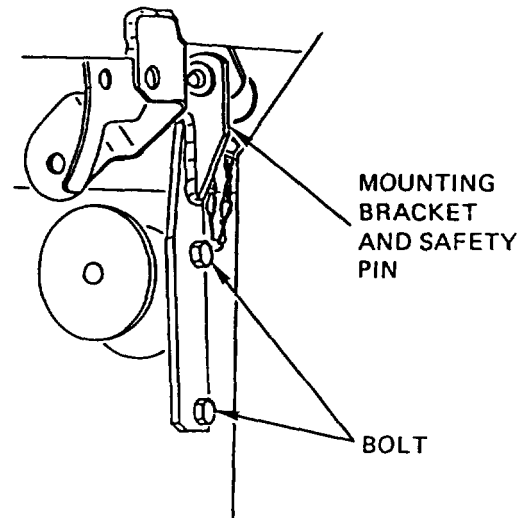

CAB TILT AND LOWER (CONT)

8. USING cab SUPPORT as a lever OR suitable LIFTING DEVICE, LIFT CAB as required and REMOVE mounting BRACKET, safety pin, and two bolts from left side of vehicle.

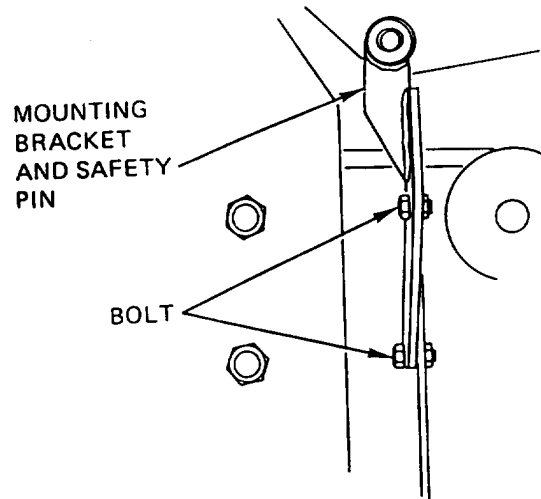

9. INSTALL screw (6), new spring tension washer (7), and BODY assembly (8). TIGHTEN SCREW to 34 lb-ft (45 N.m).

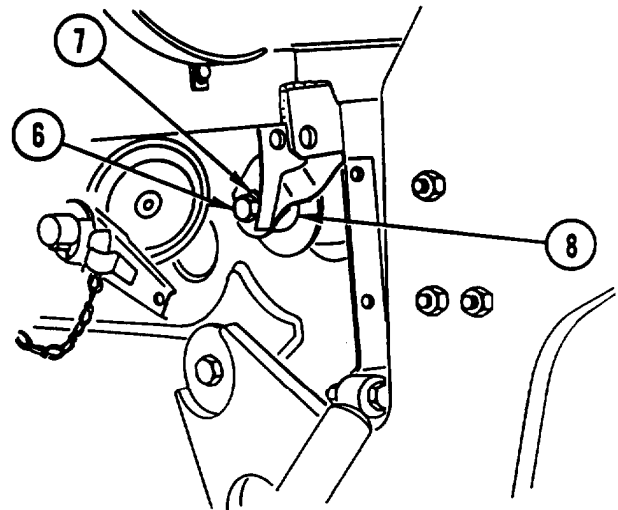

CAB TILT AND LOWER (CONT)

10. INSTALL SCREW (9) and washer (10). TIGHTEN SCREW to 34 lb-ft (45 N.m).
11. INSTALL left front cab shock ABSORBER (11) by INSTALLING SCREW (12), new lock washer (13), and nut (14). REPEAT for RIGHT front cab shock ABSORBER.

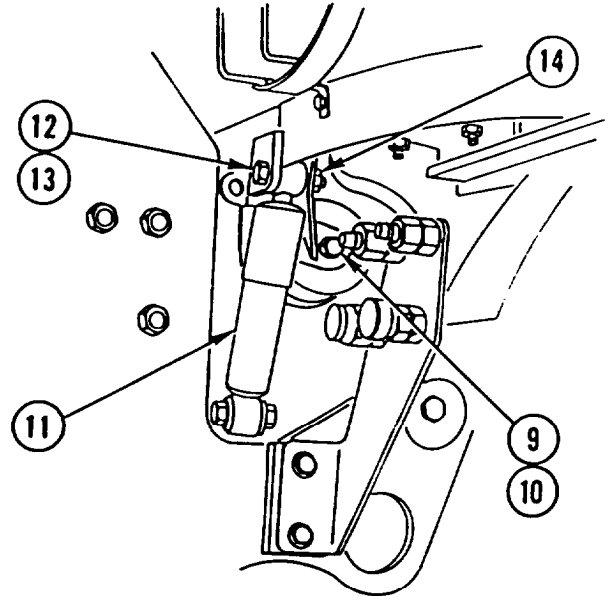

WARNING

Support cab during removal of spacers. Failure to do so could result in serious injury to personnel.

12. USING suitable LIFTING DEVICE, LIFT CAB as required and REMOVE SPACERS.
13. LOWER CAB onto cab mounts (15).

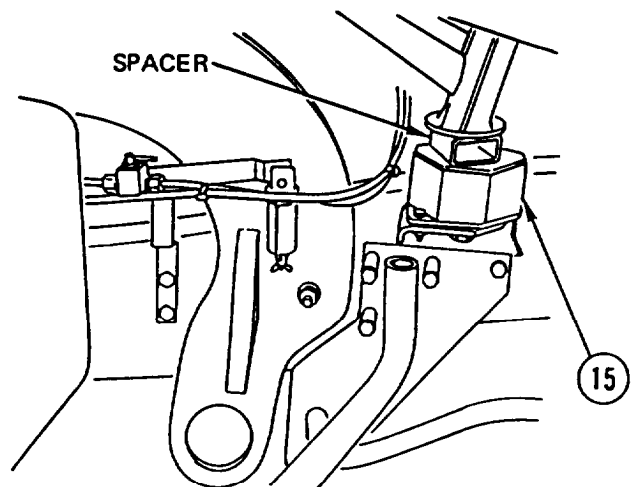

CAB TILT AND LOWER (CONT)

14. INSTALL cab mounting screw (1), washer (16), and SPACER (17) to right cab mount (18). TIGHTEN SCREW to 81 lb-ft (110 N.m). REPEAT for LEFT cab MOUNT using cab mounting screw (2).

NOTE

Step 15 is for HMMH only.

15. CONNECT CONNECTOR (19).

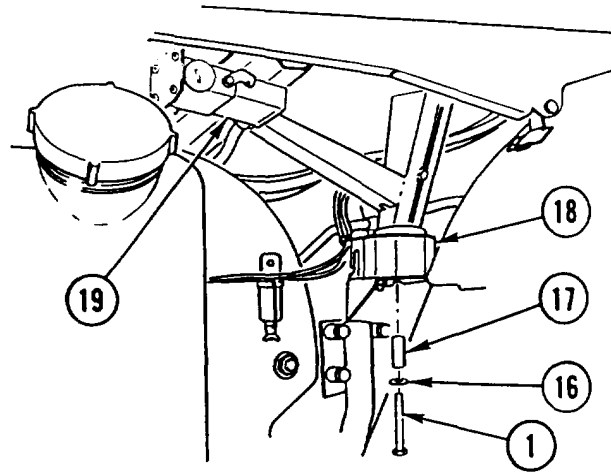

16. SWING parking brake HOUSING (20) up into spring (21).

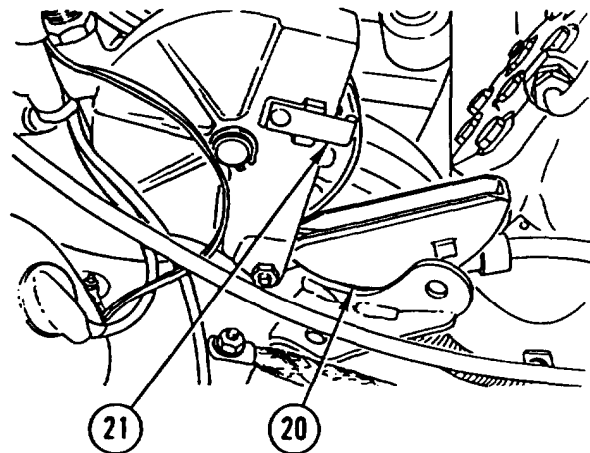

17. INSTALL two pins (22), two retaining CLIPS (23), and two screws (24).

NOTE

Step 18 is for HMMH only.

18. CONNECT CONNECTOR (25).

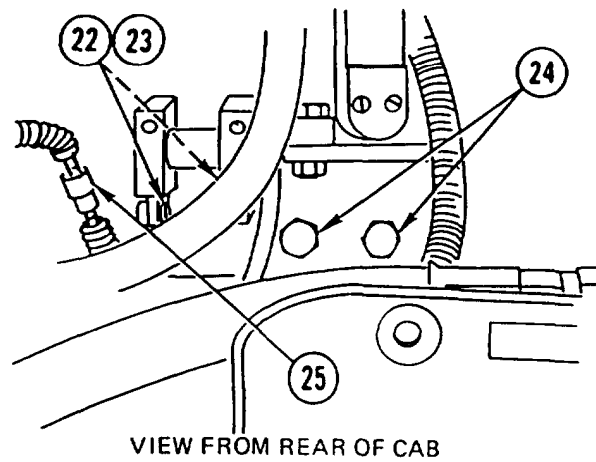

CAB TILT AND LOWER (CONT)

19. TIGHTEN four HANDLES (26) on transmission cover (27).

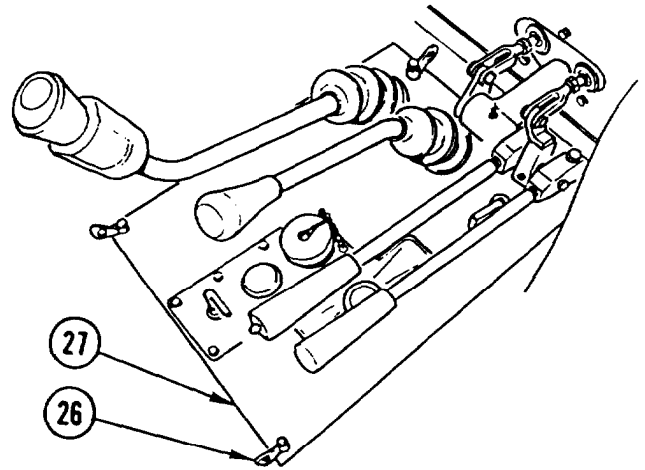

20. INSTALL driver seat CUSHION (28) and CONNECT LATCH (29). REPEAT for passenger seat CUSHION.

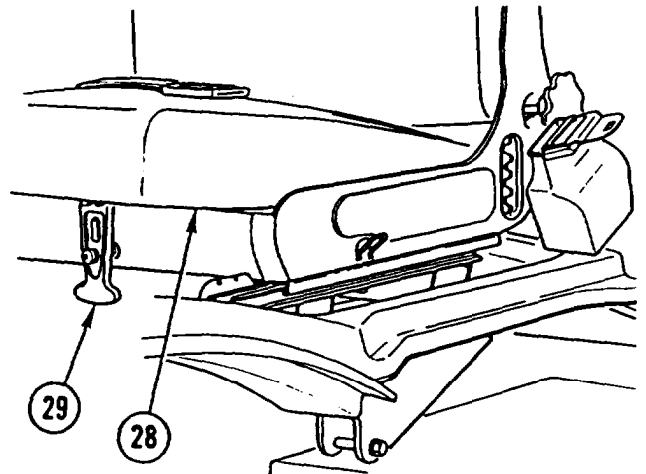

21. SET parking BRAKE (30).

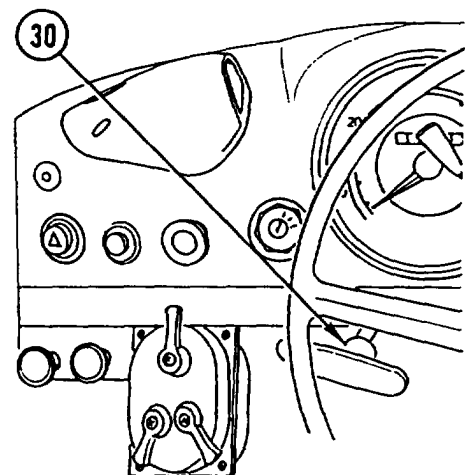

CAB TILT AND LOWER (CONT)

22. LOOSEN two SCREWS (31 and 32) and MOVE ALTERNATOR (33) outward. APPLY thumb PRESSURE on belt and CONTINUE TO TIGHTEN until bow in belt is 0.39-0.59 in. (10-15 mm).

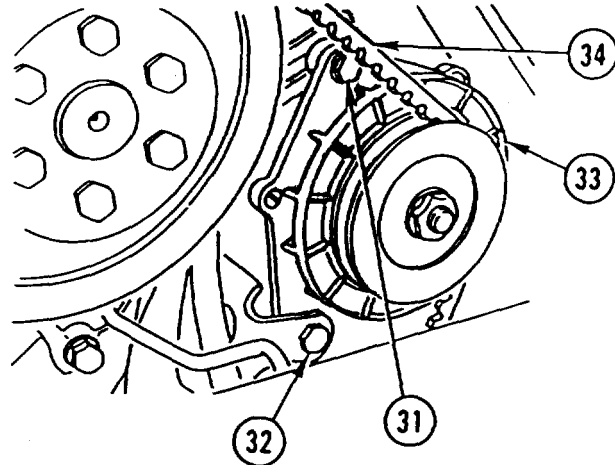

23. TIGHTEN two SCREWS (31 and 32).

NOTE

- Position screw so flat side of universal joint will prevent screw from turning.
- Make sure front wheels are centered before performing step 24.

24. CONNECT steering column universal JOINT (35) and INSTALL SCREW (36) and new nut (37). TIGHTEN to 24 lb-ft (32 N.m).

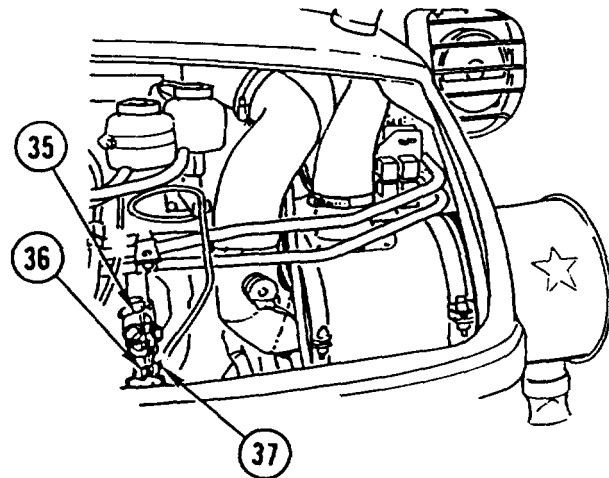

25. CONNECT air intake BELLOWS (38) and TIGHTEN CLAMP (39).

26. REMOVE cab SUPPORT installed in step 6 and BAR installed in step 5.

NOTE

Follow-on Maintenance:

- Install inside engine hood (page 4-389).
- Install outside engine hood (page 4-388).
- Install canopy (FOPS) (page 4-387).
- Install spare tire and mount (SEE) (page 4-390).
- Install spare tire and mount (HMMH) (page 4-391).
- Install front loader (SEE) or forklift (HMMH) (page 4-794 or 4-546).
- Connect batteries (page 2-24).

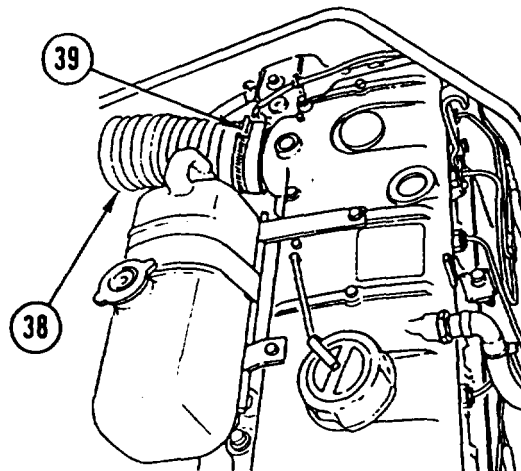

FLOOR PLATFORM REPLACEMENT

This task covers: a. Removal b. Installation

INITIAL SETUP

Tools and Special Equipment:

Tool Kit, SC 5180-90-CL-N26

Equipment Condition:

Reference	Condition Description
Page 4-418	Cab Tilted
Page 4-171	Main Disconnect Switch Removed
Page 2-23	Air Pressure Relieved

General Safety Instructions:

WARNING

Do not disconnect any air system lines or fittings unless vehicle engine is shut off and air system pressure is relieved. To do so could result in injury to personnel.

REMOVAL

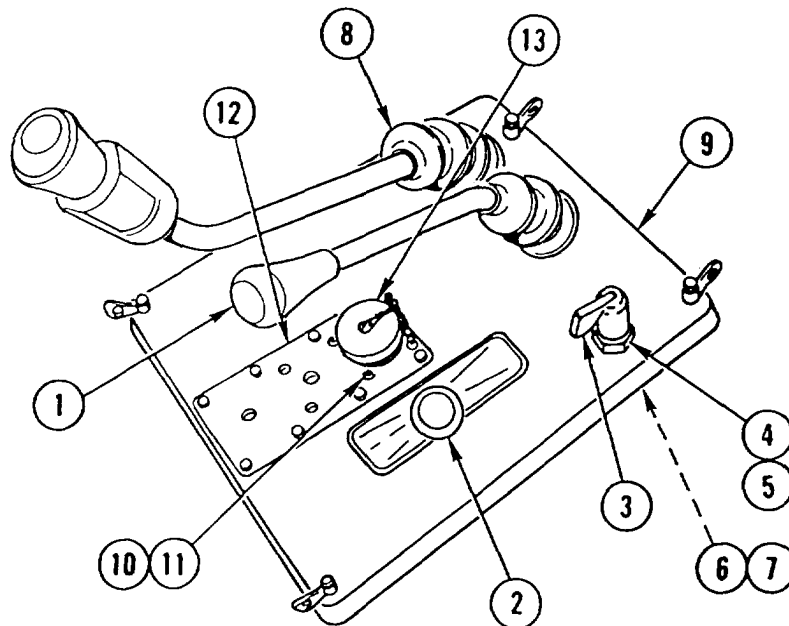

1. REMOVE two KNOBS (1 and 2) and LEVER (3).
2. REMOVE nut (4), washer (5), all wheel selector VALVE (6), and washer (7). SET all wheel selector VALVE ASIDE.
3. REMOVE BELLOWS (8) from access cover assembly (9).
4. REMOVE four nuts (10), four screws (11), and COVER (12).
5. REMOVE access COVER assembly (9) and CAREFULLY PUSH BELLOWS (8) and STE/ICE-R CONNECTOR (13) through access cover assembly (9).

FLOOR PLATFORM REPLACEMENT (CONT)

- 6. REMOVE four nuts (14), four bolts (15), and four HANDLES (16).
- 7. REMOVE COVER (17) from cover plate (18).

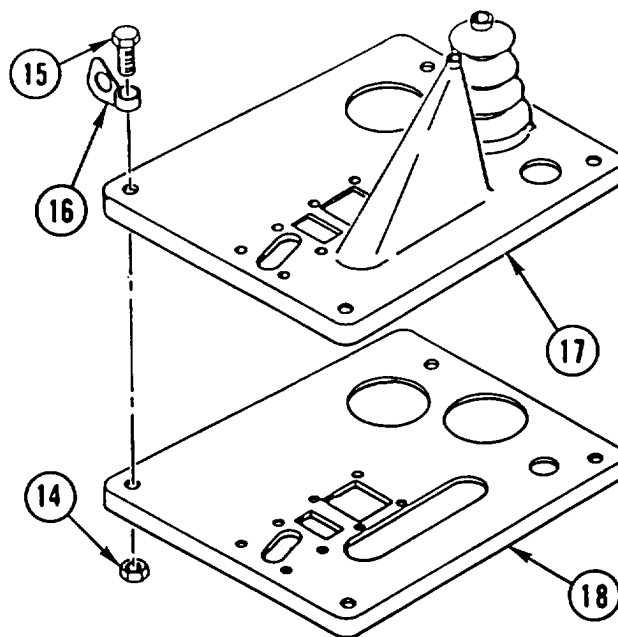

NOTE

Tag lines prior to disconnecting to aid in connecting.

- 8. IF BELLOWS (8) IS DAMAGED, DISCONNECT three air HOSES (19), LOOSEN CLAMP (20), and ROLL protective BELLOWS (21) up from transmission.

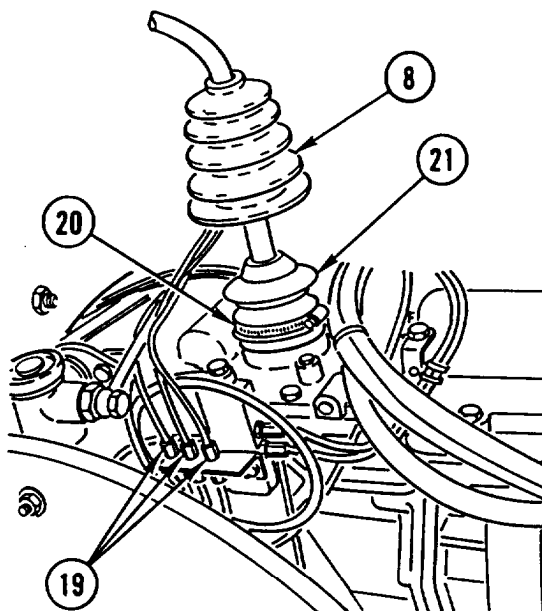

FLOOR PLATFORM REPLACEMENT (CONT)

9. ROTATE COVER (22) to unlocked position and REMOVE shift LEVER (23).
10. IF DAMAGED, REMOVE BELLOWS (8).

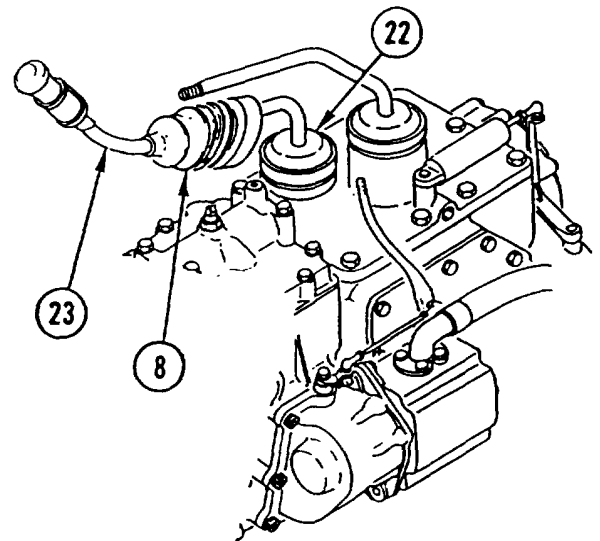
**INSTALLATION**

1. IF REMOVED, INSTALL new BELLOWS (1).
2. INSTALL shift LEVER (2) and ROTATE COVER (3) to locked position.

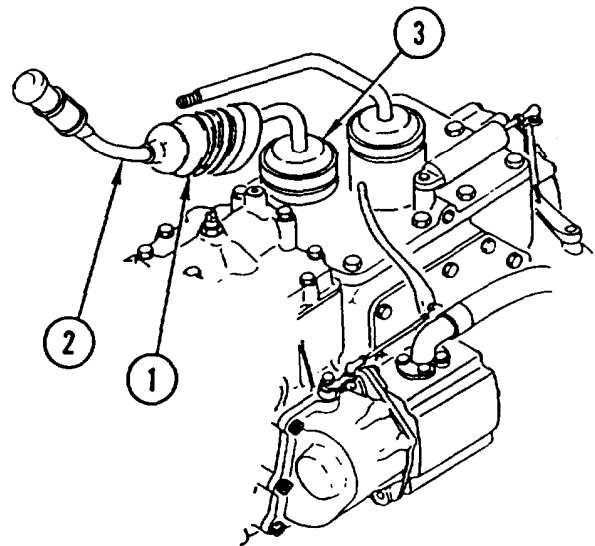

FLOOR PLATFORM REPLACEMENT (CONT)

3. IF NEW BELLOWS was installed, CAREFULLY ROLL protective BELLOWS (4) over cover (3), TIGHTEN CLAMP (5), and CONNECT three air HOSES (6).

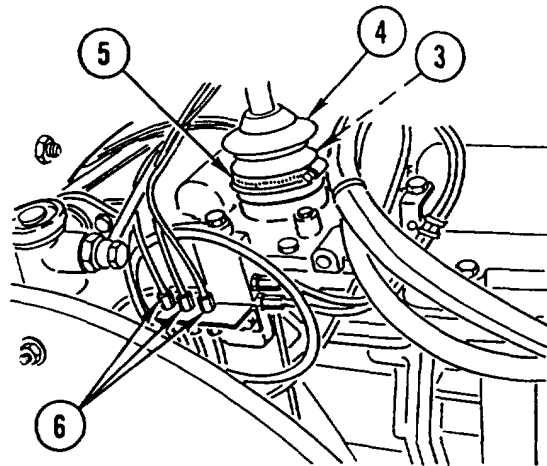

4. INSTALL COVER (7) on cover plate (8).
5. INSTALL four HANDLES (9), four bolts (10), and four nuts (11).

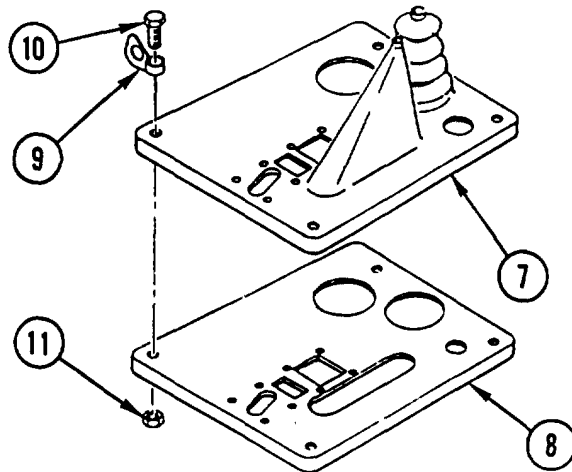

6. INSTALL access COVER assembly (12) and CAREFULLY PULL BELLOWS (1) and STE/ICE-R CONNECTOR (13) through opening.
7. INSTALL COVER (14), four screws (15), four nuts (16), and STE/ICE-R connector (13).
8. INSTALL BELLOWS (1) in access cover assembly (12).
9. INSTALL washer (17), all wheel selector VALVE (18), washer (19), and nut (20).
10. INSTALL LEVER (21) and two knobs (22 and 23).

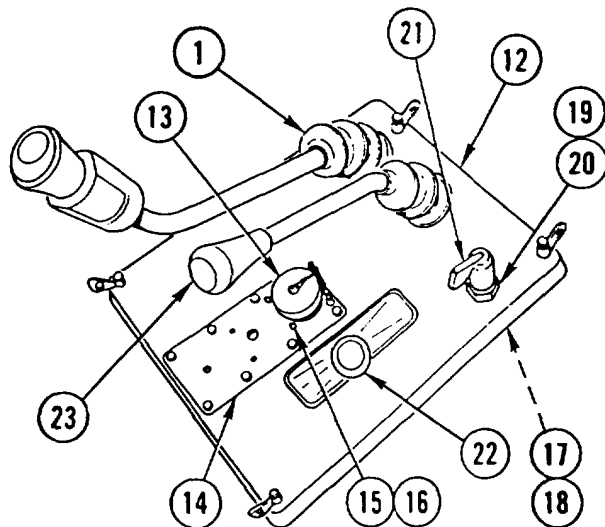

NOTE

Follow-on Maintenance:
 Install main disconnect switch
 (page 4-171).
 Lower cab (page 4-418).

OPERATOR SEAT AND FRAMEWORK REPLACEMENT

This task covers: a. Removal b. Installation

INITIAL SETUP

Tools and Special Equipment:

Tool Kit, SC 5180-90-CL-N26

Materials/Parts:

Washer, Spring Tension (4)

Screw, Lock (2)

Washer, Spring Tension (4)

Washer, Spring Tension (4)

REMOVAL

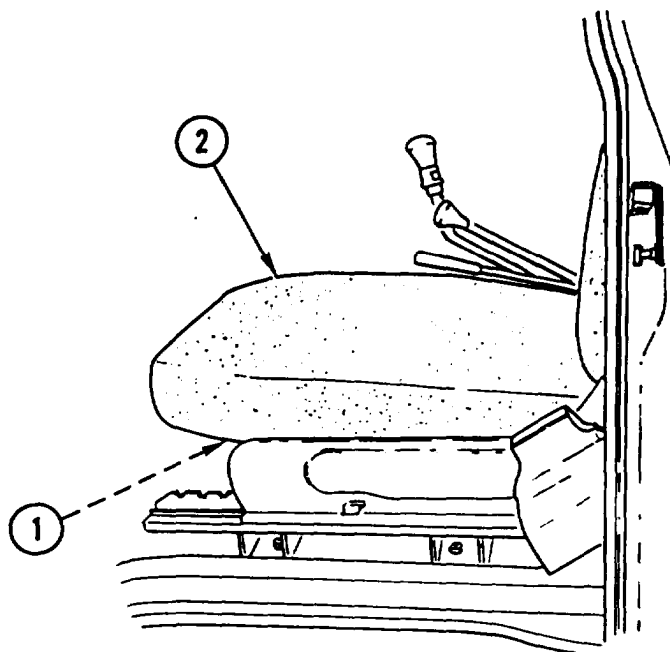

1. RELEASE LATCH (1) and REMOVE seat CUSHION (2).

OPERATOR SEAT AND FRAMEWORK REPLACEMENT (CONT)

2. REMOVE four screws (3), four spring tension washers (4), and two BRACKETS (5). DISCARD spring tension WASHERS.
3. REMOVE two screws (6), two lock screws (7), and two BRACKETS (8). DISCARD lock SCREWS.
4. REMOVE two nuts (9), two screws (10), pad (11), and LATCH (1).

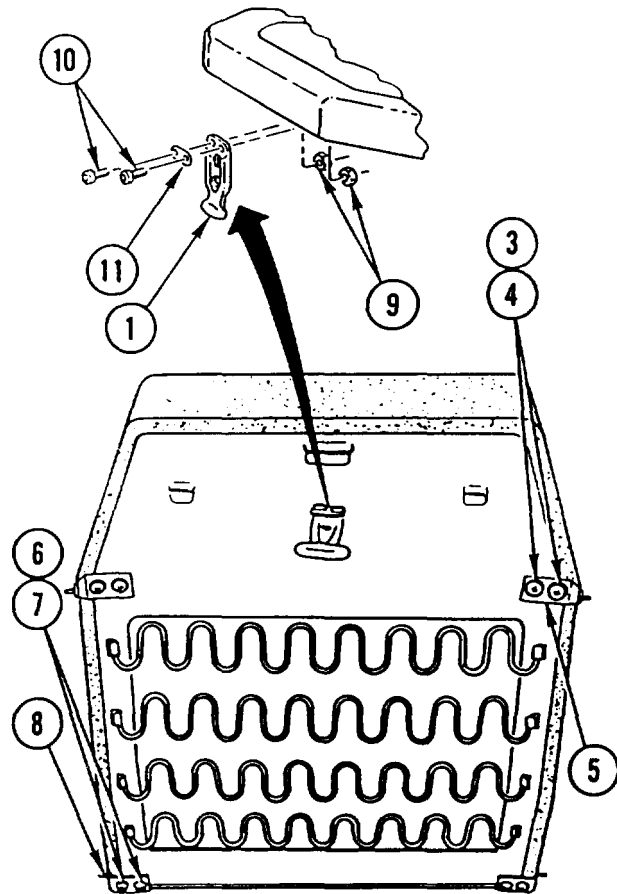

5. REMOVE four bolts (12), four spring tension washers (13), four washers (14), and seat FRAME (15). DISCARD spring tension WASHERS.

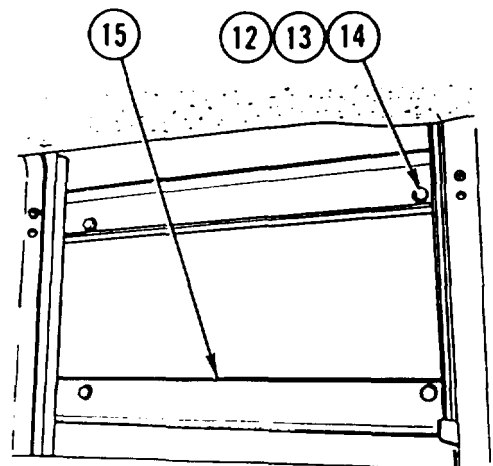

OPERATOR SEAT AND FRAMEWORK REPLACEMENT (CONT)

6. REMOVE four screws (16), four spring tension washers (17), four washers (18), bar (19), and seat back CUSHION (20). DISCARD spring tension WASHERS.

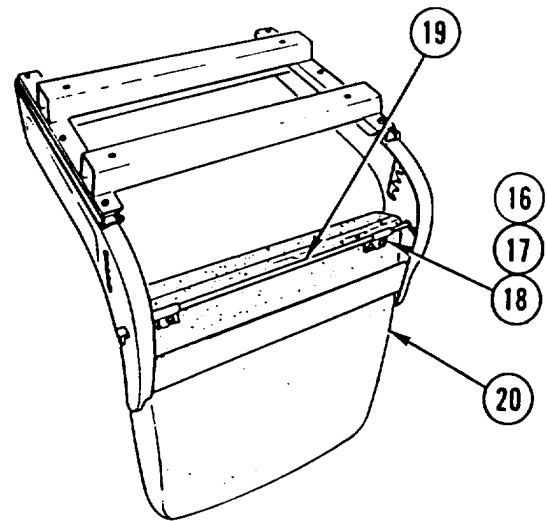

INSTALLATION

1. INSTALL seat back CUSHION (1), bar (2), four washers (3), four new spring tension washers (4), and four screws (5).

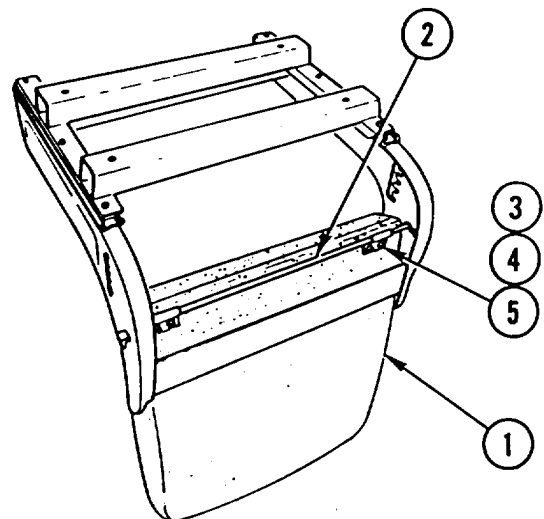

OPERATOR SEAT AND FRAMEWORK REPLACEMENT (CONT)

2. INSTALL seat FRAME (6), four washers (7), four new spring tension washers (8), and four bolts (9).

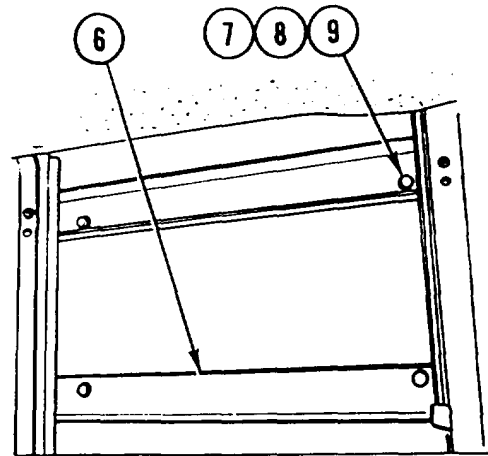

3. INSTALL LATCH (10), pad (11), two screws (12), and two nuts (13).
4. INSTALL two BRACKETS (14), two screws (15), and two new lock screws (16).
5. INSTALL two BRACKETS (17), four new spring tension washers (18), and four screws (19).

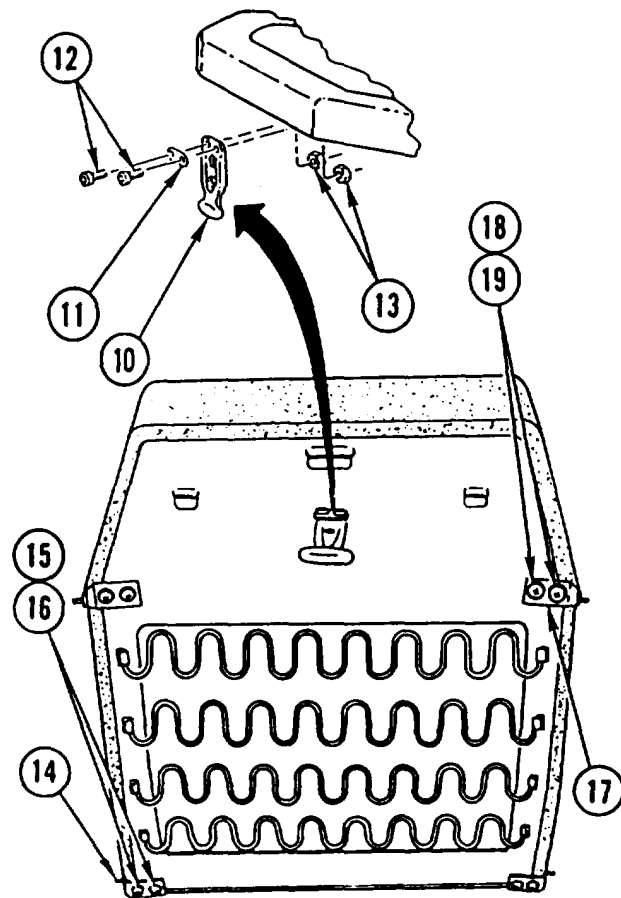

OPERATOR SEAT AND FRAMEWORK REPLACEMENT (CONT)

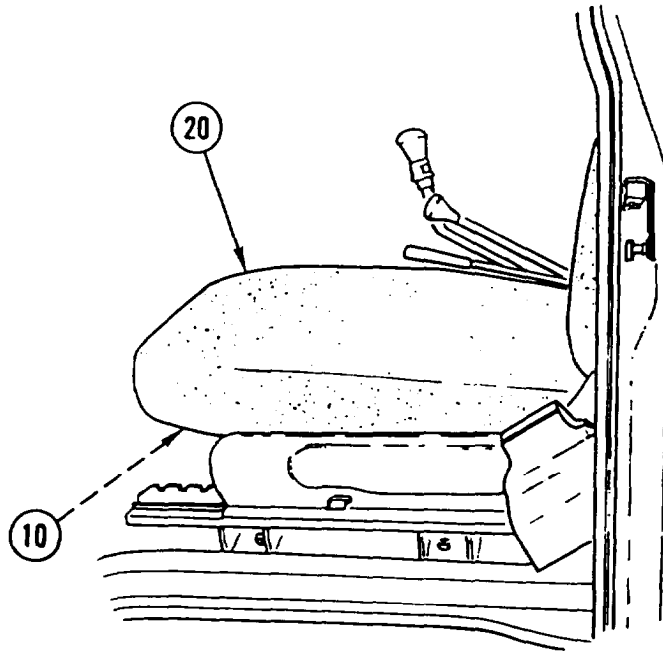

6. INSTALL seat CUSHION (20) and LATCH (10).

OPERATOR SEAT FRAMEWORK REPAIR

This task covers: a. Disassembly b. Assembly

INITIAL SETUP

Tools and Special Equipment:

Tool Kit, SC 5180-90-CL-N26

Materials/Parts:

Washer, Spring
Tension (10)

Pin

Washer, Spring
Tension

Equipment Condition:

Reference

Page 4-437

Condition Description

Operator Seat and
Framework Removed

DISASSEMBLY

1. REMOVE pin (1) and KNOB (2).
2. REMOVE BAR (3) from framework (4).
3. REMOVE four nuts (5), four screws (6), four spring tension washers (7), and FRAMEWORK (8). DISCARD spring tension WASHERS.

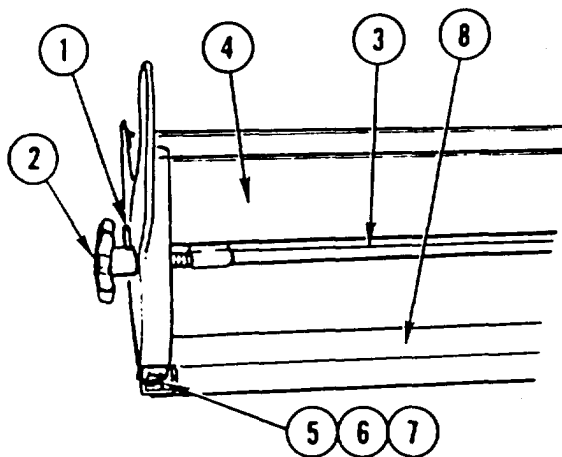

4. REMOVE six nuts (9), six screws (10), six spring tension washers (11), and two MOLDINGS (12) from framework (8).

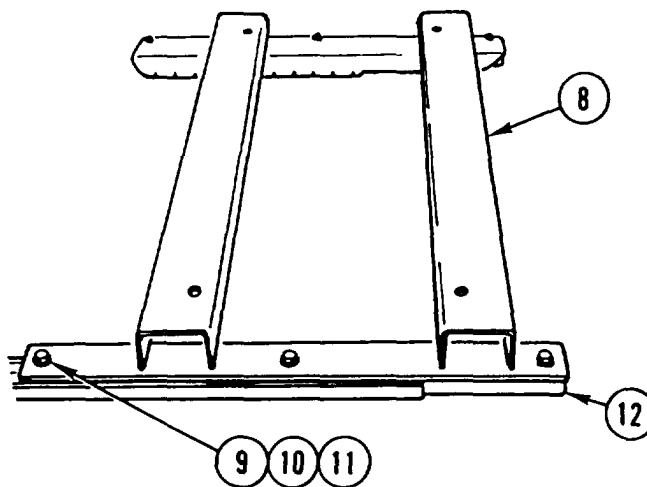

OPERATOR SEAT FRAMEWORK REPAIR (CONT)

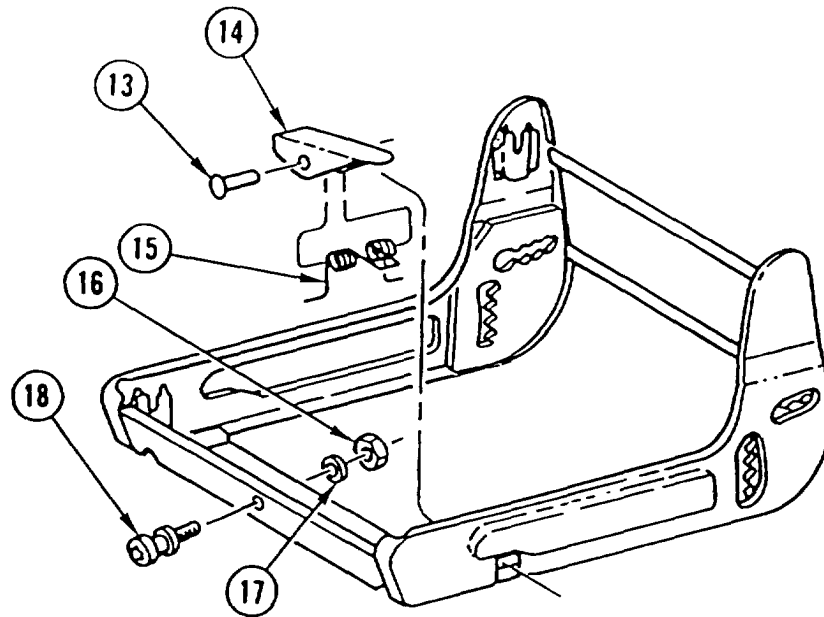

5. REMOVE pin (13), LEVER (14), and spring (15). DISCARD PIN (13).
6. REMOVE nut (16), spring tension washer (17), and SCREW (18). DISCARD spring tension WASHER.

ASSEMBLY

1. INSTALL SCREW (18), new spring tension washer (17), and nut (16).
2. INSTALL spring (15), LEVER (14), and new pin (13).
3. INSTALL two MOLDINGS (12), six new spring tension washers (11), six screws (10), and six nuts (9) to framework (8).
4. INSTALL FRAMEWORK (8), four new spring tension washers (7), four screws (6), and four nuts (5) to framework (4).
5. INSTALL BAR (3) in framework (4).
6. INSTALL KNOB (2) and pin (1).

NOTE

Follow-on Maintenance:
install operator seat and framework (page 4-437).

BACKHOE SEAT REPLACEMENT

This task covers: a. Removal b. Installation

INITIAL SETUP

Applicable Configuration:

SEE

Tools and Special Equipment:

Tool Kit, SC 5180-90-CL-N26

Equipment Condition:

Reference

Page 2-22

Condition Description

Backhoe in Three-Point
Stance

REMOVAL

REMOVE two capscrews (1) and backhoe SEAT assembly (2).

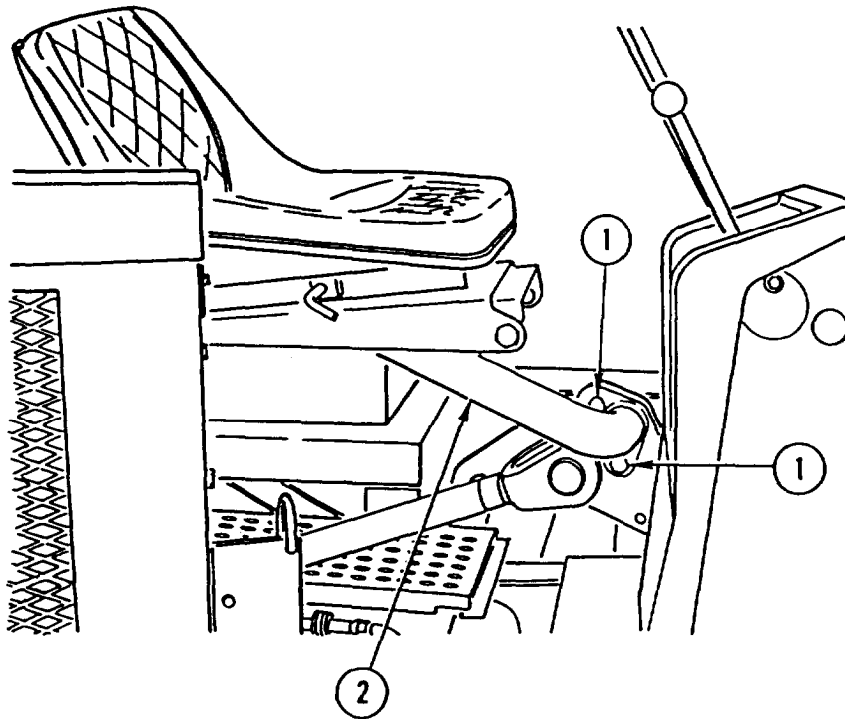

INSTALLATION

INSTALL backhoe SEAT assembly (2) and two capscrews (1).

BACKHOE SEAT REPAIR

This task covers: a. Disassembly b. Assembly

INITIAL SETUP

Applicable Configuration:

SEE

Tools and Special Equipment:

Tool Kit, SC 5180-90-CL-N26

Materials/Parts:

Washer, Lock (6)

Washer, Lock (2)

Equipment Condition:

Reference

Condition Description

Page 4-444

Backhoe Seat Removed

DISASSEMBLY

1. REMOVE two nuts (1), two lock washers (2), two bolts (3), and seat PLATE (4) from seat mounting post (5). DISCARD lock WASHERS.
2. REMOVE four nuts (6), four lock washers (7), four capscrews (8), and seat PLATE (4). Discard lock WASHERS.
3. REMOVE two nuts (9), two lock washers (10), two capscrews (11), and seat SLIDE (12). DISCARD lock WASHERS.
4. REMOVE retaining ring (13), PLUNGER (14), and spring (15) from seat (16).
5. REMOVE four screws (17) and seat CUSHION (18).

ASSEMBLY

1. INSTALL seat CUSHION (18) and four screws (17).
2. INSTALL spring (15), PLUNGER (14), and retaining ring (13) in seat (16).
3. INSTALL seat SLIDE (12), two capscrews (11), two new lock washers (10), and two nuts (9).
4. INSTALL seat PLATE (4), four capscrews (8), four new lock washers (7), and four nuts (6).
5. INSTALL seat PLATE (4), two bolts (3), two new lock washers (2), and two nuts (1) on seat mounting post (5).

NOTE

Follow-on Maintenance:
Install backhoe seat (page 4-444).

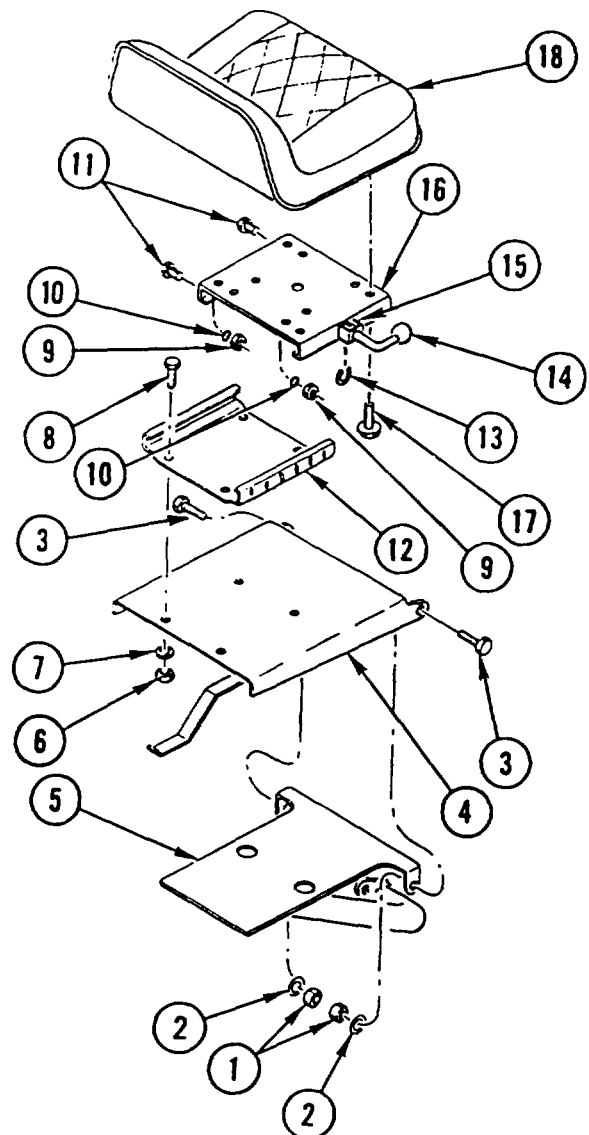

PASSENGER SEAT AND FRAMEWORK REPLACEMENT

This task covers: a. Removal b. Installation

INITIAL SETUP

Tools and Special Equipment:

Tool Kit, SC 5180-90-CL-N26

Materials/Parts:

Washer, Spring
Tension (4)

Washer, Spring
Tension (4)

Washer, Spring
Tension

Washer, Spring
Tension (4)

REMOVAL

1. RELEASE LATCH (1) and REMOVE seat COVER (2).

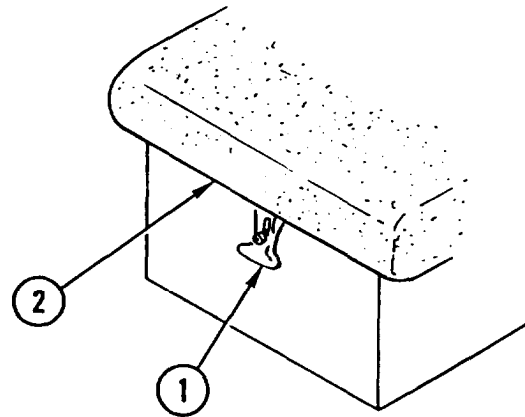

2. REMOVE four bolts (3), four washers (4), four spring tension washers (5), and seat FRAME (6). DISCARD spring tension WASHERS.

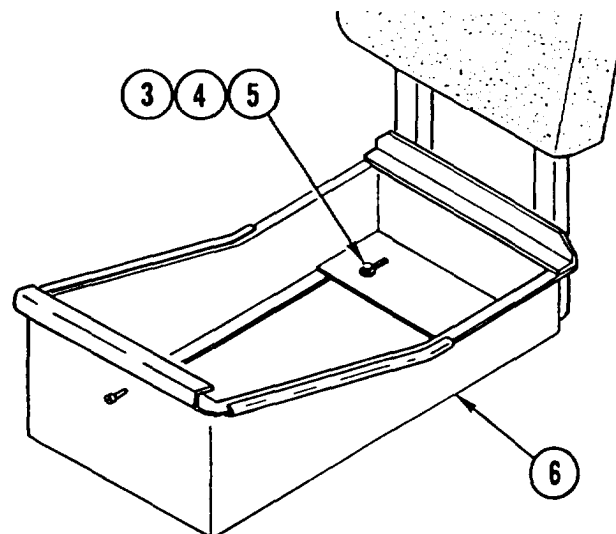

PASSENGER SEAT AND FRAMEWORK REPLACEMENT (CONT)

3. REMOVE four screws (7), four washers (8), four spring tension washers (9), and seat back CUSHION (10) from seat frame (6). DISCARD spring tension WASHERS.

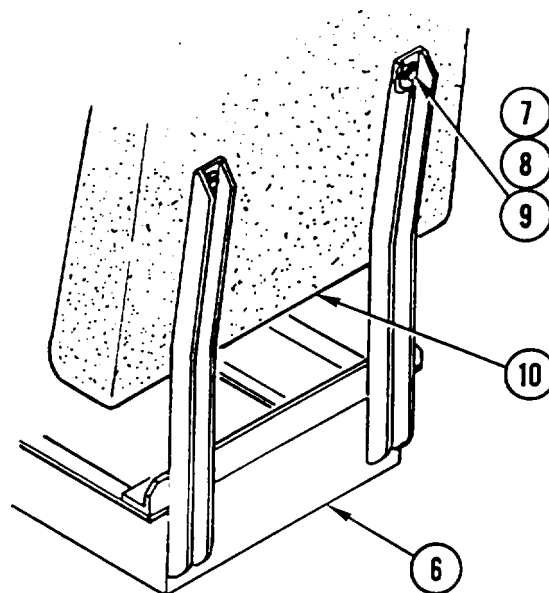

4. REMOVE nut (11), spring tension washer (12), and SCREW (13). DISCARD spring tension WASHER.
5. IF DAMAGED, REMOVE edge GUARDS (14).

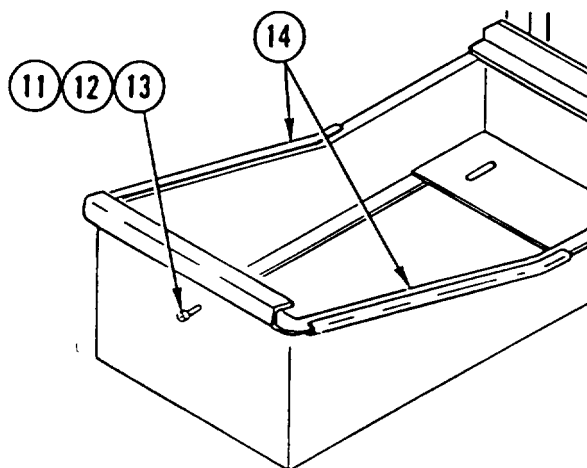

PASSENGER SEAT AND FRAMEWORK REPLACEMENT (CONT)

6. REMOVE two nuts (15), two screws (16), pad (17), and LATCH (1).
7. REMOVE four screws (18), four washers (19), four spring tension washers (20), and two PLATES (21) from seat cover (2). DISCARD spring tension WASHERS.

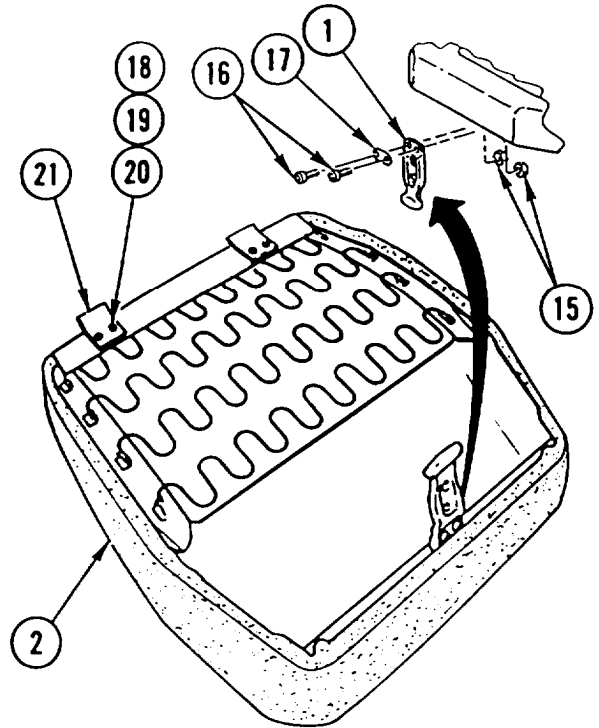

INSTALLATION

1. INSTALL two PLATES (1), four washers (2), four new spring tension washers (3), and four screws (4) on seat cover (5).
2. INSTALL LATCH (6), pad (7), two screws (8), and two nuts (9).

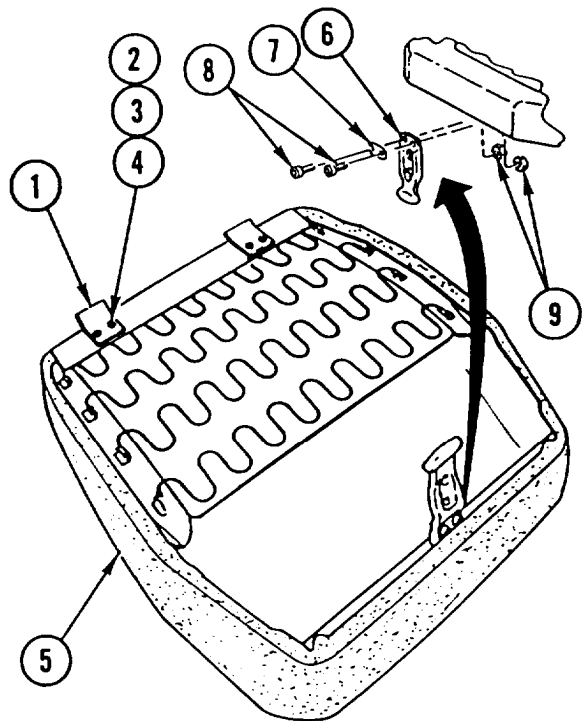

PASSENGER SEAT AND FRAMEWORK REPLACEMENT (CONT)

3. INSTALL SCREW (10), new spring tension washer (11), and nut (12).
4. IF REMOVED, INSTALL new edge GUARDS (13).

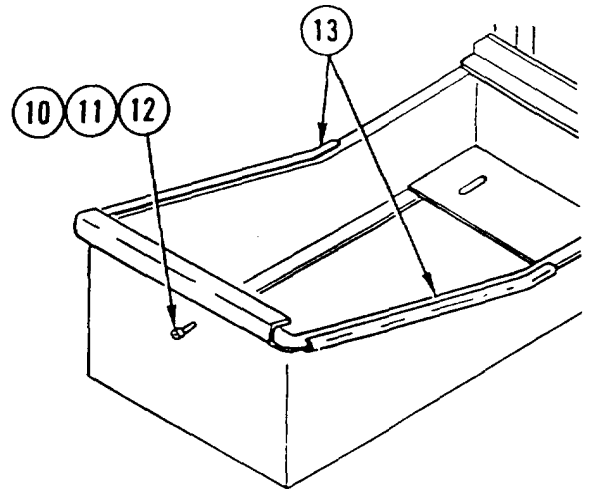

5. INSTALL seat back CUSHION (14), four new spring tension washers (15), four washers (16), and four screws (17) on seat frame (18).

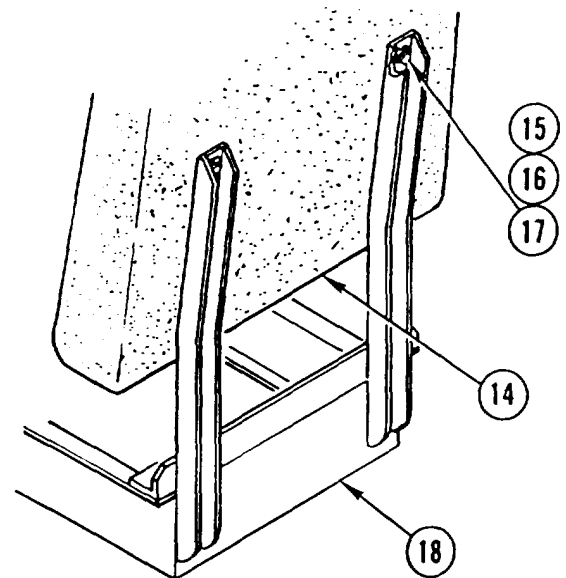

PASSENGER SEAT AND FRAMEWORK REPLACEMENT (CONT)

6. INSTALL seat FRAME (18), four washers (19), four new spring tension washers (20), and four bolts (21).

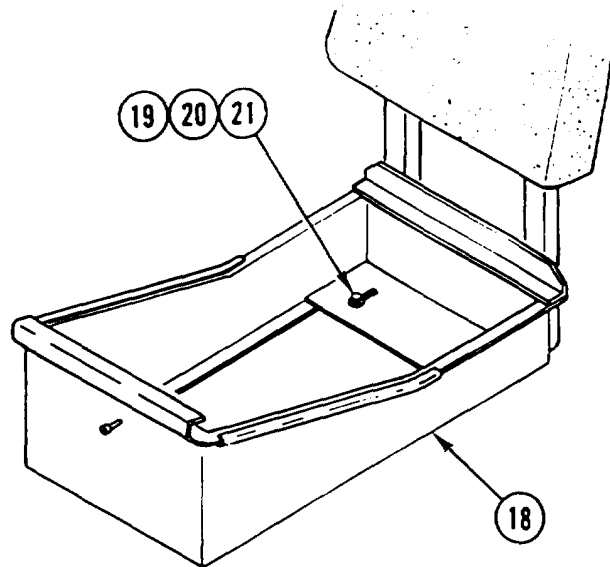

7. INSTALL seat COVER (5) and ATTACH LATCH (6).

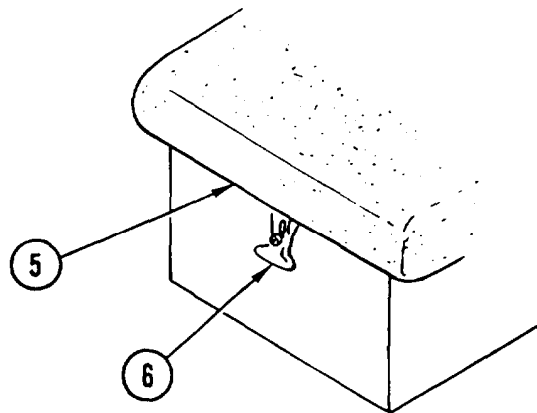

SEAT BELT REPLACEMENT

This task covers: a. Removal b. Installation

INITIAL SETUP

Tools and Special Equipment:

Tool Kit, SC 5180-90-CL-N26

Materials/Parts:

Washer, Lock (2)

REMOVAL

NOTE

Procedure is the same for both seat belts.

1. REMOVE screw (1), washer (2), and seat BELT (3).

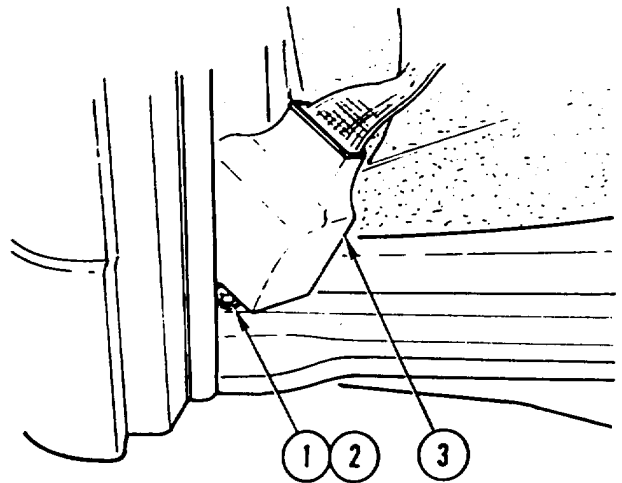

2. REMOVE nut (4), screw (5), washer (6), and seat BELT (7).

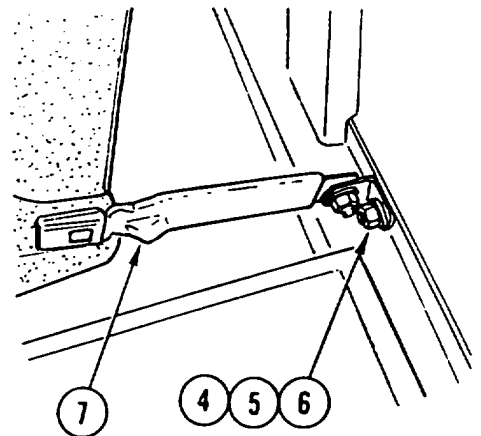

SEAT BELT REPLACEMENT (CONT)

3. REMOVE nut (8), lock washer(9), screw (10), washer (11), and BRACKET (12) from seat belt (3). DISCARD lock WASHER.

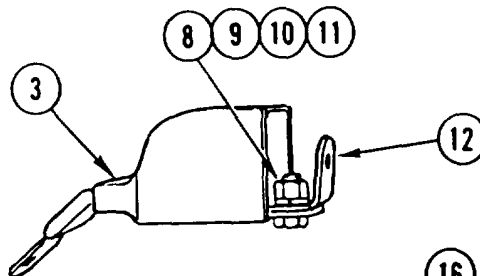

4. REMOVE nut (13), lock washer (14), screw (15), and BRACKET (16) from seat belt (7). DISCARD lock WASHER.

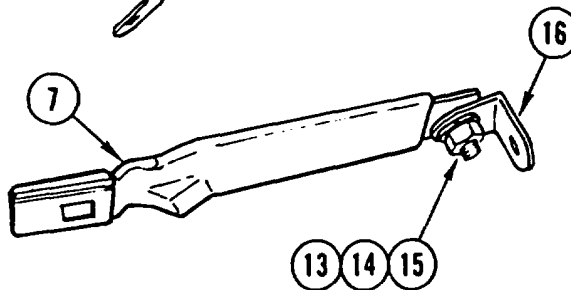

INSTALLATION

NOTE

Procedure is the same for both seat belts.

1. INSTALL BRACKET (1), screw (2), new lock washer (3), and nut (4) on seat belt (5).

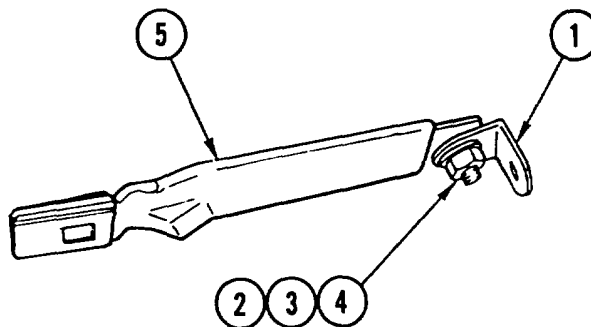

2. INSTALL BRACKET (6), washer (7), screw (8), new lock washer (9), and nut (10) on seat belt (11).

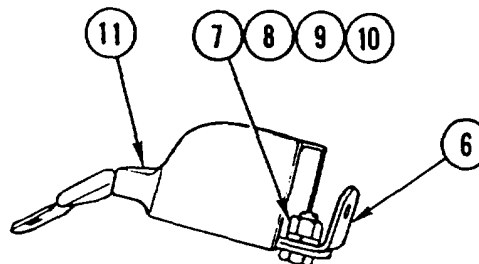

SEAT BELT REPLACEMENT (CONT)

3. INSTALL seat BELT (5), washer (12), screw (13), and nut (14). TIGHTEN SCREW to 40 lb-ft (54 N.m).

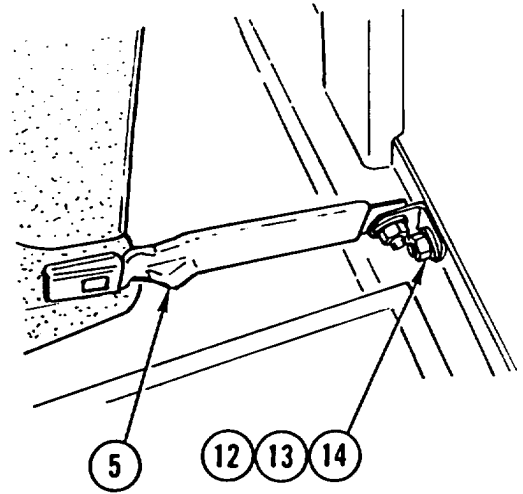

4. INSTALL seat BELT (11), washer (15), and screw (16). TIGHTEN SCREW to 40 lb-ft (54 N.m).

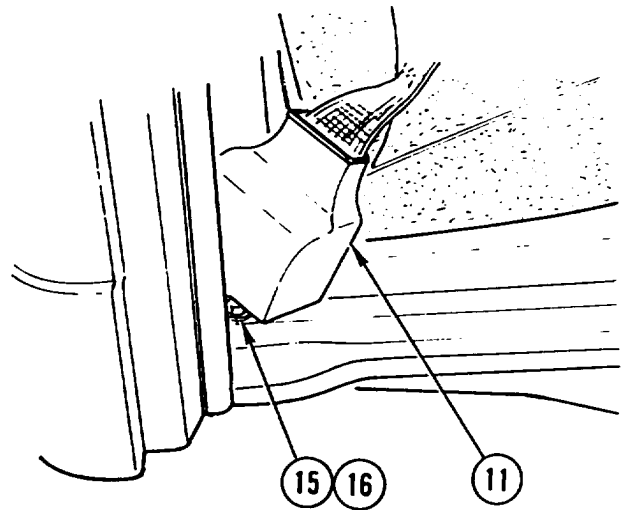

CAB FLOOR LININGS REPLACEMENT

This task covers: a. Removal b. Installation

INITIAL SETUP

Tools and Special Equipment:

Tool Kit, SC 5180-90-CL-N26

Materials/Parts:

Adhesive, Rubber

Appendix C, Item 3

REMOVAL

REMOVE and DISCARD floor LINING(S) (1, 2, 3, 4).

INSTALLATION

WARNING

Adhesive causes immediate bonding on contact with eyes, skin, or clothing and also gives off harmful vapors. Wear protective goggles and use in well-ventilated area. If adhesive gets in eyes, try to keep eyes open; flush eyes with water for 15 minutes and get immediate medical attention.

CAUTION

Make sure all old adhesive has been removed from cab floor lining surfaces to prevent damage to equipment.

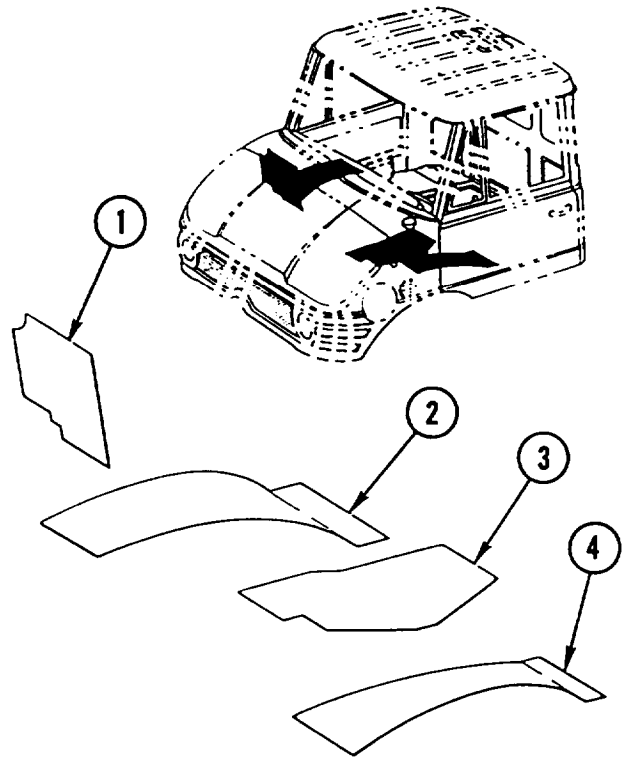

1. APPLY liberal COAT of RUBBER ADHESIVE to new floor LINING(S) (1, 2, 3, 4).
2. INSTALL floor LINING(S) (1, 2, 3, 4).

SUN VISOR, CLOTHES HOOK, AND GRIP HANDLES REPLACEMENT

This task covers: a. Removal b. Installation

INITIAL SETUP

Tools and Special Equipment:

Tool Kit, SC 5180-90 -C L-N26

Materials/Parts:

Washer, Lock (3)

REMOVAL

NOTE

Procedure is the same for both sun visors.

1. REMOVE three screws (1), three lock washers (2), and sun VISOR (3). DISCARD lock WASHERS.

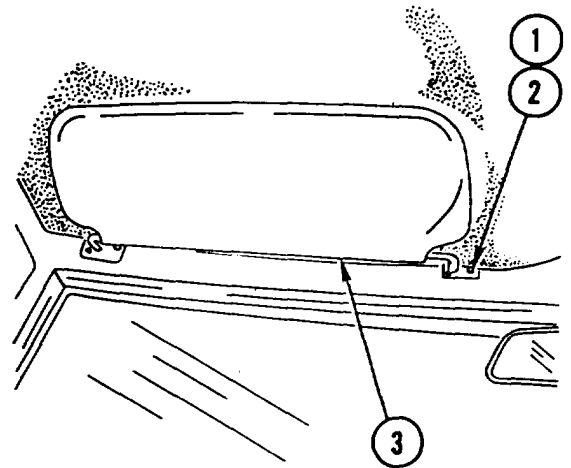

NOTE

Procedure is the same for both clothes hooks.

2. REMOVE two screws (4) and clothes HOOK (5).

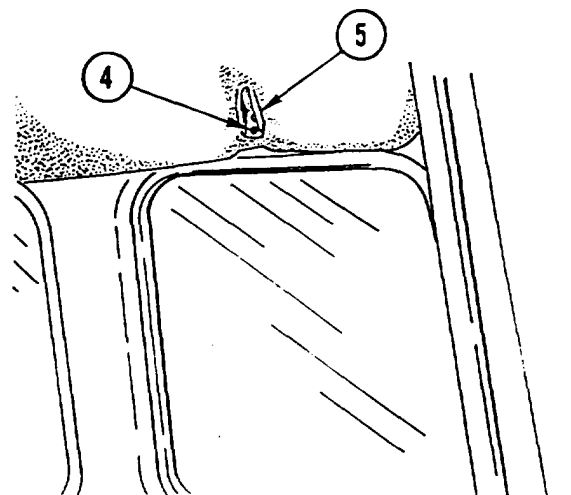

SUN VISOR, CLOTHES HOOK, AND GRIP HANDLES REPLACEMENT (CONT)

3. REMOVE two screws (6) and grip HANDLE (7).
4. REMOVE four screws (8) and grip HANDLE (9).

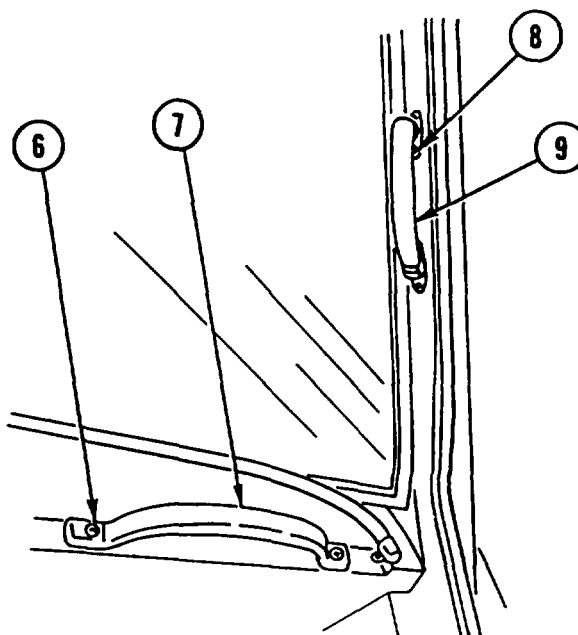

INSTALLATION

1. INSTALL grip HANDLE (1) and four screws (2).
2. INSTALL grip HANDLE (3) and two screws (4).

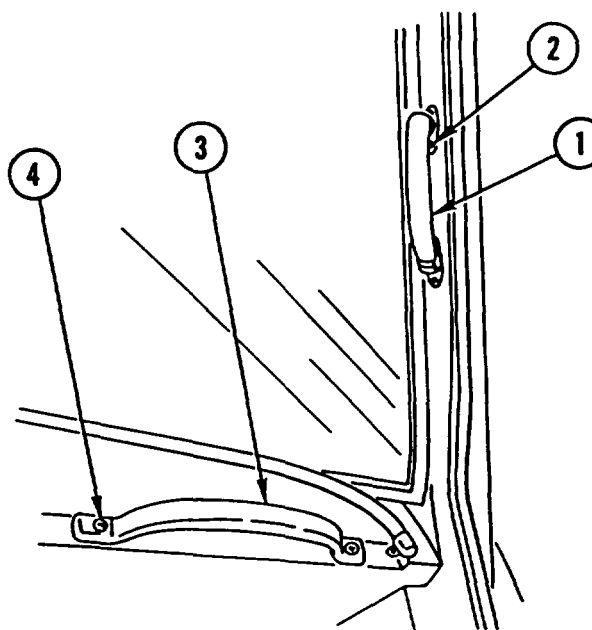

**SUN VISOR, CLOTHES HOOK, AND GRIP HANDLES REPLACEMENT
(CONT)**

NOTE

Procedure is the same for both clothes hooks.

3. INSTALL clothes HOOK (5) and two screws (6).

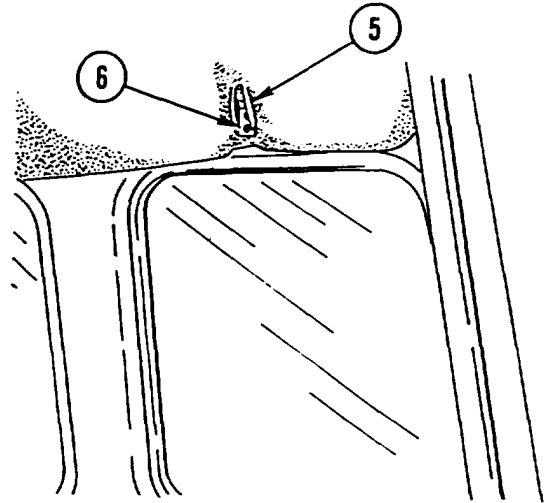

NOTE

Procedure is the same for both sun visors.

4. INSTALL sun VISOR (7), three screws (8), and three new lock washers (9).

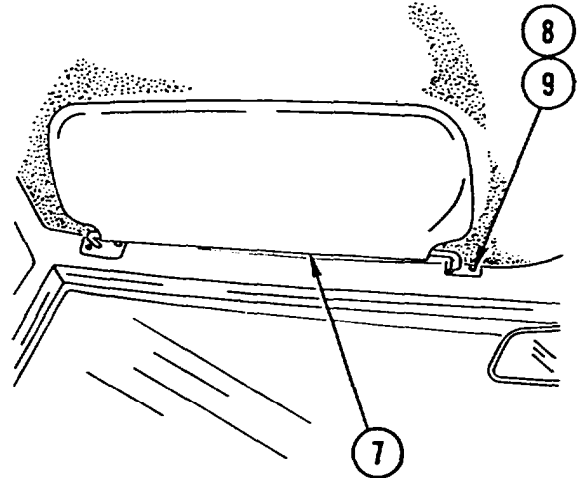

ROOF LINER REPLACEMENT

This task covers: a. Removal b. Installation

INITIAL SETUP

Tools and Special Equipment:

Tool Kit, SC 5180-90 -CL-N26

Materials/Parts:

Rivet (7)

Equipment Condition:

Reference

Page 4-455

Condition Description

Sun Visor, Clothes Hook,
and Grip Handles
Removed

REMOVAL

1. REMOVE rivet (1) and rear PANELING (2). DISCARD RIVET.
2. REMOVE four rivets (3) and FRAME (4). DISCARD RIVETS.
3. REMOVE two rivets (5) and roof PANELING (6). DISCARD RIVETS.

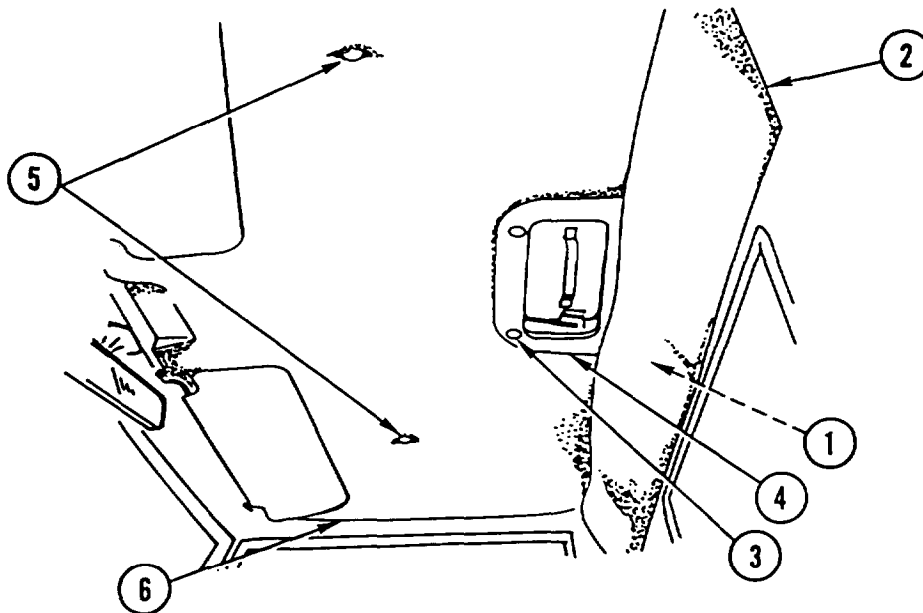

INSTALLATION

1. INSTALL roof PANELING (6) and two new rivets (5).
2. INSTALL FRAME (4) and four new rivets (3).
3. INSTALL rear PANELING (2) and new rivet (1).

NOTE

Follow-on Maintenance:
Install sun visor, clothes hook, and grip handles (page 4-455).

HOSE REEL ASSEMBLY REPLACEMENT AND REPAIR

This task covers: a. Removal b. Disassembly c. Inspection d. Assembly e. Installation

INITIAL SETUP

Tools and Special Equipment:

Shop Equipment, SC 4910-95-CL-A74
 Tool Kit, SC 5180-90-CL-N26

Materials/Parts:

Nut, Lock (2)
 Pin, Cotter (2)
 Caps and Plugs Appendix C, Item 7
 Rags Appendix C, Item 32

Personnel Required: (2)

References:

TM 9-214

Equipment Condition:

Reference	Condition Description
Page 4-471	Hydraulic Tool Hoses Removed
Page 4-464	Hose Reel Motor Spring Removed

General Safety Instructions:

WARNING

- . High pressure hydraulics [oil under 2450 psi (16,893 kPa)] operate this equipment. Never disconnect any hydraulic line or fitting without first dropping pressure to zero. A high pressure oil stream can pierce body and cause severe injury to personnel.
- . Hose reel assembly weighs 125 pounds (57 kilograms). To avoid personal injury, use a hoist or suitable lifting device when lifting hose reel assembly.
- . Fuel and oil are slippery and can cause falls. To avoid injury, wipe up spilled fuel or oil with rags.

HOSE REEL ASSEMBLY REPLACEMENT AND REPAIR (CONT)

REMOVAL

CAUTION

Cap or plug all ports and ends of hoses and tubes to prevent contamination of hydraulic oil. Failure to do so may result in damage to equipment.

NOTE

Tag lines prior to disconnecting to aid in connecting.

1. DISCONNECT two HOSES (1 and 2). INSTALL CAPS or PLUGS.
2. REMOVE two bolts (3) and BRACKET (4).
3. REMOVE four screws (5) and FRAME (6).

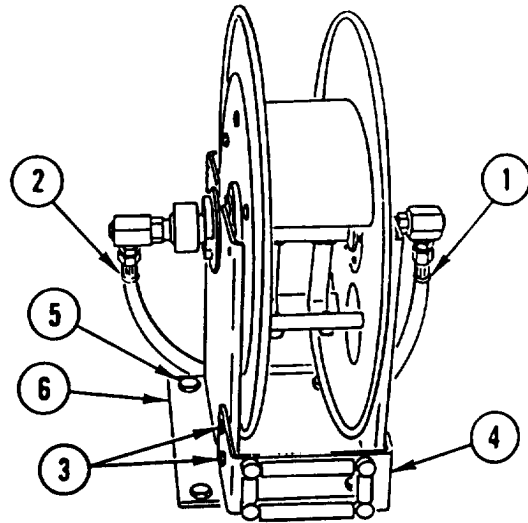

DISASSEMBLY

1. REMOVE two swivel JOINTS (1 and 2)

CAUTION

When using puller, take care not to damage threads.

2. REMOVE socket head SCREW (3) and, USING suitable PULLER, REMOVE SPRING (4).

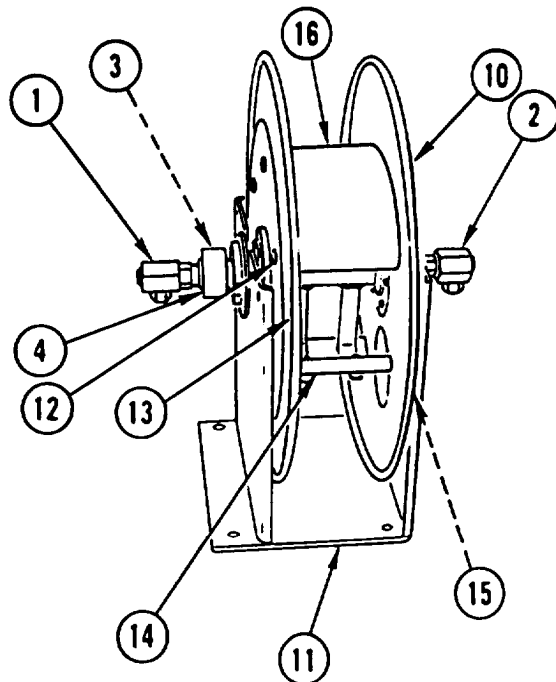

HOSE REEL ASSEMBLY REPLACEMENT AND REPAIR (CONT)

3. REMOVE KEY (5).
4. FROM EACH SIDE, REMOVE two lock nuts (6), outer bearing HOUSING (7), bearing (8), and inner bearing HOUSING (9). DISCARD lock NUTS.
5. REMOVE hose REEL (10) from frame (11).
6. REMOVE six jam nuts (12), disc (13), six spacers (14), six bolts (15), and DRUM (16).

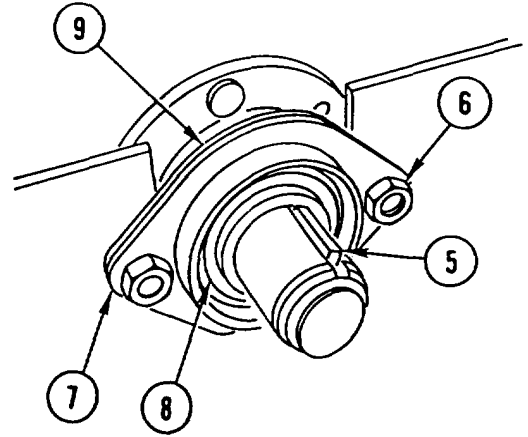

7. REMOVE spring (17), two cotter pins (18), and SHAFT (19) from frame (11). DISCARD cotter PINS.
8. REMOVE pin (20) and PAWL (21) from shaft (19).
9. REMOVE retaining ring (22) and BEARING (23) from frame (11).
10. USING suitable PRESS, REMOVE BEARING (24) from bearing (23).

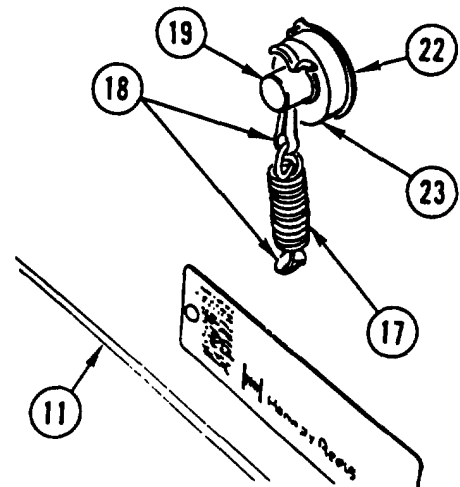

INSPECTION

Inspect bearings (TM 9-21 4).

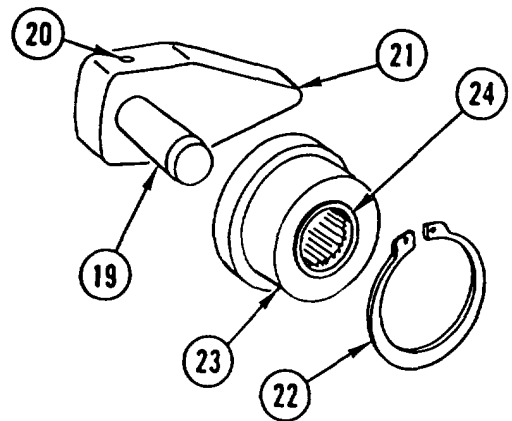

HOSE REEL ASSEMBLY REPLACEMENT AND REPAIR (CONT)

ASSEMBLY

1. USING suitable PRESS, INSTALL BEARING (1) in bearing (2).
2. INSTALL BEARING (2) and retaining ring (3) in frame (4).
3. INSTALL PAWL (5) and pin (6) on shaft (7).

NOTE

When installing cotter pin in shaft, be sure head of cotter pin is down.

INSTALL SHAFT (7), two new cotter pins (8), and spring (9) on frame (4).

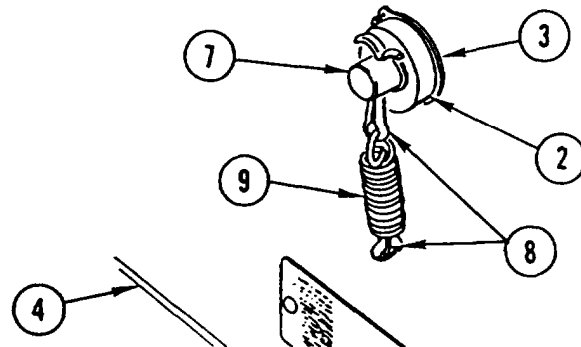
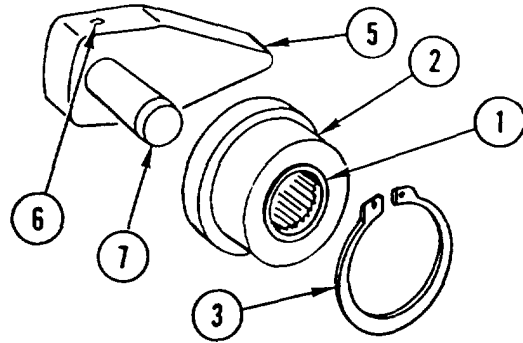

5. INSTALL six bolts (10), six spacers (11), DRUM (12), disc (13), and six jam nuts (14).
6. INSTALL hose REEL (15) on frame (4).

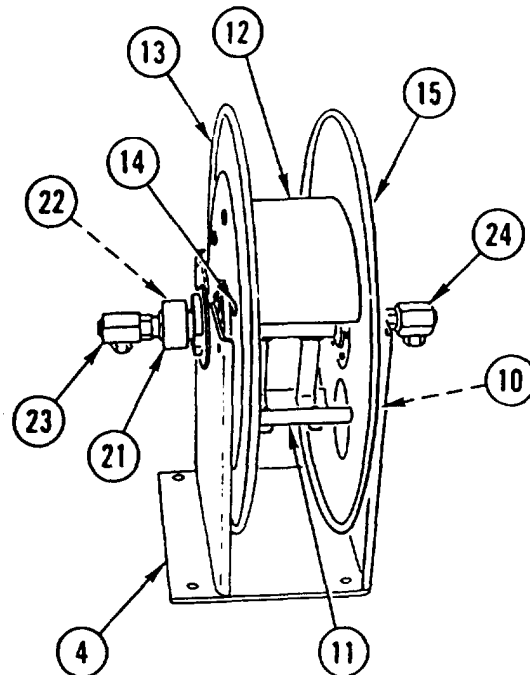

HOSE REEL ASSEMBLY REPLACEMENT AND REPAIR (CONT)

7. ON EACH SIDE, INSTALL inner bearing HOUSING (16), bearing (17), outer bearing HOUSING (18), and two new lock nuts (19).
8. INSTALL KEY (20).
9. USING suitable PRESS, INSTALL SPRING (21).
10. INSTALL socket head SCREW (22).
11. INSTALL two swivel JOINTS (23 and 24).

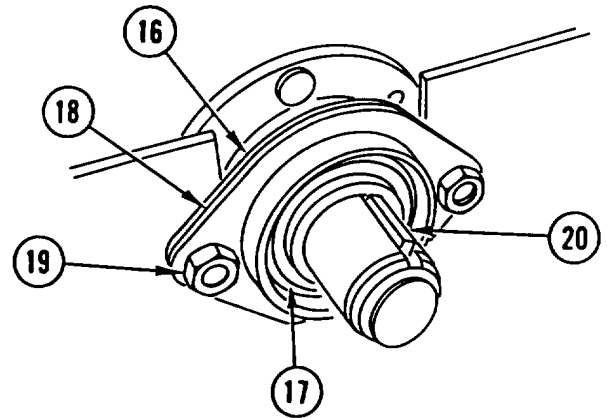
INSTALLATION

1. INSTALL FRAME (1) and four screws (2).
2. INSTALL BRACKET (3) and two bolts (4).
3. REMOVE PLUGS or CAPS. CONNECT two HOSES (5 and 6).

NOTE

Follow-on Maintenance:
 Install hose reel motor spring
 (page 4-464).
 Install hydraulic tool hoses (page
 4-471).

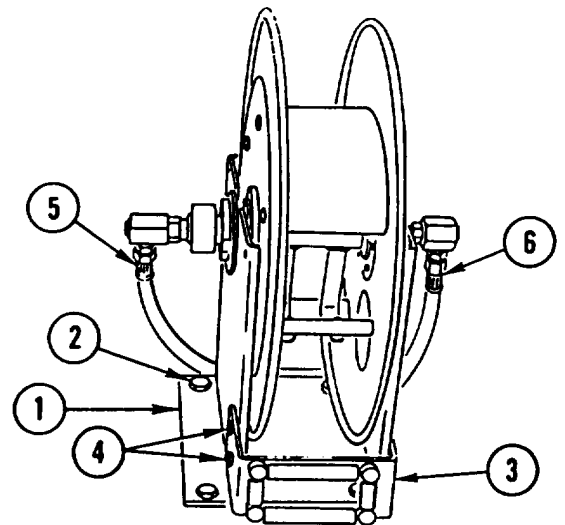

HOSE REEL MOTOR SPRING REPLACEMENT

This task covers: a. Removal b. Installation c. Adjustment

INITIAL SETUP

Tools and Special Equipment:

Tool Kit, SC 5180-90-CL-N26

Materials/Parts:

Caps and Plugs Appendix C, Item 7
 Rags Appendix C, Item 32

Personnel Required: (2)

Equipment Condition:

Reference	Condition Description
Page 2-23	Hydraulic Pressure Relieved

General Safety Instructions:

WARNING

- High pressure hydraulics [oil under 2450 psi (16,893 kPa)] operate this equipment. Never disconnect any hydraulic line or fitting without first dropping pressure to zero. A high pressure oil stream can pierce body and cause severe injury to personnel.
- Fuel and oil are slippery and can cause falls. To avoid injury, wipe up spilled fuel or oil with rags.

REMOVAL

CAUTION

Cap or plug all ports and ends of hoses and tubes to prevent contamination of hydraulic oil. Failure to do so may result in damage to equipment.

1. DISCONNECT hydraulic LINE (1). INSTALL CAPS or PLUGS.
2. REMOVE swivel JOINT (2), washer (3), and dust COVER (4).

WARNING

Spring is under tension. Wear safety goggles. Release tension slowly to avoid personal injury.

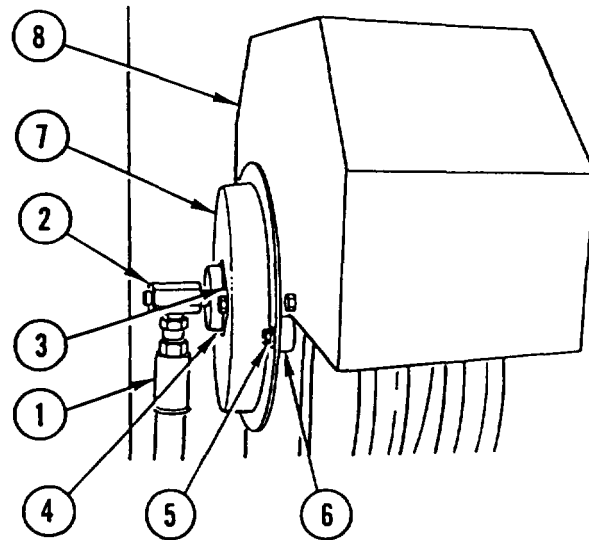

HOSE REEL MOTOR SPRING REPLACEMENT (CONT)

- REMOVE two bolts (5), two spacers (6), and motor SPRING (7) from hose reel assembly (8).

INSTALLATION
NOTE

Make sure hoses are completely wound onto hose reel.

- INSTALL motor SPRING (7) on hose reel assembly (8) and ROTATE motor SPRING (7) TWO COMPLETE TURNS to the RIGHT, preloading spring.
- INSTALL two SPACERS (6) and two bolts (5).
- INSTALL dust COVER (4), washer (3), and swivel JOINT (2).
- REMOVE CAPS or PLUGS. CONNECT hydraulic LINE (1).

ADJUSTMENT

- Pull hose (1) assembly completely out.
- Mark hose reel (2) just below cover (3).

CAUTION

Number of hose reel turns plus preload turns on motor spring must not exceed 13 revolutions on motor spring or damage to motor spring may occur.

- Allow hose (1) to slowly rewind, counting the number of revolutions of hose reel (2) until hose is completely rewound.
- If hoses do not fully retract, repeat Installation steps 1 and 2, increasing preload on motor spring by 1/2 turn until hoses fully retract.

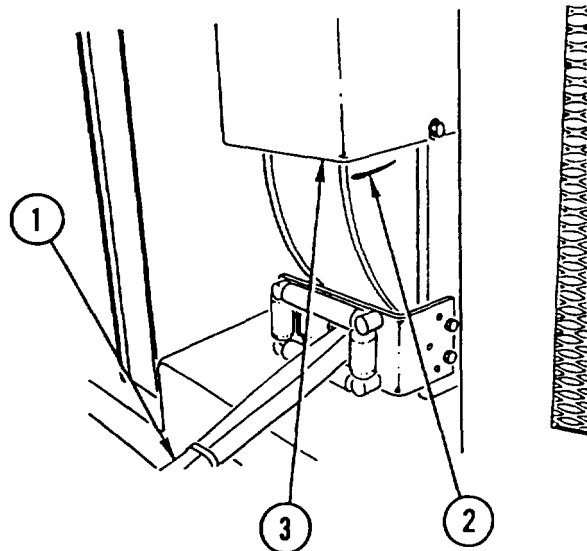

HYDRAULIC ACCESSORY BOX REPLACEMENT AND REPAIR

This task covers: a. Removal b. Disassembly c. Assembly d. Installation

INITIAL SETUP

Applicable Configuration:

SEE

Tools and Special Equipment:

Tool Kit, SC 5180-90-CL-N26

Materials/Parts:

Nut, Lock (12)

Rivet (22)

References:

TM 5-2420-224-10

Equipment Condition:

Reference

TM 5-2420-224-10

Equipment Description

Hydraulic Tools Removed

General Safety instructions:

WARNING

Hydraulic accessory box weighs 94 pounds (43 kilograms). To avoid personal injury, use a hoist or suitable lifting device when Lifting hydraulic accessory box.

REMOVAL

1. REMOVE four nuts (1), four SCREWS (2), and four washers (3).
2. USING suitable HOIST, REMOVE hydraulic accessory BOX (4).

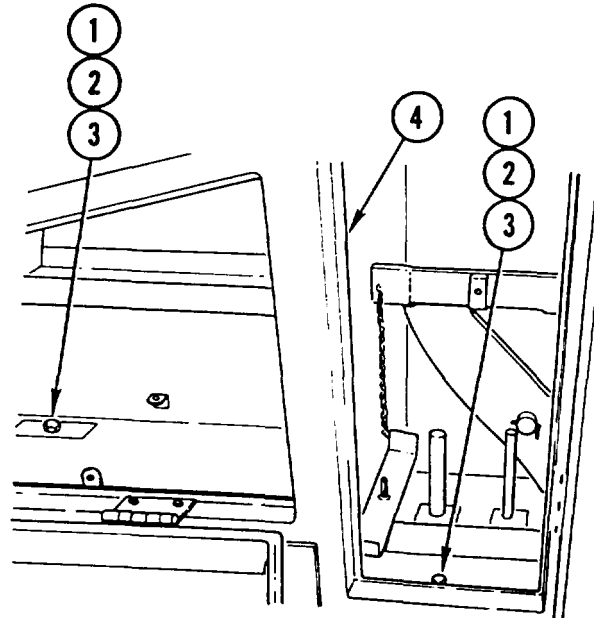

DISASSEMBLY

1. REMOVE four lock nuts (1), four washers (2), four screws (3), and DOOR (4). DISCARD lock NUTS.
2. REMOVE MOLDING (5).
3. REMOVE three rivets (6) and HASP (7). DISCARD RIVETS.
4. REMOVE four lock nuts (8), four washers (9), four screws (10), and DOOR (11). DISCARD lock NUTS.
5. REMOVE MOLDING (12).
6. REMOVE three rivets (13) and HASP (14). DISCARD RIVETS.

HYDRAULIC ACCESSORY BOX REPLACEMENT AND REPAIR (CONT)

7. REMOVE four rivets (15) and STAPLE (16). DISCARD RIVETS.
8. REMOVE 12 rivets (17) and 4 BRACKETS (18). DISCARD RIVETS.
9. REMOVE four lock nuts (19), four screws (20), and TRAY (21). DISCARD lock NUTS.

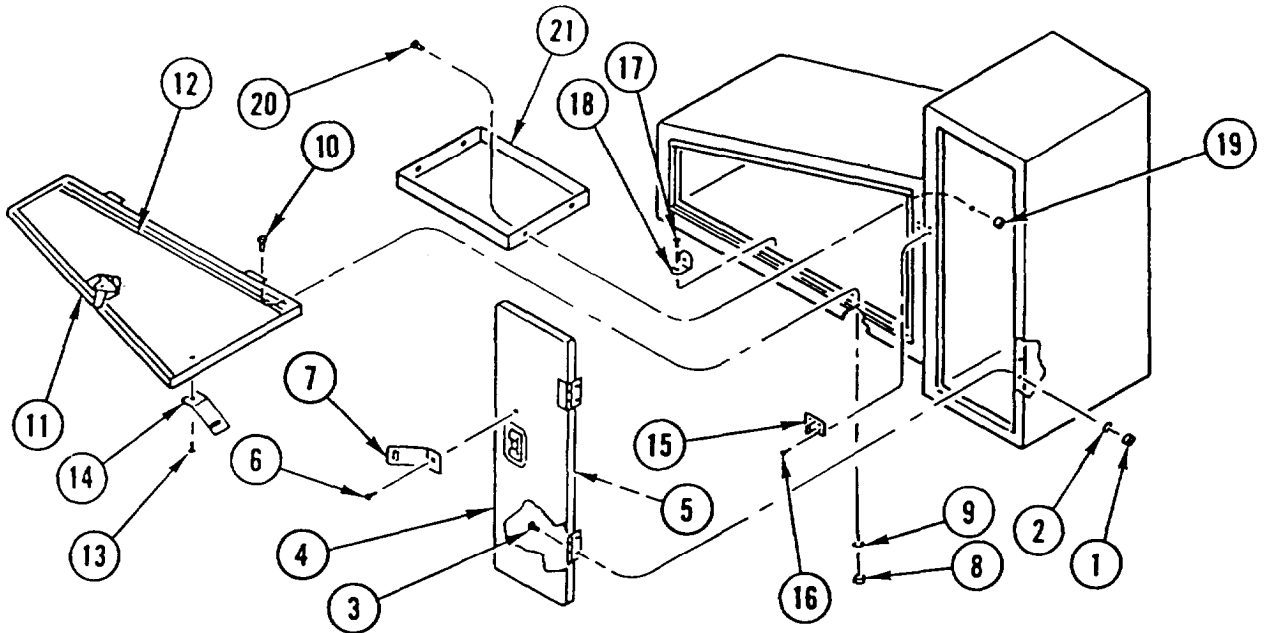
ASSEMBLY

1. INSTALL TRAY (21), four screws (20), and four new lock nuts (19).
2. INSTALL 4 BRACKETS (18) and 12 new rivets (17).
3. INSTALL STAPLE (16) and four new rivets (15).
4. INSTALL HASP (14) and three new rivets (13).
5. INSTALL MOLDING (12).
6. INSTALL DOOR (11), four screws (10), four washers (9), and four new lock nuts (8).
7. INSTALL HASP (7) and three new rivets (6).
8. INSTALL MOLDING (5).
9. INSTALL DOOR (4), four screws (3), four washers (2), and four new lock nuts (1).

INSTALLATION

1. USING suitable HOIST, INSTALL hydraulic accessory BOX (4).
2. INSTALL four SCREWS (2), four washers (3), and four nuts (1).

NOTE

Follow-on Maintenance:
Install hydraulic tools (TM 5-2420-224-10).

HYDRAULIC ACCESSORY BOX REPLACEMENT AND REPAIR

This task covers: a. Removal b. Disassembly c. Assembly d. Installation

INITIAL SETUP

Applicable Configuration:

HMMH

Tools and Special Equipment:

Tool Kit, SC 5180-90-CL-N26

Materials/Parts:

Nut, Lock (6)

General Safety Instructions:

WARNING

Hydraulic accessory box weighs 110 pounds (50 kilograms). To avoid personal injury, use a hoist or suitable lifting device when lifting hydraulic accessory box.

REMOVAL

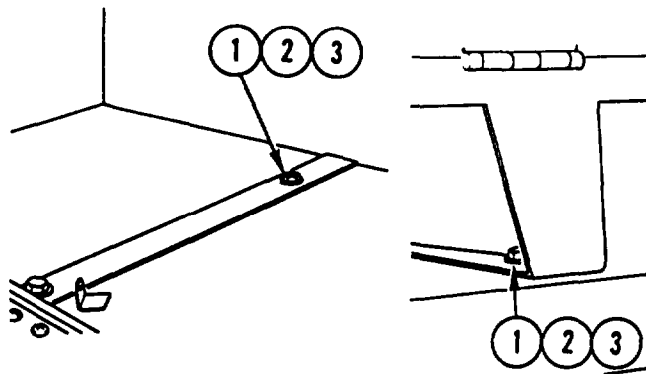

1. REMOVE four nuts (1), four CAPSCREWS (2), and four washers (3).

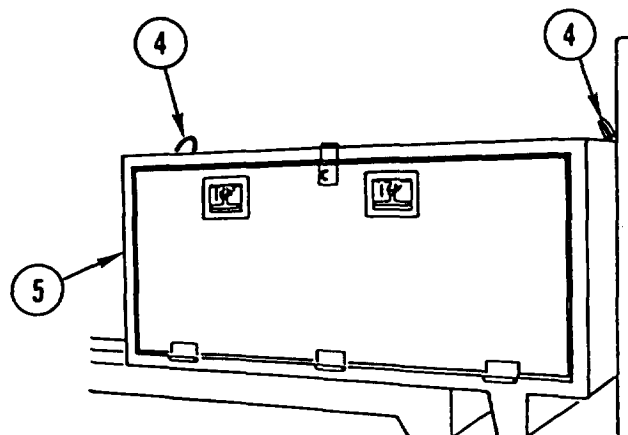

2. USING suitable HOIST attached to lift eyes (4), REMOVE hydraulic accessory BOX (5).

HYDRAULIC ACCESSORY BOX REPLACEMENT AND REPAIR (CONT)

DISASSEMBLY

1. REMOVE TIEDOWN (1).
2. REMOVE six lock nuts (2), six washers (3), six capscrews (4), and hydraulic accessory box LID (5). DISCARD lock NUTS.
3. REMOVE MOLDING (6).

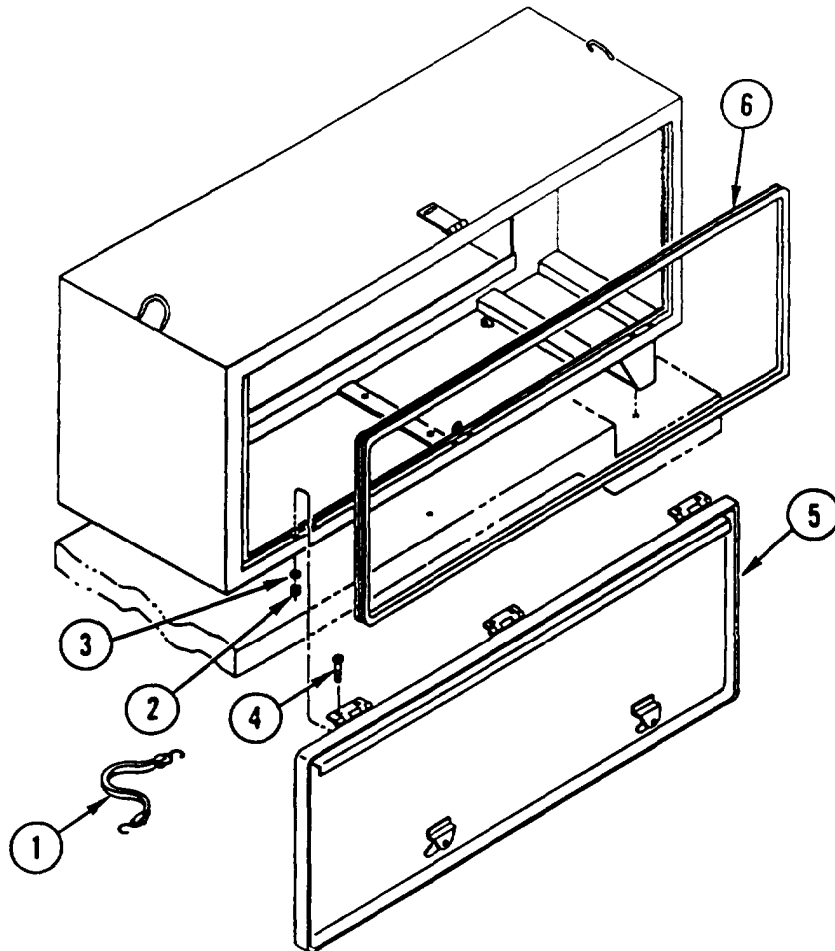
**ASSEMBLY**

1. INSTALL MOLDING (6).
2. INSTALL hydraulic accessory box LID (5), six capscrews (4), six washers (3), and six new lock nuts (2).
3. INSTALL TIEDOWN (1).

HYDRAULIC ACCESSORY BOX REPLACEMENT AND REPAIR (CONT) .

INSTALLATION

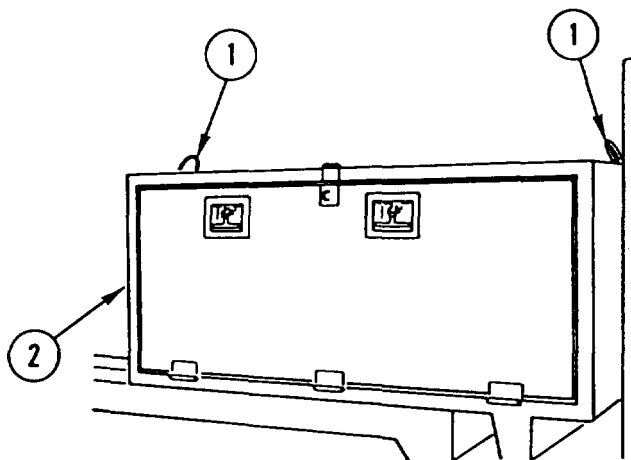

1. USING suitable HOIST attached to lift eyes (1), INSTALL hydraulic accessory BOX (2).

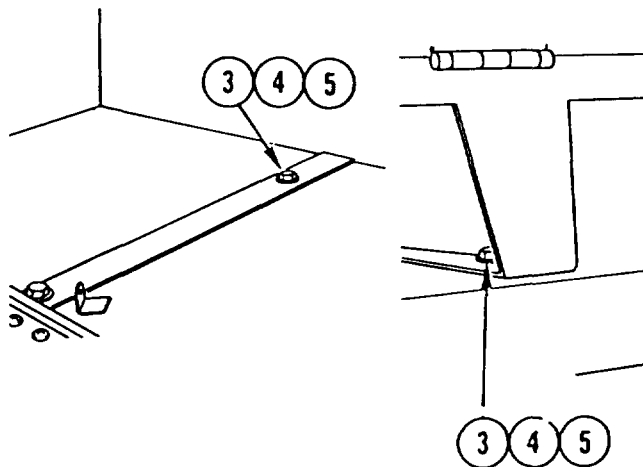

2. INSTALL four CAPSCREWS (3), four washers (4), and four nuts (5).

HYDRAULIC TOOL HOSES REPLACEMENT

This task covers: a. Removal b. Installation

INITIAL SETUP

Tools and Special Equipment:

Shop Equipment, SC 4910-95 -CL-A74
 Tool Kit, SC 5180-90-CL-N26

Materials/Parts:

Strap

Nut, Lock (3)

Packing

Packing

Caps and Plugs Appendix C, Item 7

Rags Appendix C, Item 32

Equipment Condition:

Reference	Condition Description
Page 2-23	Hydraulic Pressure Relieved

General Safety Instructions:

WARNING

- High pressure hydraulics [oil under 2450 psi (16,893 kPa)] operate this equipment. Never disconnect any hydraulic line or fitting without first dropping pressure to zero. A high pressure oil stream can pierce body and cause severe injury to personnel.
- Fuel and oil are slippery and can cause falls. To avoid injury, wipe up spilled fuel or oil with rags.

REMOVAL

NOTE

Make sure hose reel is latched to prevent motor spring from unwinding.

1. REMOVE four bolts (1) and COVER (2).

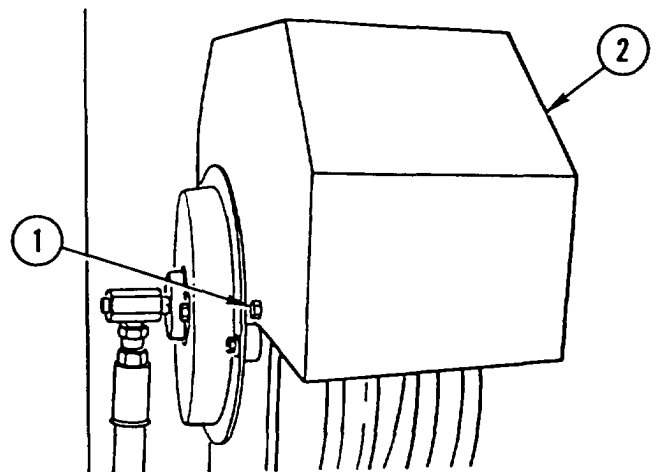

HYDRAULIC TOOL HOSES REPLACEMENT (CONT)

CAUTION

Cap or plug all ports and ends of hoses and tubes to prevent contamination of hydraulic oil. Failure to do so may result in damage to equipment.

NOTE

Tag lines prior to removal to aid in installation.

2. REMOVE two hydraulic tool HOSES (3 and 4) from hose reel assembly (5). INSTALL CAPS or PLUGS on hub body fittings (6 and 7).
3. DRAIN hydraulic OIL from two hydraulic tool hoses (3 and 4) into suitable container. INSTALL CAPS or PLUGS.
4. REMOVE and DISCARD STRAPS (8).
5. REMOVE three lock nuts (9), six washers (10), three screws (11), and CLAMP (12). DISCARD lock NUTS.
6. REMOVE two COUPLINGS (13 and 14) and two packings (15 and 16). DISCARD PACKINGS.

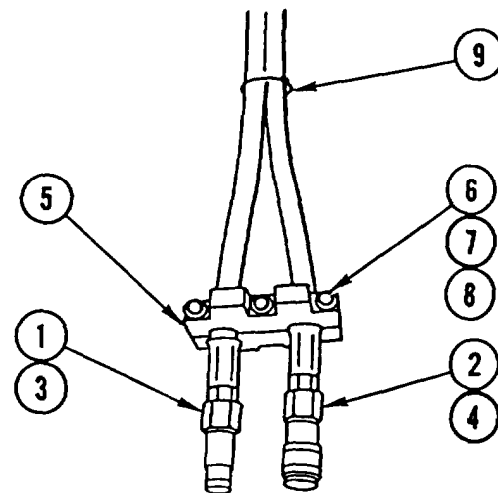
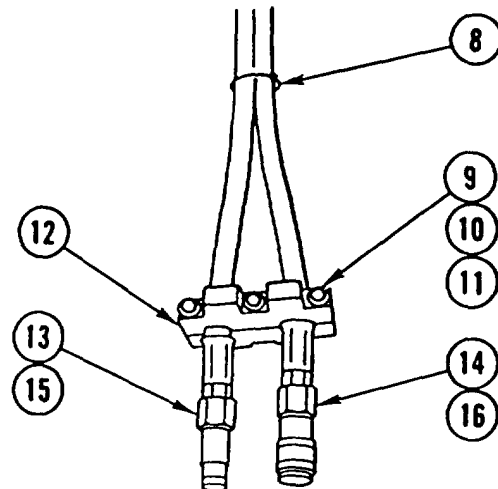
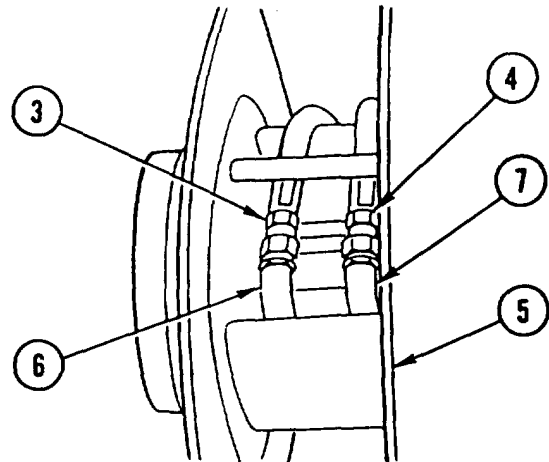

INSTALLATION

1. INSTALL two new packings (1 and 2) and two COUPLINGS (3 and 4).
2. INSTALL CLAMP (5), three screws (6), six washers (7), and three new lock nuts (8).
3. INSTALL new STRAPS (9).

HYDRAULIC TOOL HOSES REPLACEMENT (CONT)

NOTE

If both hydraulic tool hoses are being replaced, install hose with male coupling on left fitting.

4. REMOVE CAPS or PLUGS from hub body fittings (10 and 11). REMOVE CAPS or PLUGS from two hydraulic tool hoses (12 and 13). INSTALL two hydraulic tool HOSES (12 and 13) on hose reel assembly (14).

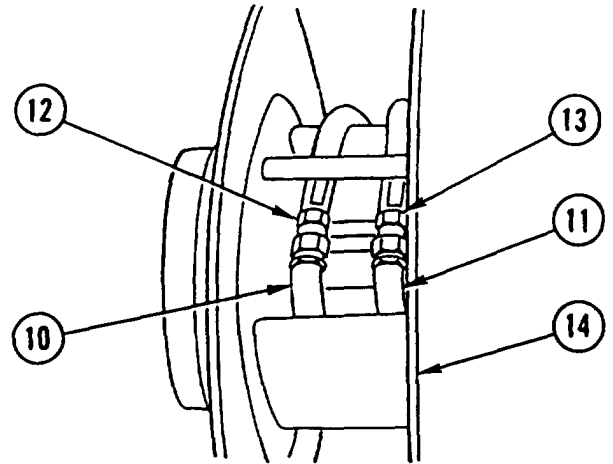

5. INSTALL COVER (15) and four bolts (16).

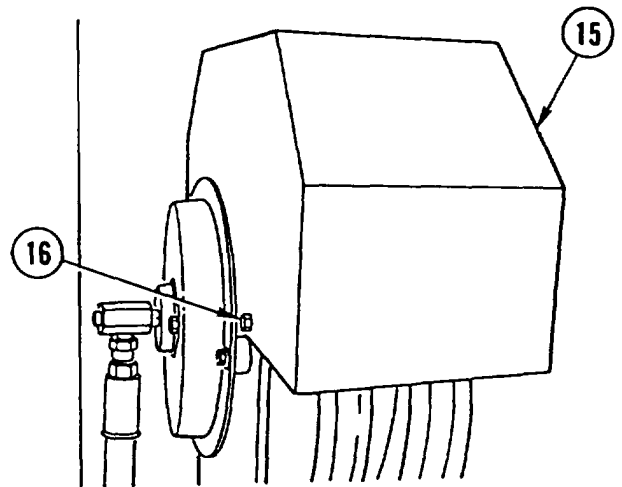

Section XV. BODY AND CHASSIS ACCESSORY ITEMS MAINTENANCE

OVERVIEW

This section illustrates and describes procedures for maintenance of the body and chassis accessory items and related parts. A list of tasks contained in this section is shown below.

	Page
Interior Rear View Mirror Replacement	4-475
Exterior Rear View Mirror Replacement	4-476
Windshield Wiper/Washer Motor Replacement	4-477
Windshield Wiper/Washer Motor Linkage Replacement	4-479
Windshield Wiper Replacement	4-482
Windshield Washer Reservoir Replacement	4-483
Windshield Washer Pump Replacement	4-484
Defroster and Air Tubes Replacement	4-486
Heater Hoses and Clamps Replacement	4-488
Cab Heater Replacement	4-490
Data Plates Replacement	4-492

INTERIOR REAR VIEW MIRROR REPLACEMENT

This task covers: a. Removal b. Installation

INITIAL SETUP

Tools and Special Equipment:

Tool Kit, SC 5180-90-CL-N26

REMOVAL

1. GRASP rear view MIRROR (1) and PULL DOWN to remove from base (2).
2. REMOVE three screws (3) and BASE (2).

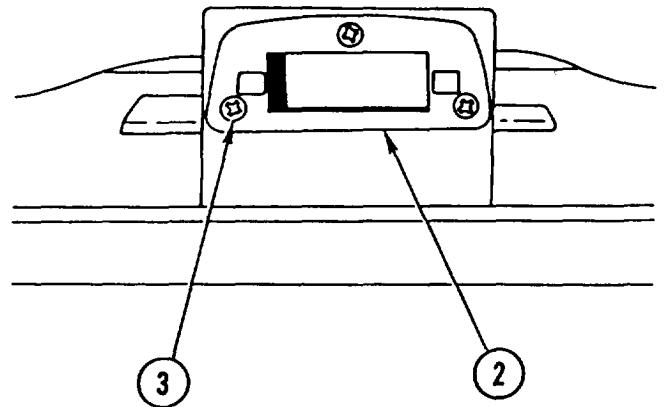
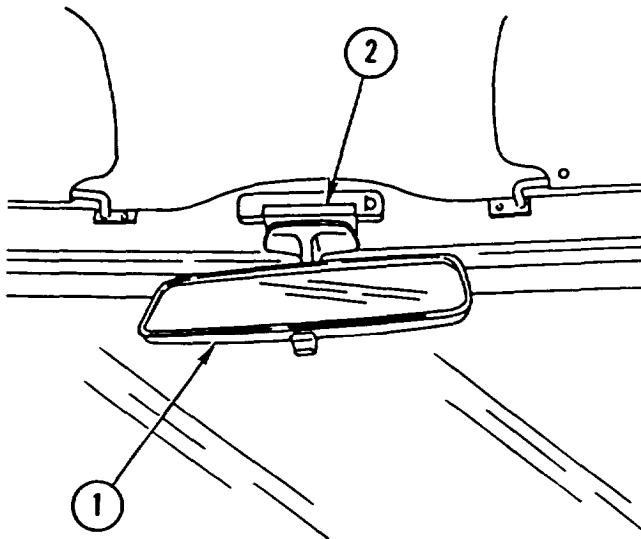

INSTALLATION

1. INSTALL BASE (2) and three screws (3).
2. INSTALL rear view MIRROR (1) in base (2).

EXTERIOR REAR VIEW MIRROR REPLACEMENT

This task covers: a. Removal b. Installation

INITIAL SETUP

Tools and Special Equipment:

Tool Kit, SC 5180-90-CL-N26

Materials/Parts:

Washer, Lock

Nut, Lock (2)

REMOVAL

NOTE

Procedure is the same for both rear view mirrors.

1. REMOVE nut (1), washer (2), lock washer (3), screw (4), rear view MIRROR (5), and clamp (6). DISCARD lock WASHER.
2. REMOVE two lock nuts (7), six washers (8), two bolts (9), and BRACKET (10). DISCARD lock NUTS.
3. REMOVE three screws (11), three washers (12), and mounting BRACKET (13).

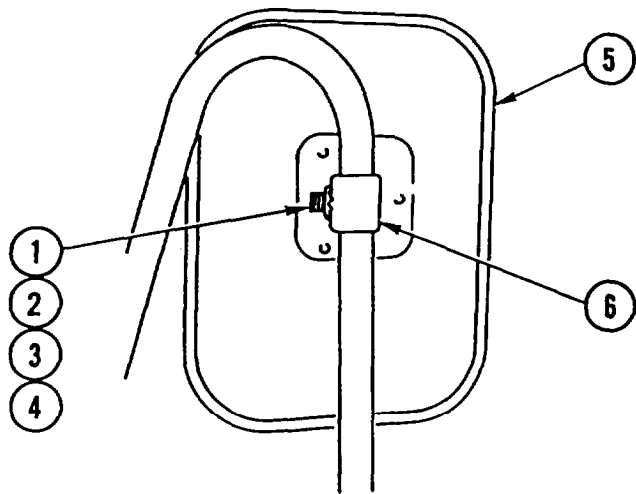

INSTALLATION

NOTE

Procedure is the same for both rear view mirrors.

1. INSTALL mounting BRACKET (13), three screws (11), and three washers (12).
2. INSTALL BRACKET (10), two bolts (9), six washers (8), and two new lock nuts (7).
3. INSTALL clamp (6), rear view MIRROR (5), screw (4), washer (2), new lock washer (3), and nut (1).

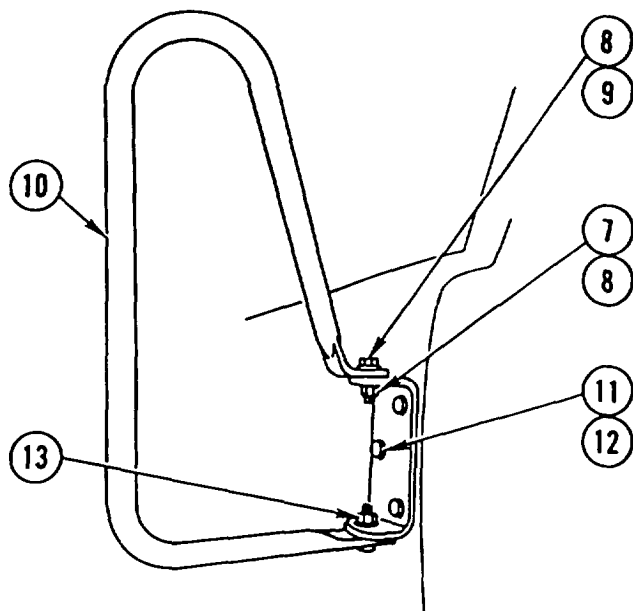

WINDSHIELD WIPER/WASHER MOTOR REPLACEMENT

This task covers: a. Removal b. Installation

INITIAL SETUP

Tools and Special Equipment:

Tool Kit, SC 5180-90-CL-N26

Materials/Parts:

Washer, Lock

Equipment Condition:

Reference	Condition Description
Page 4-487	Defroster and Air Tubes Removed
Page 4-38	Air Cleaner Ducts Removed
Page 4-794 or 4-546	Front Loader (SEE) or Forklift (HMMH) Removed

General Safety Instructions:

W A R N I N G

- SEE/HMMH should not be operated with front loader (SEE) or forklift (HMMH) removed, except in a maintenance facility. When maintenance is required and front loader or forklift is removed, never operate SEE/HMMH at speeds greater than 5 mph. Tractor stability and handling characteristics are greatly affected with either front loader or forklift removed. This could cause loss of control and injury to personnel or damage to vehicle.
- Do not connect or disconnect any electrical connector unless vehicle MASTER disconnect switch is OFF. To do so could result in injury to personnel.

WINDSHIELD WIPER/WASHER MOTOR REPLACEMENT (CONT)

REMOVAL

NOTE

Procedure is the same for both vehicles.

1. DISCONNECT electrical CONNECTOR (1).
2. REMOVE NUT (2) and lock washer (3) and DISCONNECT LEVER (4). DISCARD lock WASHER.
3. REMOVE two nuts (5), two washers (6), and wiper/washer MOTOR (7).

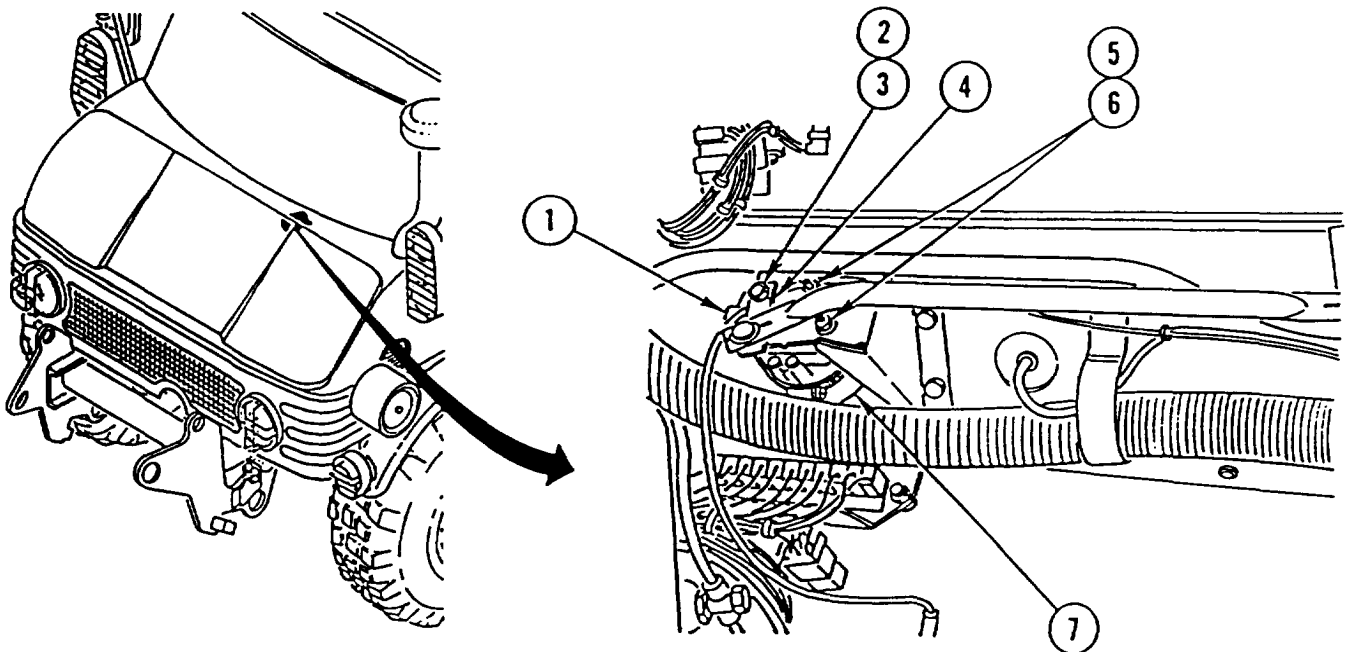

INSTALLATION

NOTE

Procedure is the same for both vehicles.

1. INSTALL wiper/washer MOTOR (7), two washers (6), and two nuts (5).
2. CONNECT LEVER (4) and INSTALL new lock washer (3) and NUT (2).
3. CONNECT electrical CONNECTOR (1).

NOTE

Follow-on Maintenance:

Install defroster and air tubes (page 4-487).

Install air cleaner ducts (page 4-38).

Install front loader (SEE) or forklift (HMMH) (page 4-794 or 4-546)

WINDSHIELD WIPER/WASHER MOTOR LINKAGE REPLACEMENT

This task covers: a. Removal b. Installation

INITIAL SETUP

Tools and Special Equipment:

Shop Equipment, SC 4910-95-CL-A74
 Tool Kit, SC 5180-90-CL-N26

Materials/Parts:

Washer, Spring
 Tension (2)

Kit, Parts

Equipment Condition:

Reference	Condition Description
Page 4-794 or 4-546	Front Loader (SEE) or Forklift (HMMH) Removed
Page 4-486	Defroster and Air Tubes Removed
Page 4-38	Air Cleaner Ducts Removed
Page 4-482	Windshield Wipers Removed
Page 4-477	Windshield Wiper/Washer Motor Removed
Page 4-389	inside Engine Hood Removed

General Safety Instructions:

W A R N I N G

SEE/HMMH should not be operated with front loader (SEE) or forklift (HMMH) removed, except in a maintenance facility. When maintenance is required and front loader or forklift is removed, never operate SEE/HMMH at speeds greater than 5 mph. Tractor stability and handling characteristics are greatly affected with front loader or forklift removed. This could cause loss of control and injury to personnel or damage to vehicle.

WINDSHIELD WIPER/WASHER MOTOR LINKAGE REPLACEMENT (CONT)

REMOVAL

NOTE

Procedure is the same for both vehicles.

1. DISCONNECT connecting LINK (1) from drive member(2).
2. REMOVE connecting LINK (1) from lever (3).
3. DISCONNECT connecting LINK (4) from drive member (2).
4. REMOVE connecting LINK (4) from drive member (5).
5. REMOVE and DISCARD conical SEAL (6), NUT (7), WASHER (8), and WASHER (9) from drive member (2).
6. REMOVE and DISCARD conical SEAL (10), NUT (11), WASHER (12), and WASHER (13) from drive member (5).
7. REMOVE two bolts (14), two spring tension washers (15), and structural frame SECTION (16) from cab. DISCARD spring tension WASHERS.
8. REMOVE and DISCARD two NUTS (17) and two drive MEMBERS (2 and 5) from structural frame section (16).
9. REMOVE nut (18), washer (19), and LEVER (3) from structural frame section (16).

INSTALLATION

NOTE

Procedure is the same for both vehicles.

1. INSTALL LEVER (3), washer (19), and nut (18) on structural frame section (16).
2. INSTALL two new drive MEMBERS (2 and 5) and two new nuts (17) on structural frame section (16).
3. INSTALL structural frame SECTION (16), two new spring tension washers (15), and two bolts (14) in cab.
4. INSTALL new washer (13), new washer (12), new nut (11), and new conical SEAL (10) on drive member (5).
5. INSTALL new washer (9), new washer (8), new nut (7), and new conical SEAL (6) on drive member (2).
6. INSTALL connecting LINK (4) on drive member (5).
7. CONNECT connecting LINK (4) to drive member (2).
8. INSTALL connecting LINK (1) on lever (3).
9. CONNECT connecting LINK (1) to drive member (2).

NOTE

Follow-on Maintenance:

Install front loader (SEE) or forklift (HMMH) (page 4-794 or 4-546).

Install defroster and air tubes (page 4-486).

Install air cleaner ducts (page 4-38).

Install windshield wipers (page 4-482).

Install windshield wiper/washer motor (page 4-477).

Install inside engine hood (page 4-389).

WINDSHIELD WIPER/WASHER MOTOR LINKAGE REPLACEMENT (CONT)

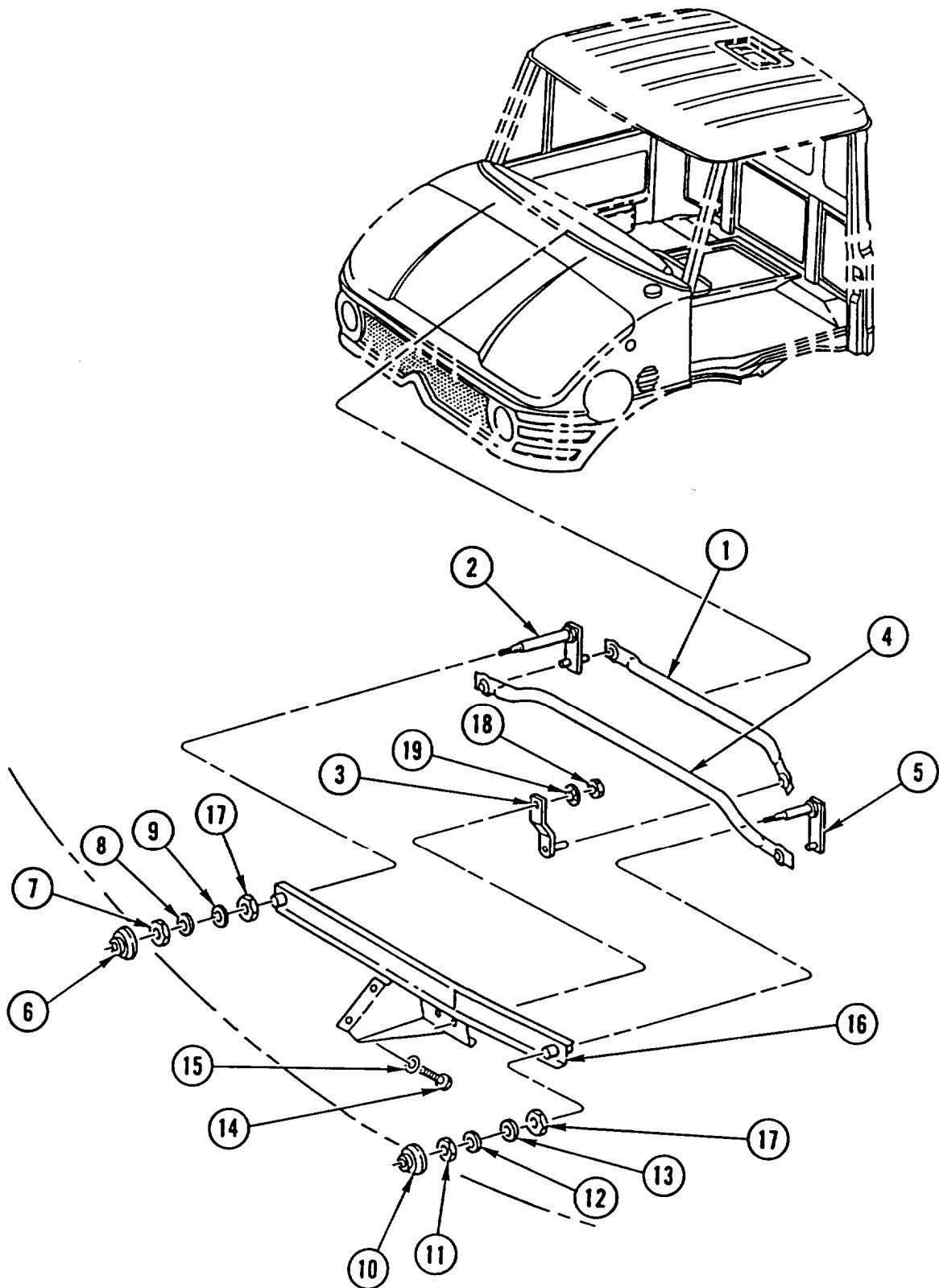

WINDSHIELD WIPER REPLACEMENT

This task covers: a. Removal b. Installation

INITIAL SETUP

Tools and Special Equipment:

Tool Kit, SC 5180-90-CL-N26

Materials/Parts:

Washer, Spring
Tension

REMOVAL

NOTE

Procedure is the same for both windshield wipers.

1. REMOVE dust PLUG (1) from arm (2).
2. REMOVE nut (3), spring tension washer (4), and ARM (2). DISCARD spring tension WASHER.
3. PRESS TAB and REMOVE windshield wiper HOLDER (5).
4. REMOVE windshield wiper BLADE (6) from windshield wiper holder (5).

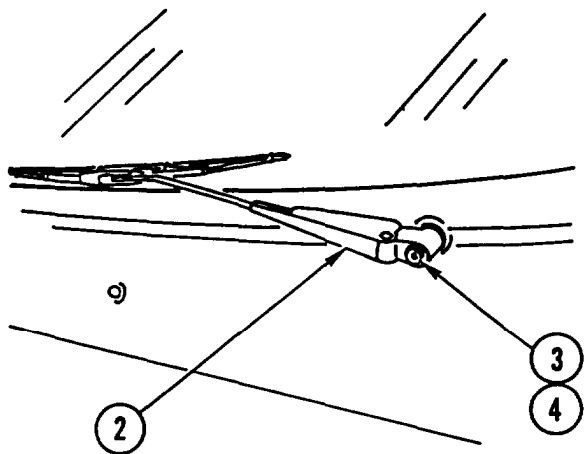
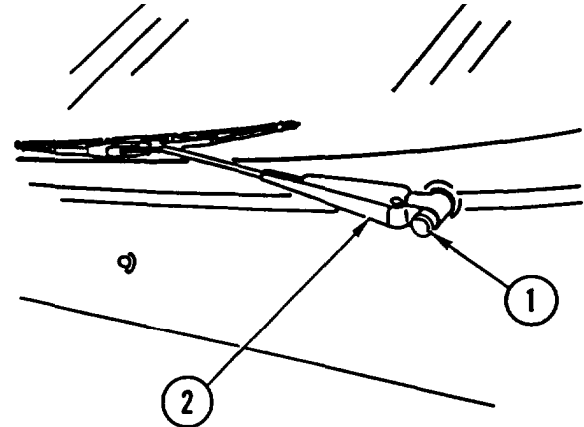

INSTALLATION

NOTE

Procedure is the same for both windshield wipers.

1. INSTALL windshield wiper BLADE (6) on windshield wiper holder (5).
2. INSTALL windshield wiper HOLDER (5) on arm (2).
3. INSTALL ARM (2), new spring tension washer (4), and nut (3).
4. INSTALL dust PLUG (1) on arm (2).

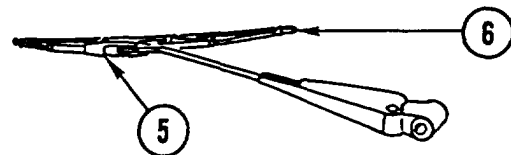

WINDSHIELD WASHER RESERVOIR REPLACEMENT

This task covers: a. Removal b. Installation

INITIAL SETUP

Tools and Special Equipment:

Tool Kit, SC 5180-90-CL-N26

Materials/Parts:

Washer, Spring
Tension

References:

None

Equipment Condition:

Reference

Page 4-388

Condition Description

Outside Engine Hood
Removed

REMOVAL

1. Disconnect HOSE (1) from windshield washer reservoir (2).
2. REMOVE nut (3), washer (4), spring tension washer (5), bolt (6), and windshield washer RESERVOIR (2) from vehicle. DISCARD spring tension WASHER.
3. REMOVE CAP (7).
4. REMOVE HOSE (8) and elbow (9) from cap (7).

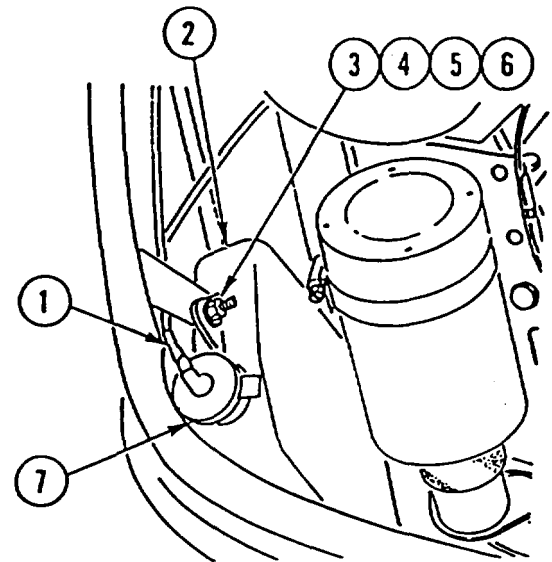

INSTALLATION

1. INSTALL elbow (9) and HOSE (8) on cap (7).
2. INSTALL CAP (7).
3. INSTALL windshield washer RESERVOIR (2), bolt (6), washer (4), new spring tension washer (5), and nut (3) on vehicle.
4. CONNECT HOSE (1) to windshield washer reservoir (2).

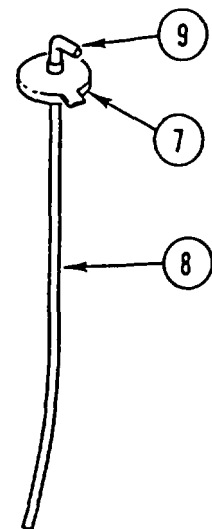

NOTE

Follow-on Maintenance:

Fill windshield washer reservoir
(page 2-14).
Install outside engine hood (page
4-388).

WINDSHIELD WASHER PUMP REPLACEMENT

This task covers: a. Removal b. Installation

INITIAL SETUP

Tools and Special Equipment:

Tool Kit, SC 5180-90-CL-N26

Equipment Condition:

Reference

Page 4-388

Condition Description

Outside Engine Hood
Removed

General Safety Instructions:

WARNING

Do not connect or disconnect any electrical connector unless vehicle MASTER disconnect switch is OFF. To do so could result in injury to personnel.

REMOVAL

1. Disconnect electrical CONNECTOR (1).

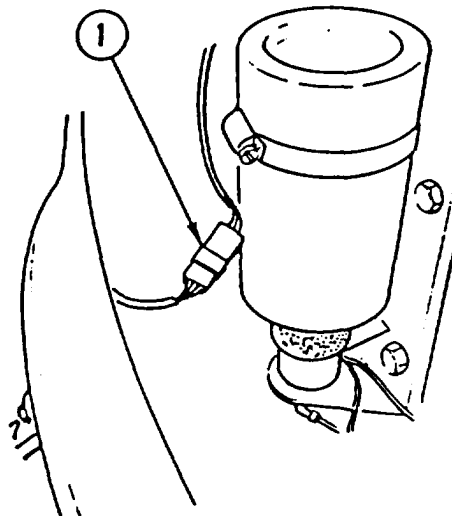

2. Disconnect HOSE (2).

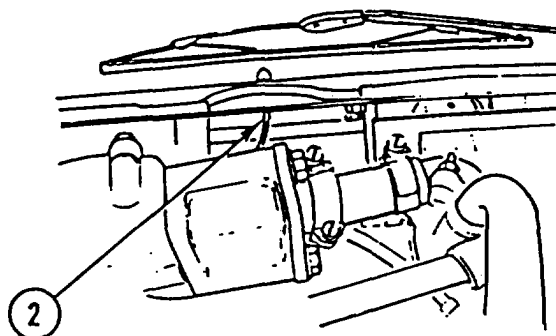

WINDSHIELD WASHER PUMP REPLACEMENT (CONT)

3. REMOVE three nuts (3), three screws (4), and windshield washer PUMP (5).

INSTALLATION

1. INSTALL windshield washer PUMP (5), three screws (4), and three nuts (3).
2. CONNECT HOSE (2).
3. CONNECT electrical CONNECTOR (1).

NOTE

Follow-on Maintenance:
Install outside engine hood (page 4-388).

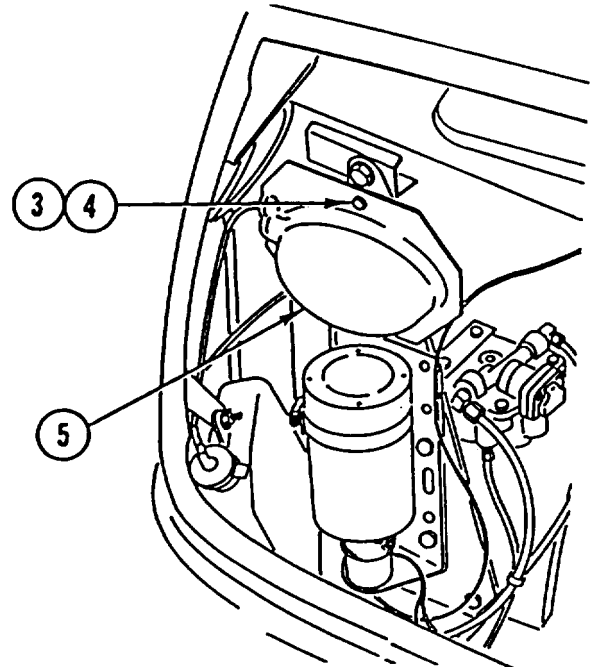

DEFROSTER AND AIR TUBES REPLACEMENT

This task covers: a. Removal b. Installation

INITIAL SETUP

Tools and Special Equipment:

Tool Kit, SC 5180-90-CL-N26

Materials/Parts:

Washer, Spring
Tension (2)

Gasket

Equipment Condition:

Reference

Page 4-38

Condition Description

Air Cleaner Ducts
Removed

REMOVAL

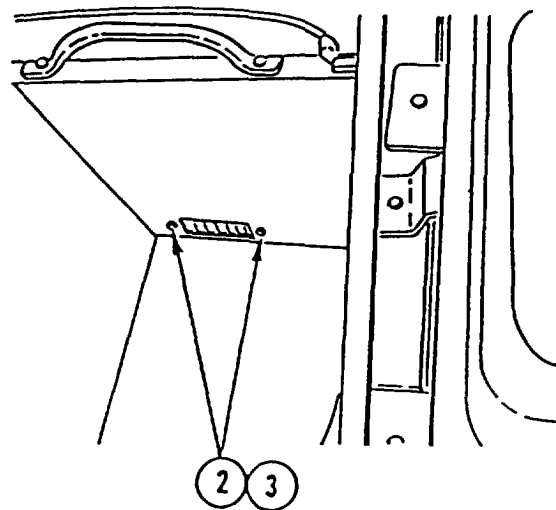
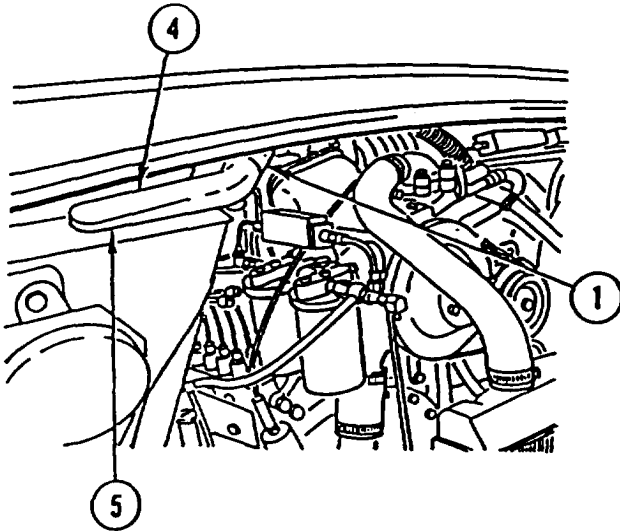

1. REMOVE HOSE (1).
2. REMOVE two nuts (2), two spring tension washers (3), NOZZLE (4), and gasket (5). DISCARD spring tension WASHERS and GASKET.

DEFROSTER AND AIR TUBES REPLACEMENT (CONT)

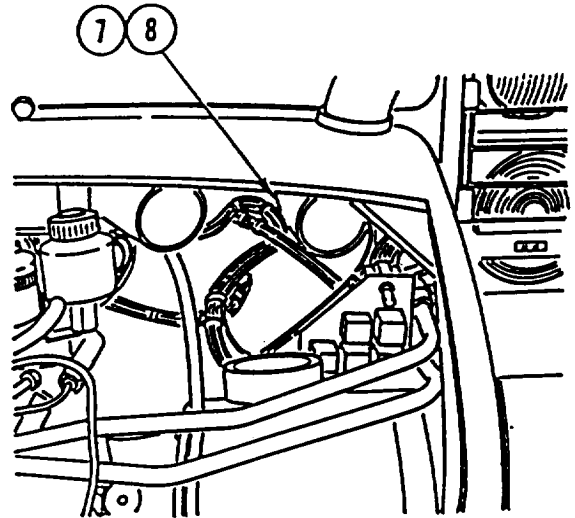
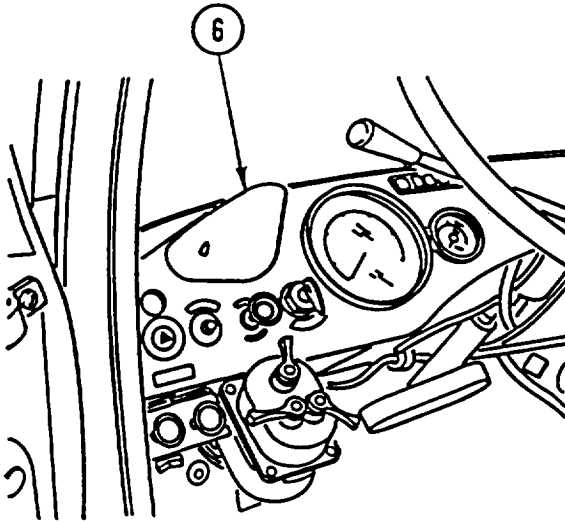

3. REMOVE defroster NOZZLE (6), hose (7), and elbow (8).

INSTALLATION

1. INSTALL elbow (8), hose (7), and defroster NOZZLE (6).
2. INSTALL new gasket (5), NOZZLE (4), two new spring tension washers (3), and two nuts (2).
3. INSTALL HOSE (1).

NOTE

Follow-on Maintenance:
Install air cleaner ducts (page 4-38).

HEATER HOSES AND CLAMPS REPLACEMENT

This task covers: a. Removal b. Installation

INITIAL SETUP

Tools and Special Equipment:

Tool Kit, SC 5180-90-CL-N26

Equipment Condition:

Reference	Condition Description
Page 4-388	Outside Engine Hood Removed
Page 4-87	Cooling System Drained

REMOVAL

NOTE

Tag lines prior to removal to aid in installation.

REMOVE HOSES and CLAMPS using illustration and legend as a guide.

INSTALLATION

INSTALL HOSES and CLAMPS using illustration and legend as a guide.

NOTE

Follow-on Maintenance:

- Fill cooling system (page 4-87).
- Install outside engine hood (page 4-388).

LEGEND

- 1 Screw (4)
- 2 Washer
- 3 Bracket
- 4 Nut (4)
- 5 Clamp (6)
- 6 Clamp (8)
- 7 Hose
- 8 Hose
- 9 Tube
- 10 Tube
- 11 Hose
- 12 Hose

HEATER HOSES AND CLAMPS REPLACEMENT (CONT)

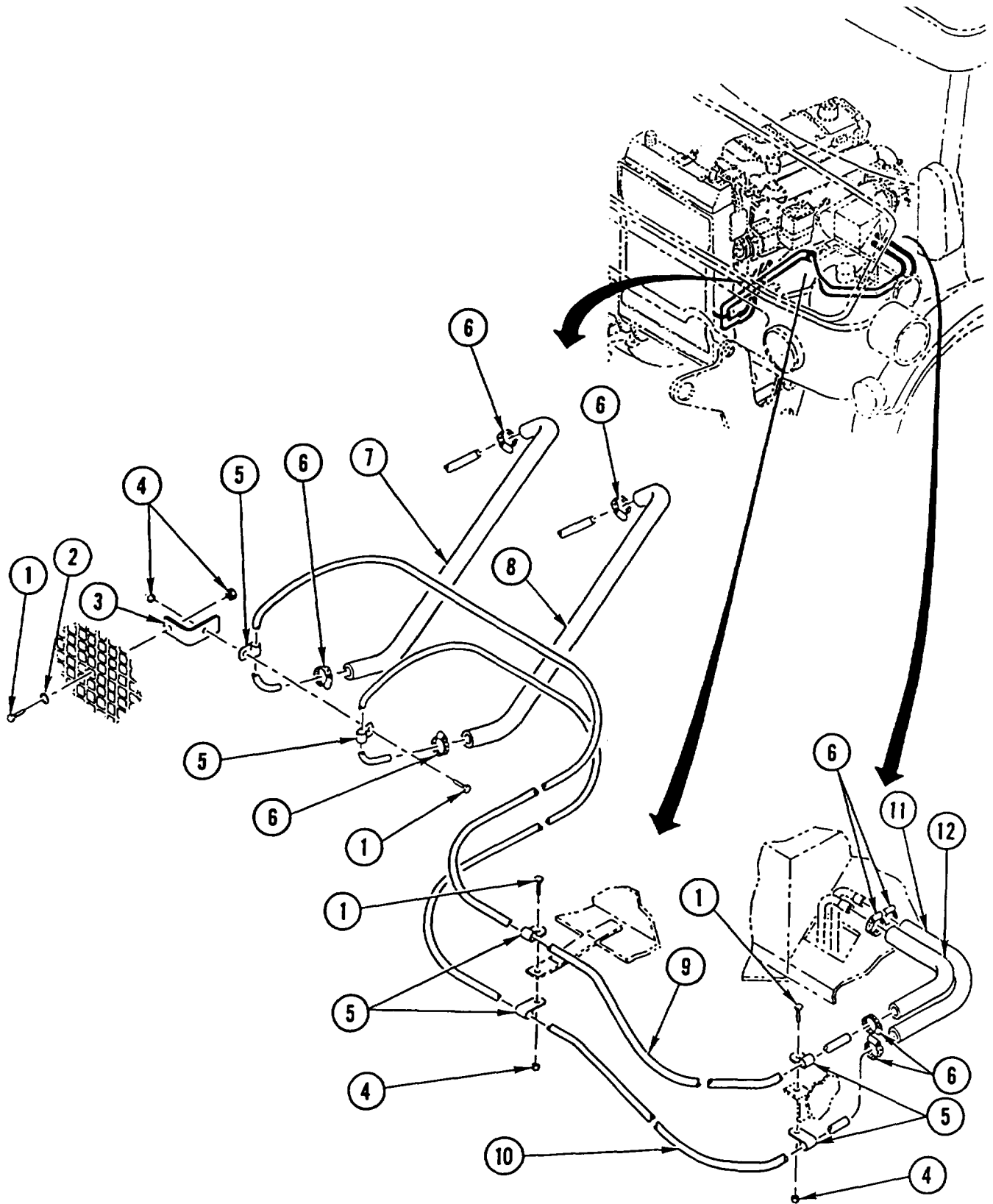

CAB HEATER REPLACEMENT

This task covers: a. Removal b. Installation

INITIAL SETUP

Tools and Special Equipment:

Tool Kit, SC 5180-90-CL-N26

Equipment Condition:

Reference	Condition Description
Page 4-137	Master Light Switch Removed
Page 4-139	Windshieid Heater Control Switch Removed
Page 4-38	Air Cleaner Ducts Removed
Page 4-92	Radiator Drained

General Safety Instructions:

WARNING

Do not connect or disconnect any electrical connector unless vehicle MASTER disconnect switch is OFF. To do so could result in injury to personnel.

REMOVAL

NOTE

Tag lines prior to disconnecting to aid in connecting.

1. LOOSEN two CLAMPS (1) and DISCONNECT two HOSES (2).
2. Disconnect electrical CONNECTOR (3).
3. REMOVE two SCREWS (4) and two washers (5).
4. REMOVE screw (6), washer (7), and HEATER (8).

CAB HEATER REPLACEMENT (CONT)

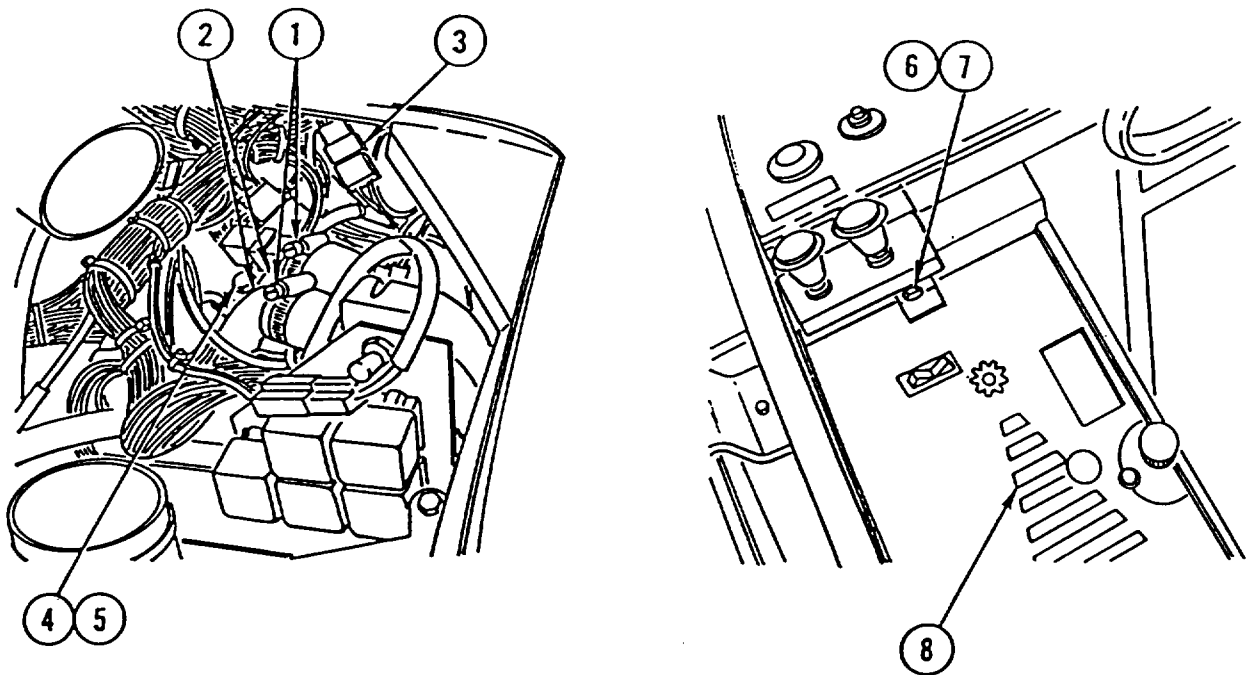

INSTALLATION

1. INSTALL HEATER (8), washer (7), and screw (6).
2. INSTALL two washers (5) and two SCREWS (4).
3. CONNECT electrical CONNECTOR (3).
4. CONNECT two HOSES (2) and TIGHTEN two CLAMPS (1).

NOTE

Follow-on Maintenance:

- Install master light switch (page 4-137).
- Install windshield heater control switch (page 4-139).
- Install air cleaner ducts (page 4-38).
- Fill radiator (page 4-92).

DATA PLATES REPLACEMENT

This task covers: a. Removal b. Installation

INITIAL SETUP

Tools and Special Equipment:

Shop Equipment, SC 4910-95-CL-A74
Tool Kit, SC 5180-90-CL-N26

Materials/Parts:

Screw, Drive (AR)
Rivet (AR)
Washer (AR)

REMOVAL

NOTE

If damaged, discard drive screw(s), rivet(s), or washer(s).

1. REMOVE attaching drive screws and data PLATES using illustrations and legends as a guide.
2. USE putty KNIFE to REMOVE SCREWLESS data PLATES using illustrations and legends as a guide.

INSTALLATION

NOTE

If discarded, install new drive screw(s), rivet(s), or washer(s).

1. ATTACH data PLATES with drive screws using illustrations and legends as a guide.
2. TO ATTACH SCREWLESS data PLATES, FOLLOW INSTRUCTIONS on back of data plate.

LEGEND

- 1 Starter decal
- 2 Identification marker
- 3 Horn and headlights decal
- 4 Identification marker
- 5 Identification marker
- 6 Identification marker
- 7 Identification plate
- 8 Instruction plate
- 9 Differential lock decal
- 10 Identification marker
- 11 Identification marker
- 12 Identification marker
- 13 Identification marker
- 14 Warranty decal
- 15 Identification plate
- 16 Identification plate
- 17 Identification marker
- 18 Identification marker
- 19 Identification marker

DATA PLATES REPLACEMENT (CONT)

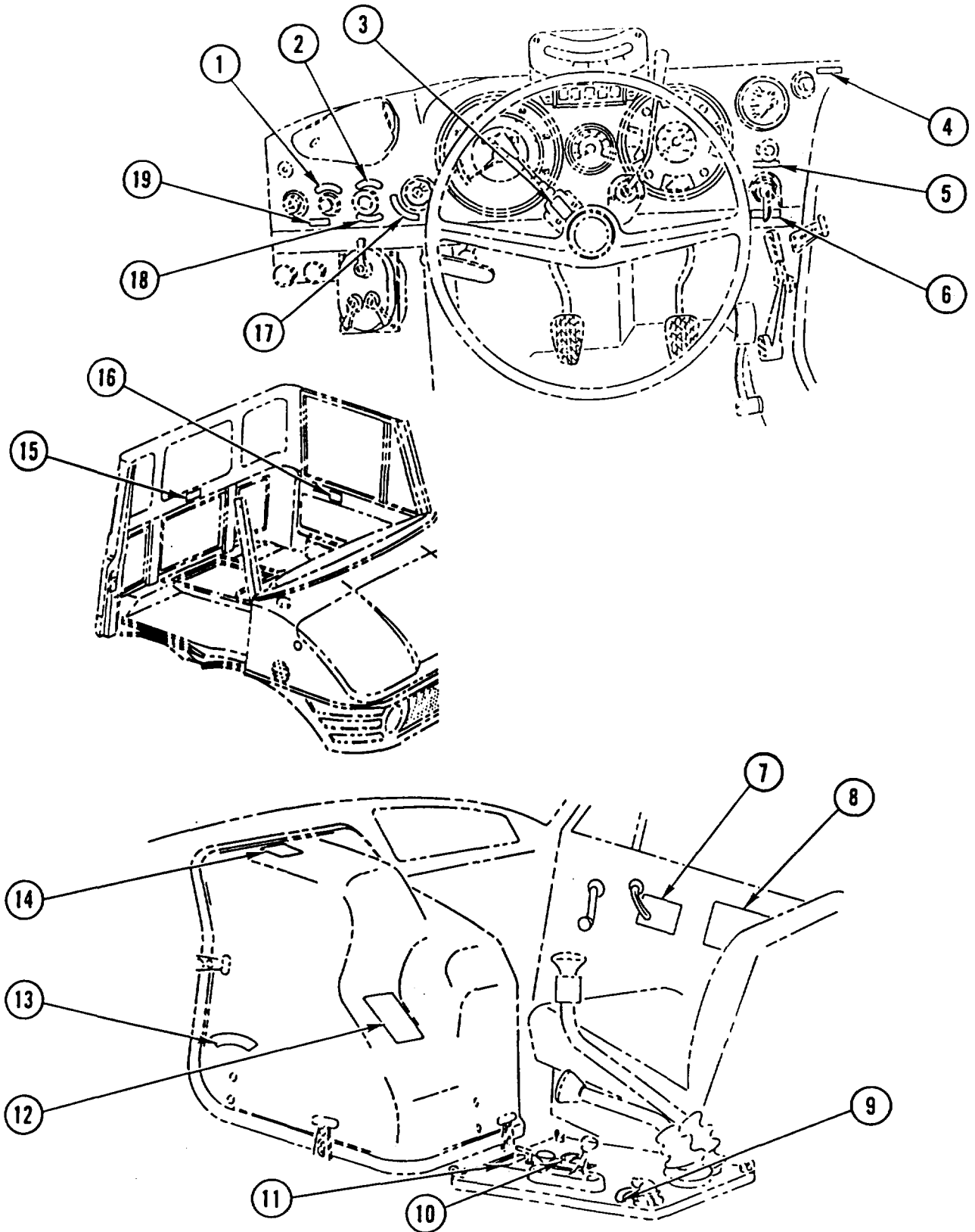

DATA PLATES REPLACEMENT (CONT)

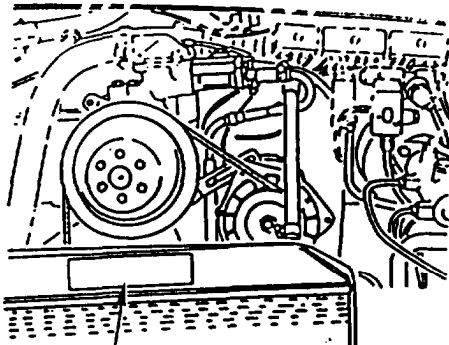

7

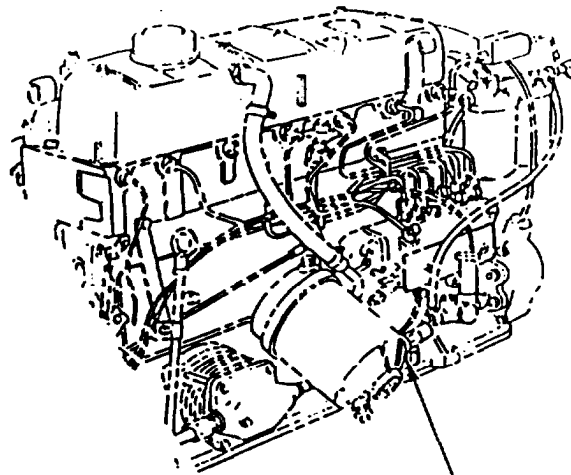

1

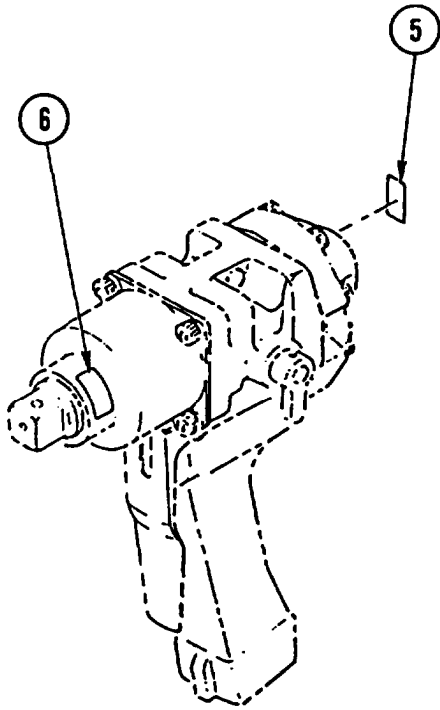

5

6

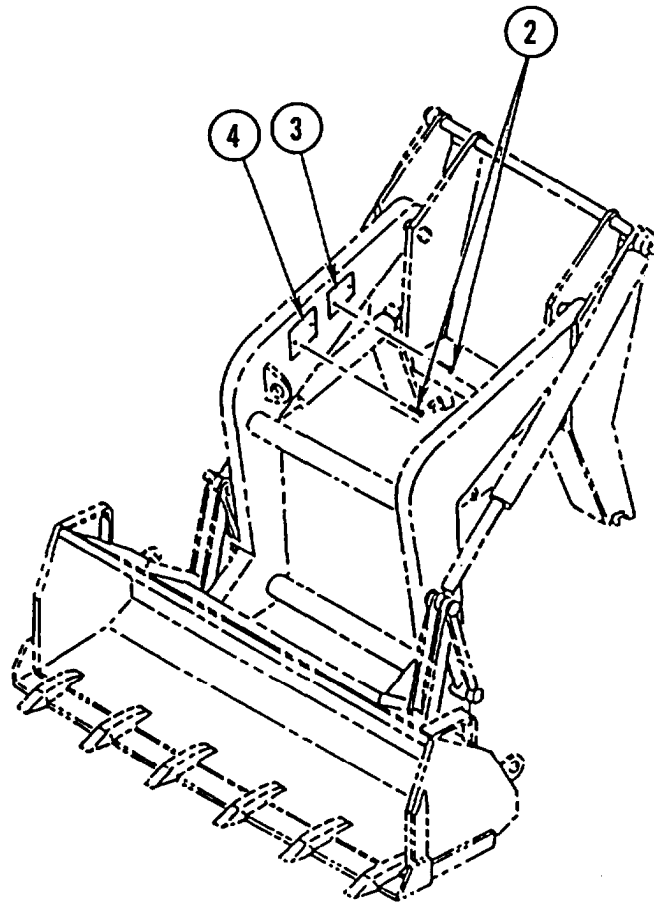

2

4

3

LEGEND

- 1 Identification marker
- 2 Drive screw (4)
- 3 Instruction plate
- 4 Identification plate
- 5 Identification plate
- 6 Identification marker
- 7 Fan warning decal

DATA PLATES REPLACEMENT (CONT)

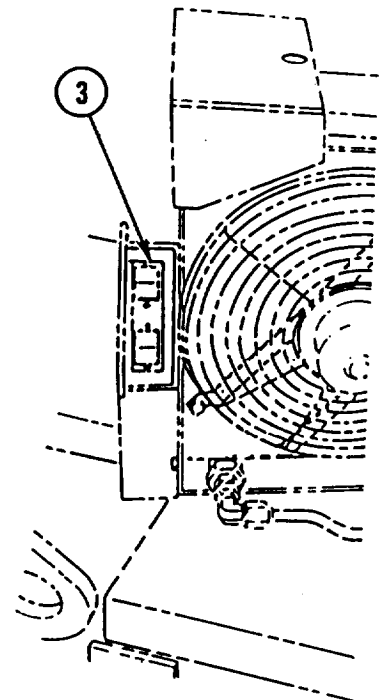
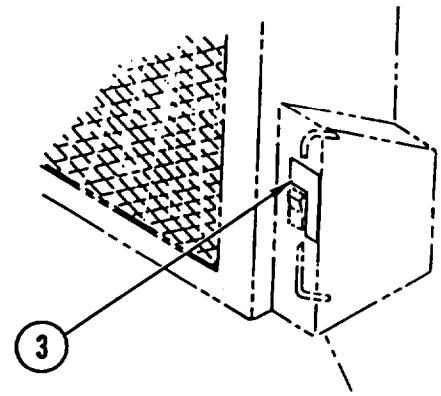
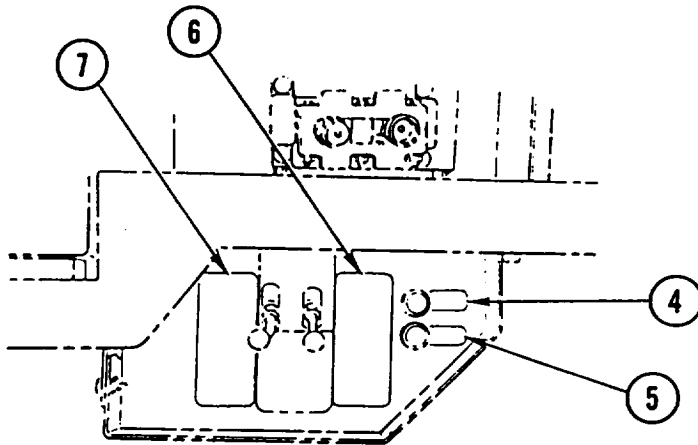
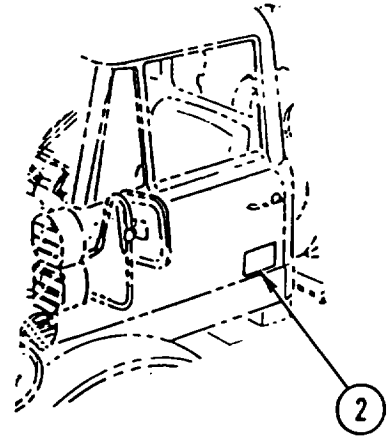
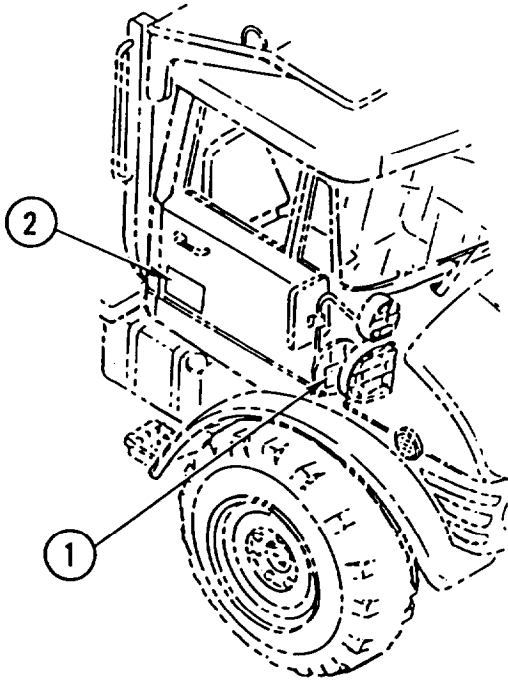

LEGEND

- 1 Identification marker set
- 2 Identification marker
- 3 Identification marker
- 4 Identification marker
- 5 Identification marker
- 6 Backhoe lock decal
- 7 Identification marker

DATA PLATES REPLACEMENT (CONT)

LEGEND

- 1 Folding instructions decal
- 2 Tilt/rotation lock decal
- 3 Electrocution danger decal (2)
- 4 Control CS decal
- 5 Capacity placard (2)
- 6 Danger decal (2)
- 7 Outrigger decal (2)
- 8 Lube chart placard
- 9 Danger decal
- 10 Danger decal
- 11 Danger decal
- 12 Danger decal
- 13 Danger decal
- 14 Danger decal
- 15 Control SS decal

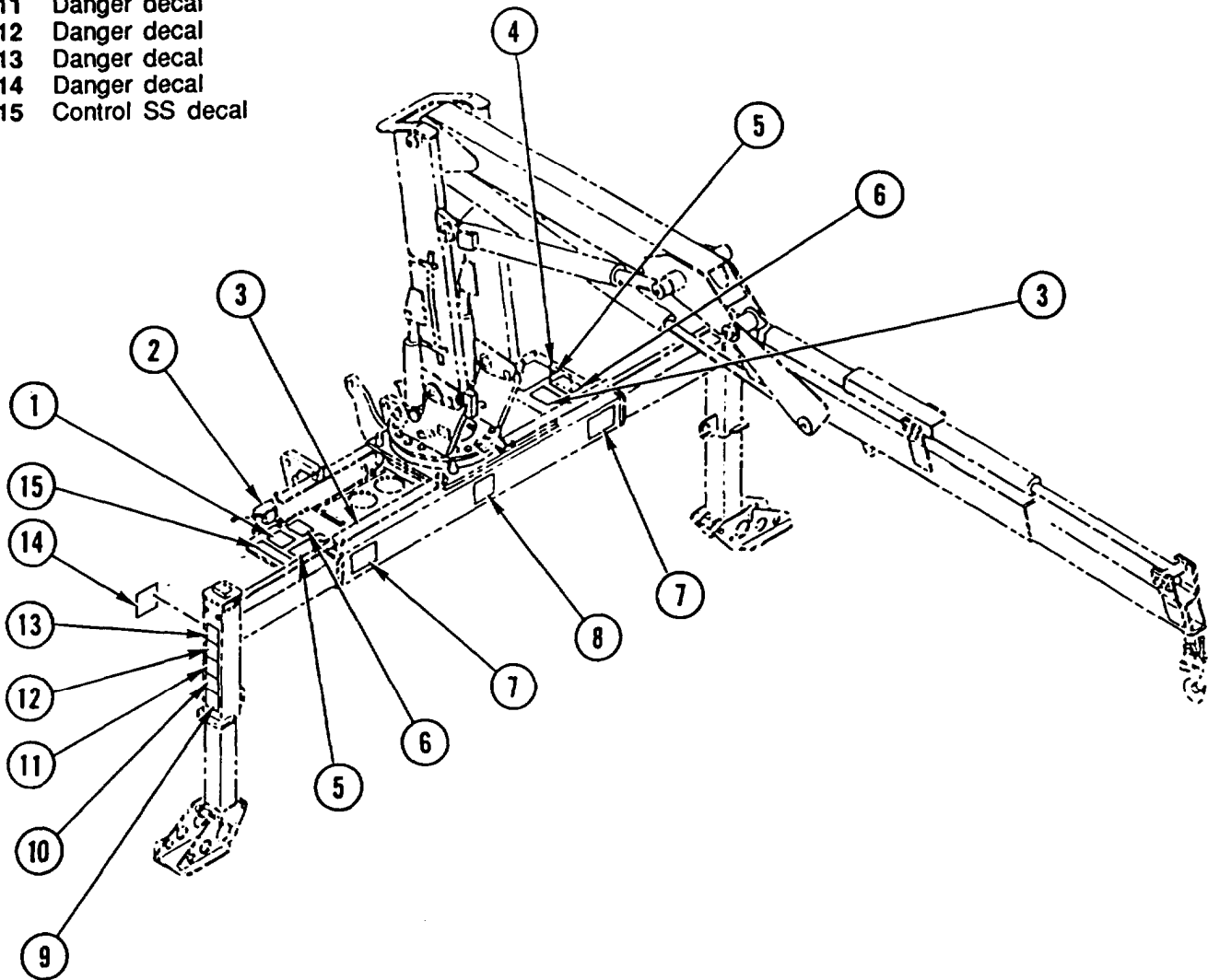

DATA PLATES REPLACEMENT (CONT)

LEGEND

- 1 Lube decal
- 2 Decal (2)
- 3 Decal
- 4 Nameplate
- 5 Decal

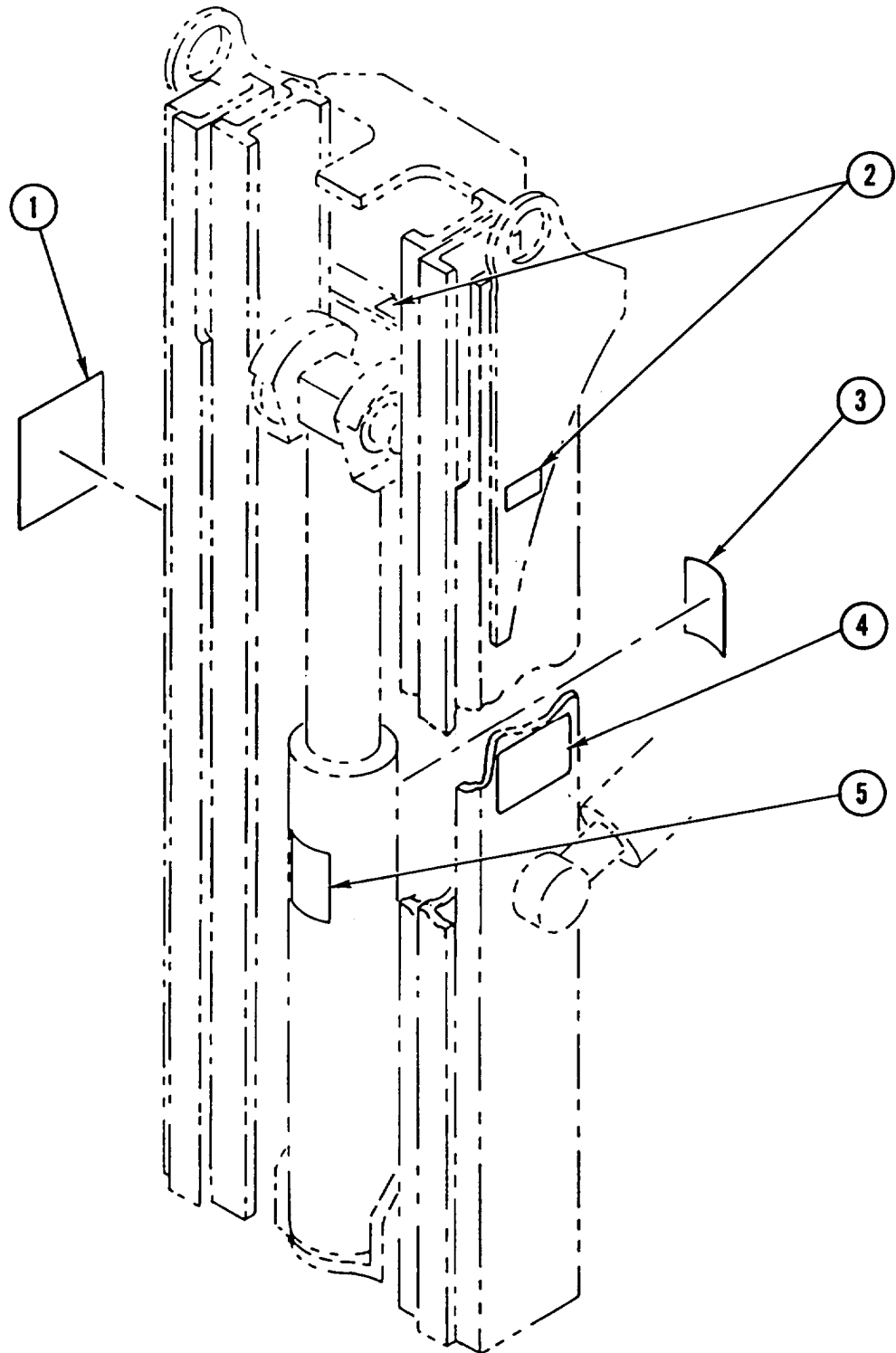

DATA PLATES REPLACEMENT (CONT)

LEGEND

- 1 Identification marker
- 2 Identification marker
- 3 Rivet (4)
- 4 Washer (4)
- 5 Lubrication plate
- 6 Identification marker
- 7 Identification marker
- 8 Label
- 9 Identification marker
- 10 Identification marker

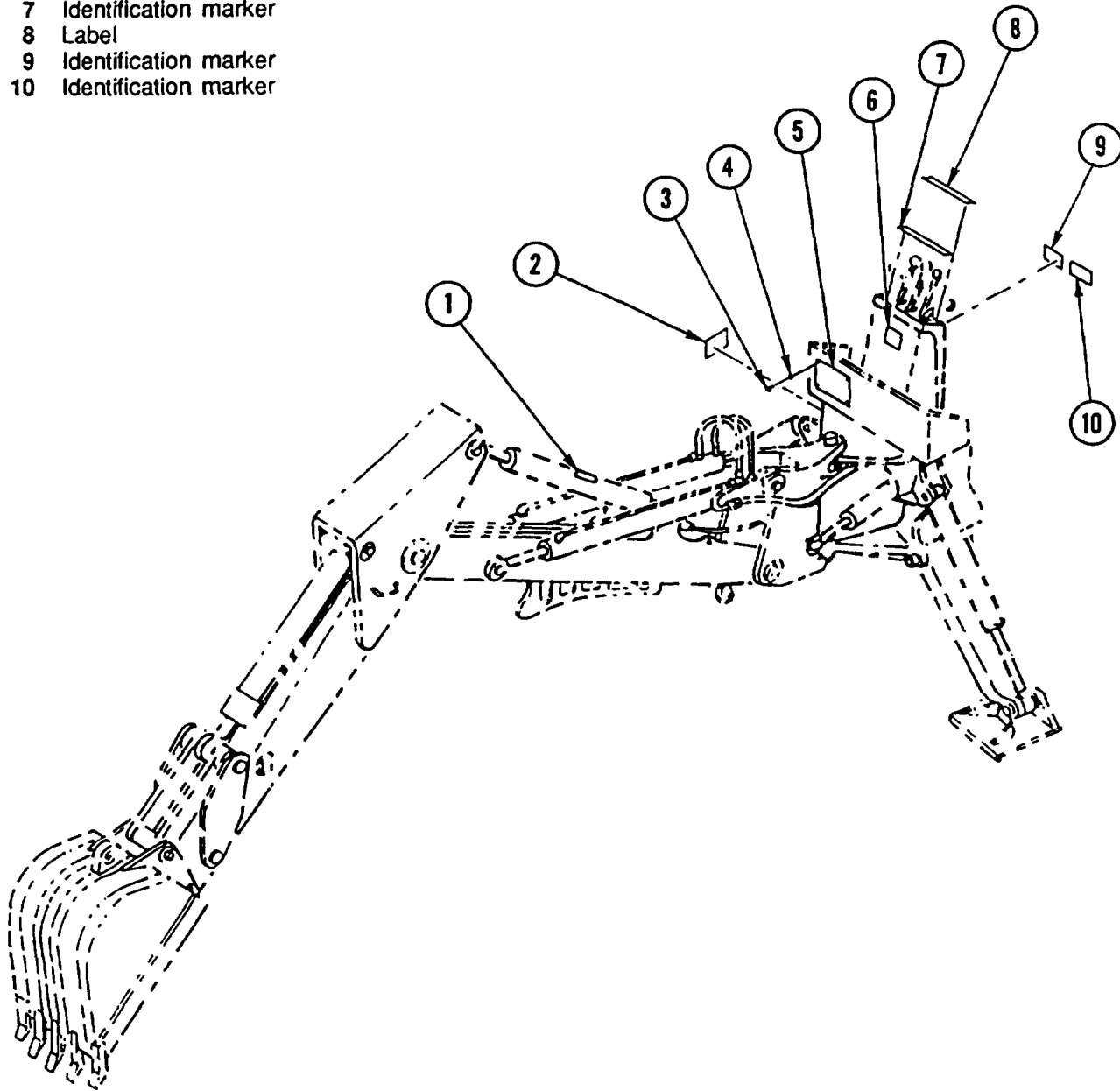

Section XVI. HYDRAULIC SYSTEM MAINTENANCE

OVERVIEW

This section illustrates and describes Procedures for maintenance of the hydraulic system. A list of tasks contained in this section is shown below.

	Page
Front Hydraulic Pump Replacement	4-502
Rear Hydraulic Pump Replacement.	4-504
Front Hydraulic Pump Belt Replacement and Adjustment	4-506
Hydraulic Suspension Lockout Filter Replacement	4-507
Crane Hydraulic Motor Replacement.	4-509
Hydraulic Suspension Lockout Pump Replacement	4-511
Hydraulic Suspension Lockout Accumulator Replacement	4-516
Backhoe Swing Control Pedal Replacement	4-518
Backhoe Swing Control Pedal Adjustment	4-522
Backhoe Control Lever Replacement	4-523
Backhoe Control Rod Adjustment.	4-531
Front Loader/Forklift Control Valve Controls Replacement and Adjustment	4-532
Crane Controls and Linkages Replacement and Adjustment	4-538
Forklift Crosshead Replacement and Adjustment	4-541
Forklift Replacement	4-546
Forklift Rotator Replacement	4-555
Forklift Carriage Chain Adjustment	4-559
Forklift Mast Chain Adjustment	4-562
Forklift Forklift Replacement	4-563
Forklift Travel Lock Replacement	4-566
Forklift Front Outrigger Replacement	4-567
Front Loader Hydraulic Relief Valve Replacement	4-568
Left Loader Boom Cylinder Hydraulic Lines and Fittings Replacement	4-569
Right Loader Boom Cylinder Hydraulic Lines and Fittings Replacement	4-572

	Page
Left Loader Bucket Rollback Cylinder Hydraulic Lines and Fittings Replacement	4-574
Right Loader Bucket Rollback Cylinder Hydraulic Lines and Fittings Replacement	4-576
Front Loader Hydraulic Lines and Fittings Replacement	4-578
Front Loader/Forklift Hydraulic Lines and Fittings Replacement	4-580
Front Loader/Forklift Control Valve Hydraulic Lines and Fittings Replacement	4-582
Front Hydraulic Pump Lines and Fittings Replacement	4-584
Hand Tool Hydraulic Lines and Fittings Replacement	4-586
Front Hydraulic System Return Lines and Fittings Replacement	4-588
Rear Hydraulic Pump Lines and Fittings Replacement	4-590
Rear Hydraulic System Return Lines and Fittings Replacement	4-592
Backhoe/Crane Tilt Cylinder Hydraulic Lines and Fittings Replacement	4-594
Backhoe/Crane Latch Cylinder Hydraulic Lines and Fittings Replacement	4-596
Backhoe/Crane Hydraulic Lines and Fittings Replacement	4-598
Right Backhoe Stabilizer Cylinder Hydraulic Lines and Fittings Replacement	4-600
Left Backhoe Stabilizer Cylinder Hydraulic Lines and Fittings Replacement	4-602
Backhoe Stabilizer Control Valve Hydraulic Lines and Fittings Replacement	4-604
Backhoe Swing Cylinder Hydraulic Lines and Fittings Replacement	4-606
Backhoe Control Valve, Swing Section Hydraulic Lines and Fittings Replacement	4-608
Backhoe Boom Cylinder Hydraulic Lines and Fittings Replacement	4-610
Backhoe Control Valve, Boom Section Hydraulic Lines and Fittings Replacement	4-612
Backhoe Dipper Cylinder Hydraulic Lines and Fittings Replacement	4-614
Backhoe Bucket Cylinder Hydraulic Lines and Fittings Replacement	4-616
Backhoe Control Valve, Bucket Section Hydraulic Lines and Fittings Replacement	4-618
Forklift Tilt Cylinder Hydraulic Lines and Fittings Replacement	4-620
Forklift Hydraulic Lines and Fittings Replacement	4-622
Forklift Rotator Cylinder Hydraulic Lines and Fittings Replacement	4-624
Forklift Pulley Hydraulic Lines and Fittings Replacement	4-626
Forklift Lift Cylinder Hydraulic Lines and Fittings Replacement	4-628

	Page
Forklift Lift Cylinder Bleeding	4-630
Crane External End Extension Cylinder Hydraulic Lines and Fittings Replacement	4-632
Crane Turntable Motor Hydraulic Lines and Fittings Replacement	4-634
Crane Inner Boom Lift Cylinder Hydraulic Lines and Fittings Replacement	4-636
Crane Mast Locking Cylinder Hydraulic Lines and Fittings Replacement	4-638
Crane Supply Lines and Fittings Replacement	4-640
Crane Return Lines and Fittings Replacement	4-642
Crane Outer Boom Cylinder Hydraulic Lines and Fittings Replacement	4-644
Crane Horizontal Outrigger Cylinder Hydraulic Lines and Fittings Replacement	4-646
Crane Vertical Outrigger Cylinder Hydraulic Lines and Fittings Replacement	4-648
Hydraulic Suspension Lockout Lines and Fittings Replacement	4-650
Hydraulic Suspension Lockout Pump and Reservoir Lines and Fittings Replacement . . .	4-652
Loader Boom Cylinder Replacement	4-654
Loader Bucket Rollback Cylinder Replacement	4-656
Backhoe Boom Cylinder Replacement	4-658
Backhoe Swing Cylinder Replacement	4-660
Backhoe Bucket Cylinder Replacement	4-668
Backhoe Dipper Cylinder Replacement	4-670
Backhoe Stabilizer Cylinder Replacement	4-673
Backhoe/Crane Tilt Cylinder Replacement	4-675
Backhoe/Crane Latch Cylinder Mounting Replacement	4-677
Backhoe Travel Lock Replacement and Repair	4-678
Backhoe Travel Lock Replacement and Repair	4-681
Backhoe/Crane Latch Cylinder Replacement	4-684
Forklift Tilt Cylinder Replacement.	4-686
Forklift Rotator Cylinder Replacement	4-688
Crane External End Extension Cylinder Replacement	4-690
Crane Inner Boom Lift Cylinder Replacement	4-692

	Page
Crane Mast Locking Cylinder Replacement	4-694
Crane Outer Boom Cylinder Replacement	4-696
Crane Horizontal Outrigger Cylinder Replacement	4-698
Crane Vertical Outrigger Cylinder Replacement	4-700
Front Hydraulic Tank Replacement and Repair	4-702
Front Hydraulic Tank Filter Replacement	4-709
Rear Hydraulic Tank Replacement and Repair	4-712
Hydraulic Tank Sight Indicator Replacement	4-719
Rear Hydraulic Tank Filter Replacement	4-720
Hydraulic Oil Cooler Replacement	4-722

FRONT HYDRAULIC PUMP REPLACEMENT

This task covers: a. Removal b. Installation

INITIAL SETUP

Tools and Special Equipment:

Shop Equipment, SC 4910-95-CL-A74
 Tool Kit, SC 5180-90-CL-N26

Materials/Parts:

Packing
 Packing
 Washer, Lock
 Caps and Plugs Appendix C, Item 7
 Rags Appendix C, Item 32

Equipment Condition:

Reference	Condition Description
Page 4-385	Front Plate Removed
Page 2-23	Hydraulic Pressure Relieved

General Safety Instructions:

W A R N I N G

- High pressure hydraulics [oil under 2450 psi (16,893 kPa)] operate this equipment. Never disconnect any hydraulic line or fitting without first dropping pressure to zero. A high pressure oil stream can pierce body and cause severe injury to personnel.
- Fuel and oil are slippery and can cause falls. To avoid injury, wipe up spilled fuel or oil with rags.

FRONT HYDRAULIC PUMP REPLACEMENT (CONT)

REMOVAL

CAUTION

Cap or plug all ports and ends of hoses and tubes to prevent contamination of hydraulic oil. Failure to do so may result in damage to equipment.

NOTE

Tag lines prior to disconnecting to aid in connecting.

1. DISCONNECT two hydraulic hoses (1 and 2). INSTALL CAPS or PLUGS.
2. LOOSEN NUT (3) and TURN SCREW (4) to disconnect belt (5).
3. REMOVE bolt (6), washer (7), nut (8), and front hydraulic PUMP (9). INSTALL CAPS or PLUGS on hydraulic fittings on pump (9).
4. REMOVE eight screws (10), two ADAPTERS (11 and 12), and two packings (13). DISCARD PACKINGS.
5. REMOVE nut (14), lock washer (15), key (16), and PULLEY (17). DISCARD lock WASHER.

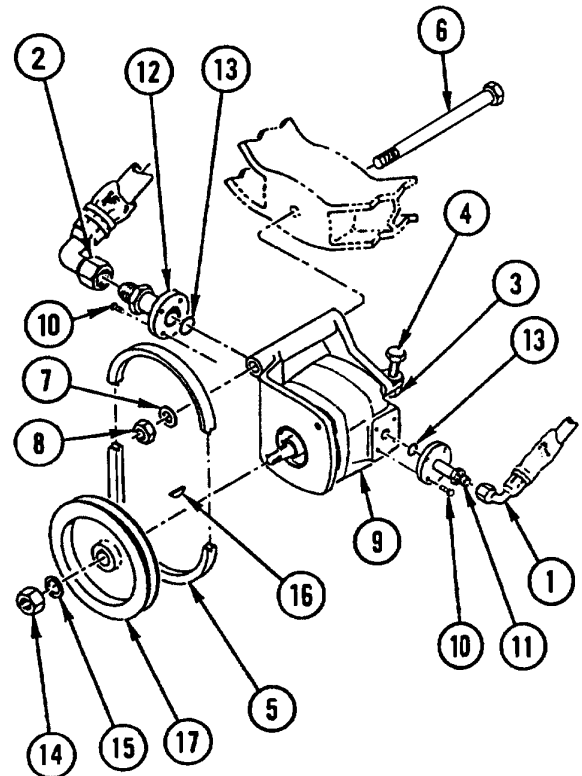
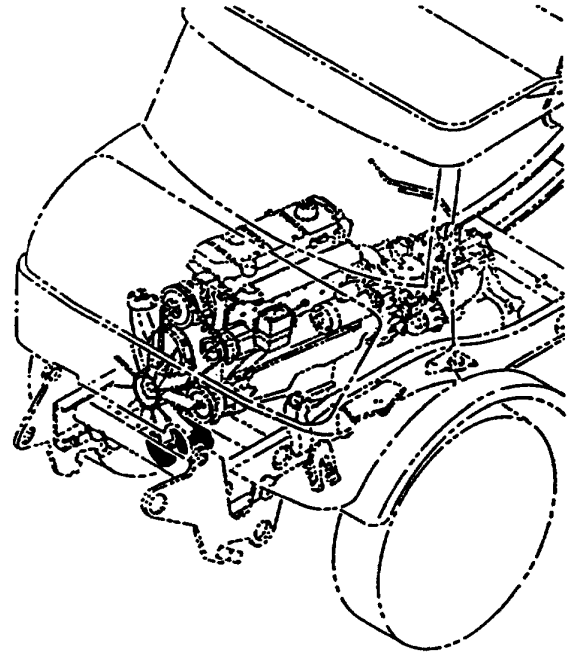

FRONT HYDRAULIC PUMP REPLACEMENT (CONT)

INSTALLATION

NOTE

New style pump does not have key-way on shaft.

Ensure pump shaft and pulley are clean and free of paint.

1. INSTALL two new packings (13), two ADAPTERS (11 and 12), and eight screws (10) on front hydraulic pump (9).
2. INSTALL key (16), PULLEY (17), new lock washer (15), and nut (14).
3. INSTALL front hydraulic PUMP (9), bolt (6), nut (8), and washer (7). REMOVE CAPS or PLUGS from hydraulic fittings on pump (9).
- 3.1. When installing new pump, tighten nut (14) to 52 lb-ft (71 N-m) on M12 x 1.5 nut or 77 lb-ft (104 N-m) on M14 x 1.5 nut.
4. CONNECT BELT (5).
5. ADJUST FRONT HYDRAULIC PUMP BELT (page 4-506).
6. REMOVE CAPS or PLUGS. CONNECT two hydraulic HOSES (1 and 2).

NOTE

Follow-on Maintenance:
Install front plate (page 4-385).

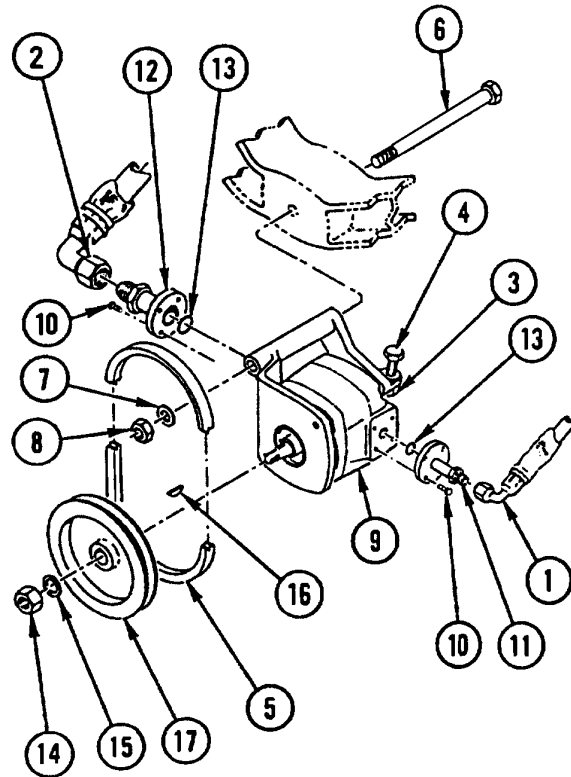
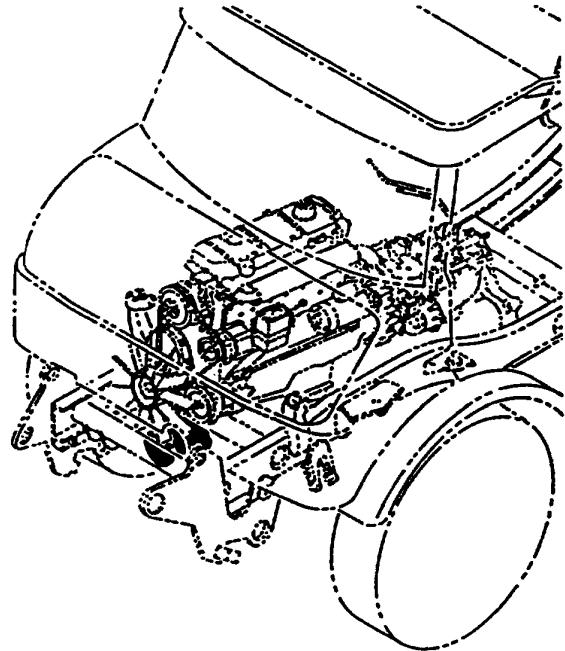

REAR HYDRAULIC PUMP REPLACEMENT

This task covers: a. Removal b. Installation

INITIAL SETUP

Tools and Special Equipment:

Shop Equipment, SC 4910-95-CL-A74
 Tool Kit, SC 5180-90-CL-N26

Materials/Parts:

Washer, Lock (8)

Packing

Packing

Caps and Plugs Appendix C, Item 7

Rags Appendix C, Item 32

References:

None

Equipment Condition:

Reference	Condition Description
Page 2-14	Rear Hydraulic Tank Drained
Page 4-418	Cab Tilted
Page 2-23	Hydraulic Pressure Relieved

General Safety Instructions:

WARNING

- High pressure hydraulics [oil under 2450 psi (16,893 kPA)] operate this equipment. Never disconnect any hydraulic line or fitting without first dropping pressure to zero. A high pressure oil stream can pierce body and cause severe injury to personnel.
- Fuel and oil are slippery and can cause falls. To avoid injury, wipe up spilled fuel or oil with rags.

REMOVAL

1. REMOVE eight capscrews (1), eight lock washers (2), eight washers (3), and four pipe FLANGES (4). DISCARD lock WASHERS.

CAUTION

Cap or plug all ports and ends of hose and tubes to prevent contamination of hydraulic oil. Failure to do so may result in damage to equipment.

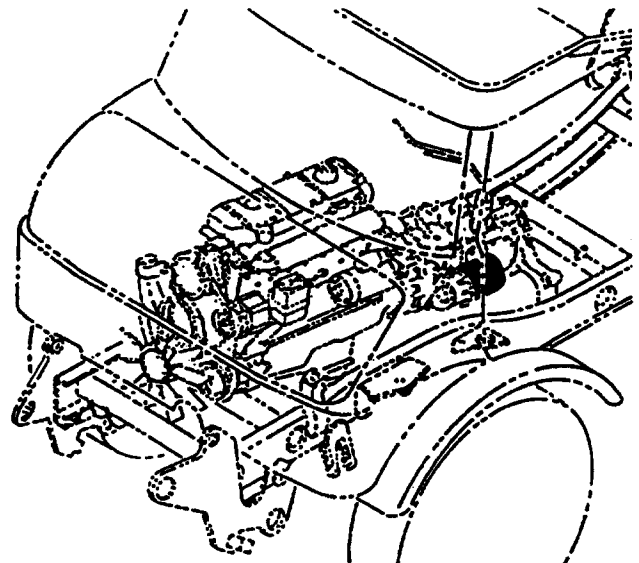

REAR HYDRAULIC PUMP REPLACEMENT (CONT)

NOTE

Tag lines prior to disconnecting to aid in connecting.

2. DISCONNECT two HOSE assemblies (5) and REMOVE two PACKINGS (6). INSTALL CAPS or PLUGS. DISCARD PACKINGS.
3. REMOVE two bolts (7) and rear hydraulic PUMP (8), INSTALL CAPS or PLUGS in inlet/outlet sides of pump (8).

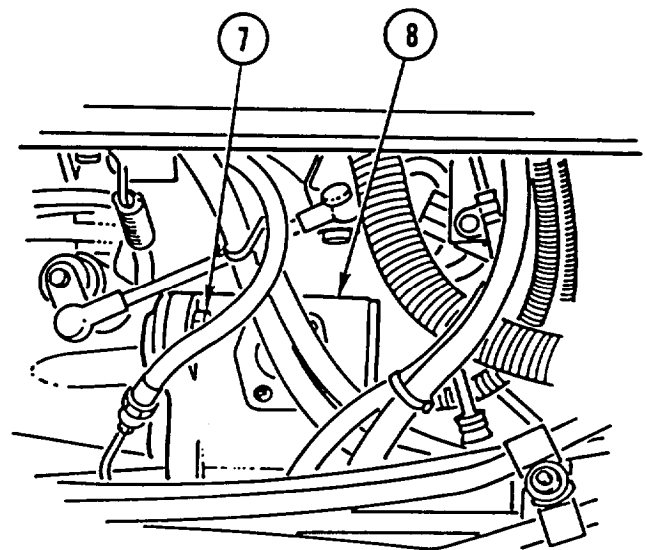
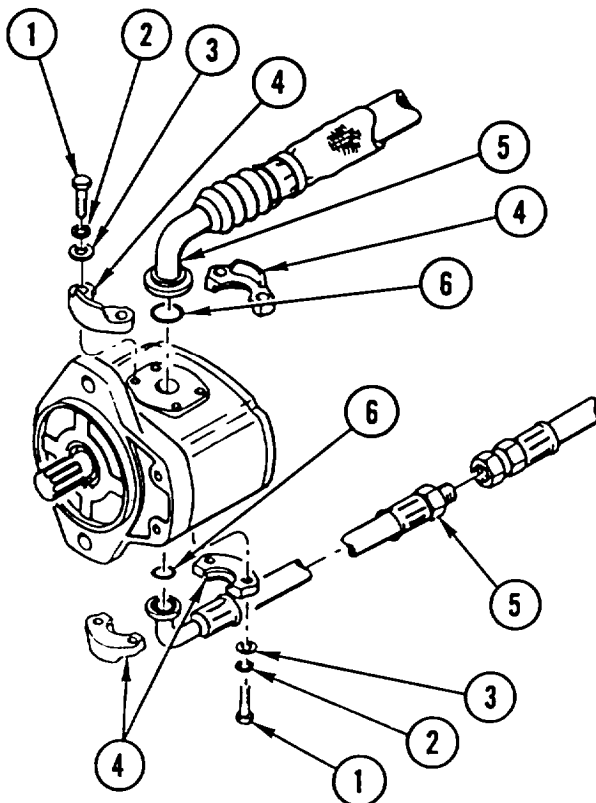

INSTALLATION

1. REMOVE CAPS or PLUGS from inlet/outlet sides of rear hydraulic pump (8). INSTALL PUMP (8) and two bolts (7).
2. INSTALL two new PACKINGS (6). REMOVE CAPS or PLUGS. CONNECT two HOSE assemblies (5).
3. INSTALL four pipe FLANGES (4), eight new washers (3), eight lock washers (2), and eight capscrews (1).

NOTE

Follow-on Maintenance:

Lower cab (page 4-418).
 Fill rear hydraulic tank (page 2-14).

FRONT HYDRAULIC PUMP BELT REPLACEMENT AND ADJUSTMENT

This task covers: a. Removal b. Installation/Adjustment

INITIAL SETUP

Tools and Special Equipment:

Shop Equipment, SC 4910-95-CL-A74
Tool Kit, SC 5180-90-CL-N26

Equipment Condition:

Reference

Page 4-356

Condition Description

Power Steering Pump
Belt Removed

REMOVAL

1. LOOSEN NUT ON END OF BOLT (1).
2. LOOSEN NUT (2) and TURN SCREW (3) to loosen belt (4).
3. REMOVE BELT (4).

INSTALLATION/ADJUSTMENT

1. INSTALL BELT (4).
2. TURN SCREW (3) to tighten tension on belt (4).
3. APPLY THUMB PRESSURE on belt and continue to TIGHTEN until bow in belt is 0.39-0.59 in. (10-15 mm).
4. TIGHTEN NUT (2).
5. TIGHTEN NUT ON END OF BOLT (1).

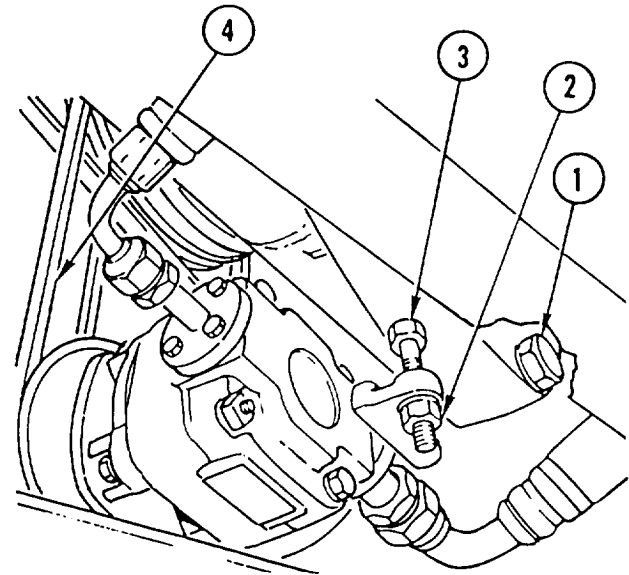

NOTE

Follow-on Maintenance:
Install power steering pump belt
(page 4-356).

HYDRAULIC SUSPENSION LOCKOUT FILTER REPLACEMENT

This task covers: a. Removal b. Installation

INITIAL SETUP

Applicable Configuration:

HMMH

Tools and Special Equipment:

Shop Equipment, SC 4910-95-CL-A74
 Tool Kit, SC 5180-90-CL-N26

Materials/Parts:

Ring, Seal

Caps and Plugs Appendix C, Item 7

Rags Appendix C, Item 32

References:

TM 5-2420-224-10

Equipment Condition:

Reference

TM 5-2420-224-10

Condition Description

Suspension Lockout
 System Disengaged

General Safety Instructions:

W A R N I N G

- High pressure hydraulics [oil under 2450 psi (16,893 kPa)] operate this equipment. Never disconnect any hydraulic line or fitting without first dropping pressure to zero. A high pressure oil stream can pierce body and cause severe injury to personnel.
- Fuel and oil are slippery and can cause falls. To avoid injury, wipe up spilled fuel or oil with rags.

HYDRAULIC SUSPENSION LOCKOUT FILTER REPLACEMENT (CONT)

REMOVAL

CAUTION

Cap or plug all ports and ends of hoses and tubes to prevent contamination of hydraulic oil. Failure to do so may result in damage to equipment.

NOTE

Tag lines prior to disconnecting to aid in connecting.

1. DISCONNECT two hydraulic HOSES (1). INSTALL CAPS or PLUGS.
2. REMOVE CONNECTOR (2) and seal ring (3). DISCARD seal RING.
3. REMOVE check VALVE (4).
4. REMOVE two bolts (5) and filter BODY (6).
5. REMOVE filter ELEMENT (7) from filter body (6).

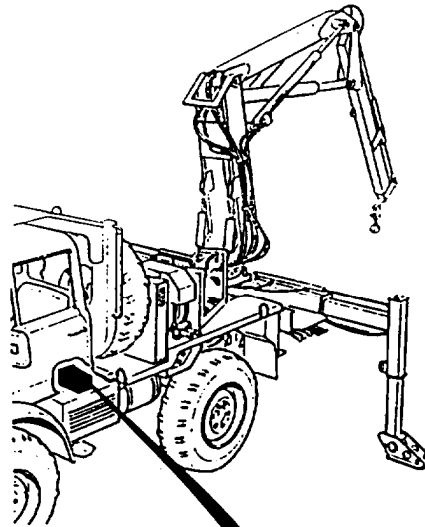

INSTALLATION

1. INSTALL filter ELEMENT (7) in filter body (6).
2. INSTALL filter BODY (6) and two bolts (5).
3. INSTALL check VALVE (4).
4. INSTALL new seal ring (3) and CONNECTOR (2).
5. REMOVE CAPS or PLUGS. CONNECT two hydraulic HOSES (1).

NOTE

Follow on Maintenance:
Check hydraulic suspension lockout reservoir (page 2-14).

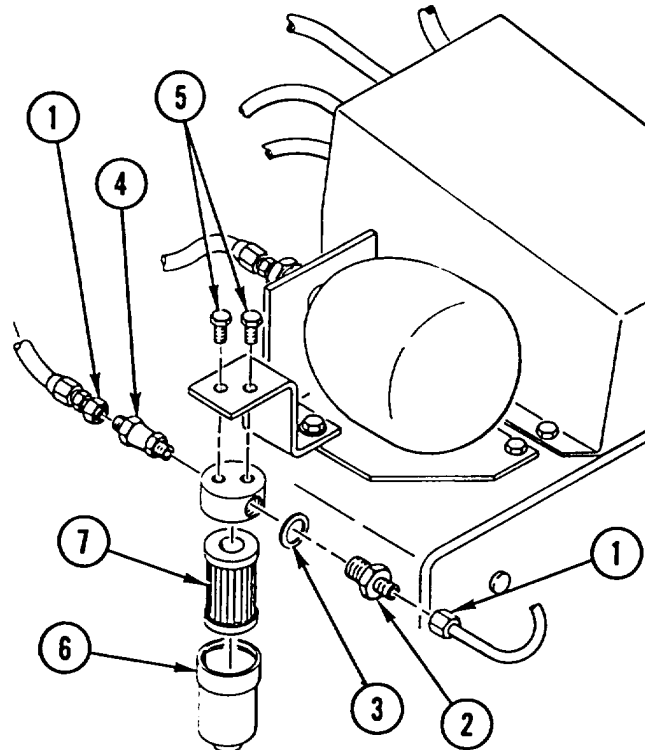

CRANE HYDRAULIC MOTOR REPLACEMENT

This task covers: a. Removal b. Installation

INITIAL SETUP

Applicable Configuration:

HMMH

Tools and Special Equipment:

Shop Equipment, SC 4910-95-CL-A74
 Tool Kit, SC 5180-90-CL-N26

Materials/Parts:

Nut, Lock (2)

Packing (2)

Caps and Plugs Appendix C, item 7

Rags Appendix C, item 32

References:

TM 5-2420-224-10

Equipment Condition:

Reference	Condition Description
Page 2-23	Crane in Three-Point Stance
Page 2-23	Hydraulic Pressure Relieved

General Safety Instructions:

W A R N I N G

- High pressure hydraulics [oil under 2450 psi (16,893 kPa)] operate this equipment. Never disconnect any hydraulic line or fitting without first dropping pressure to zero. A high pressure oil stream can pierce body and cause severe injury to personnel.
- To prevent possible injury to personnel, make sure crane is in a three-point stance. If not, crane assembly will swing to either side when hydraulic motor is removed.
- Fuel and oil are slippery and can cause falls. To avoid injury, wipe up spilled fuel or oil with rags.

CRANE HYDRAULIC MOTOR REPLACEMENT (CONT)

REMOVAL

CAUTION

Cap or plug all ports and ends of hoses and tubes to prevent contamination of hydraulic oil. Failure to do so may result in damage to equipment.

NOTE

Tag lines prior to disconnecting to aid in connecting.

1. DISCONNECT two hydraulic HOSES (1 and 2). INSTALL CAPS or PLUGS.
2. REMOVE two lock nuts (3) and crane hydraulic MOTOR (4). DISCARD LOCK NUTS.
3. REMOVE four capscrews (5), BLOCK (6), and two packings (7). DISCARD PACKINGS.
4. REMOVE two CARTRIDGES (8).

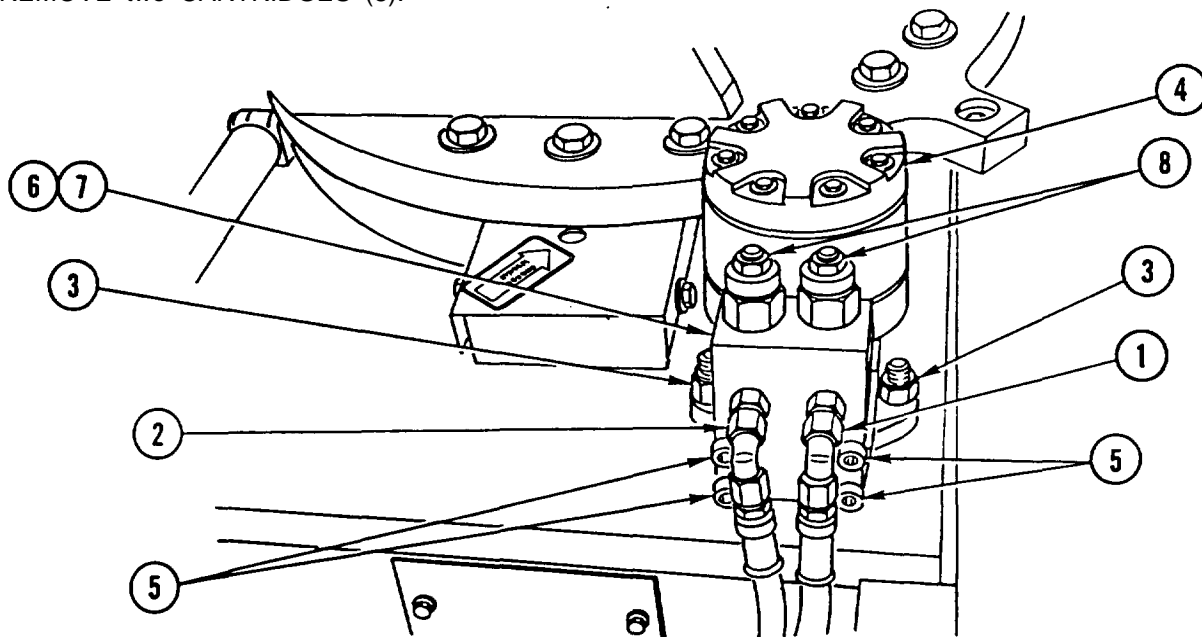

INSTALLATION

1. INSTALL two CARTRIDGES (8).
2. INSTALL two new packings (7), BLOCK (6), and four capscrews (5).
3. INSTALL crane hydraulic MOTOR (4) and two new lock nuts (3).
4. REMOVE CAPS or PLUGS. CONNECT two hydraulic HOSES (1 and 2).

NOTE

Follow on Maintenance:
Check rear hydraulic tank (TM 5-2420-224-10).

HYDRAULIC SUSPENSION LOCKOUT PUMP REPLACEMENT

This task covers: a. Removal b. Installation

INITIAL SETUP

Applicable Configuration:

HMMH

Tools and Special Equipment:

Shop Equipment, SC 4910-95-CL-A74
 Tool Kit, SC 5180-90-CL-N26

Materials/Parts:

Nut, Lock (2)

Ring, Seal (6)

Caps and Plugs Appendix C, Item 7

Rags Appendix C, Item 32

References:

TM 5-2420-224-10

Equipment Condition:

Reference	Condition Description
TM 5-2420-224-10	Suspension Lockout System Disengaged

General Safety Instructions:

W A R N I N G

- High pressure hydraulics [oil under 2450 psi (16,893 kPa)] operate this equipment. Never disconnect any hydraulic line or fitting without first dropping pressure to zero. A high pressure oil stream can pierce body and cause severe injury to personnel.
- Do not connect or disconnect any electrical connector unless vehicle MASTER disconnect switch is OFF. To do so could result in injury to personnel.
- Fuel and oil are slippery and can cause falls. To avoid injury, wipe up spilled fuel or oil with rags.

HYDRAULIC SUSPENSION LOCKOUT PUMP REPLACEMENT (CONT)

REMOVAL

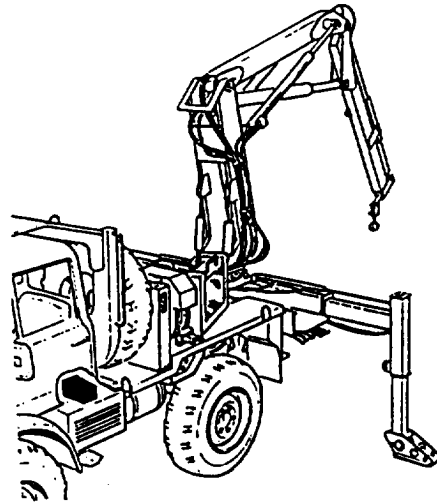

1. REMOVE four bolts (1), two lock nuts (2), six washers (3), and COVER (4). DISCARD lock NUTS.

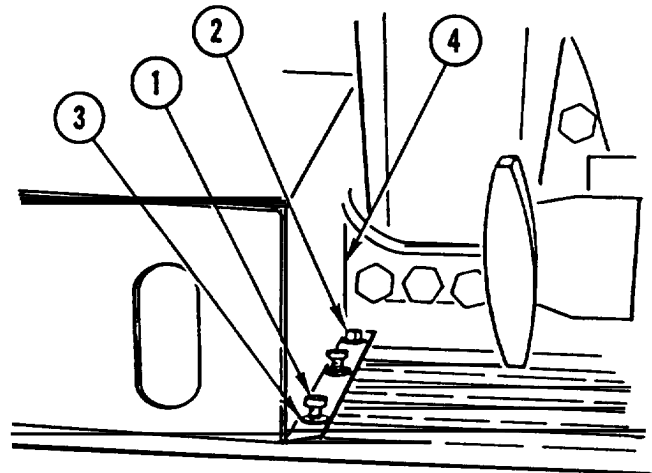

CAUTION
 Cap or plug all ports and ends of hoses and tubes to prevent contamination of hydraulic oil. Failure to do so may result in damage to equipment.

NOTE

Tag lines prior to disconnecting to aid in connecting.

2. REMOVE two fluid passage BOLTS (5) and four seal rings (6) and DISCONNECT two hydraulic HOSES (7). INSTALL CAPS or PLUGS. DISCARD seal RINGS.
3. REMOVE fluid passage BOLT (8) and two seal rings (9) and DISCONNECT vent HOSE (10). DISCARD seal RINGS.

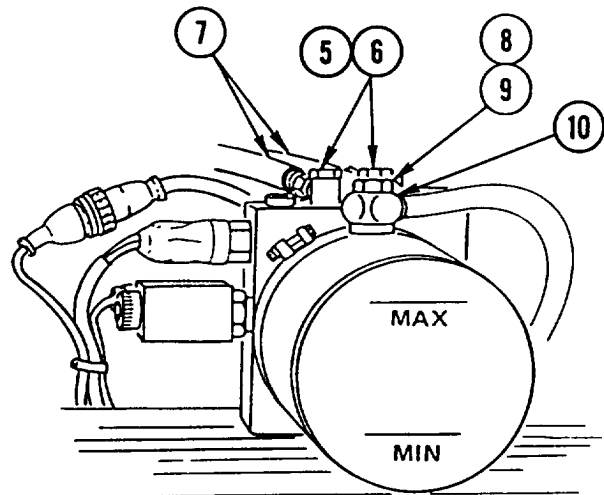

HYDRAULIC SUSPENSION LOCKOUT PUMP REPLACEMENT (CONT)

NOTE

Tag all electrical connectors prior to disconnecting to aid in connecting.

4. CAREFULLY ROLL BACK rubber COVER (11) and DISCONNECT two electrical CONNECTORS (12).
5. DISCONNECT electrical CONNECTOR (13).

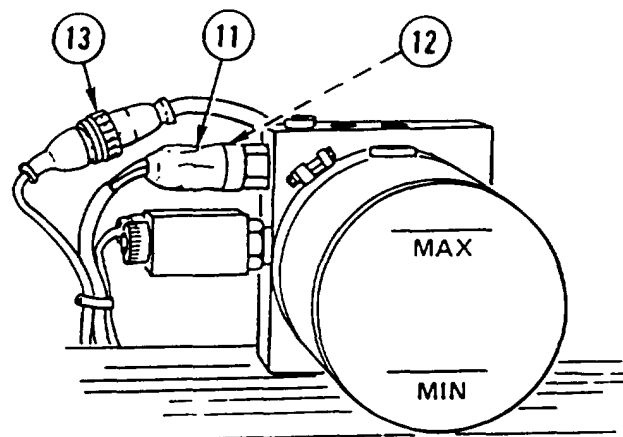

6. REMOVE two screws (14), two washers (15), bracket (16), and hydraulic suspension lockout PUMP (17).

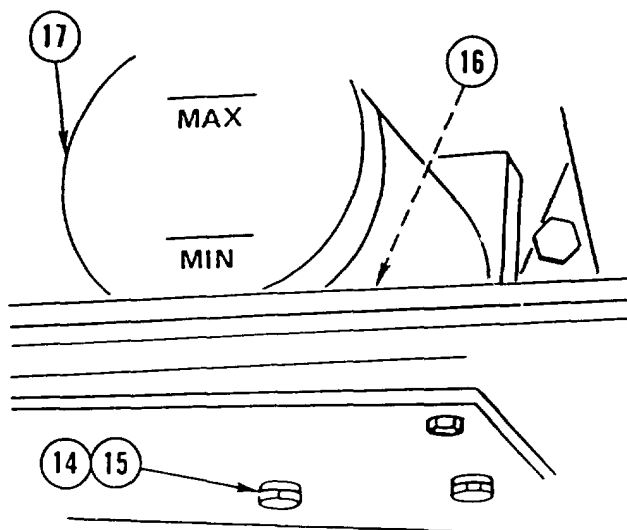

7. REMOVE SCREW (18) and DISCONNECT electrical CONNECTOR (19) from solenoid (20).

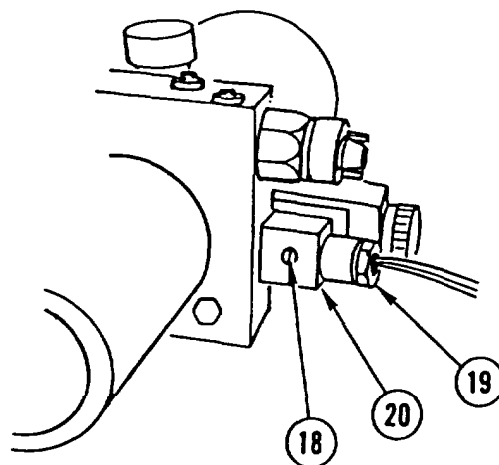

HYDRAULIC SUSPENSION LOCKOUT PUMP REPLACEMENT (CONT)

1. CONNECT electrical CONNECTOR (1) and INSTALL SCREW (2) in solenoid (3).

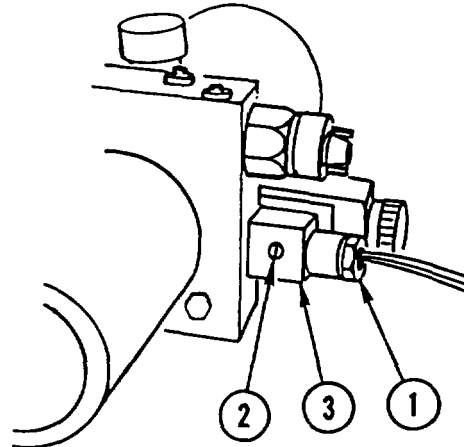

2. INSTALL hydraulic suspension lockout PUMP (4), bracket (5), two washers (6), and two screws (7).

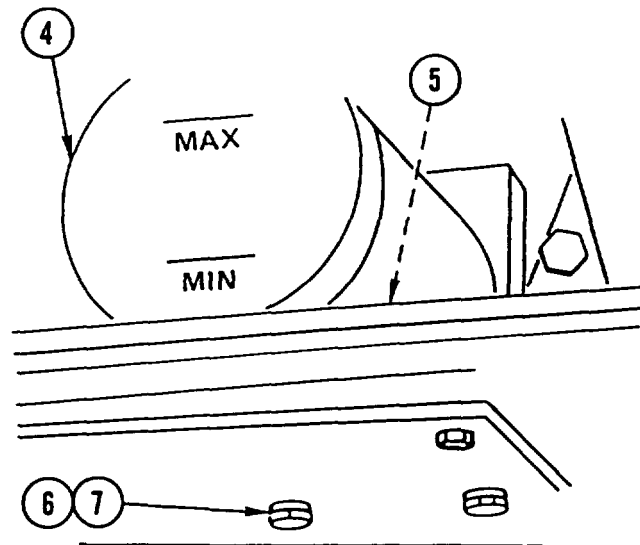

3. CONNECT electrical CONNECTOR (8).
4. CONNECT two electrical CONNECTORS (9) and CAREFULLY ROLL rubber COVER (10) back in place.

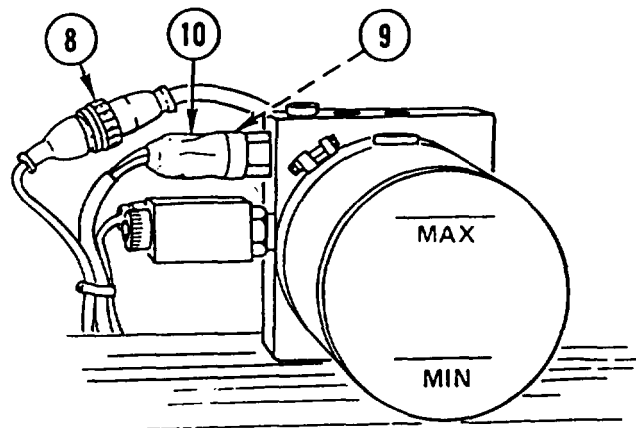

HYDRAULIC SUSPENSION LOCKOUT PUMP REPLACEMENT (CONT)

5. CONNECT vent HOSE (11) and INSTALL fluid passage BOLT (12) and two new seal rings (13).
6. REMOVE CAPS or PLUGS. CONNECT two hydraulic HOSES (14). INSTALL two fluid passage BOLTS (15) and four new seal rings (16).

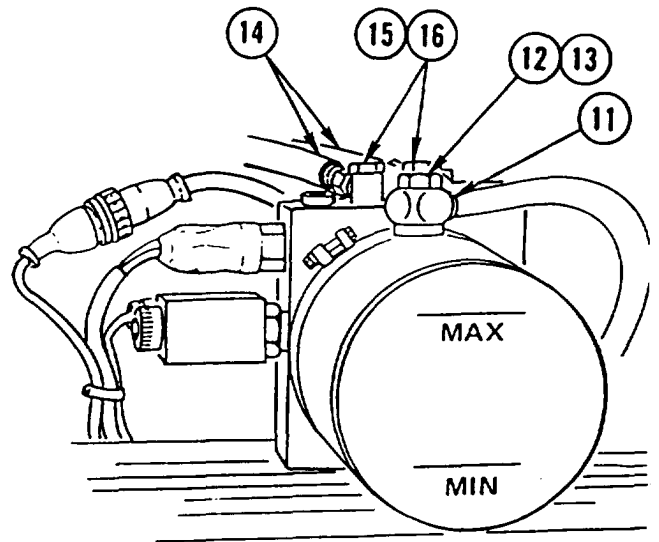

7. INSTALL COVER (17), six washers (18), two new lock nuts (19), and four bolts (20).

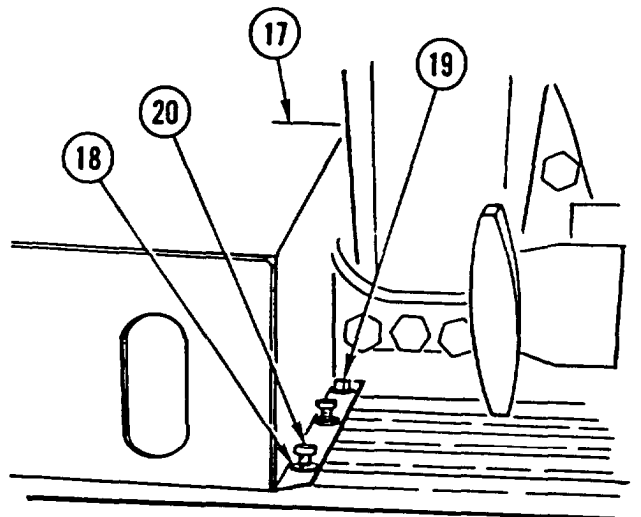

HYDRAULIC SUSPENSION LOCKOUT ACCUMULATOR REPLACEMENT

This task covers: a. Removal b. Installation

INITIAL SETUP

Applicable Configuration:

HMMH

Tools and Special Equipment:

Tool Kit, SC 5180-90-CL-N26

Materials/Parts:

Packing

Caps and Plugs Appendix C, Item 7

Rags Appendix C, Item 32

References:

TM 5-2420-224-10

Equipment Condition:

Reference	Condition Description
TM 5-2420-224-10	Suspension Lockout System Disengaged

General Safety Instructions:

W A R N I N G

- High pressure hydraulics [oil under 2450 psi (16,893 kPa)] operate this equipment. Never disconnect any hydraulic line or fitting without first dropping pressure to zero. A high pressure oil stream can pierce body and cause severe injury to personnel.
- Fuel and oil are slippery and can cause falls. To avoid personal injury, wipe up spilled fuel or oil with rags.

REMOVAL

CAUTION

Cap or plug all ports and ends of hoses and tubes to prevent contamination of hydraulic oil. Failure to do so may result in damage to equipment.

1. DISCONNECT hydraulic HOSE (1). INSTALL CAP or PLUG.
2. REMOVE REDUCER (2) and packing (3). DISCARD PACKING.
3. REMOVE nut (4) and hydraulic suspension lockout ACCUMULATOR (5).

INSTALLATION

1. INSTALL hydraulic suspension lockout ACCUMULATOR (5) and nut (4).
2. INSTALL new packing (3) and REDUCER (2).
3. REMOVE CAP or PLUG. CONNECT hydraulic HOSE (1).

**HYDRAULIC SUSPENSION LOCKOUT ACCUMULATOR REPLACEMENT
(CONT)**

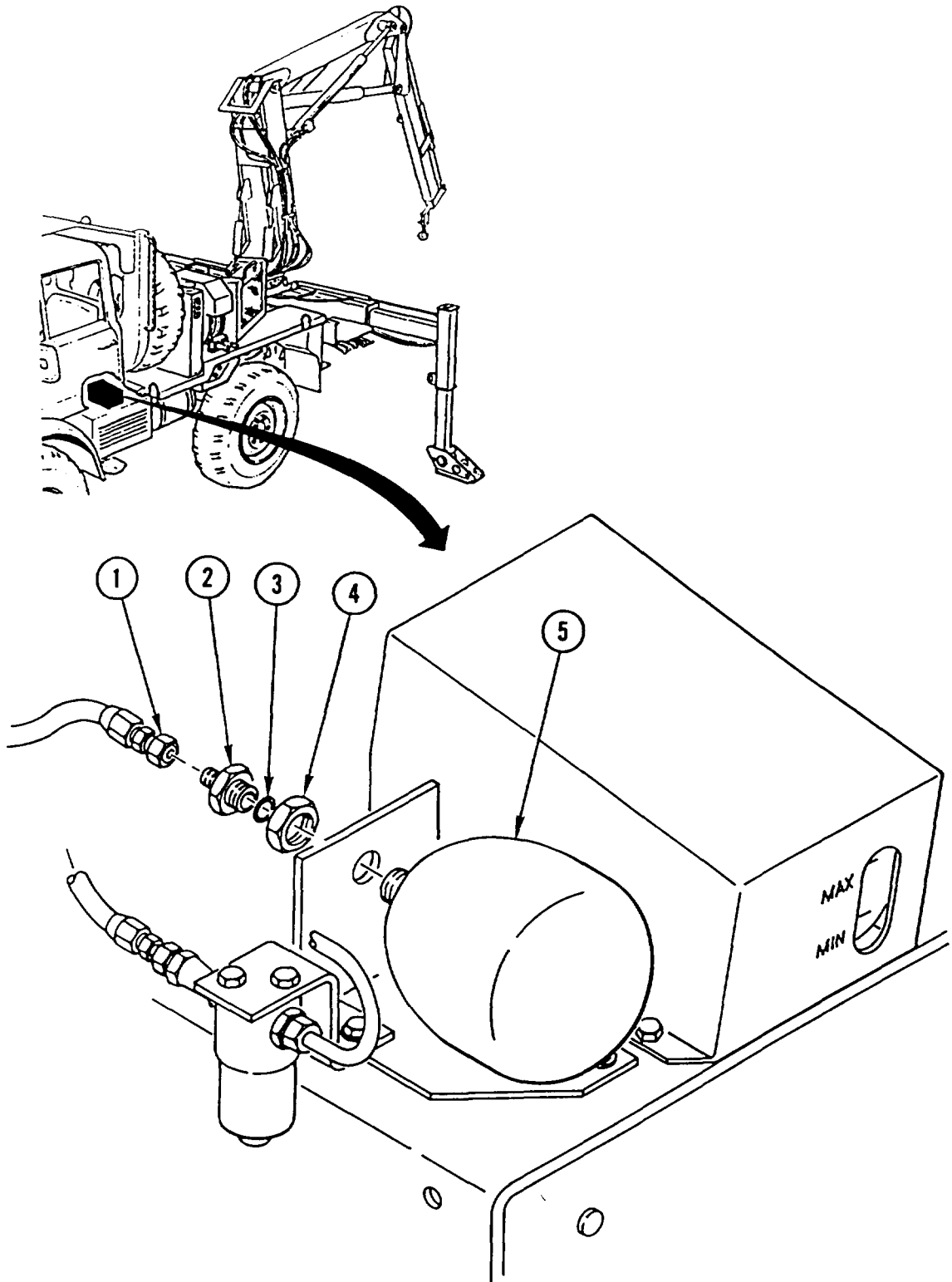

BACKHOE SWING CONTROL PEDAL REPLACEMENT

This task covers: a. Removal b. Installation

INITIAL SETUP

Applicable Configuration:

SEE

Tools and Special Equipment:

Shop Equipment, SC 4910-95-CL-A74
Tool Kit, SC 5180-90-CL-N26

Equipment Condition:

Reference

Page 2-22

Page 4-444

Condition Description

Backhoe in Three-Point
Stance

Backhoe Seat Removed

Materials/Parts:

Screw, Self-Tapping (3)

Pin, Cotter (2)

Washer, Lock (4)

REMOVAL

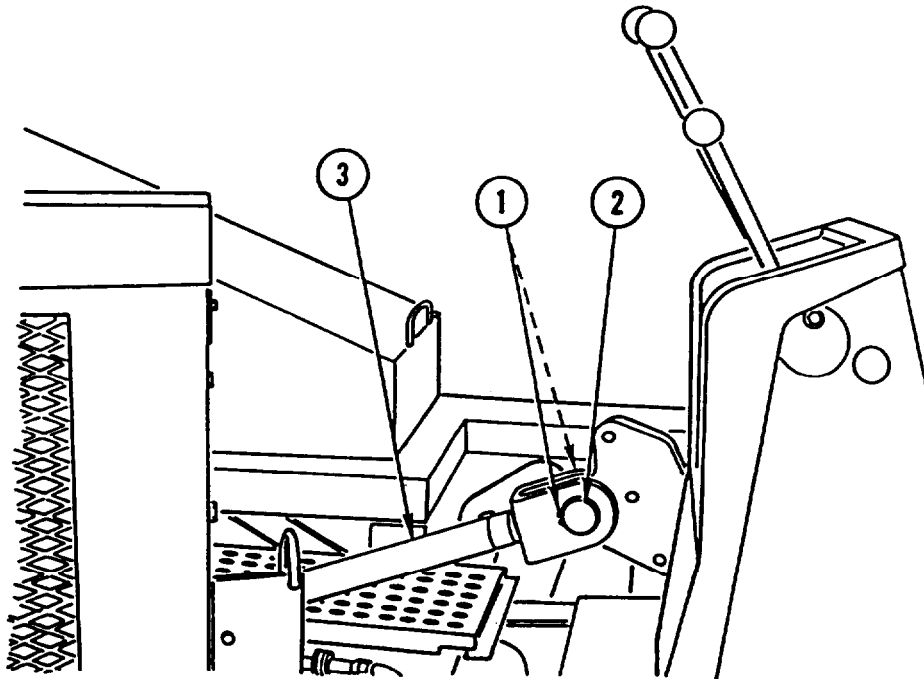

1. REMOVE two retaining rings, (1) and PIN (2) and SECURE tilt CYLINDER (3) out of the way.

BACKHOE SWING CONTROL PEDAL REPLACEMENT (CONT)

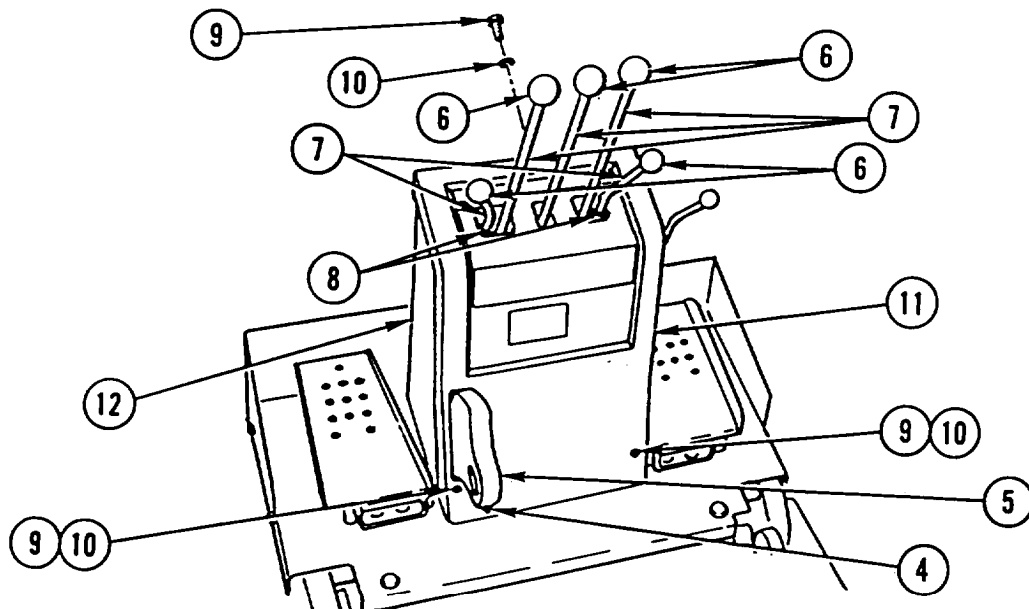

2. REMOVE grease FITTING (4) from bracket (5).
3. REMOVE five KNOBS (6) from five control levers (7).
4. LOOSEN two NUTS (8) and ROTATE two outer control LEVERS (7) in toward center.
5. REMOVE three self-tapping screws (9), three washers (10), and COVER (11) from control tower (12). DISCARD self-tapping SCREWS.

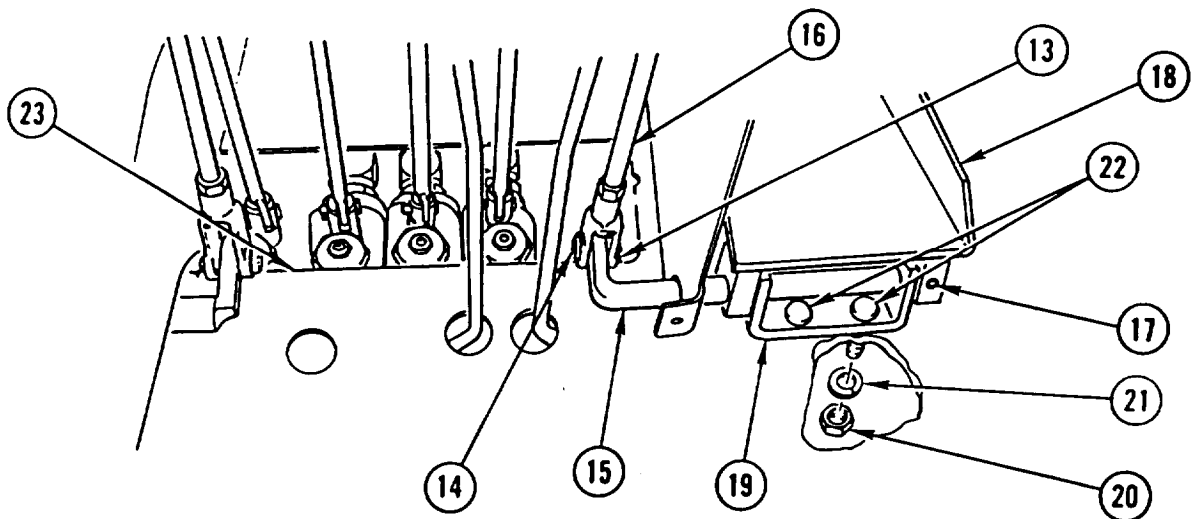

6. REMOVE cotter pin (13) and PIN (14) from shaft (15) and control rod (16). DISCARD rotter PIN.
7. REMOVE setscrew (17), shaft (15), and backhoe swing control PEDAL (18) from mounting bracket (19).
8. REMOVE two nuts (20), two lock washers (21), two screws (22), and mounting BRACKET (19) from plate assembly (23). DISCARD lock WASHERS.
9. REPEAT STEPS 6 thru 8 for opposite backhoe swing control pedal.

BACKHOE SWING CONTROL PEDAL REPLACEMENT (CONT)

INSTALLATION

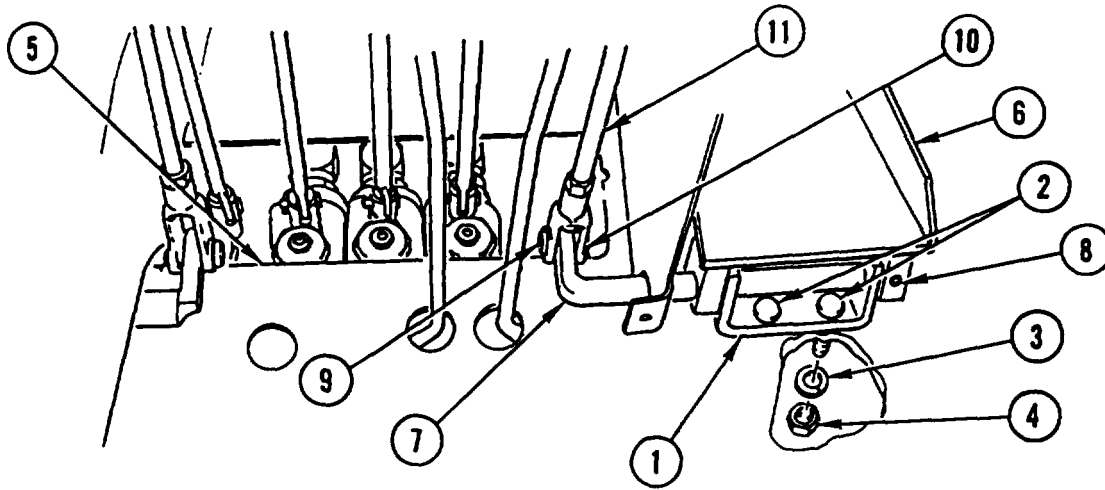

1. INSTALL mounting BRACKET (1), two screws (2), two new lock washers (3), and two nuts (4) on plate assembly (5).
2. INSTALL backhoe swing control PEDAL (6), shaft (7), and setscrew (8) on mounting bracket (1).
3. INSTALL PIN (9) and new cotter pin (10) through shaft (7) and control rod (11).
4. REPEAT STEPS 1 thru 3 for opposite backhoe swing control pedal.

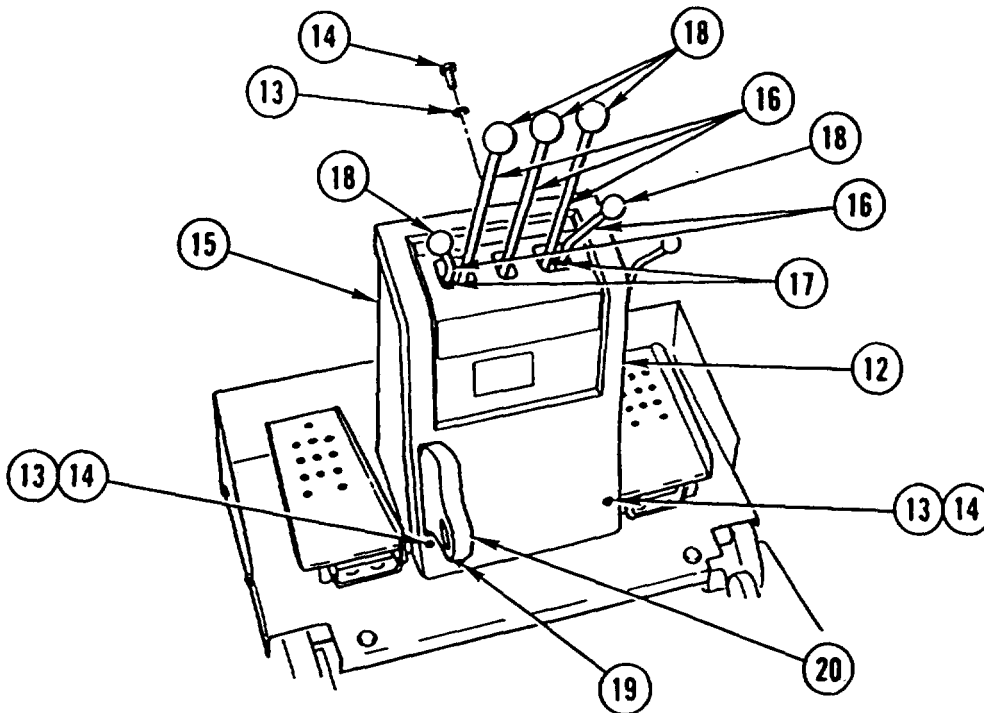

BACKHOE SWING CONTROL PEDAL REPLACEMENT (CONT)

NOTE

If needed, adjust control pedals at this time (page 4-522).

5. INSTALL COVER (12), three washers (13), and three new self-tapping screws (14) in control tower (15).
6. ROTATE two outer control LEVERS (16) OUTWARD from center and TIGHTEN two NUTS (17).
7. INSTALL five KNOBS (18) on five control levers (16).
8. INSTALL grease FITTING (19) in bracket (20).

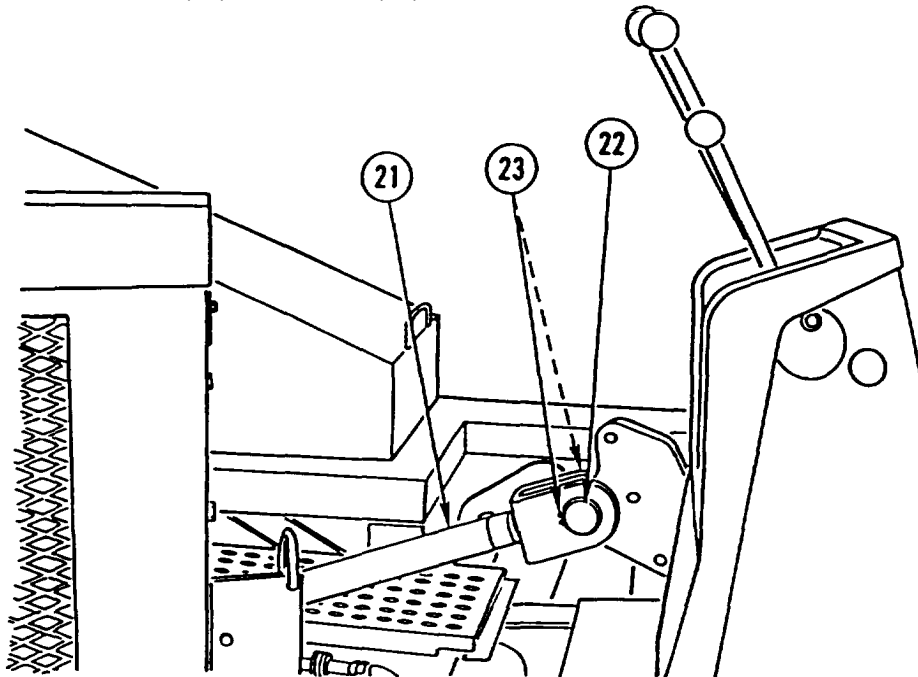

9. CONNECT tilt CYLINDER (21) and install pin (22) and two retaining rings (23).

NOTE

Follow-on Maintenance:

Install backhoe seat (page 4-444).

BACKHOE SWING CONTROL PEDAL ADJUSTMENT

This task covers: Adjustment

INITIAL SETUP

Applicable Configuration:

SEE

Tools and Special Equipment:

Tool Kit, SC 5180-90-CL-N26

Materials/Parts:

Pin, Cotter

Equipment Condition:

Reference

Page 2-22

Page 4-404

Condition

Backhoe in Three-Point Stance

Backhoe Control Tower Removed

ADJUSTMENT

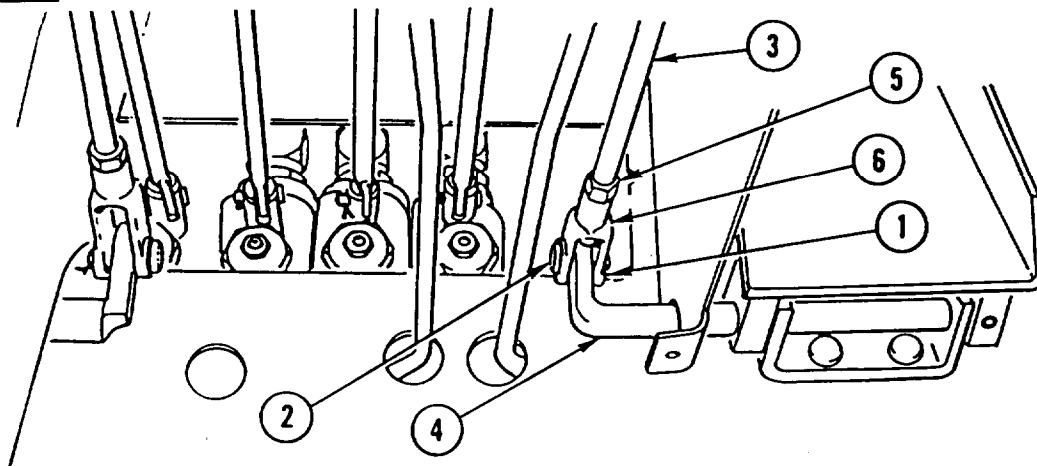

NOTE

- Adjust either or both control pedals.
- Make sure control valve spool is in neutral position.
- Make sure control pedals are even and have enough movement to fully actuate valve.

1. Remove cotter pin (1) and pin (2) from control rod (3) and shaft (4). Discard cotter pin.
2. Back off nut (5) and turn clevis (6), as needed, for proper length.
3. Install pin (2) through control rod (3) and shaft (4).
4. Perform steps 1 thru 3, as needed, for proper adjustment.
5. When adjustment is complete, tighten nut (5) and install new cotter pin (1).

NOTE

Follow-on Maintenance:
install backhoe control tower (page 4-404).

BACKHOE CONTROL LEVER REPLACEMENT

This task covers: a. Removal b. Installation

INITIAL SETUP

Applicable Configuration:

SEE

Tools and Special Equipment:

Shop Equipment, SC 4910-95-CL-A74
 Tool Kit, SC 5180-90-CL-N26

Materials/Parts:

Screw, Self-Tapping (3)
 Pin, Cotter (16)
 Washer, Lock

Personnel Required: (2)

Equipment Condition:

Reference

Page 2-22

Page 4-444

Condition Description

Backhoe in Three-Point
 Stance

Backhoe Seat Removed

REMOVAL

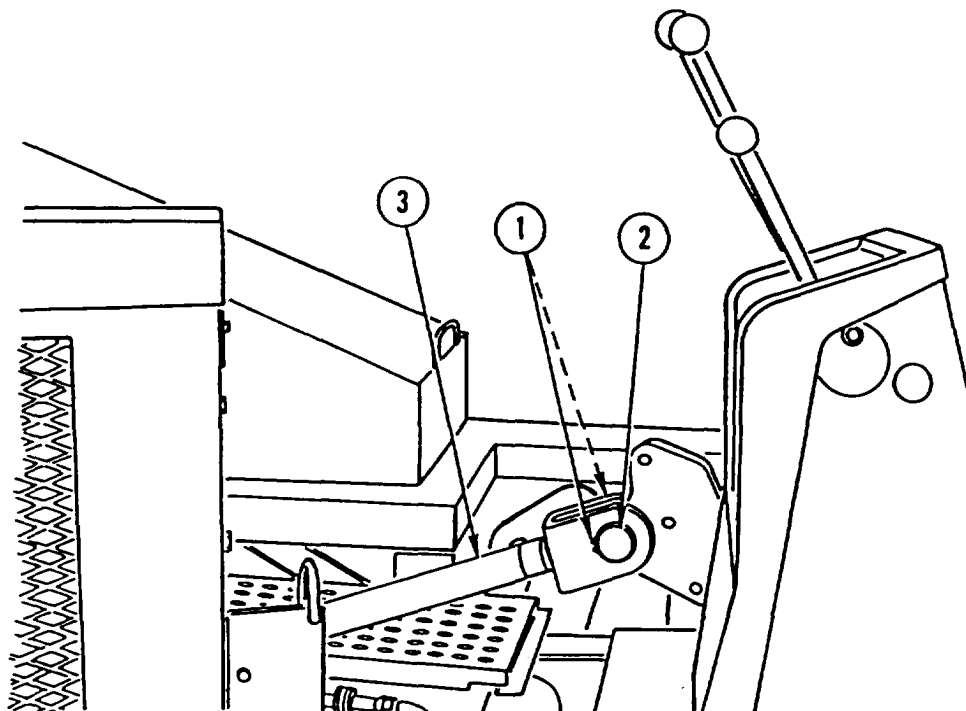

1. REMOVE two retaining rings (1) and PIN (2) and DISCONNECT tilt CYLINDER (3). SECURE tilt CYLINDER out of the way.

BACKHOE CONTROL LEVER REPLACEMENT (CONT)

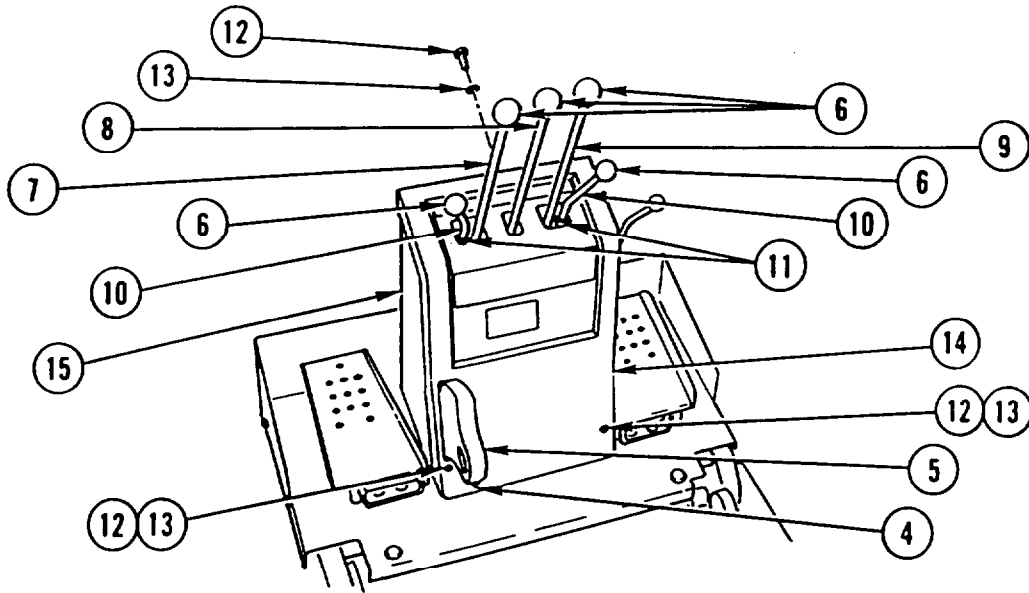

2. REMOVE grease FITTING (4) from bracket (5).
3. REMOVE five KNOBS (6) from three control handles (7, 8, and 9) and two rods (10).
4. LOOSEN two NUTS (11) and ROTATE two RODS (10) in toward center.
5. REMOVE three self-tapping screws (12), three washers (13), and COVER (14) from control tower (15). DISCARD self-tapping SCREWS.

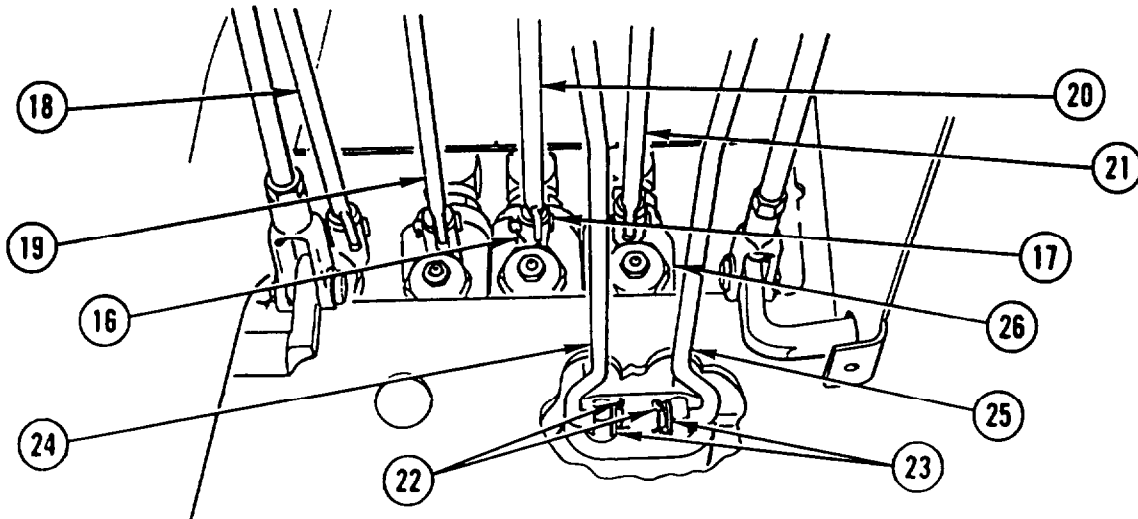

6. REMOVE four cotter pins (16) and four PINS (17) from four control rods (18, 19, 20, and 21). DISCARD cotter PINS.
7. REMOVE two cotter pins (22) and two WASHERS (23) from two control rods (24 and 25). DISCARD cotter PINS.
8. DISCONNECT two control RODS (24 and 25) from backhoe control valve (26).

BACKHOE CONTROL LEVER REPLACEMENT (CONT)

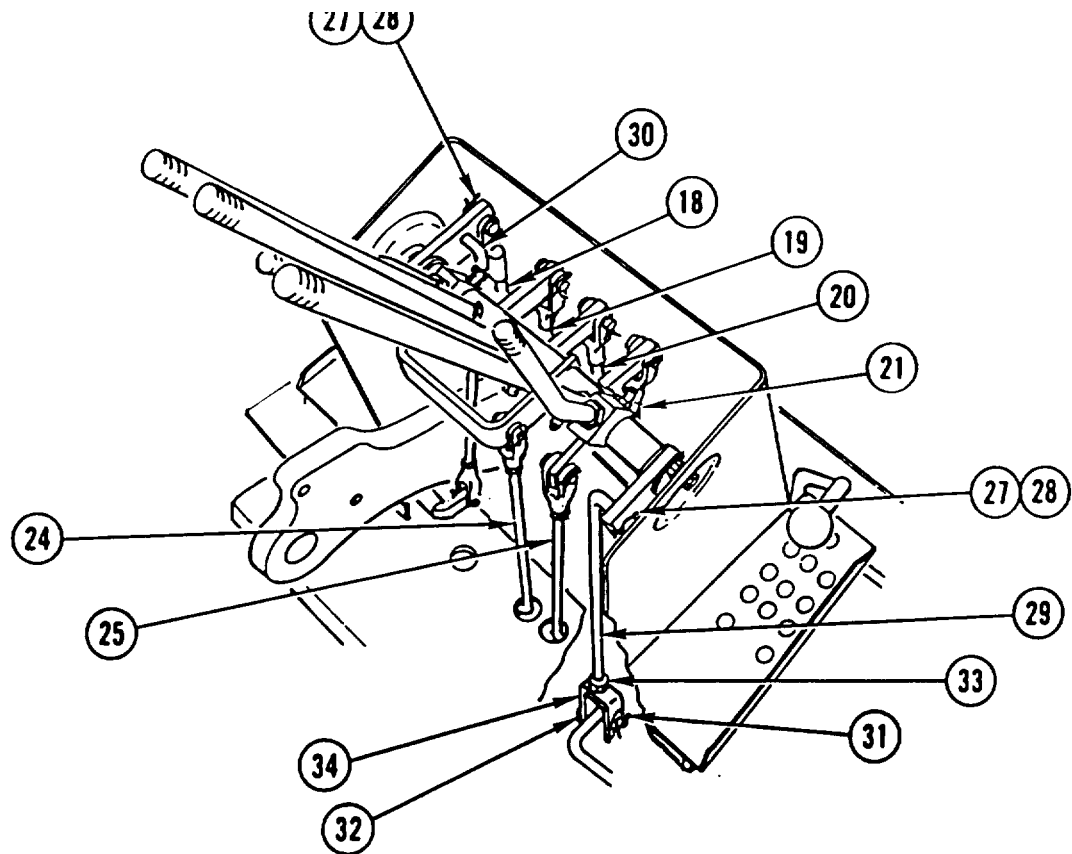

9. REMOVE two cotter pins (27) and two WASHERS (28) from two control rods (29 and 30). DISCARD cotter PINS.

NOTE

Tag all control rods prior to removal to aid in installation.

10. REMOVE cotter pin (31), pin (32), and control ROD (29). DISCARD cotter PIN.
11. LOOSEN NUT (33) and REMOVE CLEVIS (34) and nut (33) from control rod (29).
12. REPEAT STEPS 10 and 11 for seven remaining control rods (18, 19, 20, 21, 24, 25, and 30).

BACKHOE CONTROL LEVER REPLACEMENT (CONT)

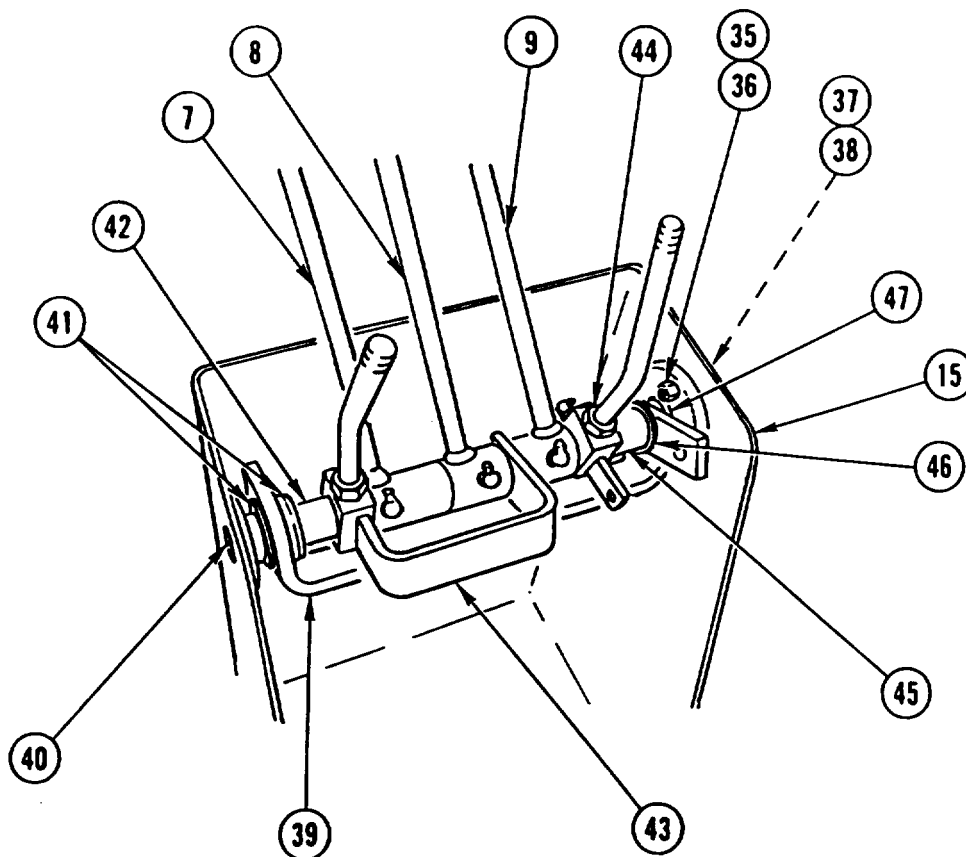

13. REMOVE nut (35) lock washer (36), SCREW (37), and washer (38) from control tower (15). DISCARD LockWASHER:

NOTE

- While performing step 14, it may be necessary to use two personnel.
- Washers are used as spacers. Number of washers may vary. Note quantity of washers removed.
- Tag all parts prior to removal to aid in installation.

14. SUPPORT BRACKET (39) and PULL SHAFT (40) OUT SLOWLY while removing washer(s) (41), spacer (42), two control handles (7 and 8), lever assembly (43), control handle (9), lever assembly (44), spacer (45), washer (46), bracket (39), and washer (47) from control tower (15).

BACKHOE CONTROL LEVER REPLACEMENT (CONT)

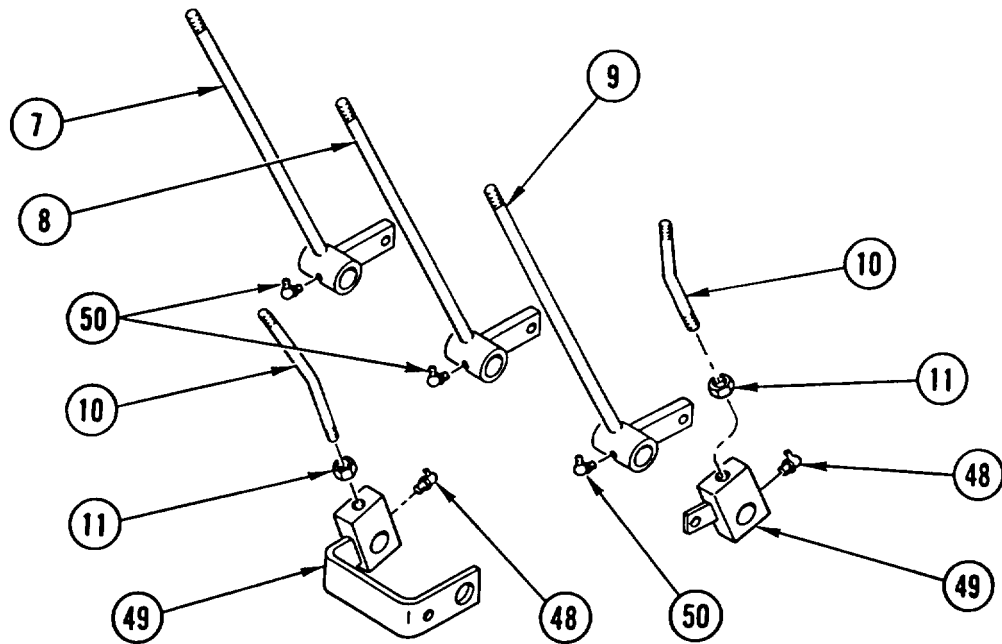

15. REMOVE two RODS (10), two nuts (1 1), and two lubrication fittings (48) from two lever brackets (49).
16. REMOVE three lubrication FITTINGS (50) from three control handles (7, 8, and 9).

INSTALLATION

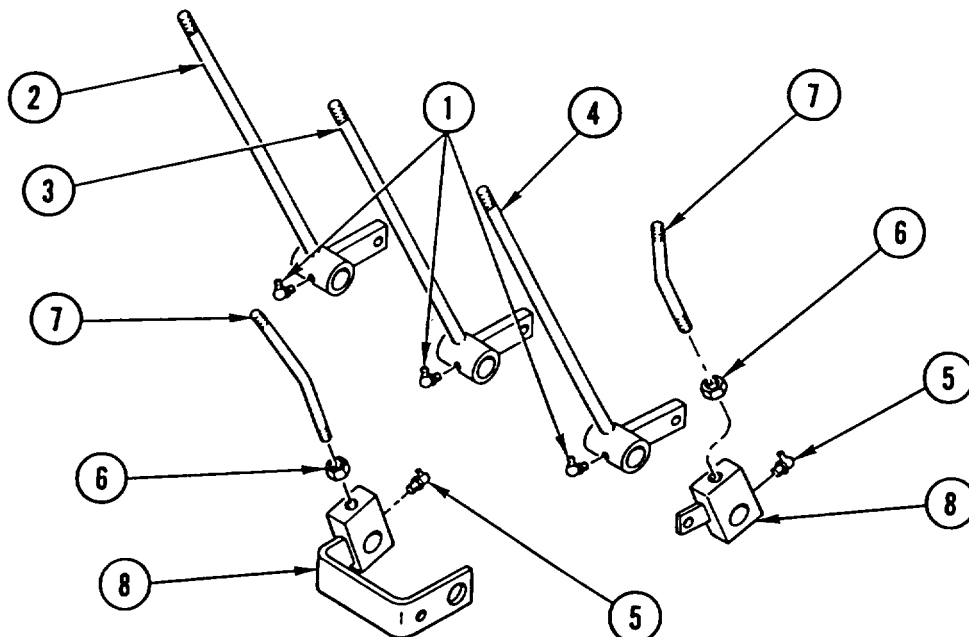

1. INSTALL three lubrication FITTINGS (1) in three control handles (2, 3, and 4).
2. INSTALL two lubrication fittings (5), two nuts (6), and two RODS (7) in two lever brackets (8).

BACKHOE CONTROL LEVER REPLACEMENT (CONT)

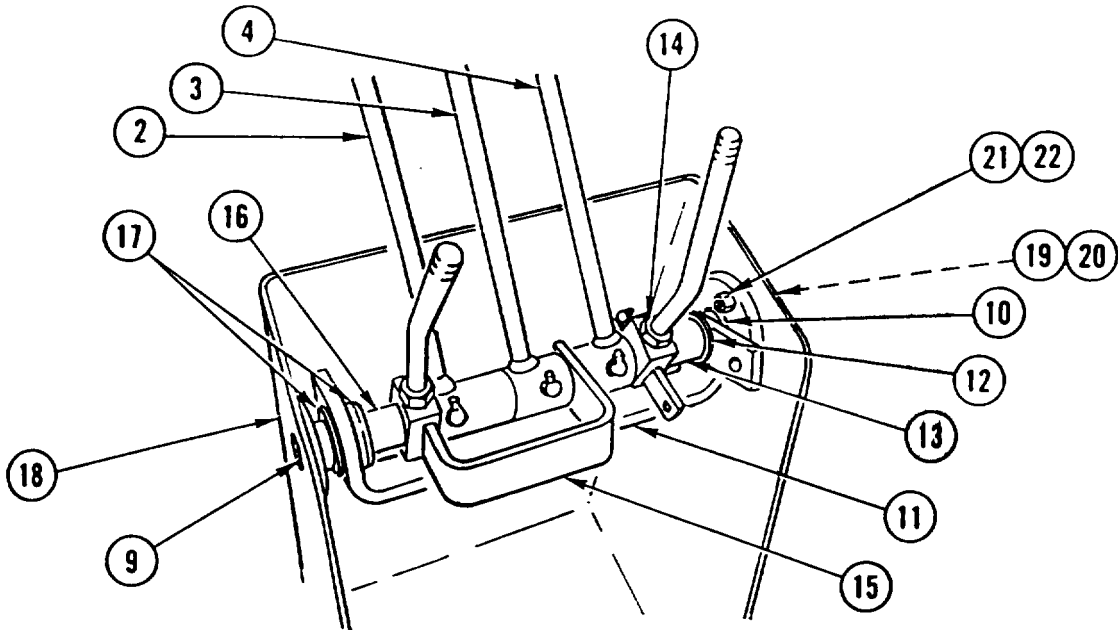

NOTE

- While performing step 3, it may be necessary to use two personnel.
- Washers are used as spacers. Install number of washers noted during removal.

3. INSERT SHAFT (9) while installing washer (10), bracket (11), washer (12), spacer (13), lever assembly (14), control handle (4), lever assembly (15), two control handles (2 and 3), spacer (16), and washer(s) (17) in control tower (18).
4. INSTALL washer (19), SCREW (20), new lock washer (21), and nut (22) in control tower (18).

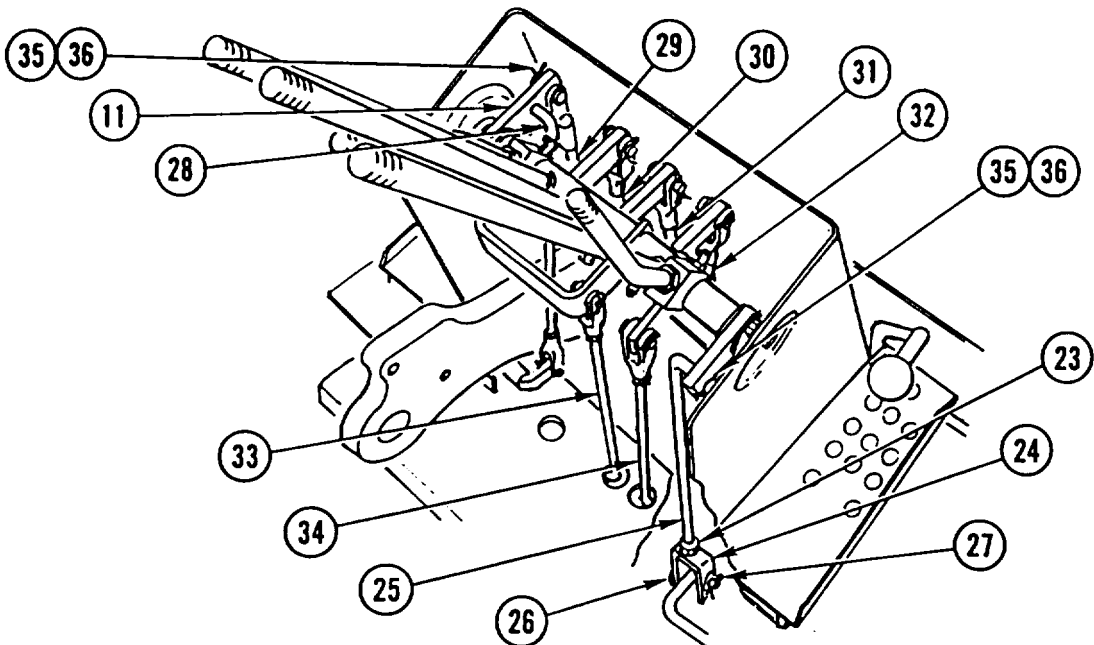

BACKHOE CONTROL LEVER REPLACEMENT (CONT)

5. INSTALL nut (23) and CLEVIS (24) on control rod (25).
6. INSTALL control ROD (25), pin (26), and new cotter pin (27).
7. REPEAT STEPS 5 and 6 for seven remaining control rods (28, 29, 30, 31, 32, 33, and 34).
8. INSTALL two control RODS (25 and 28), two washers (35), and two new rotter pins (36) in bracket (11).

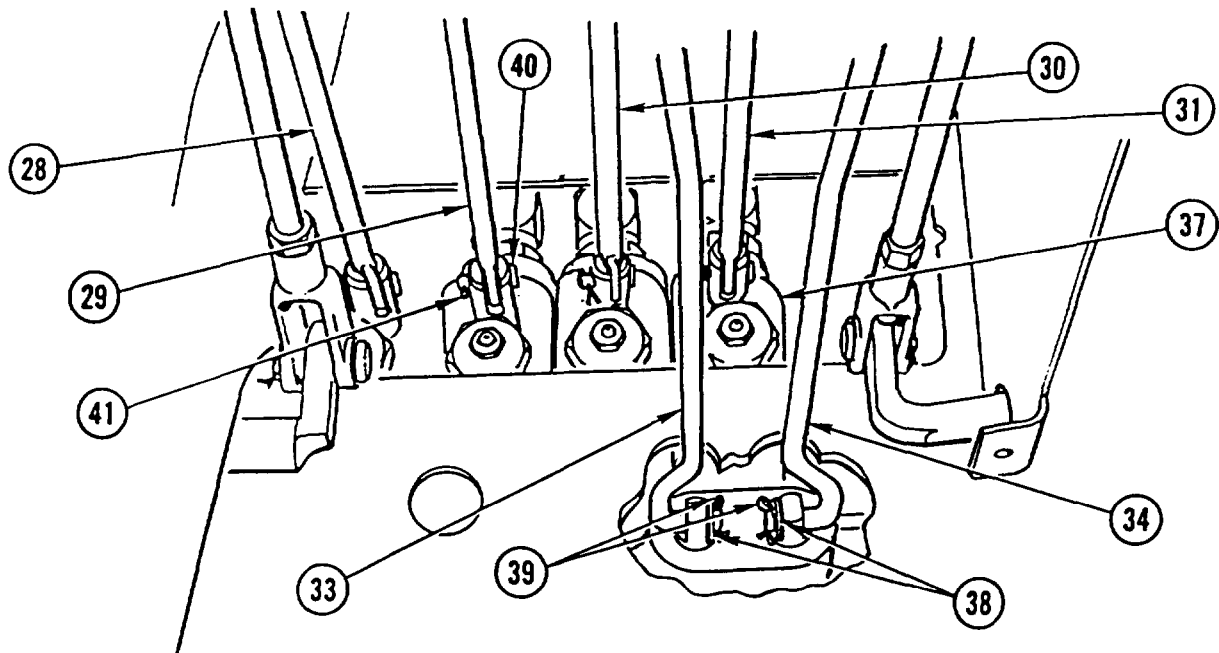

9. CONNECT two control RODS (33 and 34) to backhoe control valve (37).
10. INSTALL two WASHERS (38) and two new cotter pins (39) in two control rods (33 and 34).
11. INSTALL four PINS (40) and four new cotter pins (41) in four control rods (28, 29, 30, and 31) and backhoe control valve (37).

BACKHOE CONTROL LEVER REPLACEMENT (CONT)

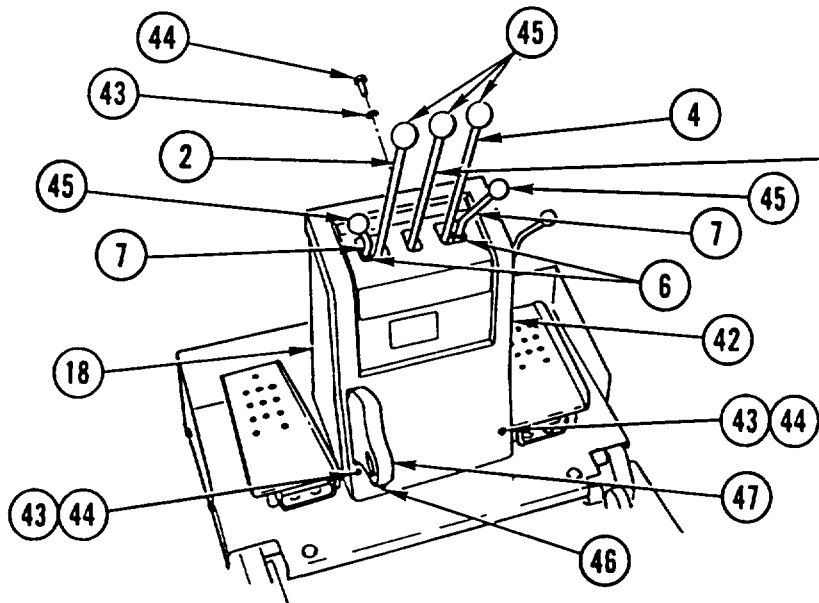

NOTE

If needed, adjust control rods at this time (page 4-531).

- 12. INSTALL COVER (42), three washers (43), and three new self-tapping screws (44) in control tower (18).
- 13. ROTATE two RODS (7) outward from center and TIGHTEN two NUTS (6).
- 14. INSTALL five KNOBS (45) on three control handles (2, 3, and 4) and two rods (7).
- 15. INSTALL grease FITTING (46) in bracket (47).

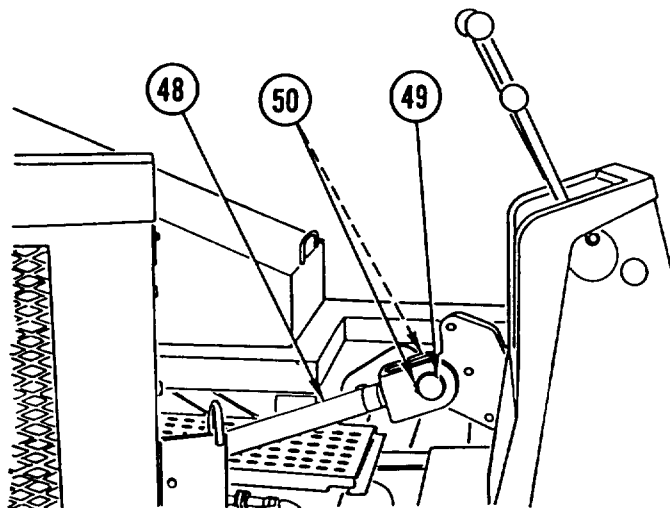

- 16. CONNECT tilt CYLINDER (48) and INSTALL PIN (49) and two retaining rings (50).

NOTE

Follow-on Maintenance:
Install backhoe seat (page 4-444).

BACKHOE CONTROL ROD ADJUSTMENT

This task covers: Adjustment

INITIAL SETUP

Applicable Configuration:

SEE

Tools and Special Equipment:

Shop Equipment, SC 491 O-95 -CL-A74
Toot Kit, SC 5180-90-CL-N26

Materials/Parts:

Pin, Cotter

Equipment Condition:

Reference

Page 2-22

Page 4-404

Condition Description

Backhoe in Three-Point Stance

Backhoe Control Tower Removed

ADJUSTMENT

NOTE

- Procedure is the same for all control rods.
- Make sure control valve spool is in neutral position.
- Make sure control levers are even with each other and centered in opening of cover.

1. Remove cotter pin (1) and pin (2) from control rod (3) and control lever (4). Discard cotter pin.
2. Back off nut (5) and turn clevis (6), as needed, for proper length.
3. Temporarily install pin (2) through control rod (3) and control lever (4).
4. Temporarily install cover (7) to check for proper position in opening.
5. Remove cover (7) and perform steps 1 thru 4, as needed, for proper adjustment.
6. When adjustment is complete, remove cover (7), tighten nut (5), and install new cotter pin (1).

NOTE

Follow-on Maintenance:
Install backhoe control tower (page 4-404).

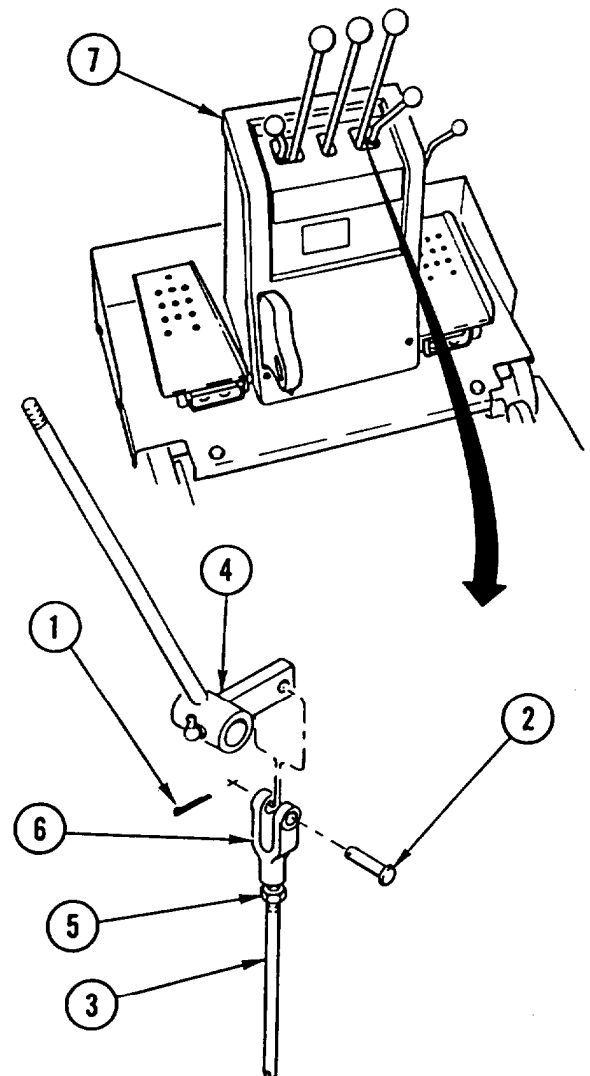

FRONT LOADER/FORKLIFT CONTROL VALVE CONTROLS REPLACEMENT AND ADJUSTMENT

This task covers: a. Removal b. Installation c. Adjustment

INITIAL SETUP

Tools and Special Equipment:

Tool Kit, SC 5180-90-CL-N26

Materials/Parts:

Pin, Cotter (2)

Personnel Required: (2)

Equipment Condition:

Reference	Condition Description
Page 4-390 or 4-391	Spare Tire and Mount Removed (SEE or HMMH)

General Safety Instructions:

WARNING

Do not connect or disconnect any electrical connector unless vehicle MASTER disconnect switch is OFF. To do so could result in injury to personnel.

REMOVAL

NOTE

Procedure is the same for both vehicles except as noted.

1. REMOVE two hitch pin clips (1) and two PINS (2) and DISCONNECT two CLEVISES (3).

NOTE

Perform step 2 on HMMH only.

2. DISCONNECT CABLE (4) from cable (5).
3. REMOVE two BOLTS (6) from lever bracket (7).
4. REMOVE three nuts (8), three capscrews (9), three washers (10), seal assembly plate (11), and front loader/forklift control LEVER assembly (12).
5. REMOVE two cotter pins (13) and two PINS (14) and DISCONNECT two CLEVISES (15). DISCARD cotter PINS.
6. REMOVE ROD (16) from boom handle block (17).

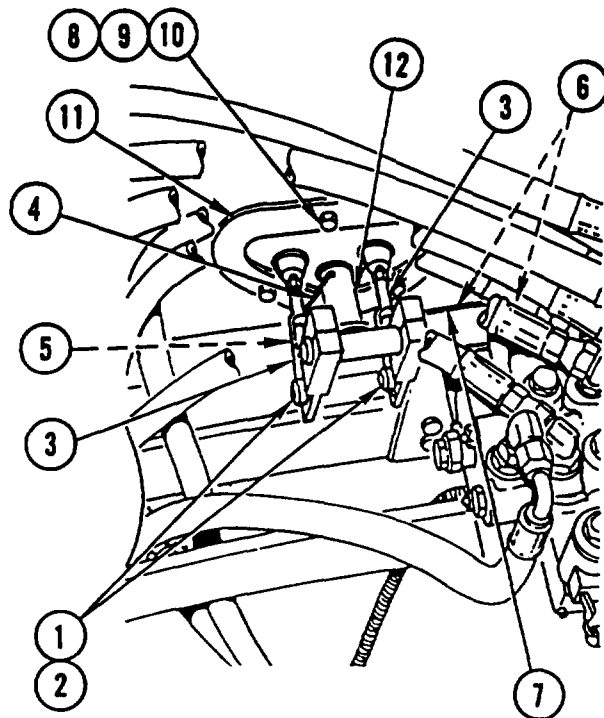

**FRONT LOADER/FORKLIFT CONTROL VALVE CONTROLS
REPLACEMENT AND ADJUSTMENT (CONT)**

7. REMOVE capscrew (18) and boom handle BLOCK (17) from shouldered shaft (19).
8. REMOVE capscrew (20) and remote control LEVER (21) from shouldered shaft (19).
9. REMOVE ROD (22) from manual control block (23).
10. REMOVE capscrew (24) and manual control BLOCK (23) from manual control lever (25).
11. REMOVE retaining ring (26), manual control LEVER (25), and shouldered shaft (19) from lever bracket (7).

NOTE

Perform steps 12 and 13 on HMMH only.

12. REMOVE setscrew (27) and push BUTTON (28) from knob (29).

NOTE

Tag cable wires prior to disconnecting to aid in connecting.

13. REMOVE two SCREWS (30), DISCONNECT CABLE (4) from push button (28), and REMOVE CABLE (4) from rod (22).
14. REMOVE KNOB (29) from rod (22).
15. REMOVE KNOB (31) from rod (16).

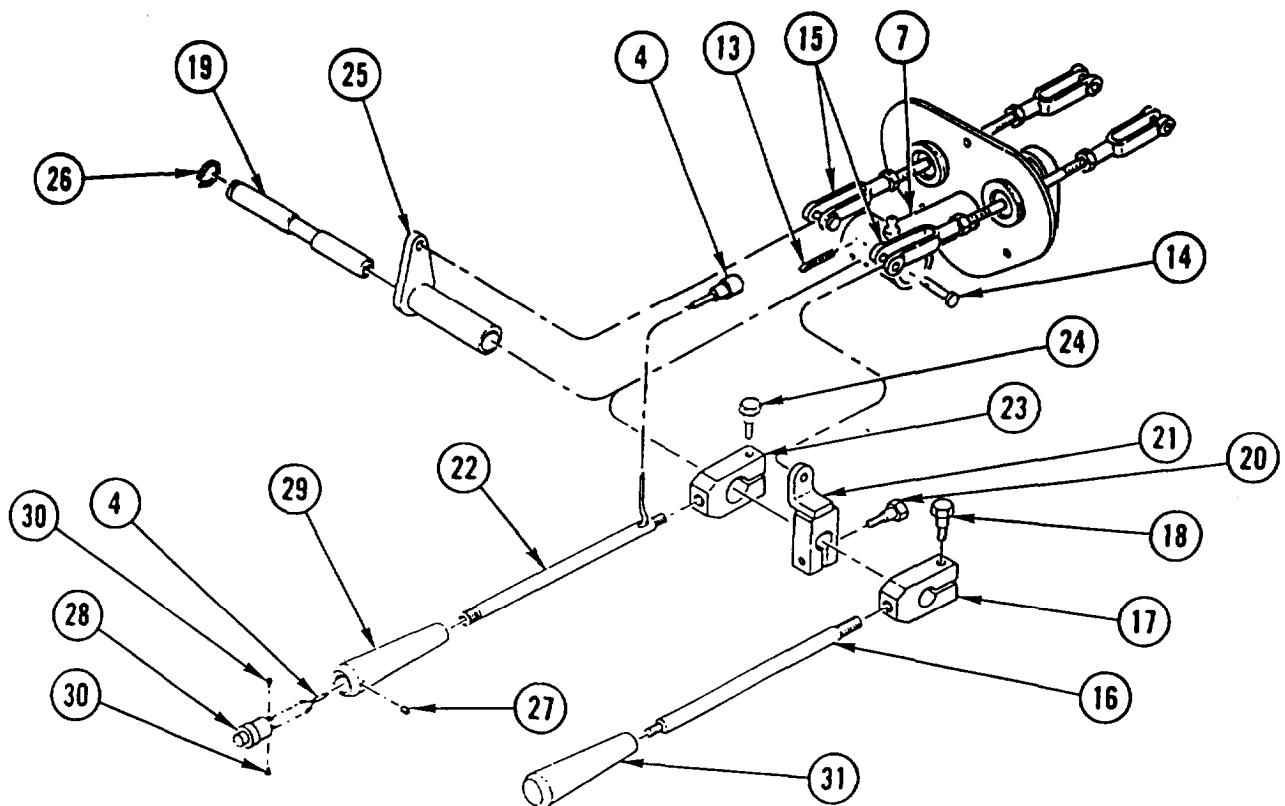

**FRONT LOADER/FORKLIFT CONTROL VALVE CONTROLS
REPLACEMENT AND ADJUSTMENT (CONT)**

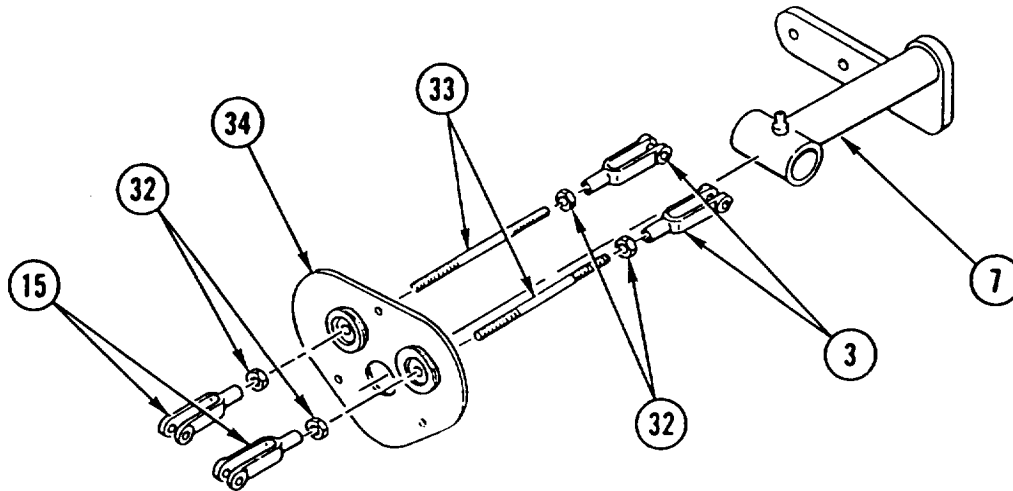

16. REMOVE four CLEVISSES (3 and 15) and four jam nuts (32) from two rods (33).
17. REMOVE two rods (33) and lever BRACKET (7) from seal assembly seal (34).

INSTALLATION

NOTE

Procedure is the same for both vehicles except as noted.

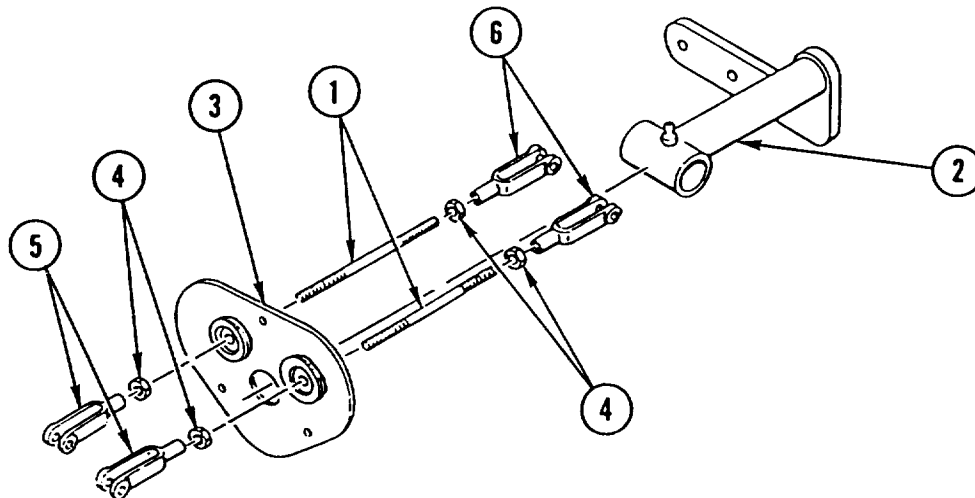

1. INSTALL two rods (1) and lever BRACKET (2) in seal assembly seal (3).
2. INSTALL four jam nuts (4) and four CLEVISSES (5 and 6) on two rods (1).
3. MEASURE DISTANCE between pin hole center lines of two clevises (5 and 6) on each rod (1). Distance should be 7 in. (178 mm). If distance is NOT CORRECT, ROTATE each CLEVIS IN or OUT, EQUALLY, until correct distance is achieved. TIGHTEN four jam NUTS (4) against four clevises (5 and 6).

**FRONT LOADER/FORKLIFT CONTROL VALVE CONTROLS
REPLACEMENT AND ADJUSTMENT (CONT)**

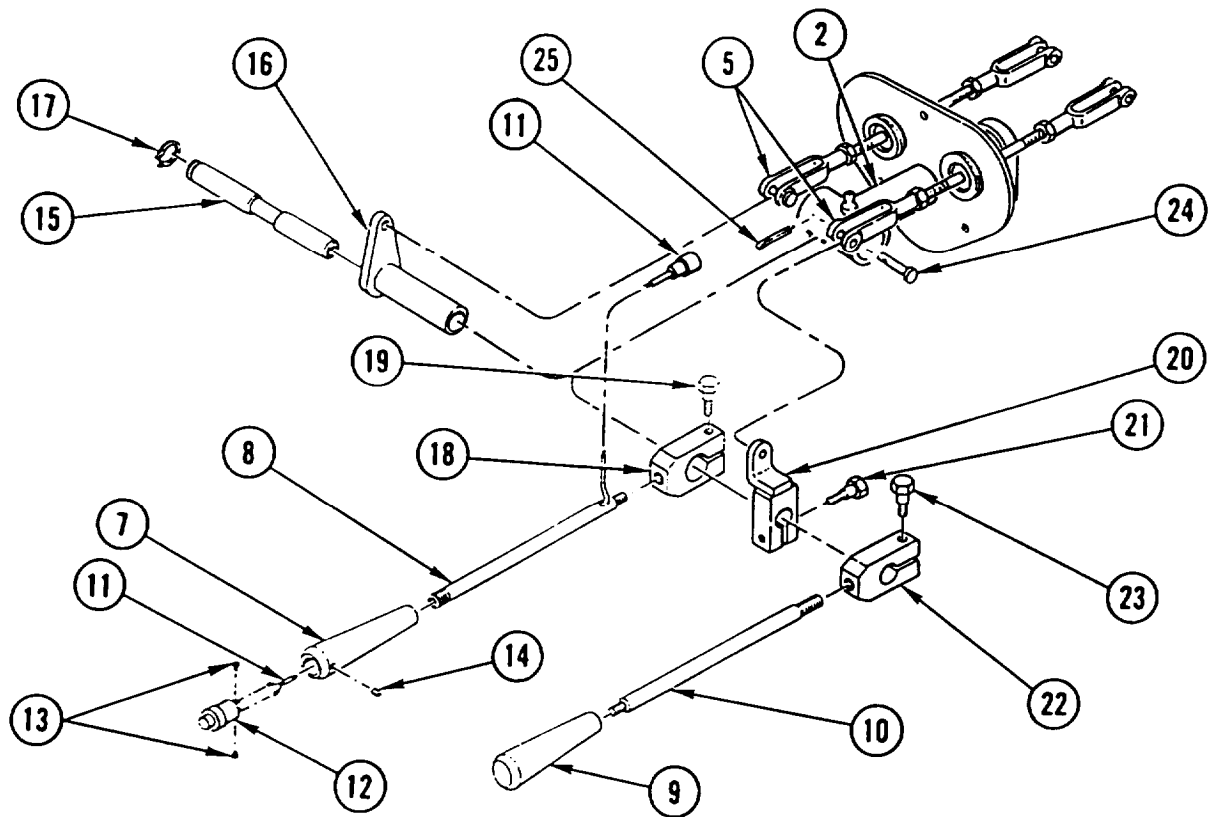

4. INSTALL KNOB (7) on rod (8).
5. INSTALL KNOB (9) on rod (10).

NOTE

Perform steps 6 and 7 on HMMH only.

6. INSTALL CABLE (11) in rod (8), CONNECT CABLE (11) to push button (12), and INSTALL two SCREWS (13).
7. INSTALL push BUTTON (12) and setscrew (14) in knob (7).
8. INSTALL shouldered shaft (15), manual control LEVER (16), and retaining ring (17) in lever bracket (2).
9. INSTALL manual control BLOCK (18) and capscrew (19) on manual control lever (16).
10. INSTALL ROD (8) in manual control block (18).
11. INSTALL remote control LEVER (20) and capscrew (21) on shouldered shaft (15).
12. INSTALL boom handle BLOCK (22) and capscrew (23) on shouldered shaft (15).
13. INSTALL ROD (10) in boom handle block (22).
14. INSTALL two PINS (24) and two new cotter pins (25) and CONNECT two CLEVISES (5).

FRONT LOADER/FORKLIFT CONTROL VALVE CONTROLS REPLACEMENT AND ADJUSTMENT (CONT)

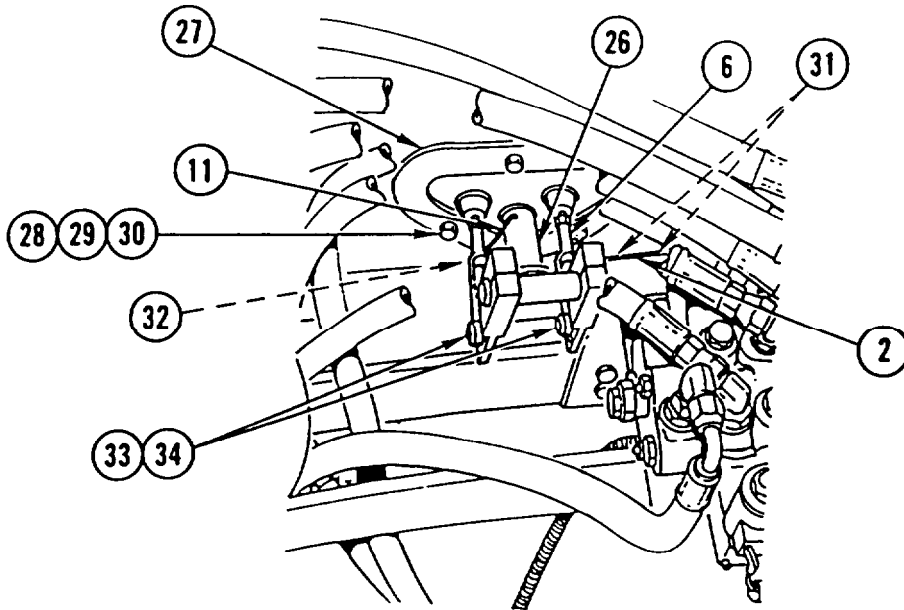

15. INSTALL front loader/forklift control LEVER assembly (26), seal assembly plate (27), three washers (28), three capscrews (29), and three nuts (30).
16. INSTALL two BOLTS (31) in lever bracket (2).

NOTE

Perform step 17 on HMMH only.

17. CONNECT CABLE (11) to cable (32).
18. INSTALL two PINS (33) and two hitch pin clips (34) and CONNECT two CLEVISES (6).

ADJUSTMENT

1. Loosen two screws (1) on two brackets (2).
2. Rotate two brackets (2) to achieve dimensions shown.
3. Tighten two screws (1) on two brackets (2).

NOTE

Follow-on Maintenance:
Install spare tire and mount (SEE or HMMH) (page 4-390 or 4-391).

**FRONT LOADER/FORKLIFT CONTROL VALVE CONTROLS
REPLACEMENT AND ADJUSTMENT (CONT)**

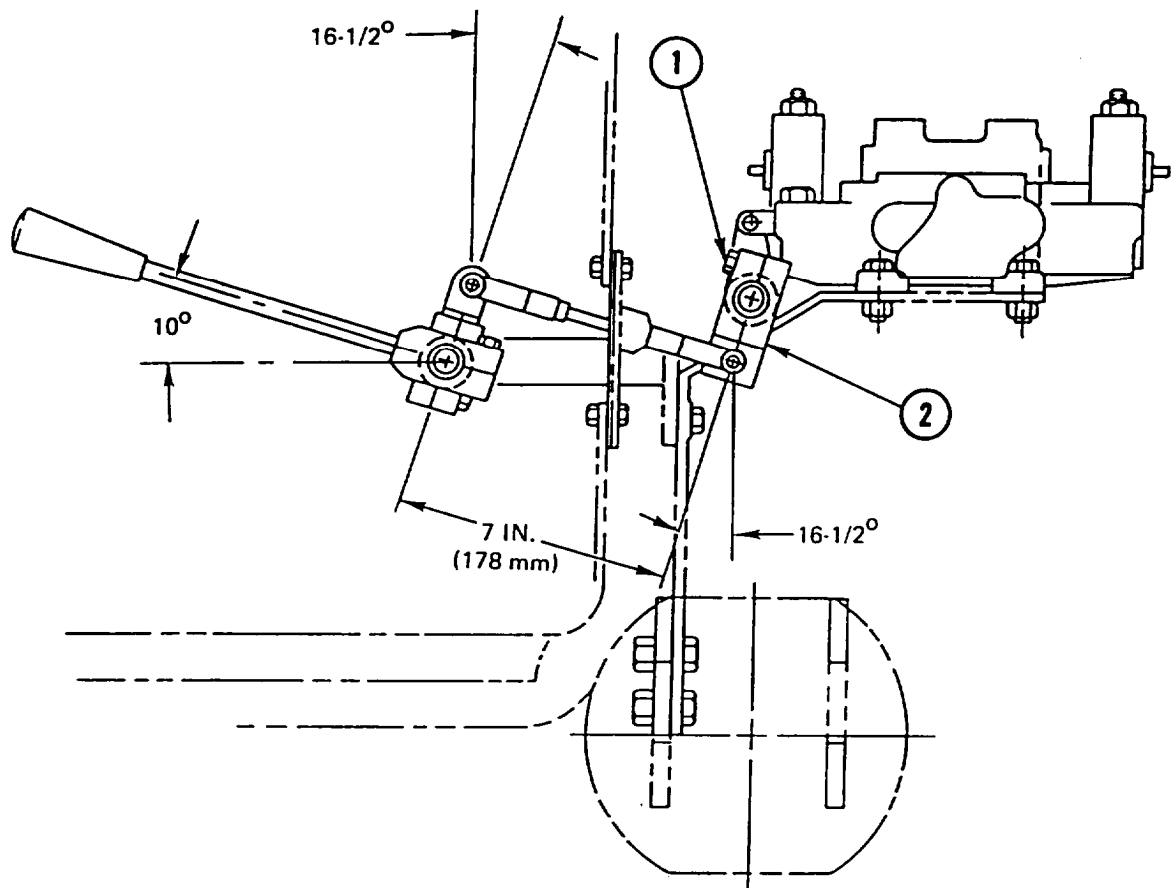

CRANE CONTROLS AND LINKAGES REPLACEMENT AND ADJUSTMENT

This task covers: a. Removal b. Installation c. Adjustment

INITIAL SETUP

Applicable Configuration:

HMMH

Tools and Special Equipment:

Tool Kit, SC 5180-90 -CL-N26

Materials/Parts:

Pin, Cotter (23)

Nut, Lock (2)

Nut, Lock

Equipment Condition:

Reference

Page 2-23

Condition Description

Crane in Three-Point Stance

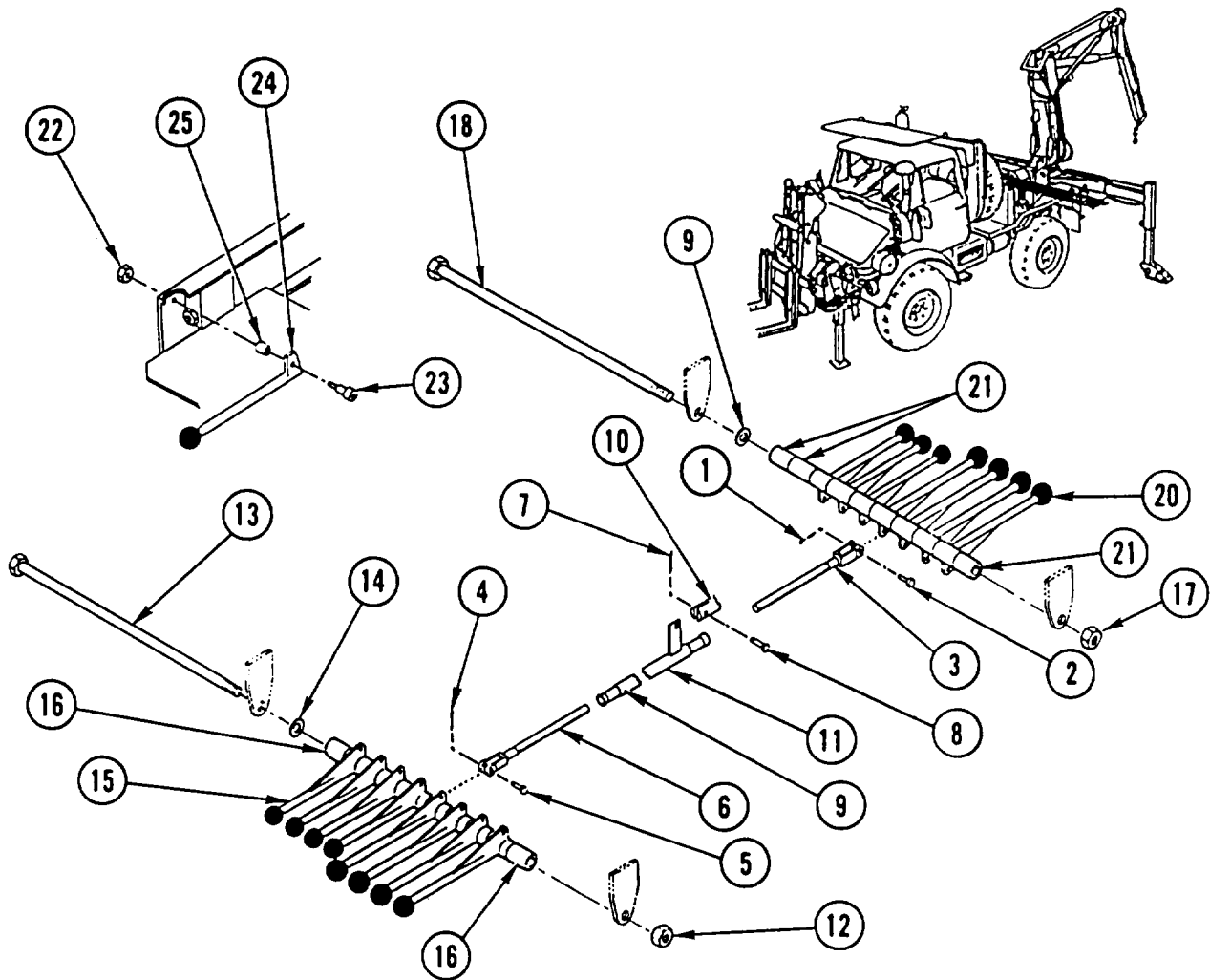

CRANE CONTROLS AND LINKAGES REPLACEMENT AND ADJUSTMENT (CONT)

REMOVAL

1. ON RIGHT SIDE, REMOVE seven cotter pins (1) and seven straight PINS (2) from seven connecting links (3). DISCARD cotter PINS.
2. ON LEFT SIDE, REMOVE eight cotter pins (4) and eight straight PINS (5) from eight connecting links (6). DISCARD cotter PINS.

NOTE

Tag control rod assemblies and connecting links prior to removal to aid in installation.

3. REMOVE eight cotter pins (7), eight straight pins (8), and eight control ROD assemblies (9) from valve bank (10). DISCARD cotter PINS.
4. REMOVE 15 connecting LINKS (3 and 6) from 8 interconnecting control rods (11).
5. ON LEFT SIDE, REMOVE lock nut (12), rod (13), washer (14), eight control HANDLES (15), and two spacers (16). DISCARD lock NUT.
6. ON RIGHT SIDE, REMOVE lock nut (17), rod (18), washer (19), seven control HANDLES (20), and three spacers (21). DISCARD lock NUT.
7. REMOVE lock nut (22), shoulder bolt (23), control HANDLE (24), and spacer (25). DISCARD lock NUT.

INSTALLATION

1. INSTALL spacer (25), control HANDLE (24), shoulder bolt (23), and new lock nut (22).
2. ON RIGHT SIDE, INSTALL rod (18), washer (19), two spacers (21), seven control HANDLES (20), spacer (21), and new lock nut (17).
3. ON LEFT SIDE, INSTALL rod (13), washer (14), spacer (16), eight control HANDLES (15), spacer (16), and new lock nut (12).
4. INSTALL 15 connecting LINKS (3 and 6) in 8 interconnecting control rods (11).
5. INSTALL eight control ROD assemblies (9), eight straight pins (8), and eight new cotter pins (7) on valve bank (10).

NOTE

During steps 6 and 7, it may be necessary to adjust the control rods. This should be done without moving the valve spool on the valve bank.

6. ON LEFT SIDE, INSTALL eight connecting LINKS (6) and eight straight pins (5).
7. ON RIGHT SIDE, INSTALL seven connecting LINKS (3) and seven straight pins (2).

CRANE CONTROLS AND LINKAGES REPLACEMENT AND ADJUSTMENT (CONT)

ADJUSTMENT

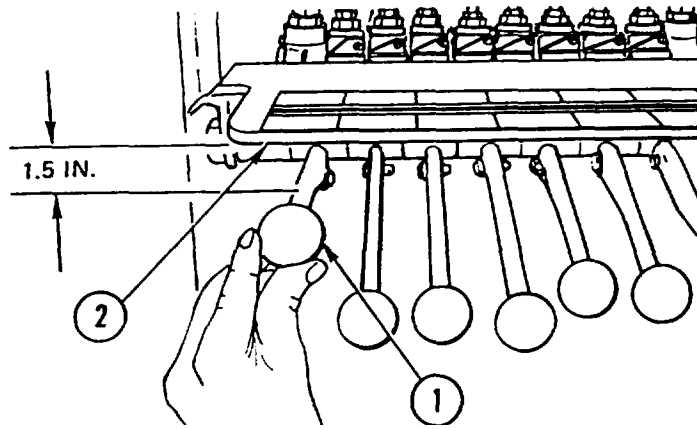

NOTE

Start adjustment at rear of crane and work toward vehicle.

1. Raise control handle (1) completely and measure distance between decal plate (2) and control handle (1). Distance should be 1.5 in. (36 mm).

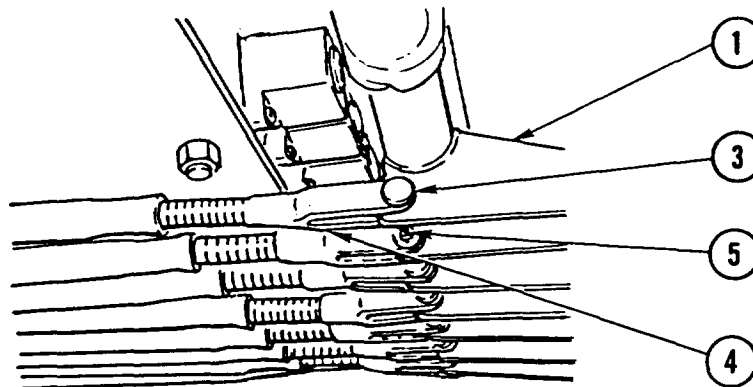

NOTE

Perform steps 2 thru 5 only if control handle is out of adjustment; if within normal range, go to step 6.

2. Remove straight pin (3) from control handle (1).
3. Rotate connecting link (4) left or right to raise or lower control handle (1) to obtain distance noted in step 1.
4. Install straight pin (3) in control handle (1).
5. Repeat steps 1 thru 4 until control handle is properly adjusted.
6. Install new cotter pin (5) in straight pin (3).
7. Repeat steps 1 thru 6 for remaining control handles.

FORKLIFT CROSSHEAD REPLACEMENT AND ADJUSTMENT

This task covers: a. Removal b. Installation c. Adjustment

INITIAL SETUP

Applicable Configuration:

HMMH

Tools and Special Equipment:

Tool Kit, SC 5180-90 -CL-N26

Materials/Parts:

Pin, Cotter (4)

Washer, Lock (2)

Caps and Plugs Appendix C, Item 7

Rags Appendix C, Item 32

References:

TM 5-2420-224-10

Equipment Condition:

Reference	Condition Description
TM 5-2420-224-10	Forklift Lowered to Ground
Page 2-23	Hydraulic Pressure Relieved

General Safety Instructions:

WARNING

- High pressure hydraulics [oil under 2450 psi (16,893 kPa)] operate this equipment. Never disconnect any hydraulic line or fitting without first dropping pressure to zero. A high pressure oil stream can pierce body and cause severe injury to personnel.
- Fuel and oil are slippery and can cause falls. To avoid injury, wipe up spilled fuel or oil with rags.

REMOVAL

CAUTION

Cap or plug all ports and ends of hoses and tubes to prevent contamination of hydraulic oil. Failure to do so may result in damage to equipment.

NOTE

Tag all lines prior to disconnecting to aid in connecting.

1. DISCONNECT two hydraulic HOSES (1). INSTALL CAPS or PLUGS.

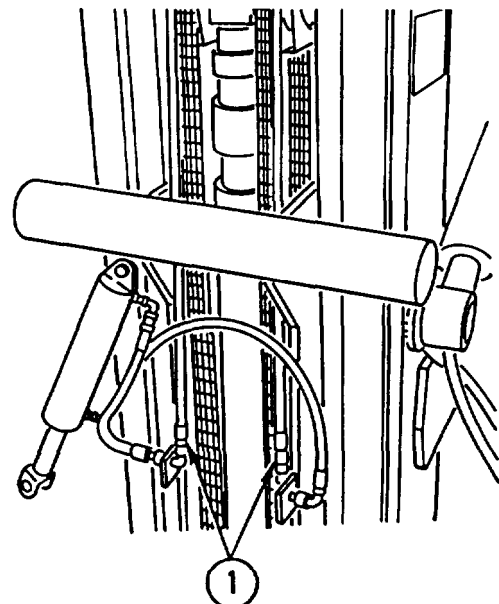

FORKLIFT CROSSHEAD REPLACEMENT AND ADJUSTMENT (CONT)

2. REMOVE four cotter pins (2) and two PINS (3) and DISCONNECT two carriage CHAINS (4). DISCARD cotter PINS.

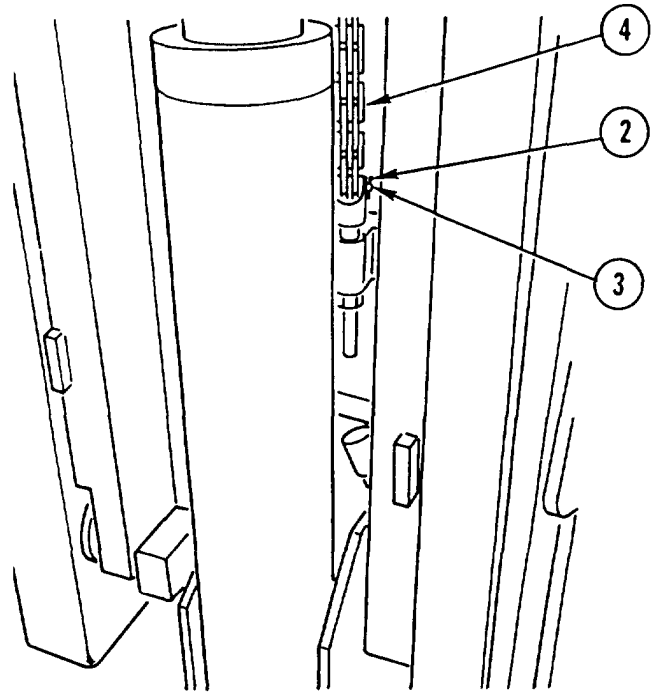

3. REMOVE two capscrews (5), two lock washers (6), two COVERS (7), and two bearings (8). DISCARD lock WASHERS.
4. REMOVE two hydraulic HOSES (1) from two rings (9). INSTALL CAPS or PLUGS.
5. REMOVE two carriage CHAINS (4) from two outer tires (10).
6. REMOVE two socket head capscrews (11) and ROLLER (12).
7. REMOVE retaining ring (13) and crosshead WELDMENT (14).

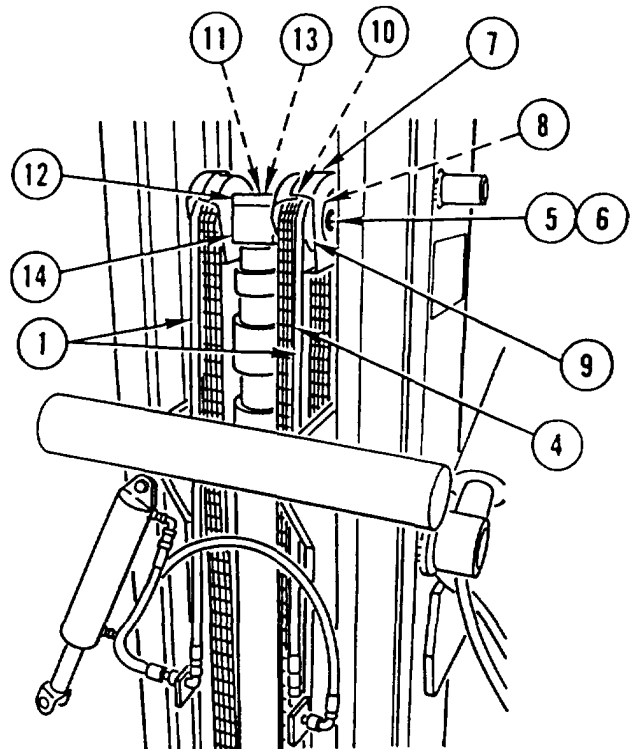

FORKLIFT CROSSHEAD REPLACEMENT AND ADJUSTMENT (CONT)

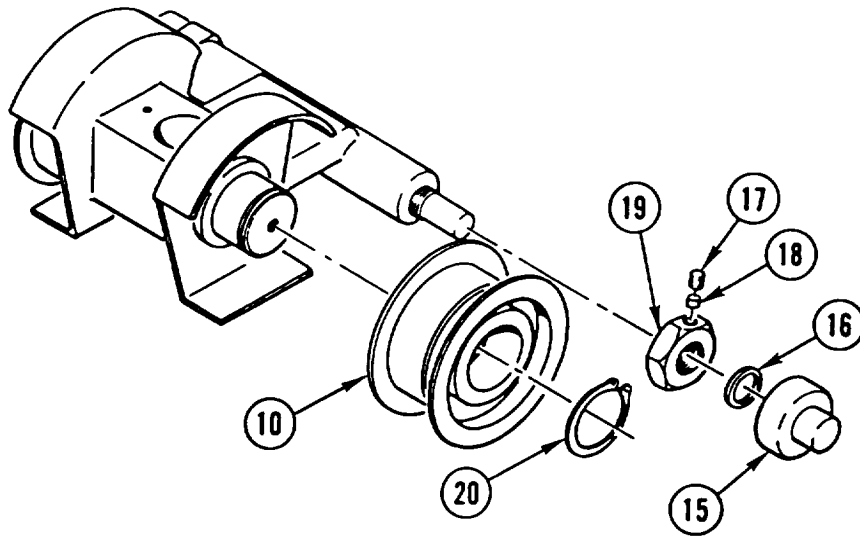

8. REMOVE two ROLLERS (15), two washers (16), two setscrews (17), two pellets (18), and two nuts (19).
9. REMOVE two retaining rings (20) and two outer TIRES (10)

INSTALLATION

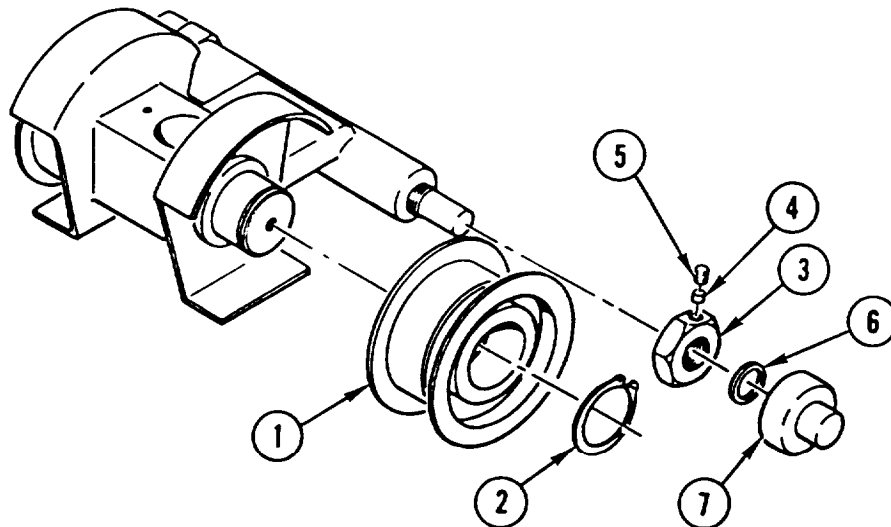

1. INSTALL two outer TIRES (1) and two retaining rings (2).
2. INSTALL two nuts (3), two pellets (4), two setscrews (5), two washers (6), and two ROLLERS (7).

FORKLIFT CROSSHEAD REPLACEMENT AND ADJUSTMENT (CONT)

3. INSTALL crosshead WELDMENT (8) and retaining ring (9).
4. INSTALL ROLLER (10) and two socket head capscrews (11).
5. INSTALL two carriage CHAINS (12) on two outer tires (1).
6. REMOVE CAPS or PLUGS. INSTALL two hydraulic HOSES (13) on two rings (14).
7. INSTALL two bearings (15), two COVERS (16), two new lock washers (17), and two capscrews (18).

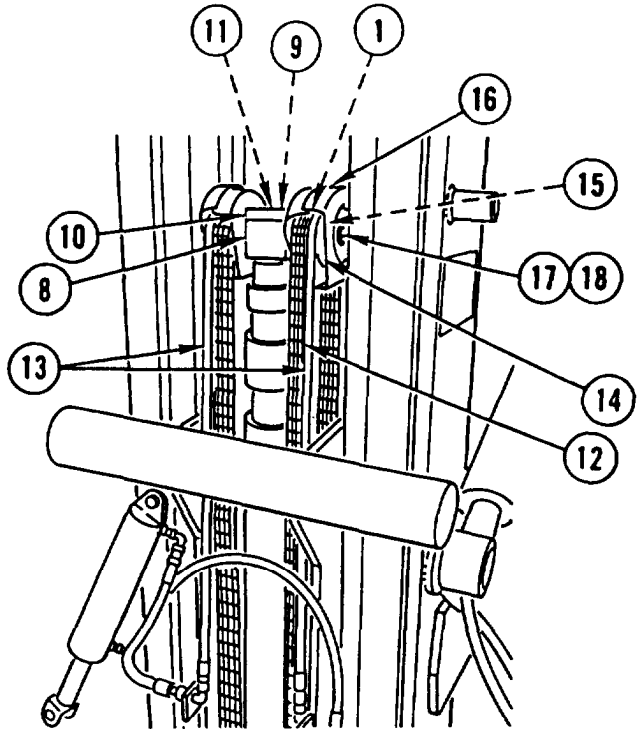

8. CONNECT two carriage CHAINS (12) and INSTALL two PINS (19) and four new cotter pins (20).

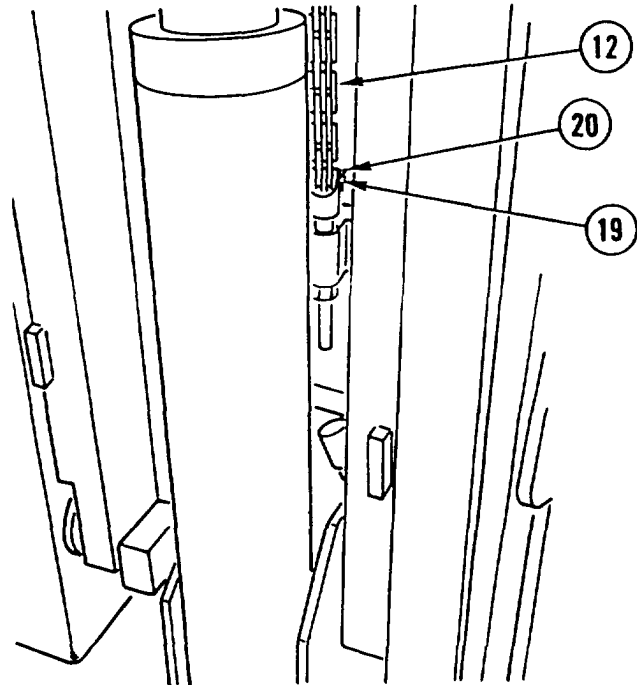

FORKLIFT CROSSHEAD REPLACEMENT AND ADJUSTMENT (CONT)

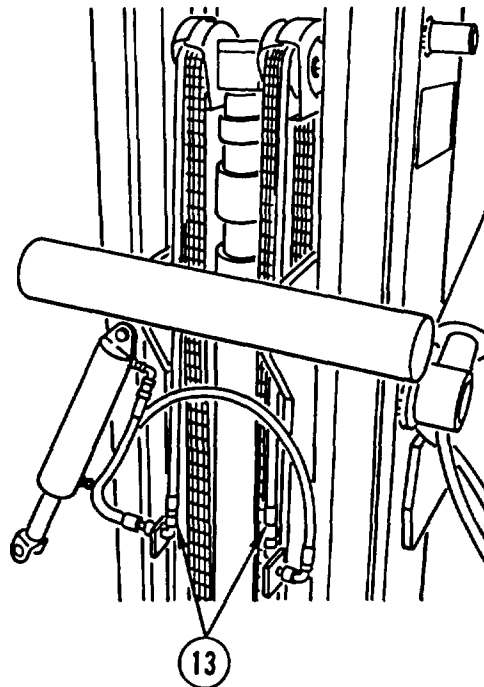

REMOVE CAPS or PLUGS. CONNECT two hydraulic HOSES (13).

ADJUSTMENT

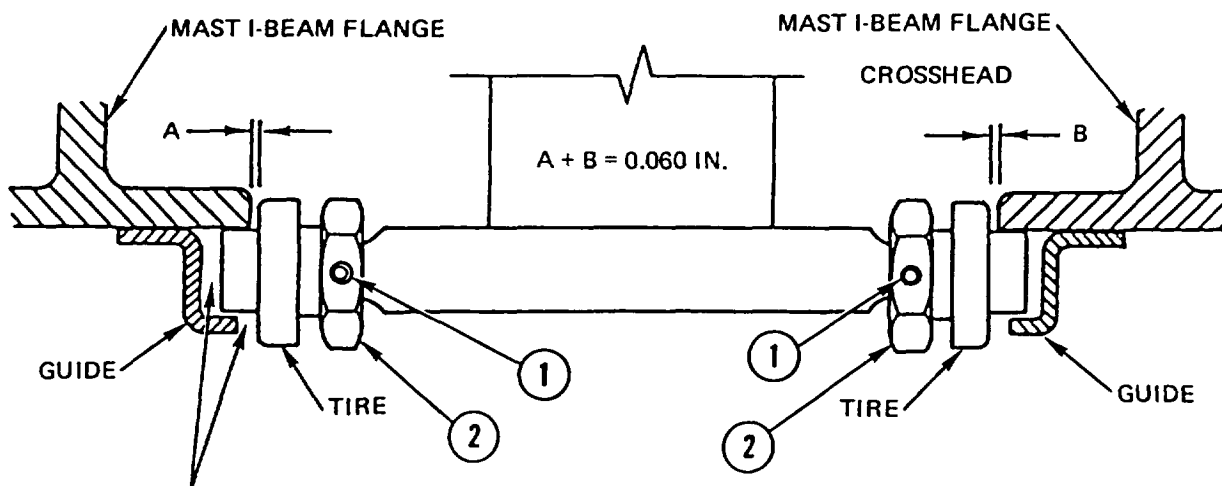

CAUTION: THE TIRE SHOULD NEVER TOUCH THE GUIDE AT THESE POINTS.

NOTE

Total clearance between tire shoulder and mast I-beam must be 0.060 in. (1.5 mm). If one tire is touching I-beam, which is acceptable, other tire should have 0.060 in. (1.5 mm) clearance.

1. Loosen one setscrew (1).
2. Turn nut (2) to attain proper clearance.
3. Tighten setscrew (1).

FORKLIFT REPLACEMENT

This task covers: a. Removal b. Installation

INITIAL SETUP

Applicable Configuration:

HMMH

Tools and Special Equipment:

Shop Equipment, SC 4910-95-CL-74
Tool kit, SC 5180-90 -CL-N26
Stand (2), P/N 41958070 18

Materials/Parts:

Washer, Lock (2)

Caps and Plugs Appendix C, Item 7

Rags Appendix C, Item 32

Personnel Required: (2)

References:

TM 5-2420-224-10

General Safety Instructions:

WARNING

- HMMH should not be operated with forklift removed, except in a maintenance facility. When maintenance is required and forklift is removed, never operate HMMH at speeds greater than 5 mph. Tractor stability and handling characteristics are greatly affected with forklift removed. This could cause loss of control and injury to personnel or damage to vehicle.
- High pressure hydraulics [oil under 2450 psi (26,893 kPa)] operate this equipment. Never disconnect any hydraulic line or fitting without first dropping pressure to zero. A high pressure oil stream can pierce body and cause severe injury to personnel.
- Do not connect or disconnect any electrical connector unless vehicle MASTER disconnect switch is OFF. To do so could result in injury to personnel.
- Fuel and oil are slippery and can cause falls. To avoid injury, wipe up spilled fuel or oil with rags.

FORKLIFT REPLACEMENT (CONT)

REMOVAL

1. PARK VEHICLE on firm, level ground and SET parking BRAKE.
2. REMOVE two fork retaining PLATES (1) and PLACE in STORAGE position (2).

WARNING

Make sure forklift forks are down and securely pinned. Failure to do so could result in serious injury to personnel.

3. SECURE two FORKS (3) with two lock pins (4) and POSITION FORKS (3) approximately 21 in. (53 cm) apart.
4. LOWER CARRIAGE (5) COMPLETELY with forks (3) parallel to ground.

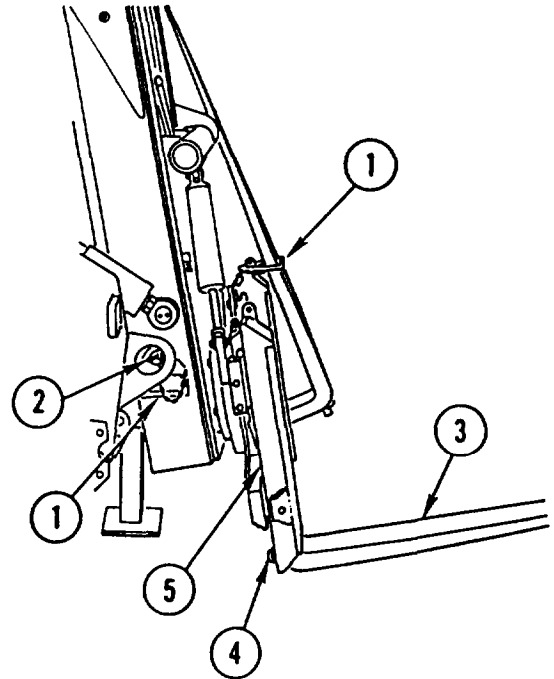

5. TURN mast lift cylinder hydraulic shutoff VALVE (6) to CLOSED position.

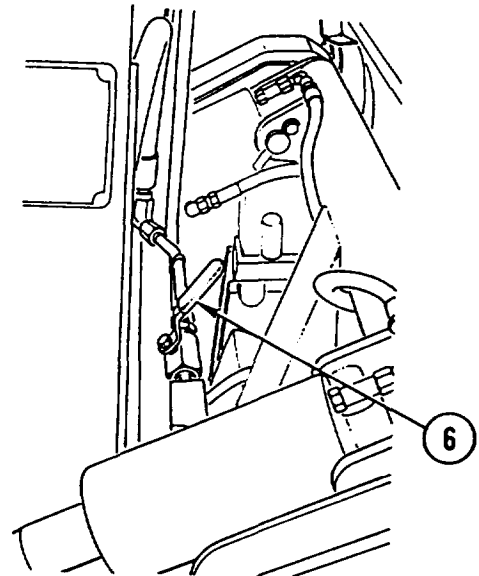

FORKLIFT REPLACEMENT (CONT)

6. TILT MAST (7) FORWARD until tips of forks (3) firmly contact ground and rear of forks (3) are approximately 4 in. (10 cm) off ground.

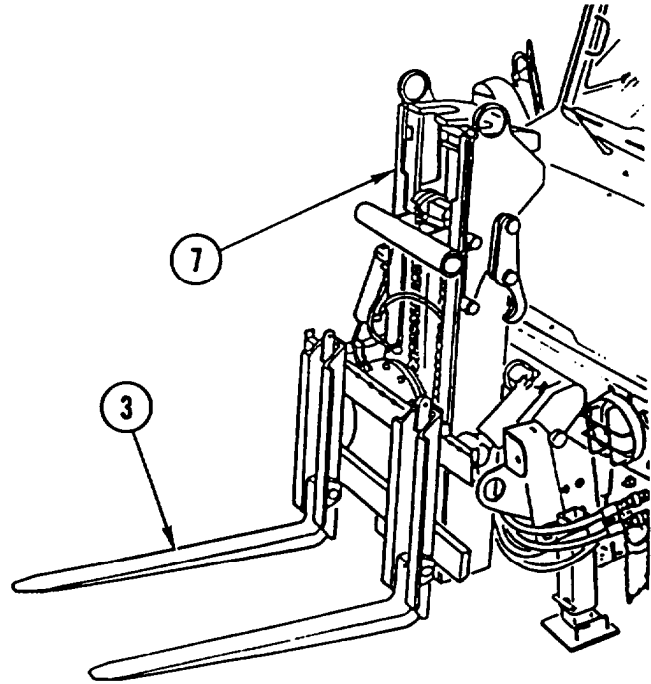

7. TURN tilt cylinder shutoff VALVE (8) to CLOSED position.
8. RELIEVE HYDRAULIC PRESSURE (page 2-23).
9. LOWER forklift STABILIZERS (9) to within approximately 4 in. (10 cm) of around and INSTALL PINS.

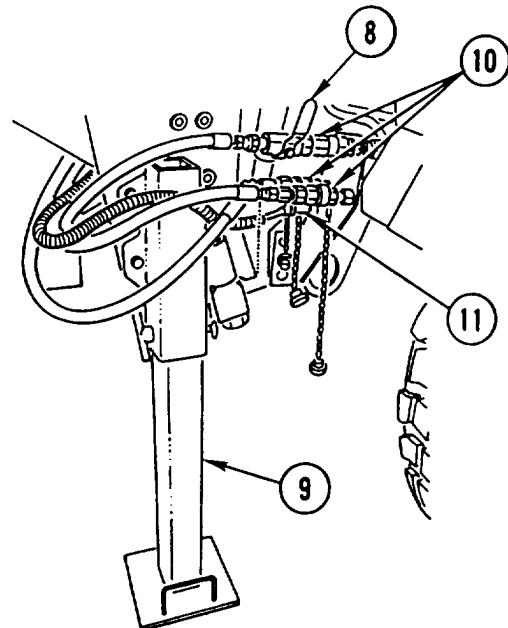

CAUTION

Cap or plug all ports and ends of hoses and tubes to prevent contamination of hydraulic oil. Failure to do so may result in damage to equipment.

NOTE

Tag lines prior to disconnecting to aid in connecting.

10. DISCONNECT three hydraulic HOSES (10). INSTALL CAPS or PLUGS.
11. DISCONNECT electrical CONNECTOR (11).

FORKLIFT REPLACEMENT (CONT)

12. INSTALL and PIN two STANDS on two jack fixtures (12) and lower STANDS to ground.

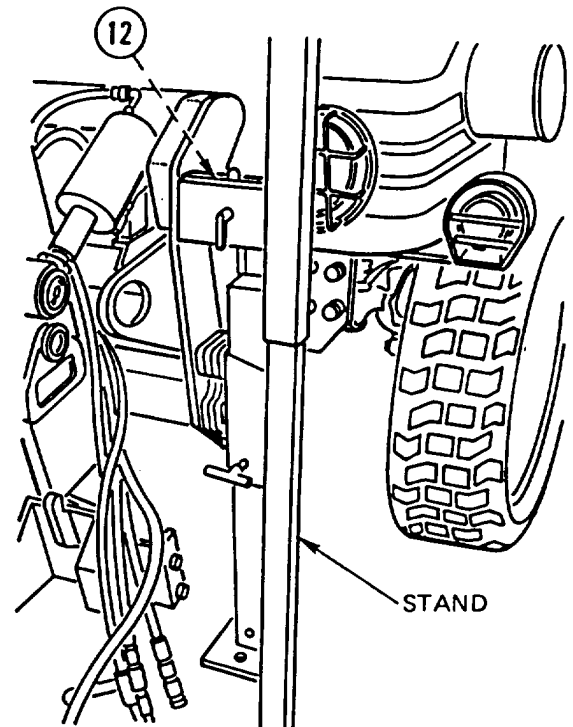

13. REMOVE two mounting SCREWS (13) and two lock washers (14).
14. RAISE STANDS simultaneously, LIFTING FORKLIFT assembly (15) 0.5 in. (13 mm) off frame saddle (16).

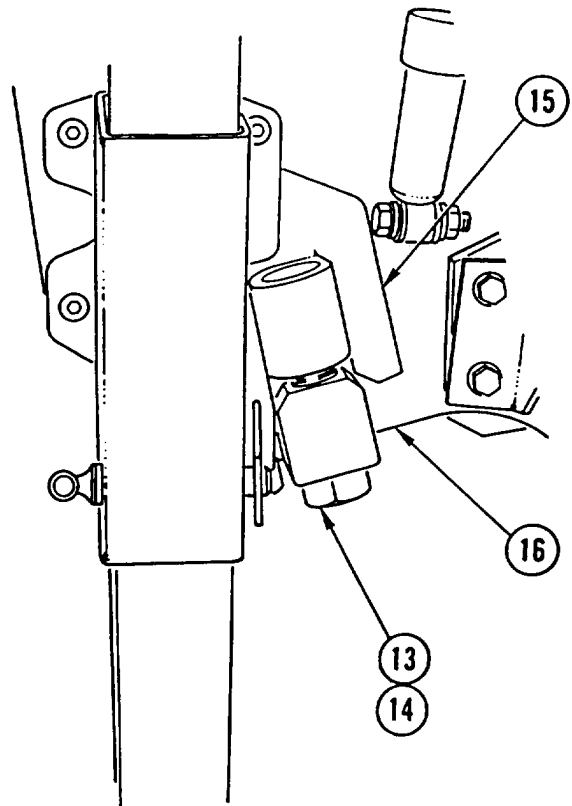

FORKLIFT REPLACEMENT (CONT)

WARNING

Tractor front wheels must be in line with forklift assembly prior to removal. If there is any contact between front wheels and forklift, reposition vehicle. Failure to do so could result in injury to personnel.

15. CAREFULLY BACK VEHICLE AWAY.
16. LOWER forklift STABILIZERS (9) to ground and INSTALL PINS.

NOTE

When lowering forklift assembly to ground, forklift stabilizers may rest on jack stand bases.

17. LOWER STANDS until forklift assembly (15) weight is on forklift stabilizers (9).

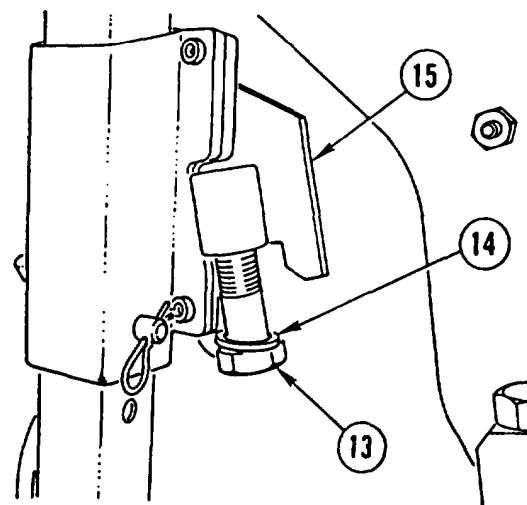
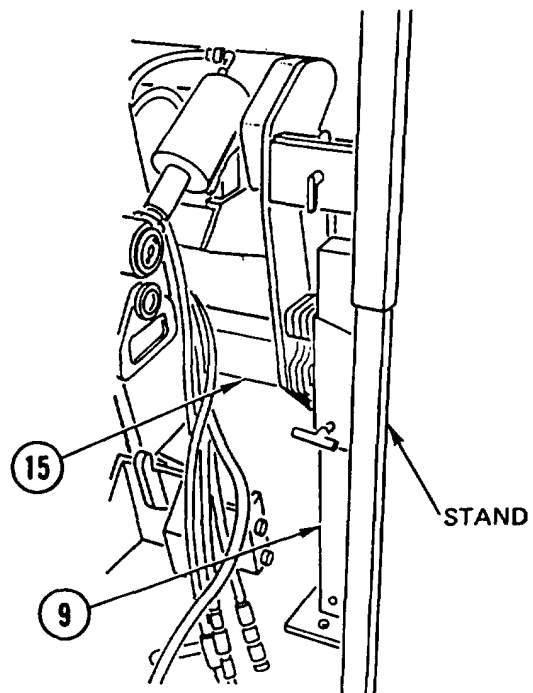

18. INSTALL two lock washers (14) and two mounting SCREWS (13) in forklift assembly (15).

FORKLIFT REPLACEMENT (CONT)

INSTALLATION

1. REMOVE two mounting SCREWS (1) and two lock washers (2) from forklift assembly (3). DISCARD lock WASHERS.

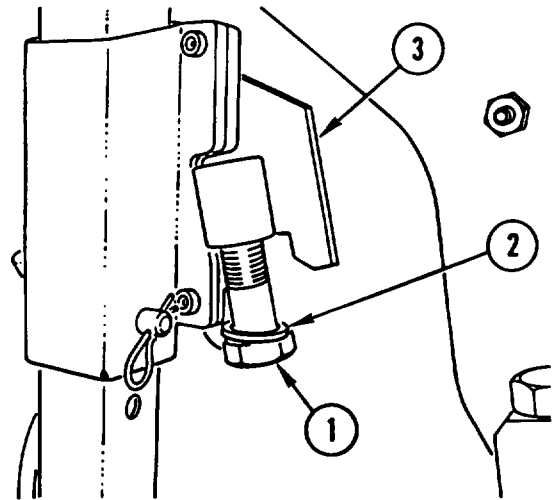

2. RAISE STANDS simultaneously until forklift assembly (3) weight is off forklift stabilizers (4).
3. RAISE forklift STABILIZERS (4) approximately 4 in. (10 cm) off ground and INSTALL PINS.

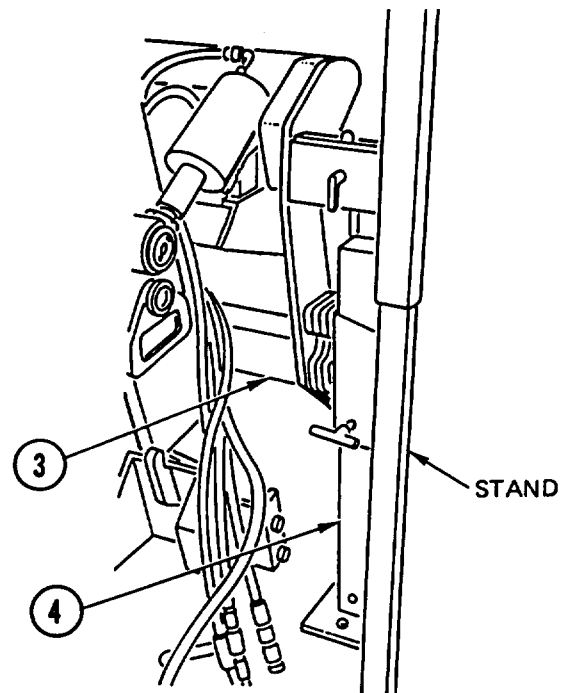

FORKLIFT REPLACEMENT (CONT)

WARNING

Tractor front wheels must be in line with forklift assembly prior to installation. If there is any contact between front wheels and forklift, reposition vehicle. Failure to do so could result in injury to personnel.

NOTE

Stands may have to be adjusted to allow vehicle to go under forklift assembly mounting bracket.

4. CAREFULLY ALINE VEHICLE with forklift assembly (3) and MOVE VEHICLE under forklift frame (5).

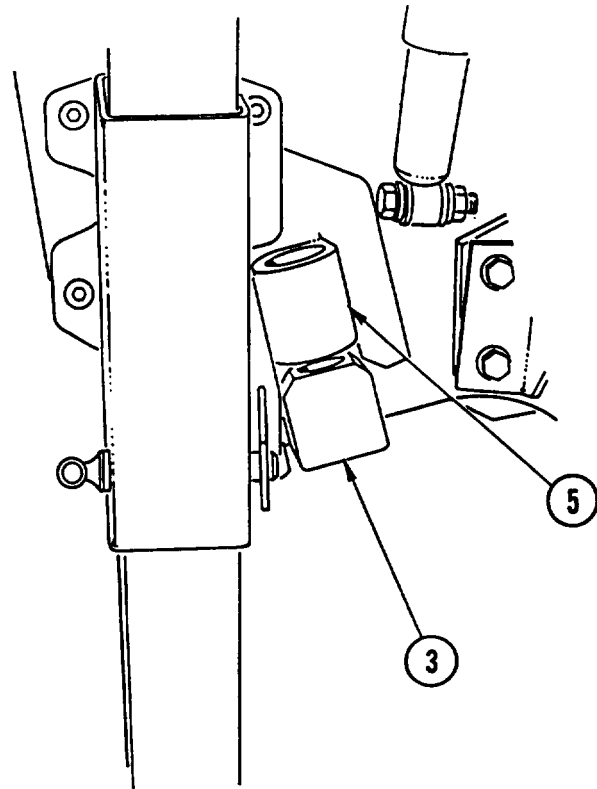

5. REMOVE CAPS or PLUGS. CONNECT three hydraulic HOSES (6).
6. TURN tilt cylinder shutoff VALVE (7) to OPEN position.
7. LOWER STANDS simultaneously until forklift assembly (3) is mounted on frame saddle (8).
8. INSTALL two new lock washers (2) and two mounting SCREWS (1). TIGHTEN SCREWS to 750 lb-ft (1016.9 N.m).

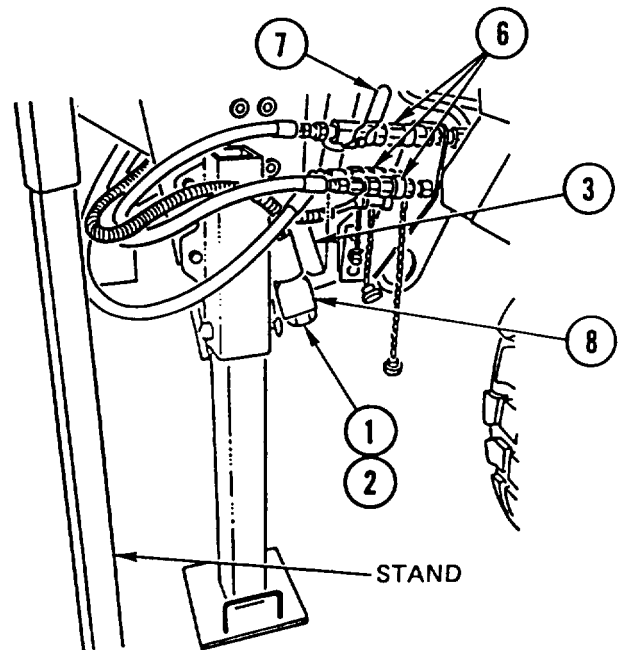

FORKLIFT REPLACEMENT (CONT)

9. REMOVE PINS, RAISE two forklift STABILIZERS (4), and INSTALL PINS.
10. TILT MAST (9) BACK until two forks (10) are level.

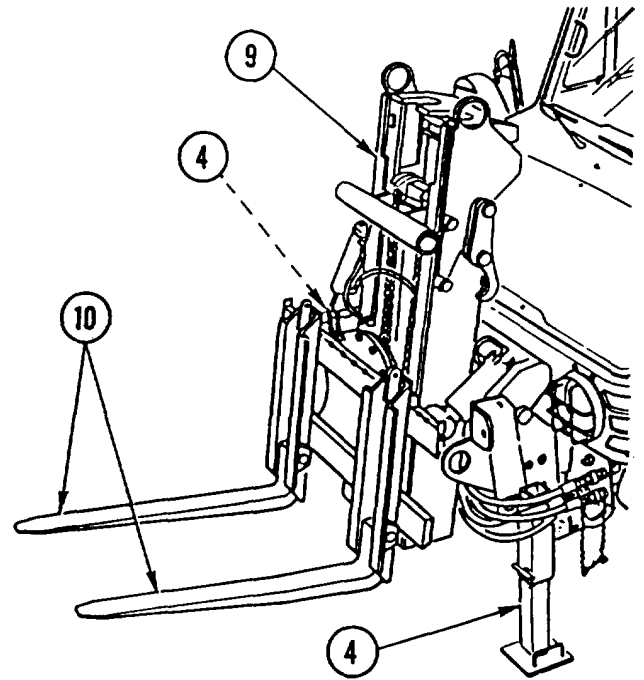

11. TURN mast lift cylinder hydraulic shutoff VALVE (11) to OPEN position.

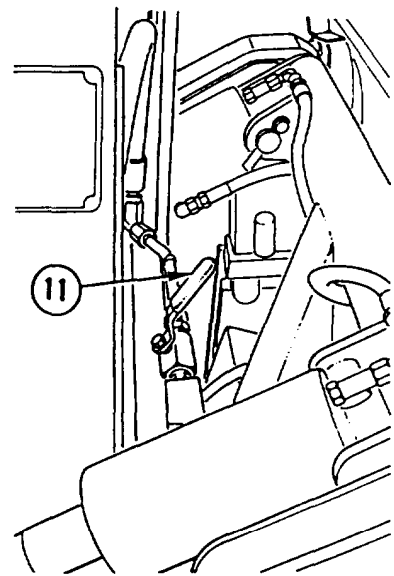

FORKLIFT REPLACEMENT (CONT)

12. RAISE CARRIAGE (12) to normal TRAVEL POSITION (TM 5-2420-224-10).
13. REMOVE two fork retaining PLATES (13) from storage position (14) and INSTALL on two FORKS (10).
14. MOVE two FORKS (10) into TRAVEL POSITION (TM 5-2420-224-10).
15. INSTALL **two** look PINS (15).
16. SHUT OFF ENGINE.

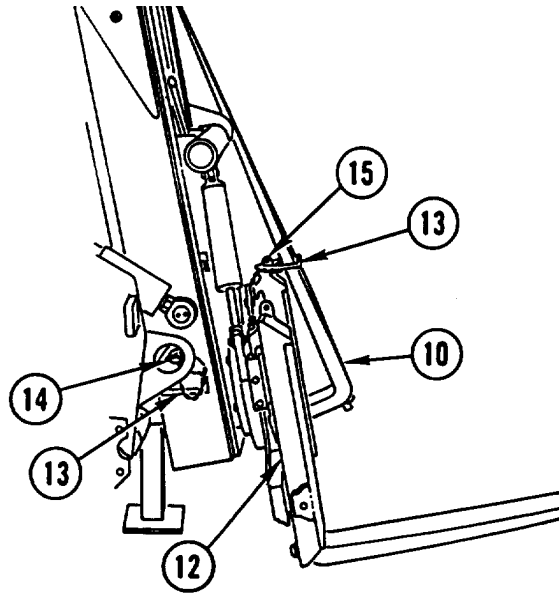

17. CONNECT electrical CONNECTOR (16).

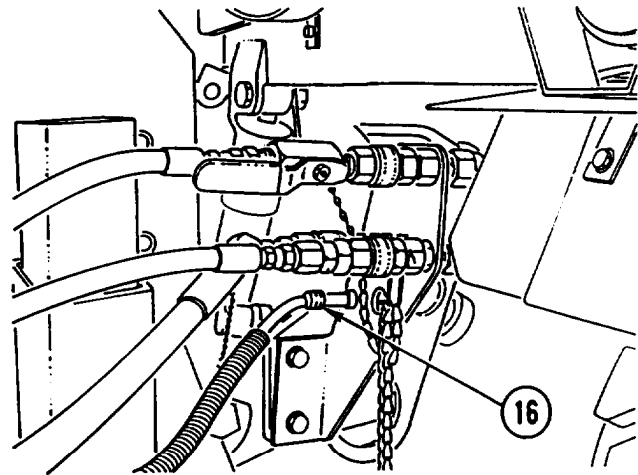

FORKLIFT ROTATOR REPLACEMENT

This task covers: a. Removal b. Installation

INITIAL SETUP

Applicable Configuration:

HMMH

Tools and Special Equipment:

Tool Kit, SC 5180-90-CL-N26

Materials/Parts:

Compound, Sealing Appendix C, Item 13

Personnel Required: (2)

Equipment Condition:

Reference

Page 4-563

Condition Description

Forklift Forks Removed

General Safety Instructions:

WARNING

Forklift face plate weighs 50 pounds (23 kilograms). To avoid personal injury, use a hoist or suitable lifting device when lifting forklift face plate.

REMOVAL

1. REMOVE safety pin (1) and PIN (2) and DISCONNECT rotator CYLINDER (3).

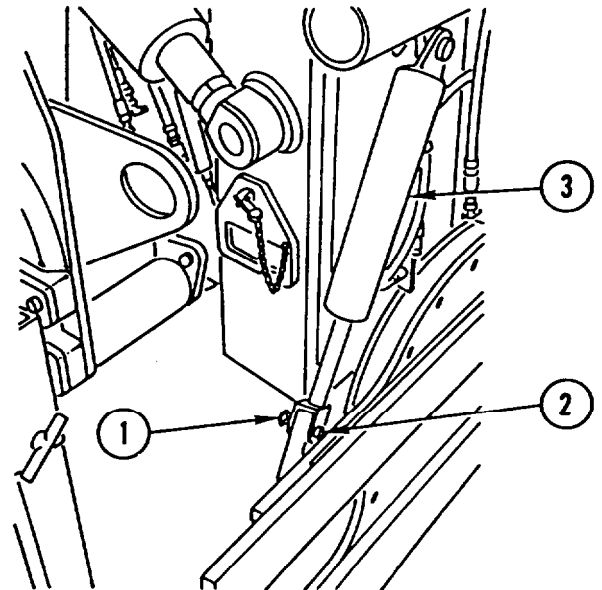

FORKLIFT ROTATOR REPLACEMENT (CONT)

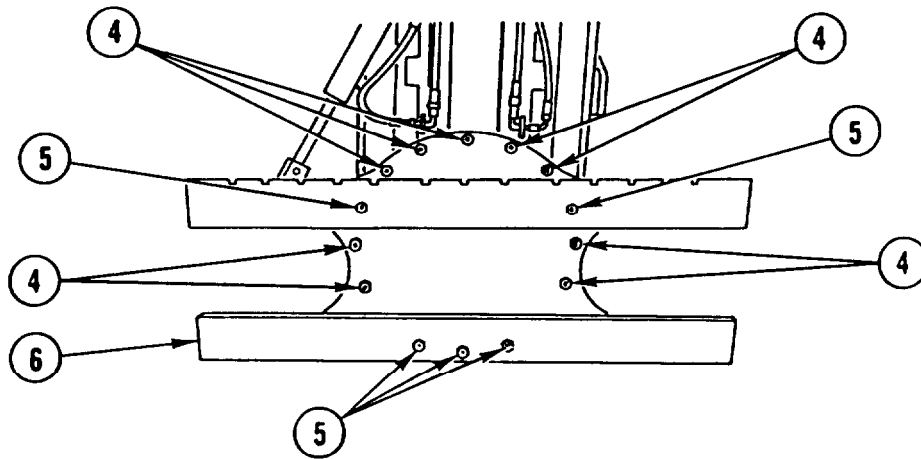

2. REMOVE nine socket head screws (4), five socket head screws (5), and face PLATE (6).

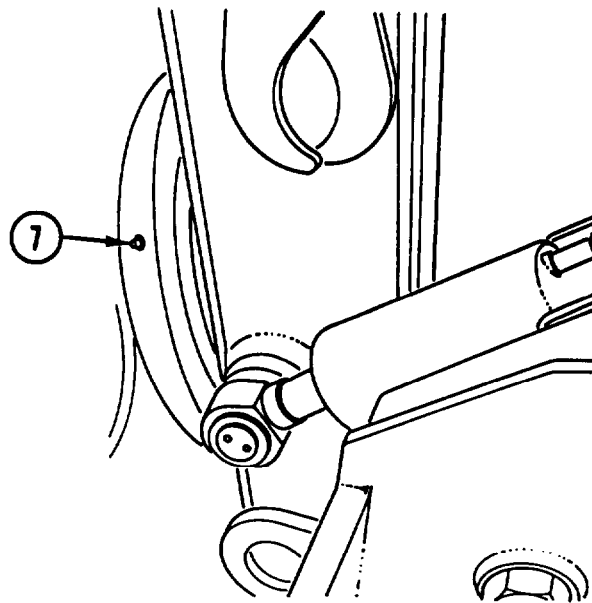

3. IF DAMAGED, REMOVE two lubrication FITTINGS (7).

FORKLIFT ROTATOR REPLACEMENT (CONT)

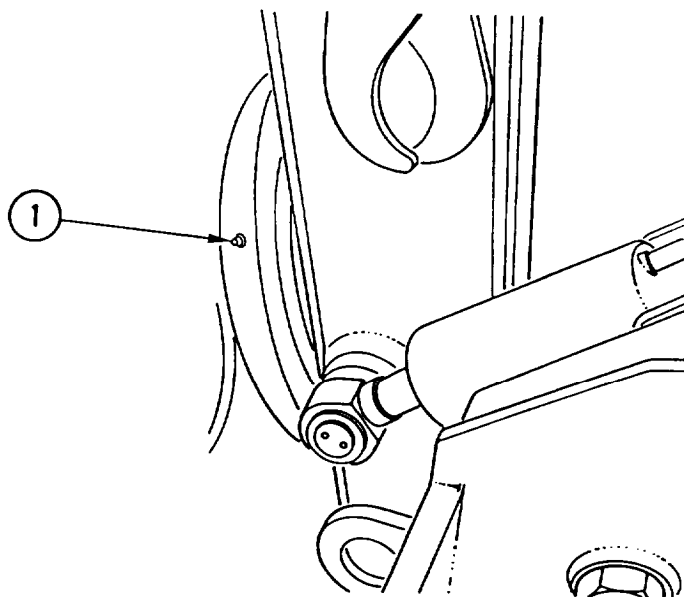
INSTALLATION

1. IF REMOVED, INSTALL two new lubrication FITTINGS (1).

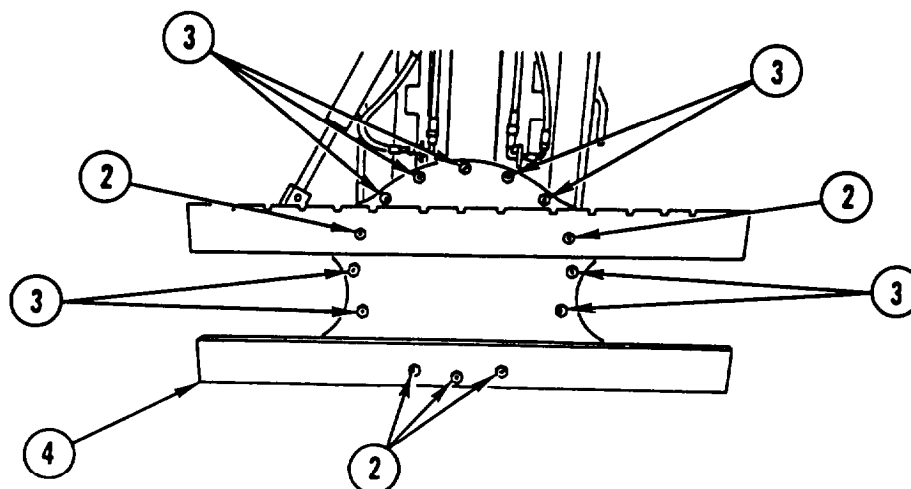
WARNING

Adhesive causes immediate bonding on contact with eyes, skin, or clothing and also gives off harmful vapors. Wear protective goggles and use in well-ventilated area. If adhesive gets in eyes, try to keep eyes open; flush eyes with water for 15 minutes and get immediate medical attention.

2. APPLY light COAT of SEALING COMPOUND to THREADS of 14 socket head screws (2 and 3).
3. INSTALL face PLATE (4), five socket head screws (2), and nine socket head screws (3).

FORKLIFT ROTATOR REPLACEMENT (CONT)

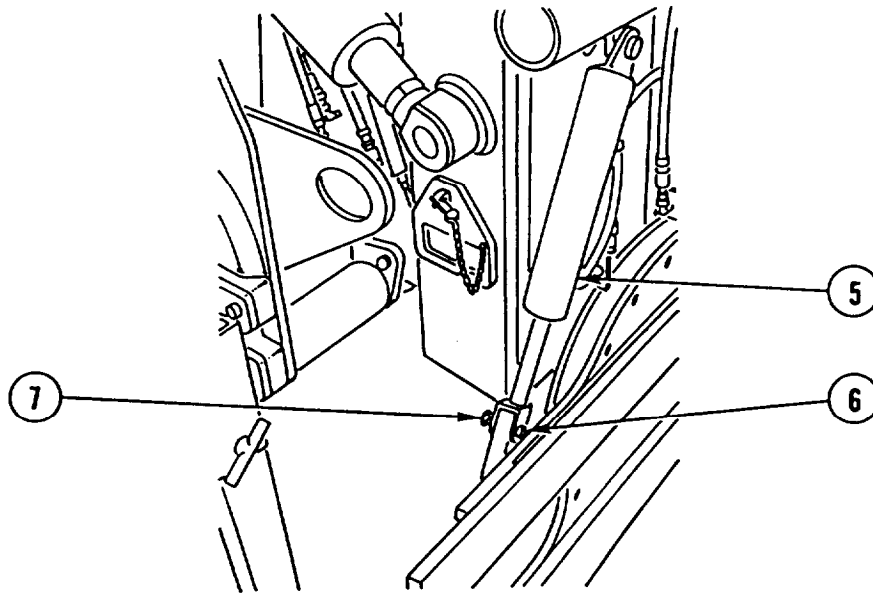

4. CONNECT rotator CYLINDER (5) and INSTALL PIN (6) and safety pin (7).

NOTE

Follow-on Maintenance:
Install forklift forks (page 4-563).

FORKLIFT CARRIAGE CHAIN ADJUSTMENT

This task covers: Adjustment

INITIAL SETUP

Applicable Configuration:

HMMH

Materials/Parts:

Pin, Cotter

Tools and Special Equipment:

Tool Kit, SC 5180-90-CL-N26

ADJUSTMENT

1. Lower carriage (1) to within 6 in. (152.4 mm) of floor level.
2. Check tension of both carriage chains (2); tension must be equal.

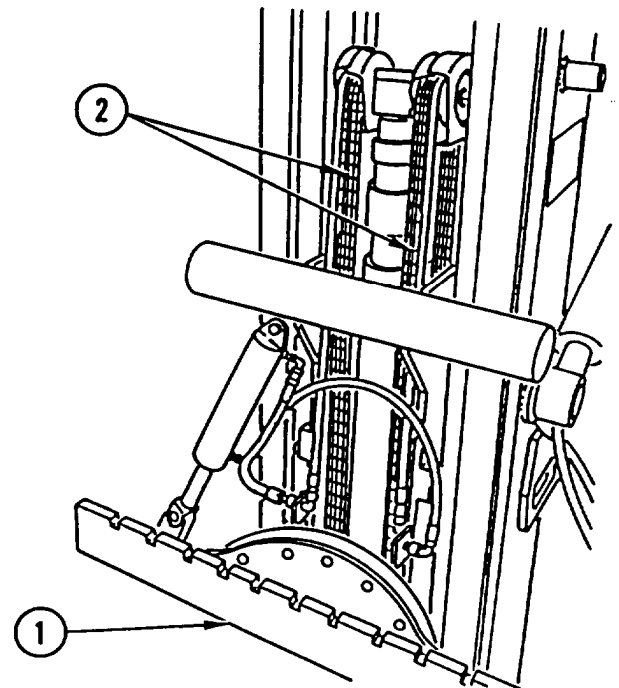

NOTE

- Perform step 3 if carriage chains have equal tension. If tension is not equal, go to step 4.
 - During performance of step 3, amount of allowable extension of lower bearing can be less than or equal to 1/2 of bearing diameter, but not more than 1/2 of bearing diameter.
3. Check that lower bearing (3) on each side extends below outer mast (4).

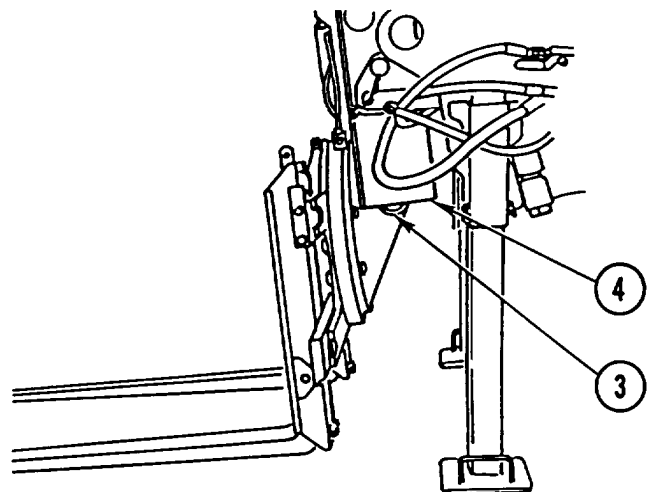

FORKLIFT CARRIAGE CHAIN ADJUSTMENT (CONT)

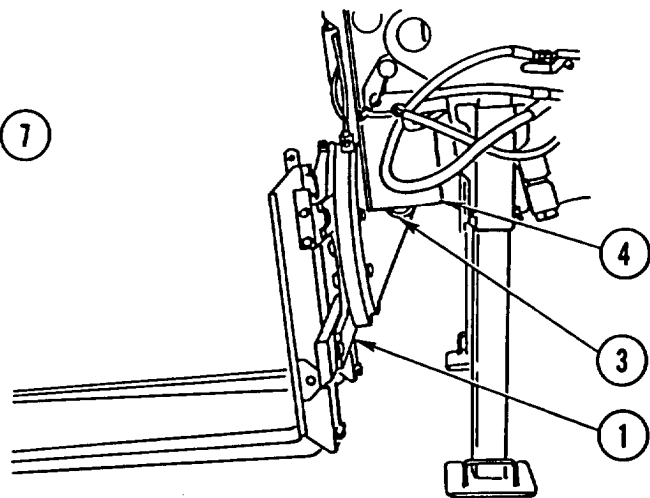
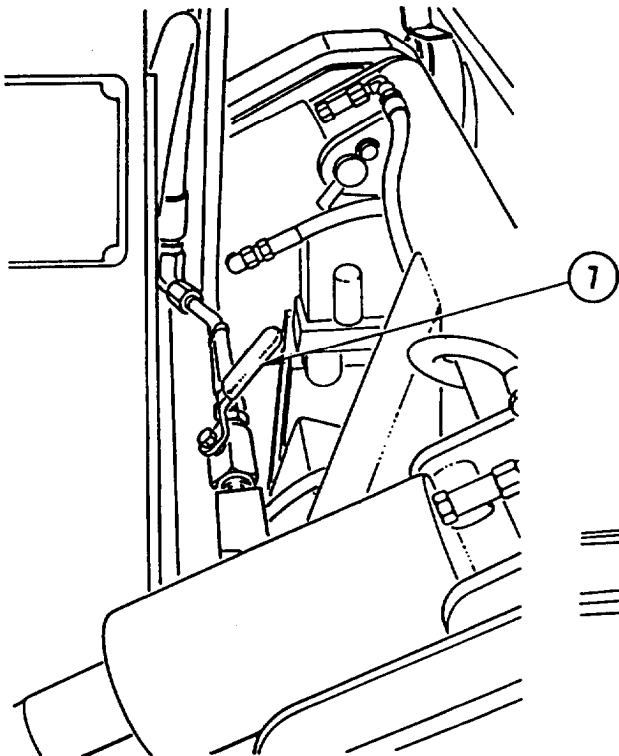
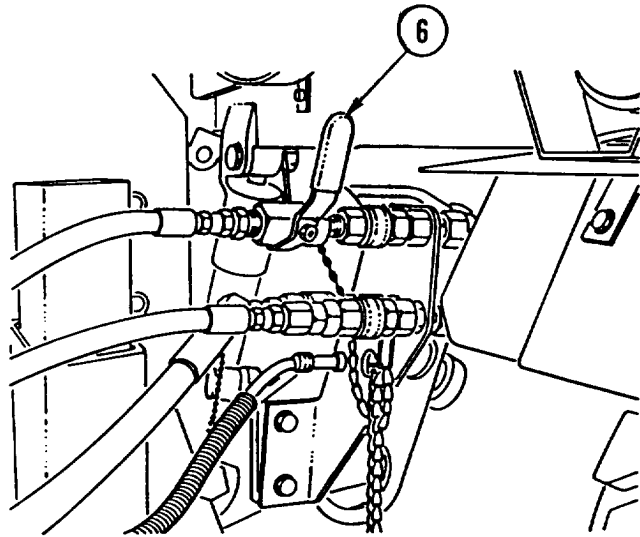
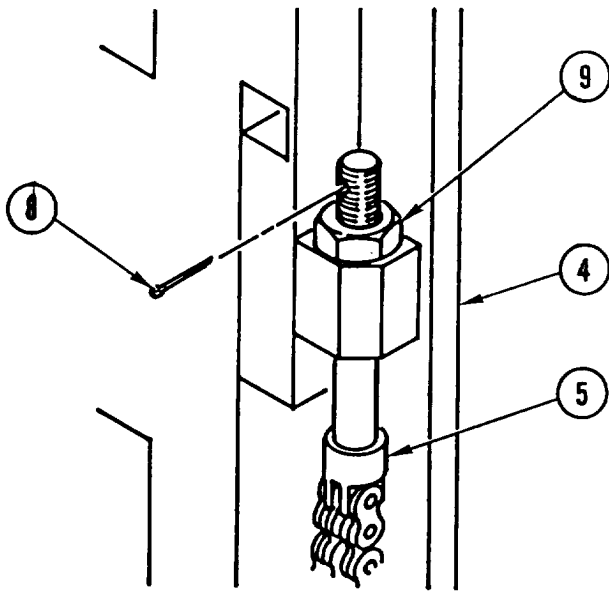

FORKLIFT CARRIAGE CHAIN ADJUSTMENT (CONT)

NOTE

Perform steps 4 thru 8 if step 2 check was not correct.

4. Raise mast (4) just enough to allow access to two carriage chain anchors (5).
5. Rotate two shutoff valves (6 and 7) to OFF position.
6. Remove and discard cotter pin (8) from carriage chain anchor (5) to be adjusted.
7. Tighten adjustment nut (9) until carriage chain tension is equal.
8. Rotate two shutoff valves (6 and 7) to ON position, lower carriage (1) to within 6 in. (152.4 mm) of floor level, and perform step 3.

NOTE

Perform steps 9 thru 13 if step 3 check was not correct.

9. Raise mast (4) just enough to allow access to two carriage chain anchors (k).
10. Rotate two shutoff valves (6 and 7) to OFF position.
11. Remove and discard two cotter pins (8) from two carriage chain anchors (5).

NOTE

During performance of step 12, amount of allowable extension of lower bearing can be less than or equal to 1/2 of bearing diameter, but not more than 1/2 of bearing diameter.

12. Tighten or loosen two adjustment nuts (9) until lower bearing (3) on each side extends below outer mast (4). Install new cotter pin(s) (8).
13. Rotate two shutoff valves (6 and 7) to ON position, lower carriage (1) to within 6 in. (152.4 mm) of floor level, and perform step 3.

FORKLIFT MAST CHAIN ADJUSTMENT

This task covers: Adjustment

INITIAL SETUP

Applicable Configuration:

HMMH

Tools and Special Equipment:

Tool Kit, SC 5180-90-CL-N26

ADJUSTMENT

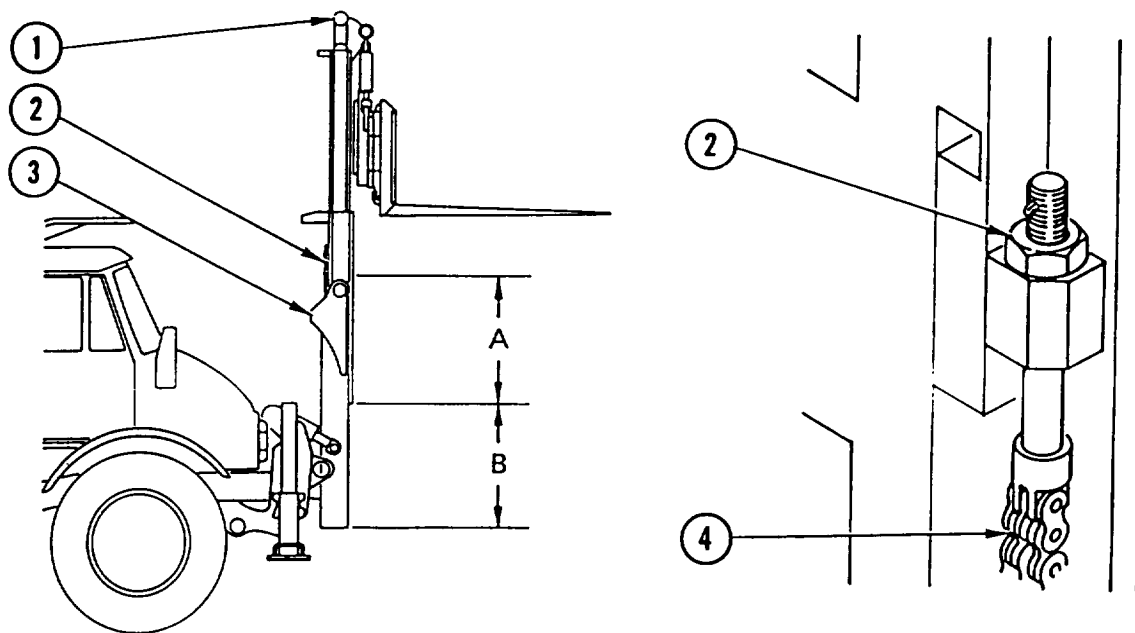

1. Raise mast (1) until mast chain adjusting nut (2) is just above outer upright (3).
2. Measure distance A and distance B. These two measurements must be equal $+1/8$ in.

NOTE

Perform steps 3 thru 5 only if step 2 measurements were not equal.

3. Tighten or loosen adjusting nut (2) on either mast chain (4) to achieve dimensions given in step 2.
4. Adjust other mast chain (4) until equal tension is achieved.
5. Lower mast (1). All channels should be even with each other $+1/8$ in.

FORKLIFT FORKS REPLACEMENT

This task covers: a. Removal b. Installation

INITIAL SETUP

Applicable Configuration:

HMMH

Tools and Special Equipment:

Tool Kit, SC 5180-90-CL-N26

Materials/Parts:

Washer, Lock (2)

Rivet

Personnel Required: (2)

References:

TM 5-2420-224-10

Equipment Condition:

Reference

TM 5-2420-224-10

Condition Description

Forklift Lowered to Ground

General Safety Instructions:

WARNING

Forklift fork assembly weighs 212 pounds (96 kilograms). To avoid personal injury, use a hoist or suitable lifting device when lifting forklift fork assembly.

REMOVAL

NOTE

Procedure is the same for both sides.

1. REMOVE two socket head capscrews (1), two lock washers (2), retaining PLATE (3), and fork assembly (4). DISCARD lock WASHERS.

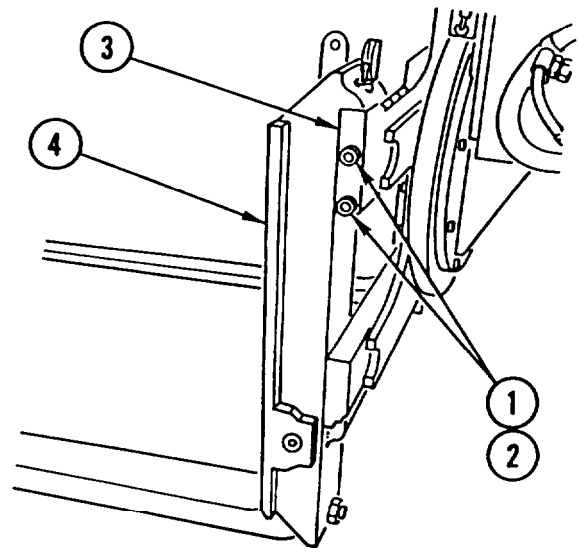

FORKLIFT FORKS REPLACEMENT (CONT)

2. REMOVE capscrew (5), pin (6), bolt (7), pin (8), and FORK (9).

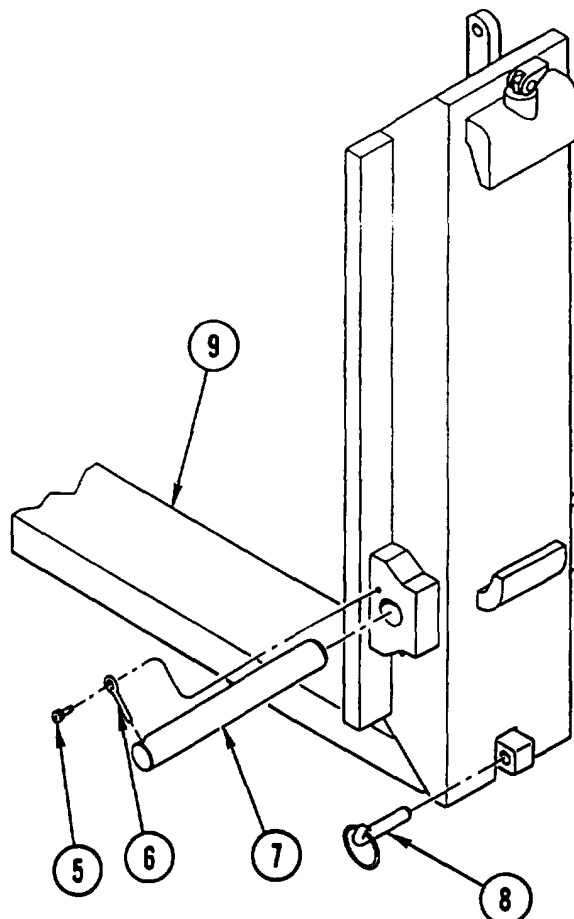

3. REMOVE rivet (10), BRACKET (11), pin (12), and spring (13). DISCARD RIVET.

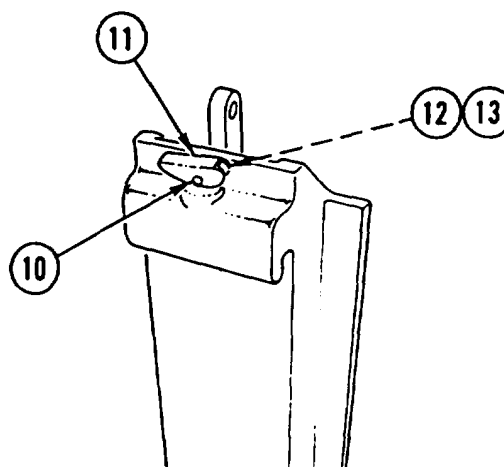

FORKLIFT FORKS REPLACEMENT (CONT)

INSTALLATION

NOTE

Procedure is the same for both sides.

1. INSTALL spring (1), pin (2), BRACKET (3), and new rivet (4).

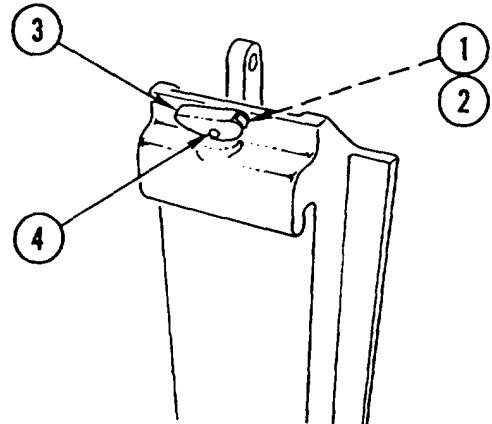

2. INSTALL FORK (5), pin (6), bolt (7), pin (8), and capscrew (9).

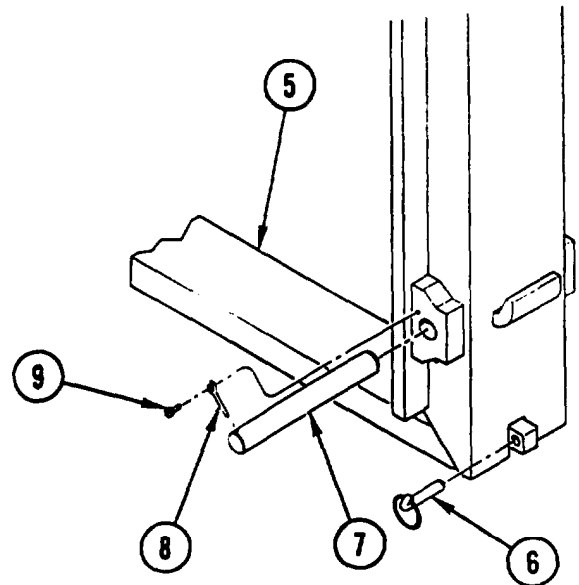

3. INSTALL fork assembly (10), retaining PLATE (11), two new lock washers (12), and two socket head capscrews (13).

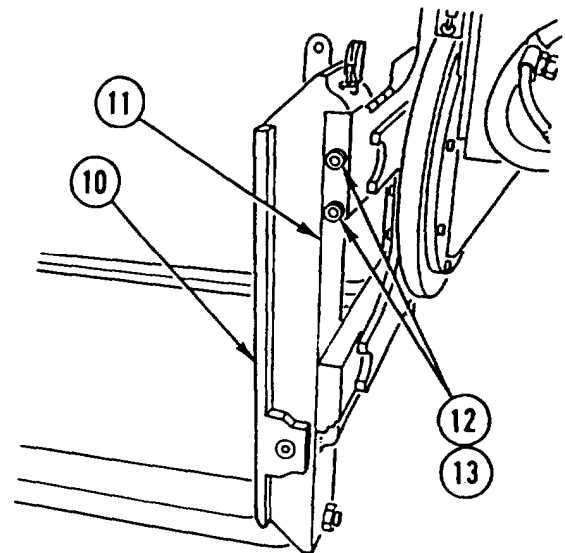

FORKLIFT TRAVEL LOCK REPLACEMENT

This task covers: a. Removal b. Installation

INITIAL SETUP

Applicable Configuration:

HMMH

References:

TM 5-2420-224-10

Equipment Condition:

Reference

TM 5-2420-224-10

Condition Description

Forklift Lowered to Ground

REMOVAL

REMOVE two quick-release pins (1) and two locking PLATES (2).

INSTALLATION

INSTALL two locking PLATES (2) and two quick-release pins (1).

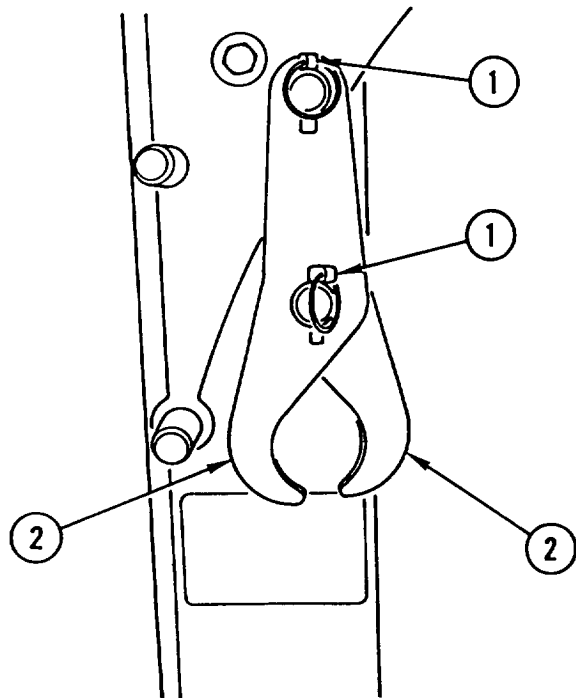

FORKLIFT FRONT OUTRIGGER REPLACEMENT

This task covers: a. Removal b. Installation

INITIAL SETUP

Applicable Configuration:

HMMH

Tools and Special Equipment:

Tool Kit, SC 5180-90-CL-N26

References:

TM 5-2420-224-10

Equipment Condition:

Reference

TM 5-2420-224-10

Condition Description

Forklift Lowered to Ground

REMOVAL

NOTE

Procedure is the same for both outriggers.

1. REMOVE four cap socket screws (1) and COUPLING (2),
2. REMOVE pin (3), pin (4), and JACK (5) from COUPLING (2).
3. REMOVE chain RETAINER (6) from pin (4).

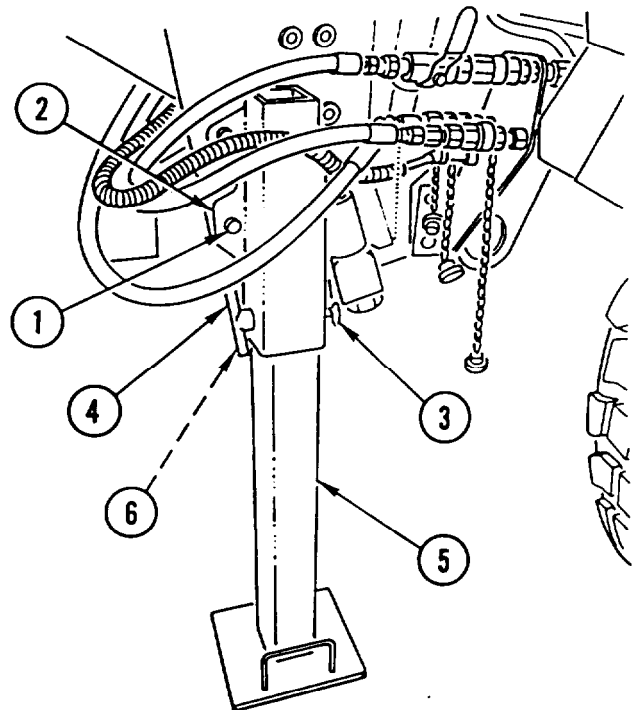

INSTALLATION

NOTE

Procedure is the same for both outriggers.

1. INSTALL chain RETAINER (6) on pin (4).
2. INSTALL JACK (5), pin (4), and pin (3) in COUPLING (2).
3. INSTALL COUPLING (2) and four cap socket screws (1).

FRONT LOADER HYDRAULIC RELIEF VALVE REPLACEMENT

This task covers: a. Removal b. Installation

INITIAL SETUP

Applicable Configuration:

SEE

Tools and Special Equipment:

Shop Equipment, SC 4910-95-CL-A74
Tool Kit, SC 5180-90-CL-N26

Materials/Parts:

Rags Appendix C, Hem 32

References:

TM 5-2420-224-10

Equipment Condition:

Reference	Condition Description
TM 5-2420-224-10	Loader Bucket Lowered to Ground
Page 2-23	Hydraulic Pressure Relieved

General Safety Instructions:

WARNING

- High pressure hydraulics [oil under 2450 psi (16,893 kPa)] operate this equipment. Never disconnect any hydraulic line or fitting without first dropping pressure to zero. A high pressure oil stream can pierce body and cause severe injury to personal.
- Fuel and oil are slippery and can cause falls. To avoid personal injury, wipe up spilled fuel or oil with rags.

REMOVAL

1. DISCONNECT two NUTS (1) and REMOVE VALVE (2).
2. REMOVE two ELBOWS (3).

INSTALLATION

1. INSTALL two ELBOWS (3).

NOTE

Make sure arrow on valve is toward driver's side of vehicle.

2. INSTALL VALVE (2) and CONNECT two NUTS (1).

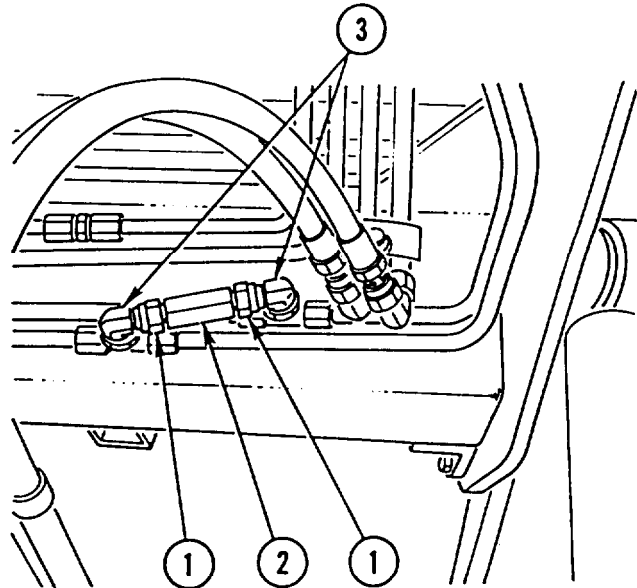

LEFT LOADER BOOM CYLINDER HYDRAULIC LINES AND FITTINGS REPLACEMENT

This task covers: a. Removal b. Installation

INITIAL SETUP

Applicable Configuration:

SEE

Tools and Special Equipment:

Shop Equipment, SC 4910-95-CL-A74
 Tool Kit, SC 5180-90-CL-N26

Materials/Parts:

Packing (AR)

Washer, Lock (AR)

Caps and Plugs Appendix C, Item 7

Rags Appendix C, item 32

References:

TM 5-2420-224-10

Equipment Condition:

Reference	Condition Description
TM 5-2420-224-10	Loader Bucket Lowered to Ground
Page 2-23	Hydraulic Pressure Relieved

General Safety Instructions:

W A R N I N G

- High pressure hydraulics [oil under 2450 psi (16,893 kPa)] operate this equipment. Never disconnect any hydraulic line or fitting without first dropping pressure to zero. A high pressure oil stream can pierce body and cause severe injury to personnel.
- Fuel and oil are slippery and can cause falls. To avoid injury, wipe up spilled fuel or oil with rags.

LEFT LOADER BOOM CYLINDER HYDRAULIC LINES AND FITTINGS REPLACEMENT (CONT)

REMOVAL

CAUTION

Cap or plug all ports and ends of hoses and tubes to prevent contamination of hydraulic oil. Failure to do so may result in damage to equipment.

NOTE

- Tag lines prior to removal to aid in installation.
- Discard packing(s) and lock washer(s).

REMOVE left loader boom cylinder hydraulic LINES and FITTINGS using illustration and legend as a guide.

INSTALLATION

NOTE

Install new packing(s) and new lock washer(s).

INSTALL left loader boom cylinder hydraulic LINES and FITTINGS using illustration and legend as a guide.

LEGEND

- 1 Hose assembly (2)
- 2 Elbow (2)
- 3 Screw
- 4 Lock washer
- 5 Washer
- 6 Clamp
- 7 Tube assembly
- 8 Tube assembly
- 9 Elbow
- 10 Screw
- 11 Lock washer
- 12 Filter-strainer
- 13 Packing (2)
- 14 Elbow (2)
- 15 Tube assembly (2)
- 16 Hose clamp (2)
- 17 Saddle clamp (2)
- 18 Elbow (2)
- 19 Clamp (2)
- 20 Screw
- 21 Lock washer
- 22 Nut

LEFT LOADER BOOM CYLINDER HYDRAULIC LINES AND FITTINGS REPLACEMENT (CONT)

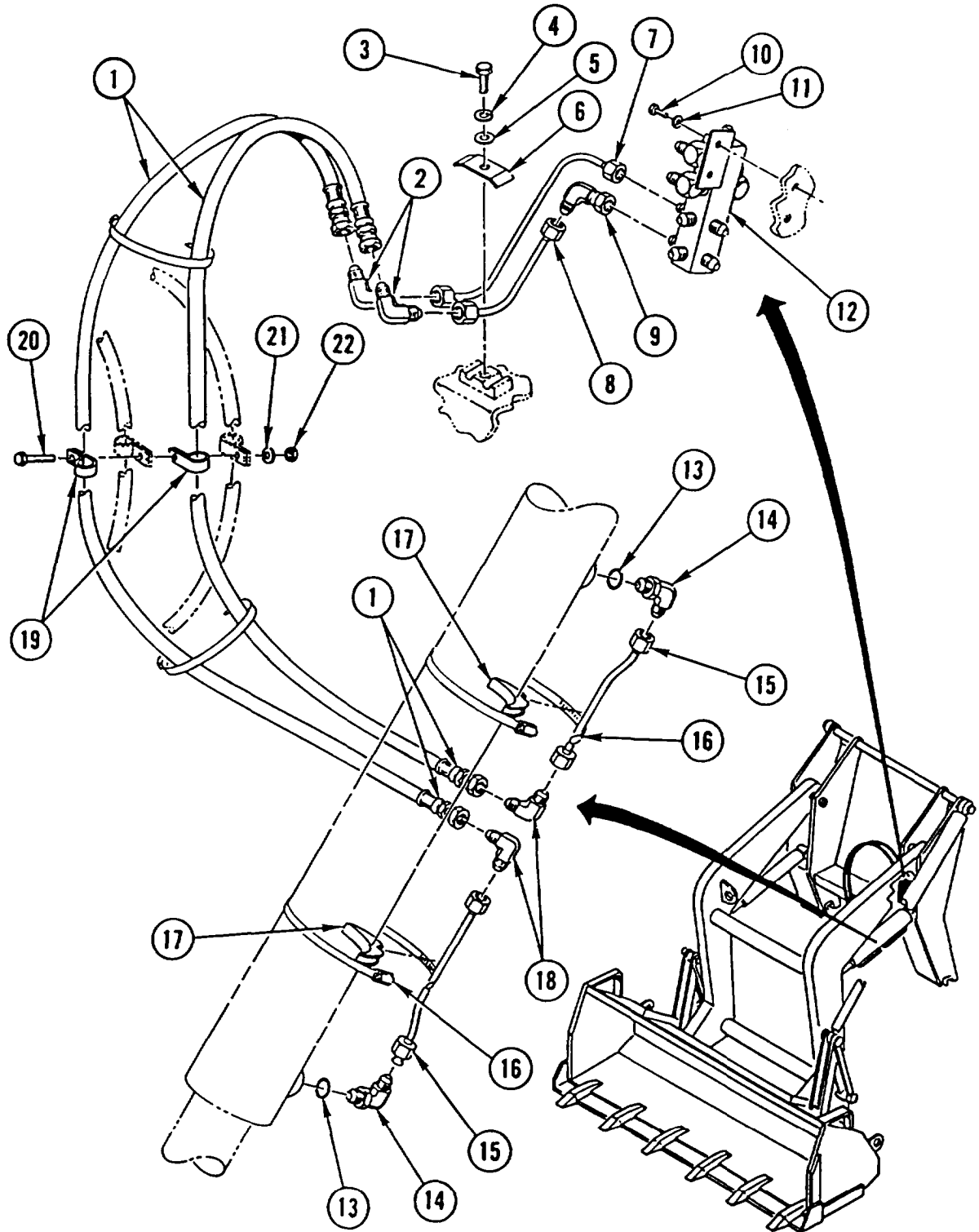

RIGHT LOADER BOOM CYLINDER HYDRAULIC LINES AND FITTINGS REPLACEMENT

This task covers: a. Removal b. Installation

INITIAL SETUP

Applicable Configuration:

SEE

Tools and Special Equipment:

Shop Equipment, SC 4910-95-CL-A74
 Tool Kit, SC 5180-90-CL-N26

Materials/Parts:

Packing (AR)

Washer, Lock (AR)

Caps and Plugs Appendix C, Item 7

Rags Appendix C, Item 32

References:

TM 5-2420-224-10

Equipment Condition:

Reference	Condition Description
TM 5-2420-224-10	Loader Bucket Lowered to Ground
Page 2-23	Hydraulic Pressure Relieved

General Safety Instructions:

W A R N I N G

- High pressure hydraulics [oil under 2450 psi (16,893 kPa)] operate this equipment. Never disconnect any hydraulic line or fitting without first dropping pressure to zero. A high pressure oil stream can pierce body and cause severe injury to personnel.
- Fuel and oil are slippery and can cause falls. To avoid injury, wipe up spilled fuel or oil with rags.

REMOVAL

CAUTION

Cap or plug all ports and ends of hoses and tubes to prevent contamination of hydraulic oil. Failure to do so may result in damage to equipment.

NOTE

- Tag lines prior to removal to aid in installation.
- Discard packing(s) and lock washer.

REMOVE right loader boom cylinder hydraulic LINES and FITTINGS using illustration and legend as a guide.

RIGHT LOADER BOOM CYLINDER HYDRAULIC LINES AND FITTINGS REPLACEMENT (CONT)

INSTALLATION

NOTE

- Install new packing(s) and new lock washer.
- Make sure arrow on relief valve is toward driver's side of vehicle.

INSTALL right loader boom cylinder hydraulic LINES and FITTINGS using illustration and legend as a guide.

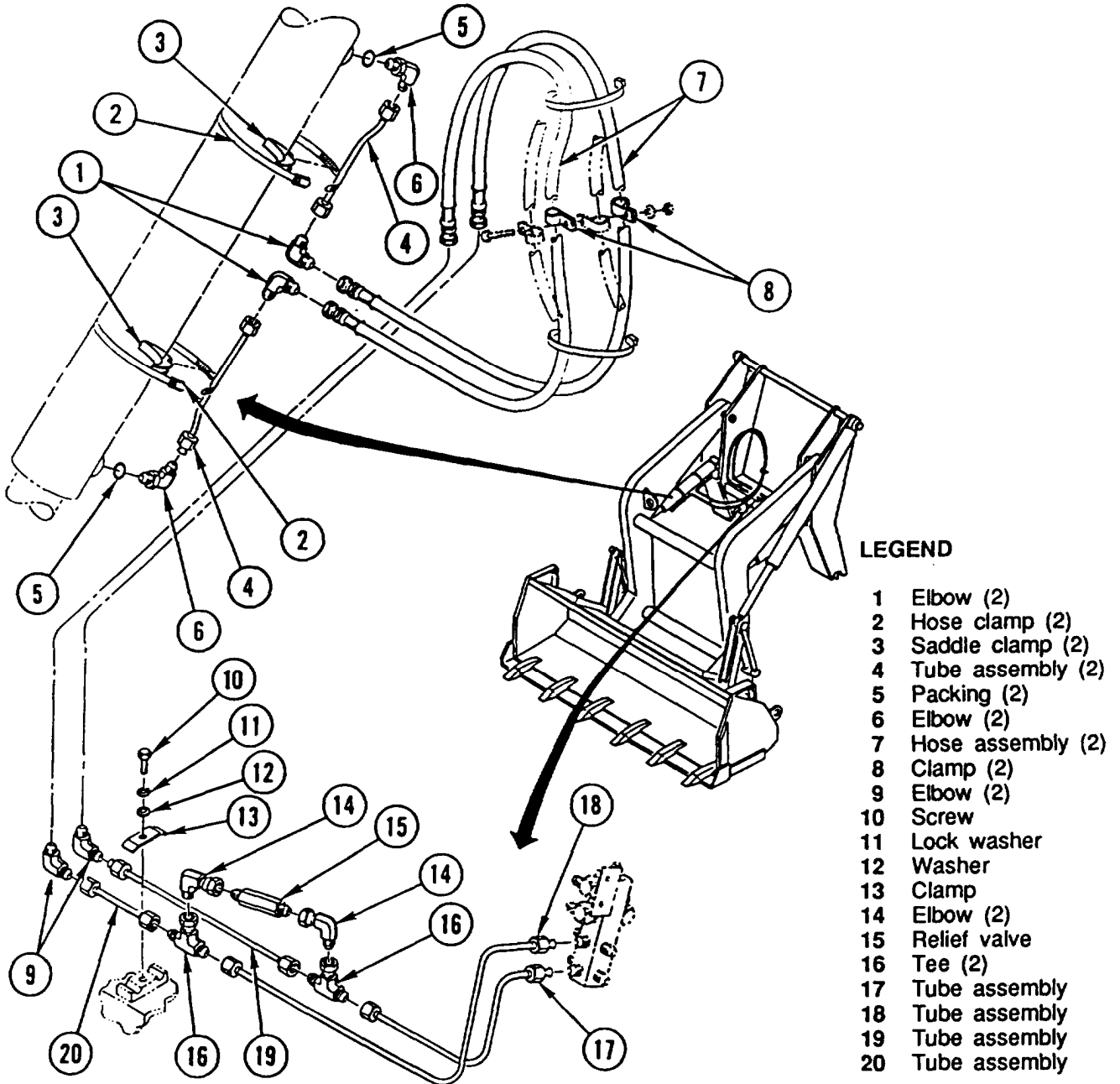

LEFT LOADER BUCKET ROLLBACK CYLINDER HYDRAULIC LINES AND FITTINGS REPLACEMENT

This task covers: a. Removal b. installation

INITIAL SETUP

Applicable Configuration:

SEE

Tools and Special Equipment:

Shop Equipment, SC 4910-95-CL-A74
Tool Kit, SC 5180-90-CL-N26

Materials/Parts:

Packing (AR)

Washer, Lock (AR)

Caps and Plugs Appendix C, Item 7

Rags Appendix C, Item 32

References:

TM 5-2420-224-10

Equipment Condition:

Reference	Condition Description
TM 5-2420-224-10	Loader Bucket Lowered to Ground
Page 2-23	Hydraulic Pressure Relieved

General Safety Instructions:

WARNING

- High pressure hydraulics [oil under 2450 psi (16893 kPa)] operate this equipment. Never disconnect any hydraulic line or fitting without first dropping pressure to zero. A high pressure oil stream can pierce body and cause severe injury to personnel.
- Fuel and oil are slippery and can cause falls. To avoid injury, wipe up spilled fuel or oil with rags.

REMOVAL

CAUTION

Cap or plug all ports and ends of hoses and tubes to prevent contamination of hydraulic oil. Failure to do so may result in damage to equipment.

NOTE

- Tag lines prior to removal to aid in installation.
- Discard packing(s) and lock washer.

REMOVE left loader bucket rollback cylinder hydraulic LINES and FITTINGS using illustration and legend as a guide.

LEFT LOADER BUCKET ROLLBACK CYLINDER HYDRAULIC LINES AND FITTINGS REPLACEMENT (CONT)

INSTALLATION

NOTE

Install new packing(s) and new lock washer.

INSTALL left loader bucket rollback cylinder hydraulic LINES and FITTINGS using illustration and legend as a guide.

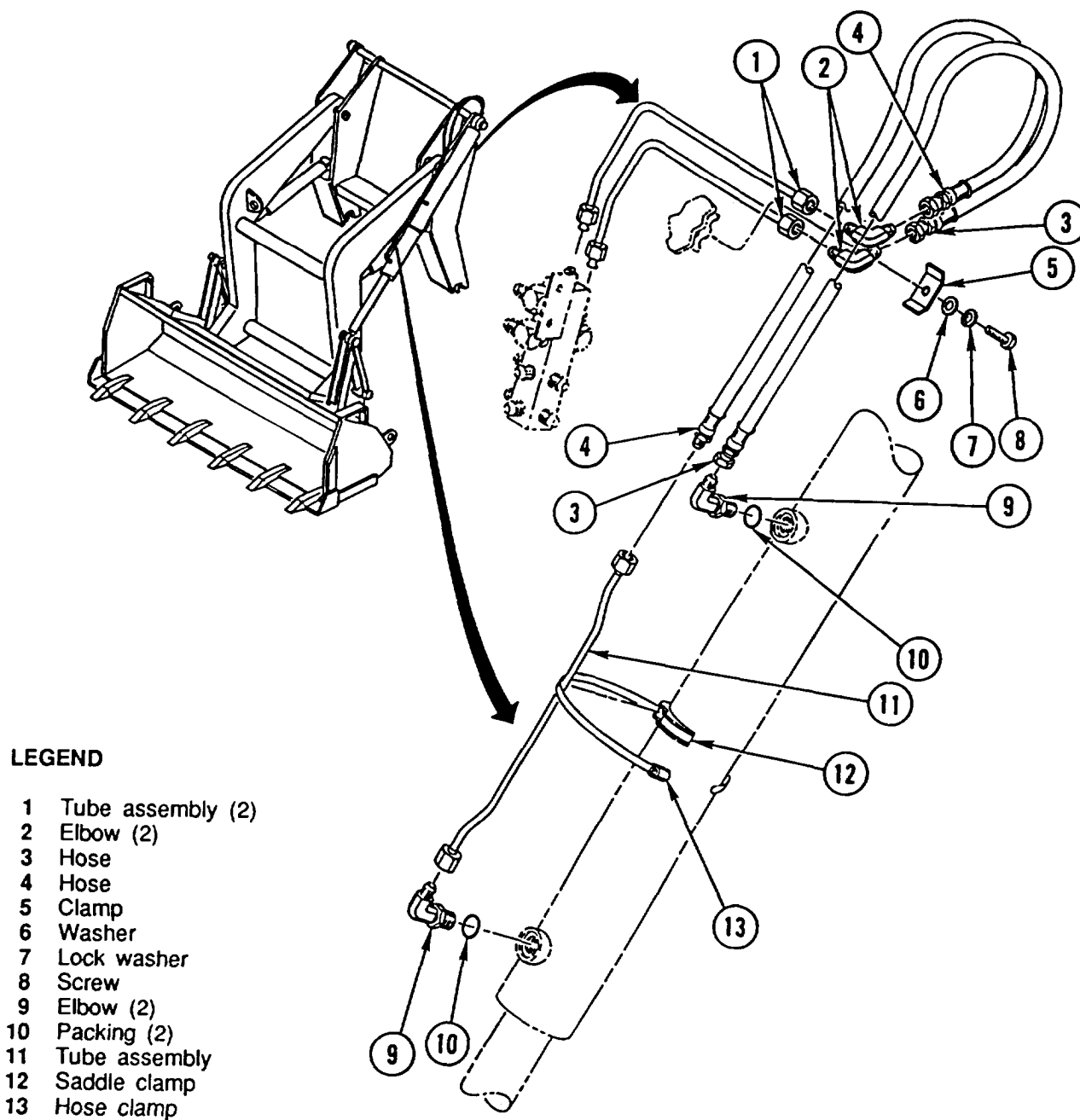

RIGHT LOADER BUCKET ROLLBACK CYLINDER HYDRAULIC LINES AND FITTINGS REPLACEMENT

This task covers: a. Removal b. Installation

INITIAL SETUP

Applicable Configuration:

SEE

Tools and Special Equipment:

Shop Equipment, SC 4910-95-CL-A74
Tool Kit, SC 5180-90-CL-N26

Materials/Parts:

Packing (AR)

Washer, Lock (AR)

Caps and Plugs Appendix C, Item 7

Rags Appendix C, Item 32

References:

TM 5-2420-224-10

Equipment Condition:

Reference	Condition Description
TM 5-2420-224-10	Loader Bucket Lowered to Ground
Page 2-23	Hydraulic Pressure Relieved

General Safety Instructions:

WARNING

- High pressure hydraulics [oil under 2450 psi (16,893 kpa)] operate this equipment. Never disconnect any hydraulic line or fitting without first dropping pressure to zero. A high pressure oil stream can pierce body and cause severe injury to personnel.
- Fuel and oil are slippery and can cause falls. To avoid injury, wipe up spilled fuel or oil with rags.

REMOVAL

CAUTION

Cap or plug all ports and ends of hoses and tubes to prevent contamination of hydraulic oil. Failure to do so may result in damage to equipment.

NOTE

- Tag lines prior to removal to aid in installation.
- Discard packing(s) and lock washer(s).

REMOVE right loader bucket rollback cylinder hydraulic LINES and FITTINGS using illustration and legend as a guide.

RIGHT LOADER BUCKET ROLLBACK CYLINDER HYDRAULIC LINES AND FITTINGS REPLACEMENT (CONT)

INSTALLATION

NOTE

Install new packing(s) and new lock washer(s).

INSTALL right loader bucket rollback cylinder hydraulic LINES and FITTINGS using illustration and legend as a guide.

LEGEND

- 1 Tube assembly
- 2 Elbow (2)
- 3 Packing (2)
- 4 Hose assembly
- 5 Hose assembly
- 6 Elbow (2)
- 7 Tube assembly (2)
- 8 Clamp (2)
- 9 Washer (2)
- 10 Lock washer (2)
- 11 Screw (2)
- 12 Nipple (2)
- 13 Tube assembly (2)
- 14 Hose clamp
- 15 Saddle clamp

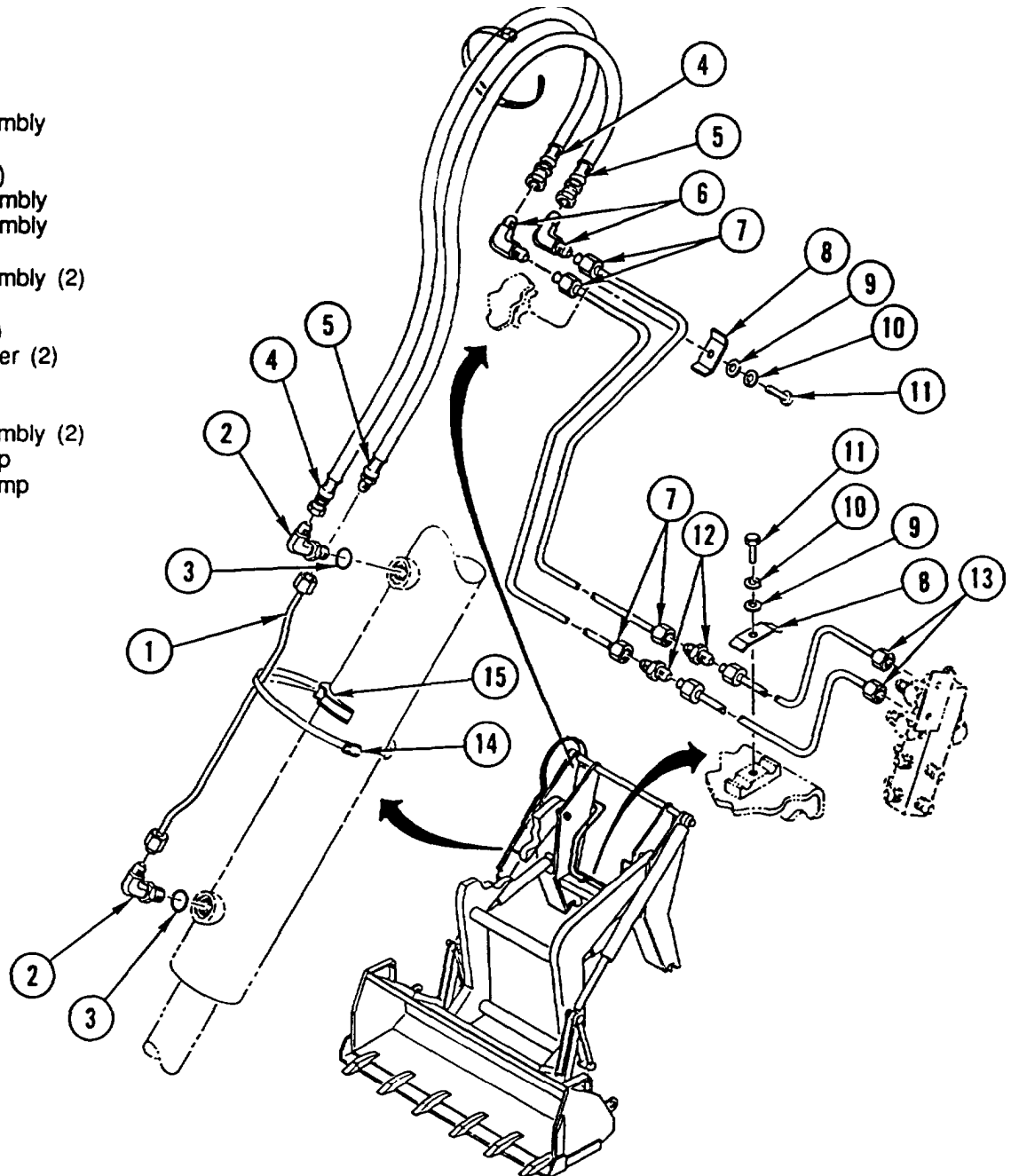

FRONT LOADER HYDRAULIC LINES AND FITTINGS REPLACEMENT

This task covers: a. Removal b. Installation

INITIAL SETUP

Applicable configuration:

SEE

Tools and Special Equipment:

Shop Equipment, SC 4910-95-CL-A74
Tool Kit, SC 5180-90-CL-N26

Materials/Parts:

Washer, Lock (AR)

Caps and Plugs Appendix C, Item 7

Rags Appendix C, Item 32

References:

TM 5-2420-224-10

Equipment Condition:

Reference	Condition Description
TM 5-2420-224-10	Loader Bucket Lowered to Ground
Page 2-23	Hydraulic Pressure Relieved

General Safety Instructions:

WARNING

- High pressure hydraulics [oil under 2450 psi (16,893 kPa)] operate this equipment. Never disconnect any hydraulic line or fitting without first dropping pressure to zero. A high pressure oil stream can pierce body and cause severe injury to personnel.
- Fuel and oil are slippery and can cause falls. To avoid injury, wipe up spilled fuel or oil with rags.

REMOVAL

CAUTION

Cap or plug all ports and ends of hoses and tubes to prevent contamination of hydraulic oil. Failure to do so may result in damage to equipment.

NOTE

- Tag lines prior to removal to aid in installation.
- Discard lock washer.

REMOVE front loader hydraulic LINES and FITTINGS using illustration and legend as a guide.

FRONT LOADER HYDRAULIC LINES AND FITTINGS REPLACEMENT (CONT)

INSTALLATION

NOTE

Install new lock washer.

INSTALL front loader hydraulic LINES and FITTINGS using illustration and legend as a guide.

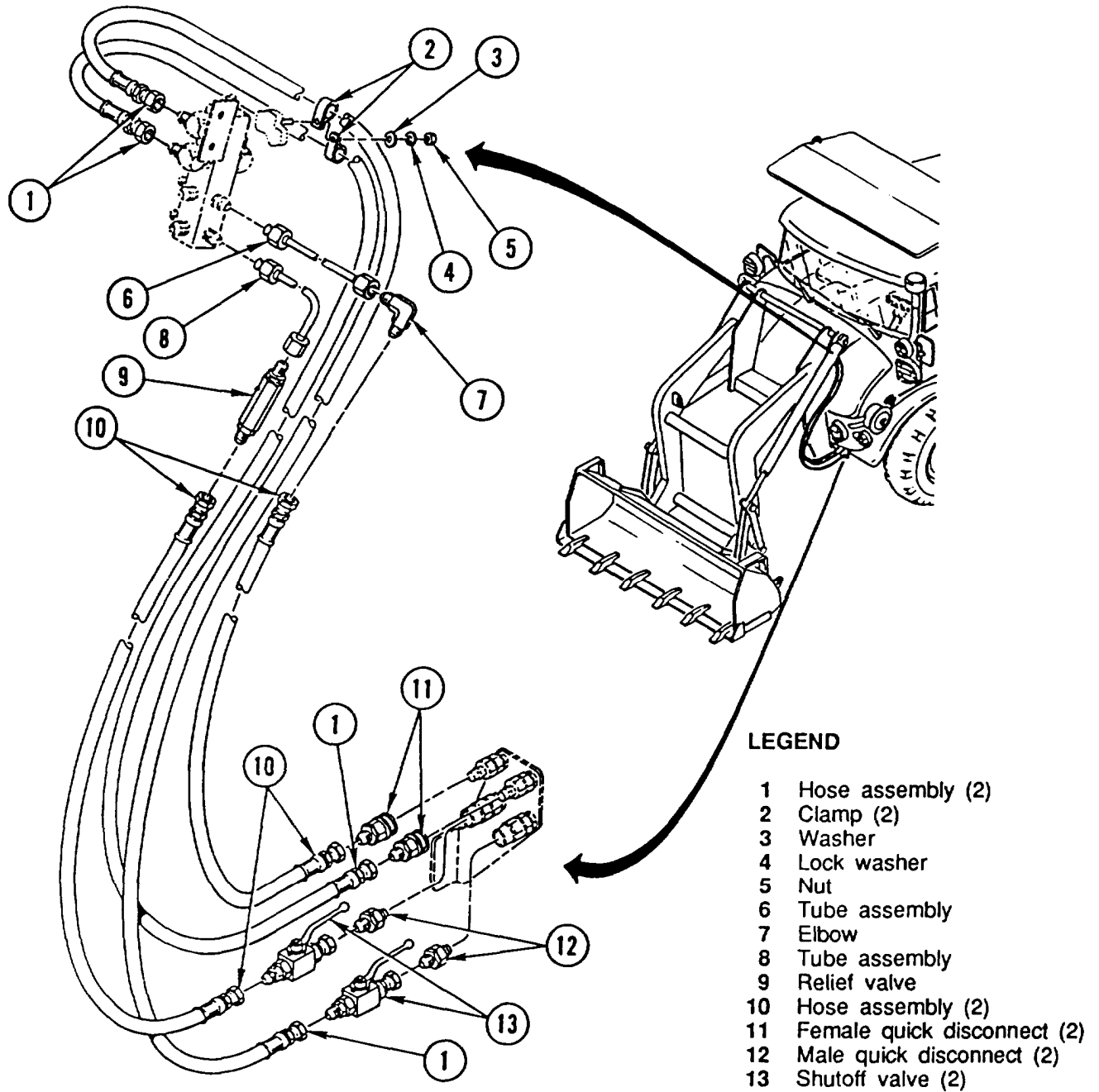

- LEGEND**
- 1 Hose assembly (2)
 - 2 Clamp (2)
 - 3 Washer
 - 4 Lock washer
 - 5 Nut
 - 6 Tube assembly
 - 7 Elbow
 - 8 Tube assembly
 - 9 Relief valve
 - 10 Hose assembly (2)
 - 11 Female quick disconnect (2)
 - 12 Male quick disconnect (2)
 - 13 Shutoff valve (2)

FRONT LOADER/FORKLIFT HYDRAULIC LINES AND FITTINGS REPLACEMENT

This task covers: a. Removal b. Installation

INITIAL SETUP

Tools and Special Equipment:

Shop Equipment, SC 4910-95-CL-A74
Tool Kit, SC 5180-90-CL-N26

Materials/Parts:

Packing (AR)

Washer, Lock (AR)

Caps and Plugs Appendix C, Item 7

Rags Appendix C, Item 32

References:

TM 5-2420-224-10

Equipment Condition:

Reference	Condition Description
TM 5-2420-224-10	Loader Bucket (SEE) or Forklift (HMMH) Lowered to Ground
Page 2-23	Hydraulic Pressure Relieved

General Safety Instructions:

WARNING

- High pressure hydraulics [oil under 2450 psi (16,893 kPa)] operate this equipment. Never disconnect any hydraulic line or fitting without first dropping pressure to zero. A high pressure oil stream can pierce body and cause severe injury to personnel.
- Fuel and oil are slippery and can cause falls. To avoid injury, wipe up spilled fuel or oil with rags.

REMOVAL

CAUTION

Cap or plug all ports and ends of hoses and tubes to prevent contamination of hydraulic oil. Failure to do so may result in damage to equipment.

NOTE

- Procedure is the same for both vehicles.
- Tag lines prior to removal to aid in installation.
- Discard packing(s) and lock washer(s).

REMOVE front loader/forklift hydraulic LINES and FITTINGS using illustration and legend as a guide.

FRONT LOADER/FORKLIFT HYDRAULIC LINES AND FITTINGS REPLACEMENT (CONT)

INSTALLATION

NOTE

- Procedure is the same for both vehicles.
- Install new packing(s) and new lock washer(s).

INSTALL front loader/forklift hydraulic LINES and FITTINGS using illustration and legend as a guide.

LEGEND

- 1 Tube assembly (2)
- 2 Tube assembly (2)
- 3 Nut (2)
- 4 Lock washer (2)
- 5 Clamp (4)
- 6 Screw (2)
- 7 Nut (2)
- 8 Bracket
- 9 Screw (2)
- 10 Elbow (4)
- 11 Nut (4)
- 12 Nipple (4)
- 13 Screw (2)
- 14 Lock washer (2)
- 15 Bracket
- 16 Packing (4)
- 17 Female quick disconnect (2)
- 18 Male quick disconnect (2)

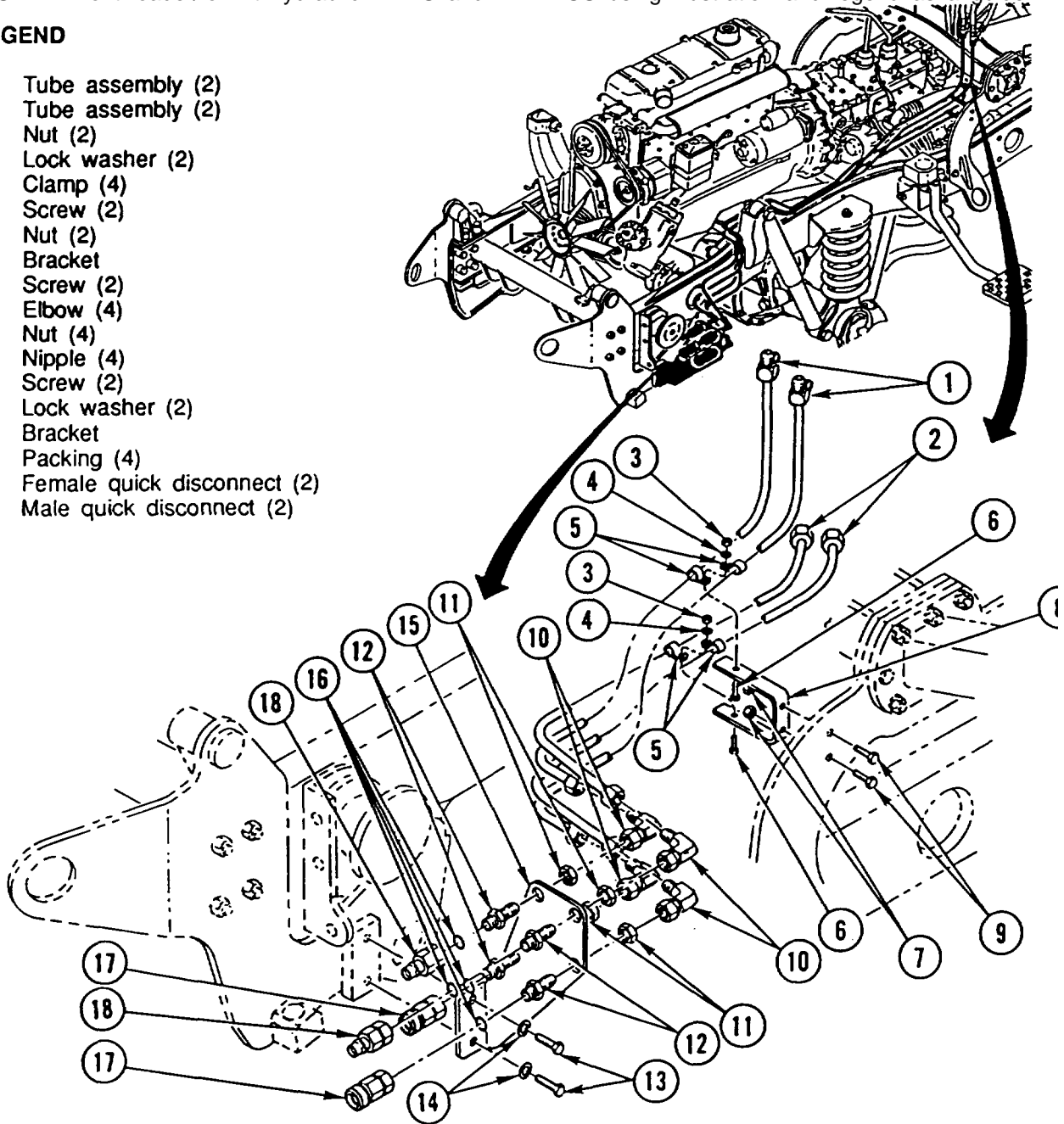

FRONT LOADER/FORKLIFT CONTROL VALVE HYDRAULIC LINES AND FITTINGS REPLACEMENT

This task covers: a. Removal b. Installation

INITIAL SETUP

Tools and Special Equipment:

Shop Equipment, SC 4910-95-CL-A74
Tool Kit, SC 5180-90-CL-N26

Materials/Parts:

Packing (AR)

Caps and Plugs Appendix C, Item 7

Rags Appendix C, Item 32

References:

TM 5-2420-224-10

Equipment Condition:

Reference	Condition Description
TM 5-2420-224-10	Loader Bucket (SEE) or Forklift (HMMH) Lowered to Ground
Page 2-23	Hydraulic Pressure Relieved

General Safety Instructions:

WARNING

- High pressure hydraulics [oil under 2450 psi (16,893 kPa)] operate this equipment. Never disconnect any hydraulic line or fitting without first dropping pressure to zero. A high pressure oil stream can pierce body and cause severe injury to personnel.
- Fuel and oil are slippery and can cause falls. To avoid injury, wipe up spilled fuel or oil with rags.

REMOVAL

CAUTION

Cap or plug all ports and ends of hoses and tubes to prevent contamination of hydraulic oil. Failure to do so may result in damage to equipment.

NOTE

- Procedure is the same for both vehicles.
- Tag lines prior to removal to aid in installation.
- Discard packing(s).

REMOVE front loader/forklift control valve hydraulic LINES and FITTINGS using illustration and legend as a guide.

FRONT LOADER/FORKLIFT CONTROL VALVE HYDRAULIC LINES AND FITTINGS REPLACEMENT (CONT)

INSTALLATION

NOTE

- Procedure is the same for both vehicles.
- Install new packing(s).

INSTALL front loader/forklift control valve hydraulic LINES and FITTINGS using illustration and legend as a guide.

LEGEND

- 1 Adapter (5)
- 2 Tee adapter
- 3 Elbow (5)
- 4 Elbow
- 5 Hose assembly (4)
- 6 Hose assembly (2)
- 7 Nipple (2)
- 8 Packing (6)

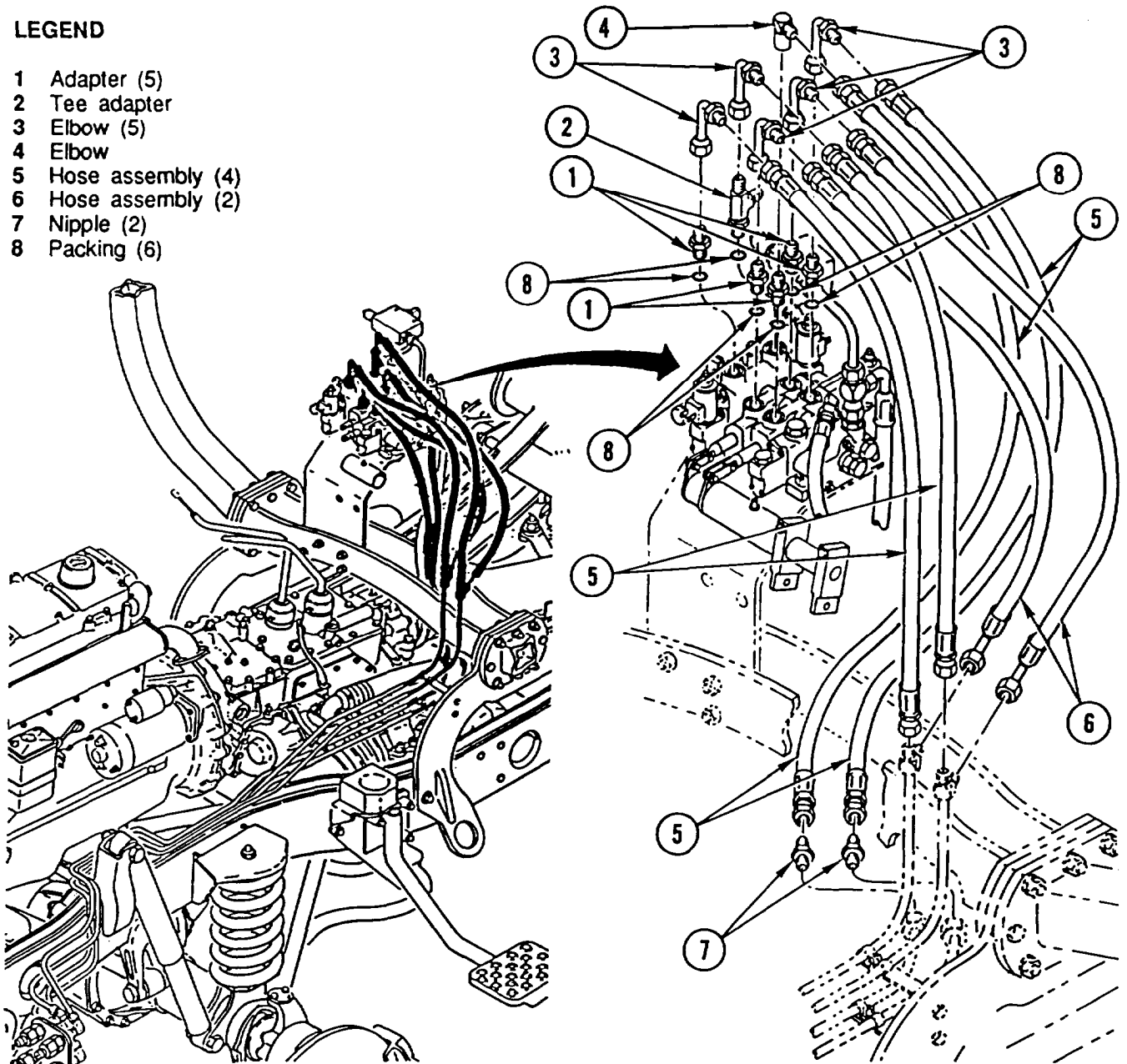

FRONT HYDRAULIC PUMP LINES AND FITTINGS REPLACEMENT

This task covers: a. Removal b. Installation

INITIAL SETUP

Tools and Special Equipment:

Shop Equipment, SC 4910-95-CL-A74
Tool Kit, SC 5180-90-CL-N26

Materials/Parts:

Packing (AR)

Caps and Plugs Appendix C, Item 7

Rags Appendix C, Item 32

References:

TM 5-2420-224-10

Equipment Condition:

Reference	Condition Description
TM 5-2420-224-10	Front Loader (SEE) or Forklift (HMMH) Lowered to Ground
Page 2-23	Hydraulic Pressure Relieved

General Safety Instructions:

WARNING

- High pressure hydraulics [oil under 2450 psi (16,893 kPa)] operate this equipment. Never disconnect any hydraulic line or fitting without first dropping pressure to zero. A high pressure oil stream can pierce body and cause severe injury to personnel.
- Fuel and oil are slippery and can cause falls. To avoid injury, wipe up spilled fuel or oil with rags.

REMOVAL

CAUTION

Cap or plug all ports and ends of hoses and tubes to prevent contamination of hydraulic oil. Failure to do so may result in damage to equipment.

NOTE

- Procedure is the same for both vehicles.
- Tag lines prior to removal to aid in installation.
- Discard packing(s).

REMOVE front hydraulic pump LINES and FITTINGS using illustration and legend as a guide.

FRONT HYDRAULIC PUMP LINES AND FITTINGS REPLACEMENT (CONT)

INSTALLATION

NOTE

- Procedure is the same for both vehicles.
- Install new packing(s).

INSTALL front hydraulic pump LINES and FITTINGS using illustration and legend as a guide.

LEGEND

- 1 Hose assembly
- 2 Elbow
- 3 Adapter
- 4 Packing
- 5 Screw
- 6 Clamp (3)
- 7 Washer (3)
- 8 Nut (3)
- 9 Hose assembly
- 10 Elbow
- 11 Coupling
- 12 Bracket (2)
- 13 Screw (2)
- 14 Screw (8)
- 15 Adapter
- 16 Packing
- 17 Packing
- 18 Adapter

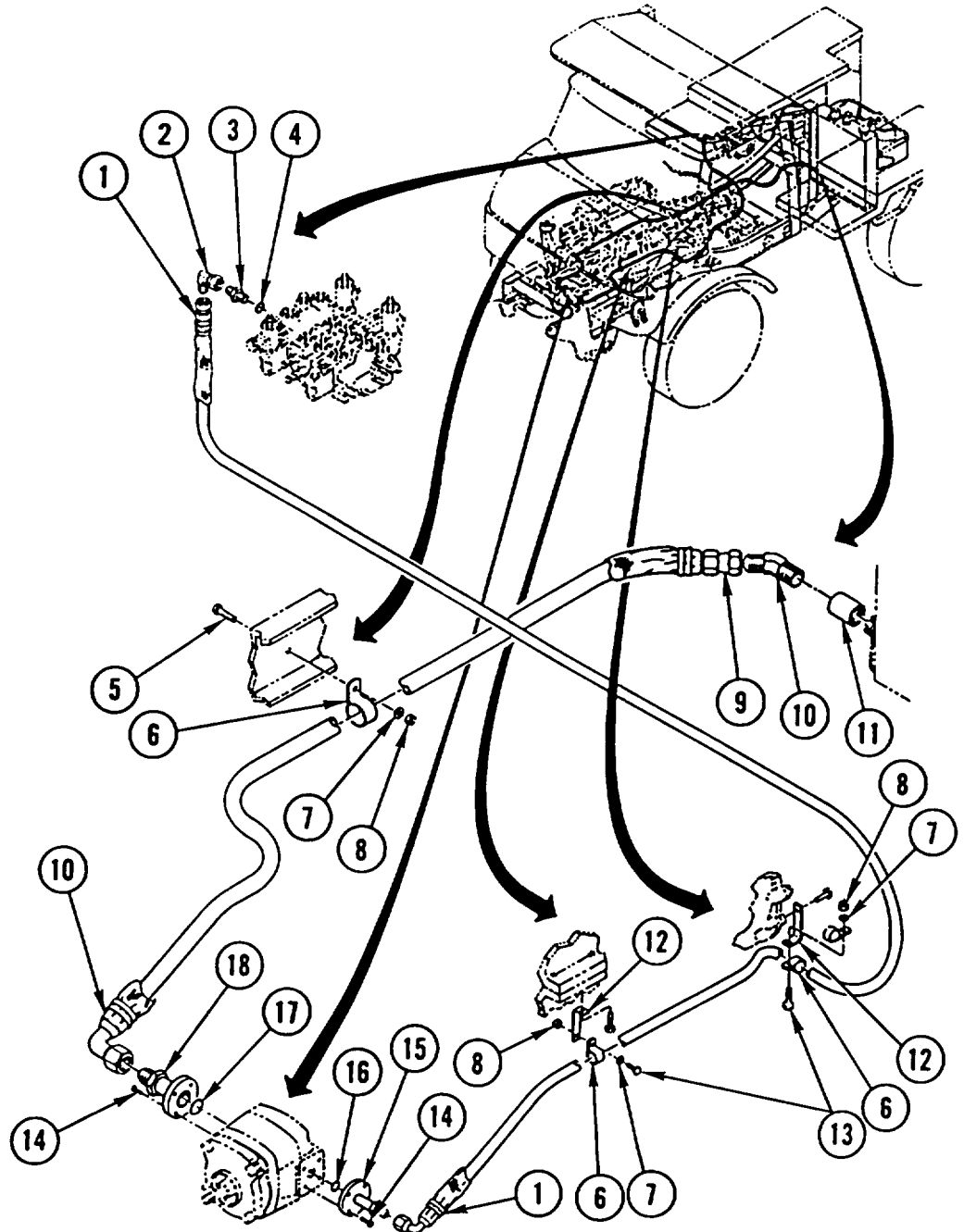

HAND TOOL HYDRAULIC LINES AND FITTINGS REPLACEMENT

This task covers: a. Removal b. Installation

INITIAL SETUP

Tools and Special Equipment:

Shop Equipment, SC 4910-95-CL-A74
Tool Kit," SC 5180-90-CL-N26

Materials/Parts:

Packing (AR)

Caps and Plugs Appendix C, Item 7

Rags Appendix C, Item 32

Equipment Condition:

Reference	Condition Description
Page 2-23	Hydraulic Pressure Relieved

General Safety Instructions:

WARNING

- High pressure hydraulics [oil under 2450 psi (16,893 kPa)] operate this equipment. Never disconnect any hydraulic line or fitting without first dropping pressure to zero. A high pressure oil stream can pierce body and cause severe injury to personnel.
- Fuel and oil are slippery and can cause falls. To avoid injury, wipe up spilled fuel or oil with rags.

REMOVAL

CAUTION

Cap or plug all ports and ends of hoses and tubes to prevent contamination of hydraulic oil. Failure to do so may result in damage to equipment.

NOTE

- Tag lines prior to removal to aid in installation.
- Discard packing(s).

REMOVE hand tool hydraulic LINES and FITTINGS using illustration and legend as a guide.

INSTALLATION

NOTE

Install new packing(s).

INSTALL hand tool hydraulic LINES and FITTINGS using illustration and legend as a guide.

HAND TOOL HYDRAULIC LINES AND FITTINGS REPLACEMENT (CONT)

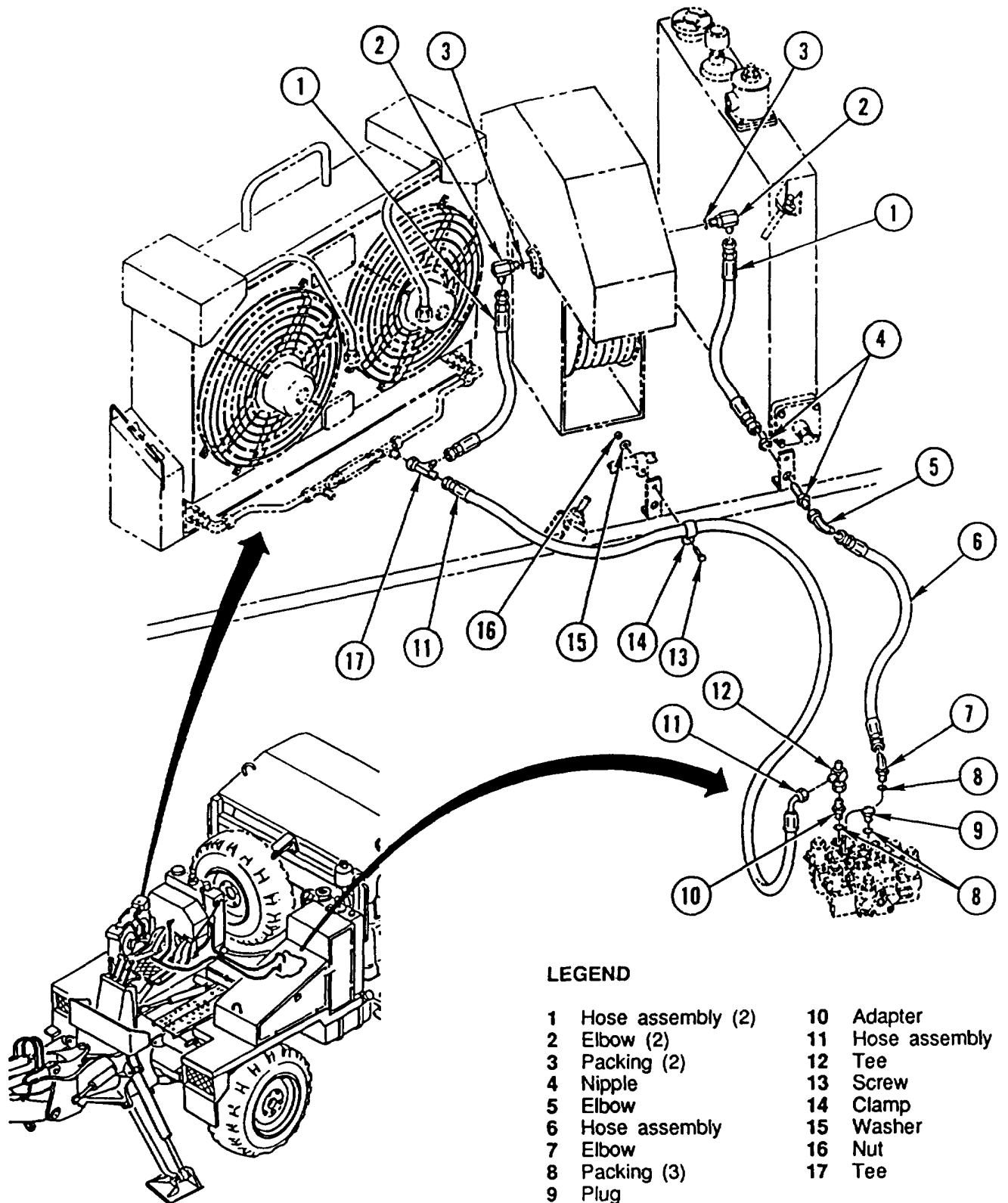

FRONT HYDRAULIC SYSTEM RETURN LINES AND FITTINGS REPLACEMENT

This task covers: a. Removal b. Installation

INITIAL SETUP

Tools and Special Equipment:

Shop Equipment, SC 4910-95-CL-A74
Tool Kit, SC 5180-90-CL-N26

Materials/Parts:

Packing (AR)

Caps and Plugs Appendix C, Item 7

Rags Appendix C, Item 32

References:

TM 5-2420-224-10

Equipment Condition:

Reference	Condition Description
TM 5-2420-224-10	Front Loader (SEE) or Forklift (HMMH) Lowered to Ground
Page 2-23	Hydraulic Pressure Relieved

General Safety Instructions:

WARNING

- High pressure hydraulics [oil under 2450 psi (16,893 kPa)] operate this equipment. Never disconnect any hydraulic line or fitting without first dropping pressure to zero. A high pressure oil stream can pierce body and cause severe injury to personnel.
- Fuel and oil are slippery and can cause falls. To avoid injury, wipe up spilled fuel or oil with rags.

REMOVAL

CAUTION

Cap or plug all ports and ends of hoses and tubes to prevent contamination of hydraulic oil. Failure to do so may result in damage to equipment.

NOTE

- Procedure is the same for both vehicles.
- Tag lines prior to removal to aid in installation.
- Discard packing(s).

REMOVE front hydraulic system return LINES and FITTINGS using illustration and legend as a guide.

FRONT HYDRAULIC SYSTEM RETURN LINES AND FITTINGS REPLACEMENT (CONT)

INSTALLATION

NOTE

- Procedure is the same for both vehicles.
- Install new packing(s).

INSTALL front hydraulic system return LINES and FITTINGS using illustration and legend as a guide.

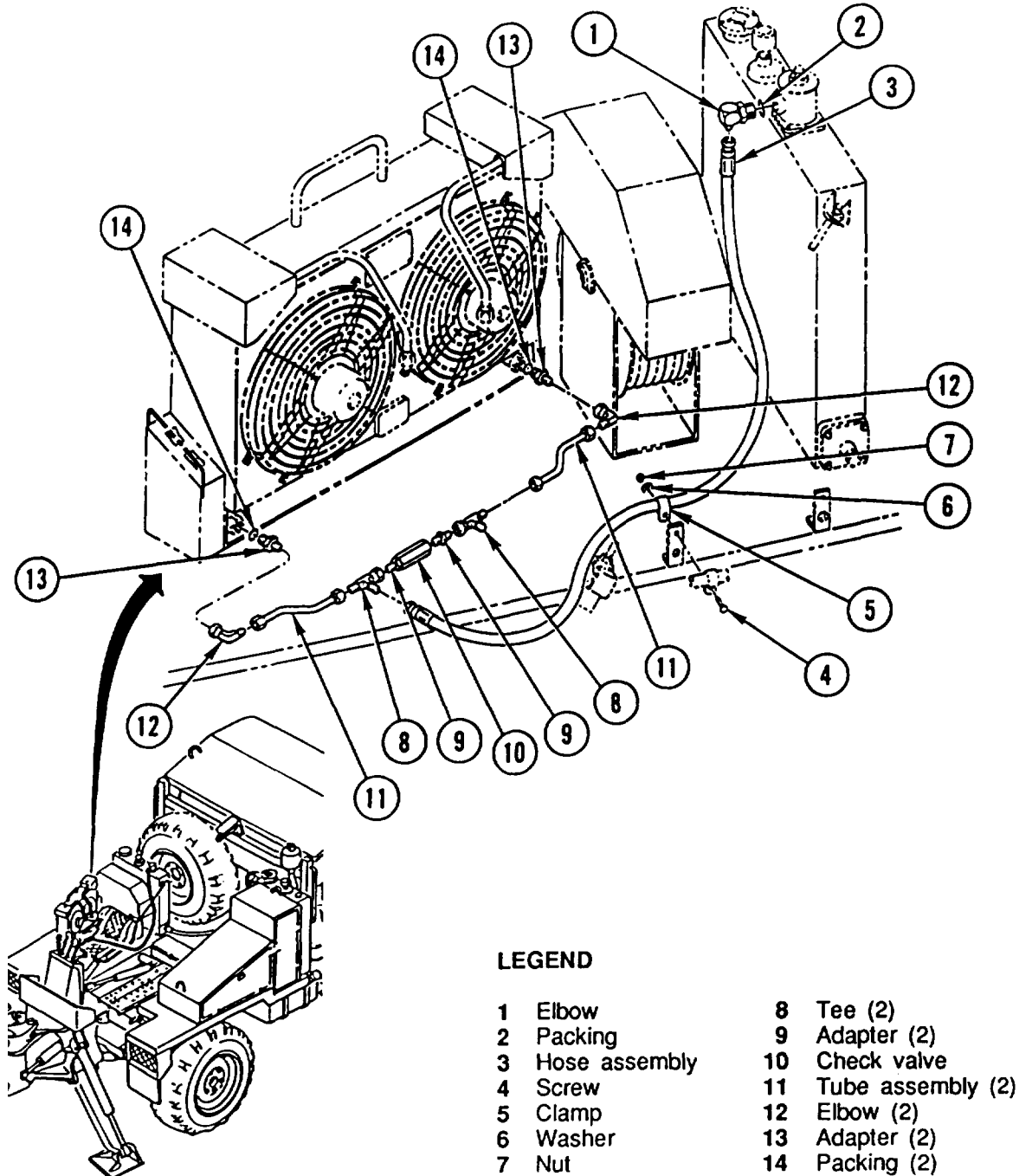

REAR HYDRAULIC PUMP LINES AND FITTINGS REPLACEMENT

This task covers: a. Removal b. Installation

INSTALLATION

Tools and Special Equipment:

Shop Equipment, SC 4910-95-CL-A74
Tool Kit, SC 5180-90-CL-N26

Materials/Parts:

Packing (AR)

Washer, Lock (AR)

Kit, Split Flange

Kit, Split Flange

Caps and Plugs Appendix C, Item 7

Rags Appendix C, Item 32

Equipment Condition:

Reference

Page 2-22 or 2-23

Condition Description

Backhoe (SEE) or Crane (HMMH) in Three-Point Stance

Page 2-23

Hydraulic Pressure Relieved

General Safety Instructions:

WARNING

- High pressure hydraulics [oil under 2450 psi (16,893 kPa)] operate this equipment. Never disconnect any hydraulic line or fitting without first dropping pressure to zero. A high pressure oil stream can pierce body and cause severe injury to personnel.
- Fuel and oil are slippery and can cause falls. To avoid injury, wipe up spilled fuel or oil with rags.

REMOVAL

CAUTION

Cap or plug all ports and ends of hoses and tubes to prevent contamination of hydraulic oil. Failure to do so may result in damage to equipment.

NOTE

- Procedure is the same for both vehicles.
- Tag lines prior to removal to aid in installation.
- Discard packing(s) and lock washer(s).

REMOVE rear hydraulic pump LINES and FITTINGS using illustration and legend as a guide.

REAR HYDRAULIC PUMP LINES AND FITTINGS REPLACEMENT (CONT)

INSTALLATION

NOTE

- Procedure is the same for both vehicles.
- Install new packing(s) and new lock washer(s).

INSTALL rear hydraulic pump LINES and FITTINGS using illustration and legend as a guide.

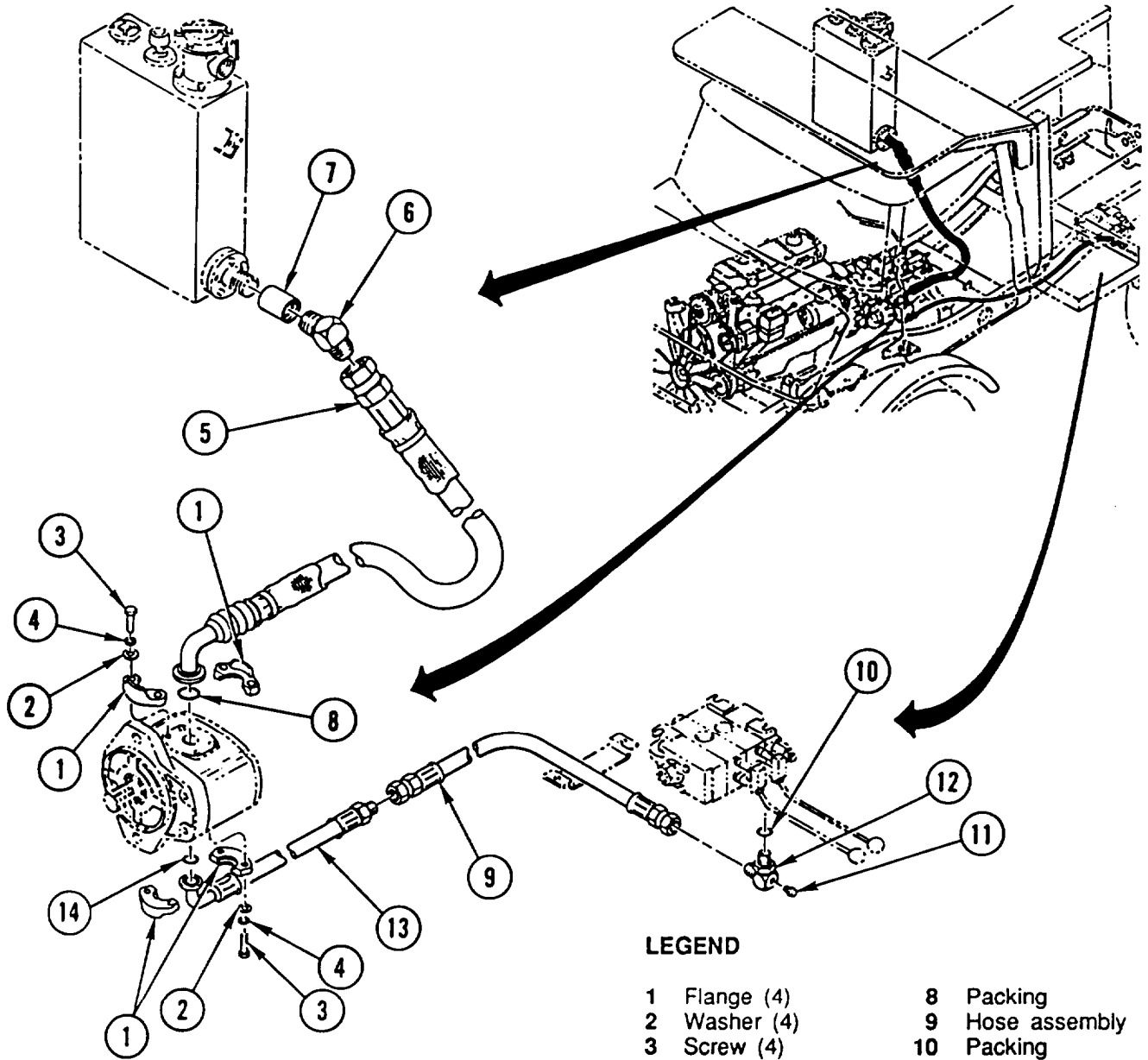

LEGEND

- | | |
|-------------------|------------------|
| 1 Flange (4) | 8 Packing |
| 2 Washer (4) | 9 Hose assembly |
| 3 Screw (4) | 10 Packing |
| 4 Lock washer (4) | 11 Nut |
| 5 Hose assembly | 12 Tee |
| 6 Elbow | 13 Hose assembly |
| 7 Coupling | 14 Packing |

REAR HYDRAULIC SYSTEM RETURN LINES AND FITTINGS REPLACEMENT

This task covers: a. Removal b. Installation

INITIAL SETUP

Tools and Special Equipment:

Shop Equipment, SC 4910-95-CL-A74
Tool Kit, SC 5180-90-CL-N26

Materials/Parts:

Packing (AR)
Nut, Lock (AR)
Kit, Split Flange
Kit, Split Flange
Caps and Plugs Appendix C, Item 7
Rags Appendix C, Item 32

Equipment Condition:

Reference	Condition Description
Page 2-22 or 2-23	Backhoe (SEE) or Crane (HMMH) in Three-Point Stance
Page 2-23	Hydraulic Pressure Relieved

General Safety Instructions:

WARNING

- High pressure hydraulics [oil under 2450 Psi (16,893 kPa)] operate this equipment; Never disconnect any hydraulic line or fitting without first dropping pressure to zero. A high pressure oil stream can pierce body and cause severe injury to personnel.
- Fuel and oil are slippery and can cause falls. To avoid injury, wipe up spilled fuel or oil with rags.

REMOVAL

CAUTION

Cap or plug all ports and ends of hoses and tubes to prevent contamination of hydraulic oil. Failure to do so may result in damage to equipment.

NOTE

- Procedure is the same for both vehicles.
- Tag lines prior to removal to aid in installation.
- Discard packing(s) and lock nut(s).

REMOVE rear hydraulic system return LINES and FITTINGS using illustration and legend as a guide.

REAR HYDRAULIC SYSTEM RETURN LINES AND FITTINGS REPLACEMENT (CONT)

INSTALLATION

NOTE

- Procedure is the same for both vehicles.
- Install new packing(s) and new lock nut(s).

INSTALL rear hydraulic system return LINES and FITTINGS using illustration and legend as a guide.

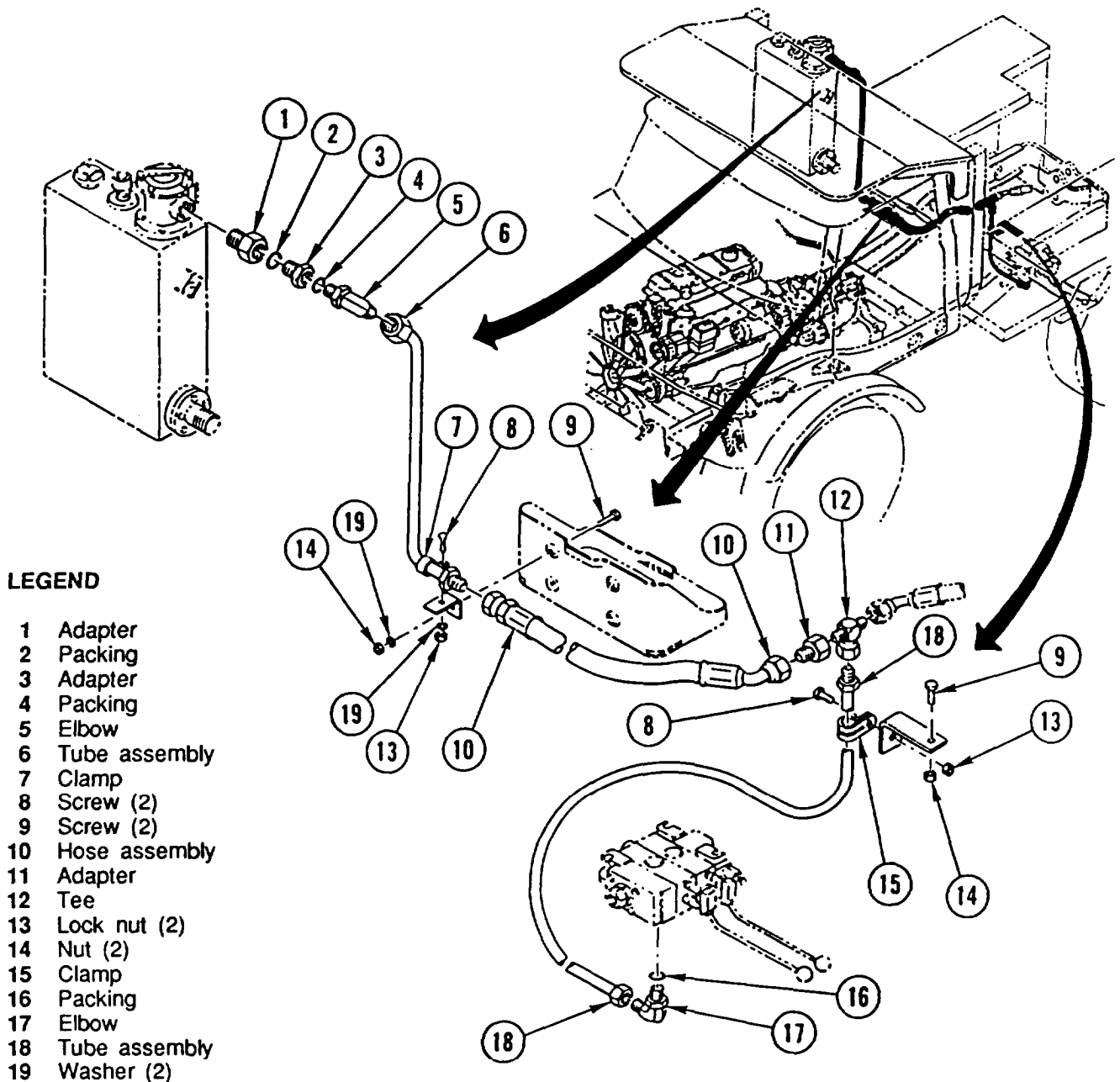

BACKHOE/CRANE TILT CYLINDER HYDRAULIC LINES AND FITTINGS REPLACEMENT

This task covers: a. Removal b. Installation

INITIAL SETUP

Tools and Special Equipment:

Shop Equipment, SC 4910-95-CL-A74
Tool Kit, SC 5180-90-CL-N26

Materials/Parts:

Packing (AR)

Nut, Lock (AR)

Caps and Plugs Appendix C, Item 7

Rags Appendix C, Item 32

Equipment Condition:

Reference

Page 2-22 or 2-23

Condition Description

Backhoe (SEE) or Crane (HMMH) in Three-Point Stance

Page 2-23

Hydraulic Pressure Relieved

General Safety Instructions:

WARNING

- High pressure hydraulics [oil under 2450 psi (16,893 kPa)] operate this equipment. Never disconnect any hydraulic line or fitting without first dropping pressure to zero. A high pressure oil stream can pierce body and cause severe injury to personnel.
- Fuel and oil are slippery and can cause falls. To avoid injury, wipe up spilled fuel or oil with rags.

REMOVAL

CAUTION

Cap or plug all ports and ends of hoses and tubes to prevent contamination of hydraulic oil. Failure to do so may result in damage to equipment.

NOTE

- Procedure is the same for both vehicles.
- Tag lines prior to removal to aid in installation.
- Discard packing(s) and lock nut.

REMOVE backhoe/crane tilt cylinder hydraulic LINES and FITTINGS using illustration and legend as a guide.

BACKHOE/CRANE TILT CYLINDER HYDRAULIC LINES AND FITTINGS REPLACEMENT (CONT)

INSTALLATION

NOTE

- Procedure is the same for both vehicles.
- Install new packing(s) and new lock nut.

INSTALL backhoe/crane tilt cylinder hydraulic LINES and FITTINGS using illustration and legend as a guide.

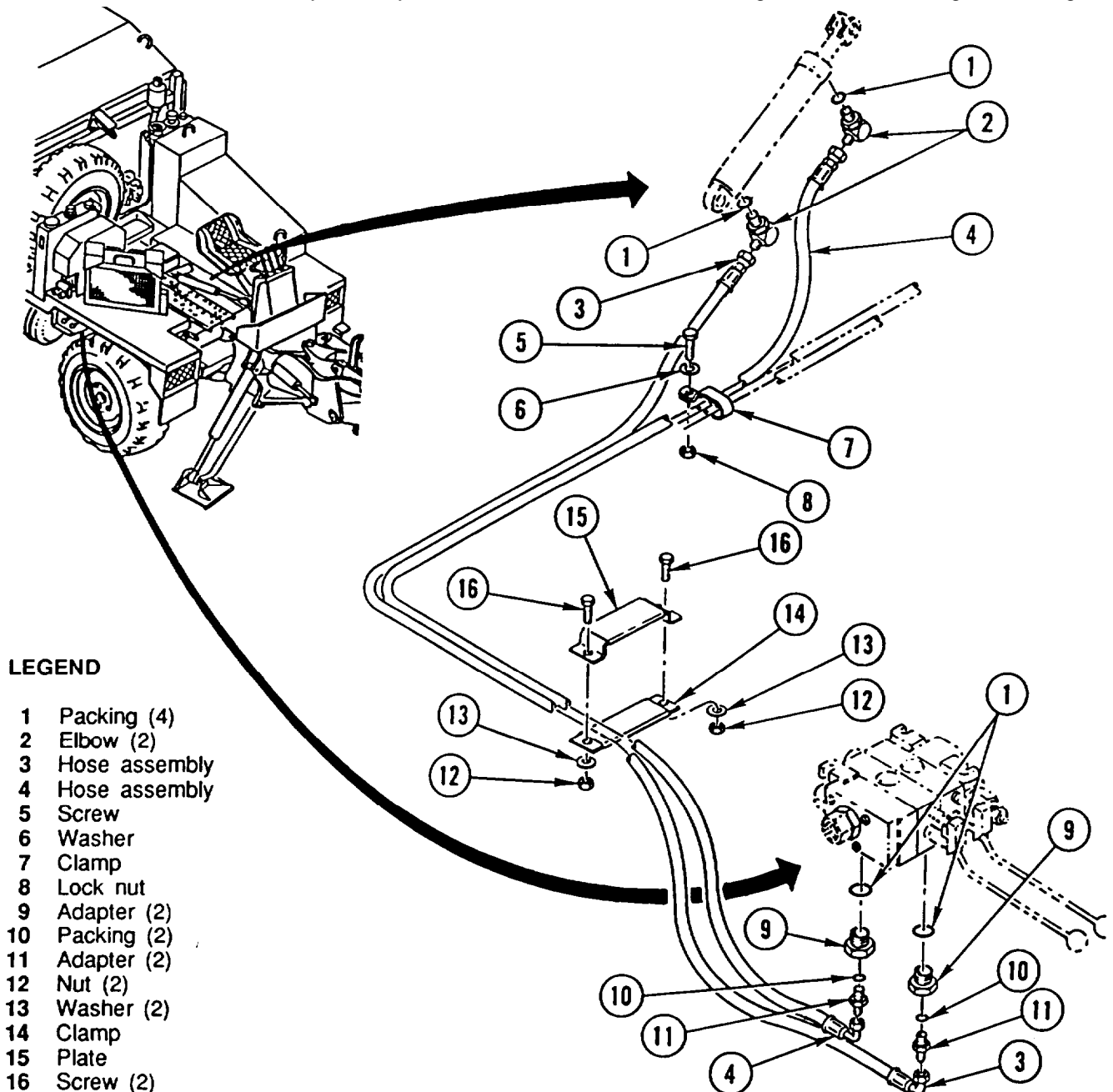

LEGEND

- 1 Packing (4)
- 2 Elbow (2)
- 3 Hose assembly
- 4 Hose assembly
- 5 Screw
- 6 Washer
- 7 Clamp
- 8 Lock nut
- 9 Adapter (2)
- 10 Packing (2)
- 11 Adapter (2)
- 12 Nut (2)
- 13 Washer (2)
- 14 Clamp
- 15 Plate
- 16 Screw (2)

BACKHOE/CRANE LATCH CYLINDER HYDRAULIC LINES AND FITTINGS REPLACEMENT

This task covers: a. Removal b. Installation

INITIAL SETUP

Tools and Special Equipment:

Shop Equipment, SC 4910-95-CL-A74
Tool Kit, SC 5180-90-CL-N26

Materials/Parts:

Packing (AR)

Nut, Lock (AR)

Caps and Plugs Appendix C, Item 7

Rags Appendix C, Item 32

Equipment Condition:

Reference	Condition	Description
Page 2-22 or 2-23	Backhoe (SEE) or Crane (HMMH) in Three-Point	

Page 2-23	Hydraulic Pressure Relieved	
-----------	-----------------------------	--

General Safety Instructions:

WARNING

High pressure hydraulics [oil under 2450 psi (16,893 kPa)] operate this equipment. Never disconnect any hydraulic line or fitting without first dropping pressure to zero. A high pressure oil stream can pierce body and cause severe injury to personnel.

Fuel and oil are slippery and can cause falls. To avoid injury, wipe up spilled fuel or oil with rags.

REMOVAL

CAUTION

Cap or plug all ports and ends of hoses and tubes to prevent contamination of hydraulic oil. Failure to do so may result in damage to equipment.

NOTE

- Procedure is the same for both vehicles.
- Tag lines and fittings prior to removal to aid in installation.
- Discard packing(s) and lock nut.

REMOVE backhoe/crane latch cylinder hydraulic LINES and FITTINGS using illustration and legend as a guide.

INSTALLATION

NOTE

- Procedure is the same for both vehicles.
- Install new packing(s) and new lock nut.

INSTALL backhoe/crane latch cylinder hydraulic LINES and FITTINGS using illustration and legend as a guide.

BACKHOE/CRANE LATCH CYLINDER HYDRAULIC LINES AND FITTINGS REPLACEMENT (CONT)

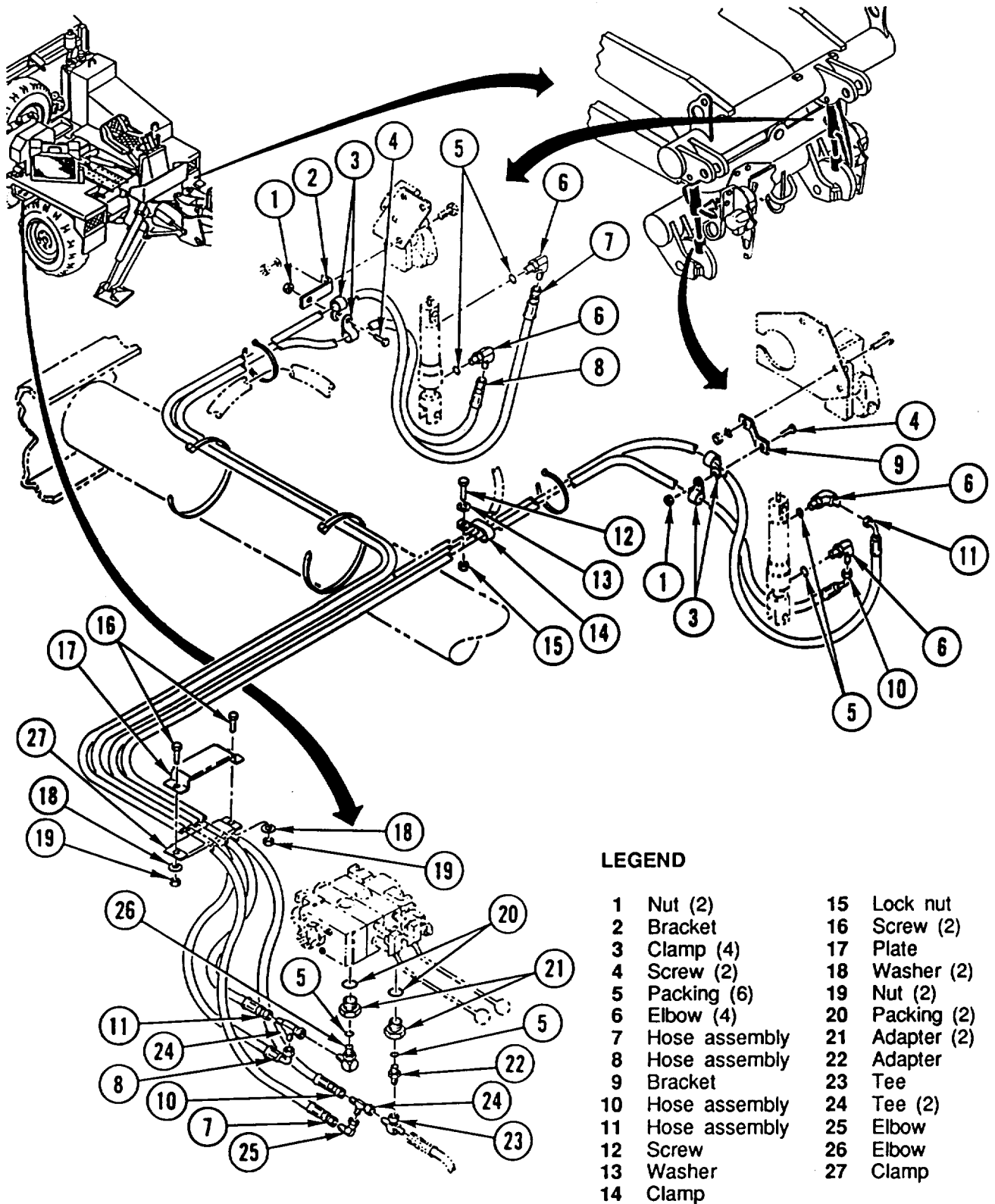

BACKHOE/CRANE HYDRAULIC LINES AND FITTINGS REPLACEMENT -

This task covers: a. Removal b. Installation

INITIAL SETUP

Tools and Special Equipment:

Shop Equipment, SC 4910-95-CL-A74
Tool Kit, SC 5180-90-CL-N26

General Safety Instructions:

Materials/Parts:

Packing (AR)
Nut, Lock (AR)
Caps and Plugs Appendix C, Item 7
Rags Appendix C, Item 32

Equipment Condition:

Reference	Condition Description
Page 2-22 or 2-23	Backhoe (SEE) or Crane (HMMH) in Three-Point Stance
Page 2-23	Hydraulic Pressure Relieved

WARNING

High pressure hydraulics [oil under 2450 psi (16,893 kPa)] operate this equipment. Never disconnect any hydraulic line or fitting without first dropping pressure to zero. A high pressure oil stream can pierce body and cause severe injury to personnel.

Fuel and oil are slippery and can cause falls. To avoid injury, wipe up spilled fuel or oil with rags.

REMOVAL

CAUTION

Cap or plug all ports and ends of hoses and tubes to prevent contamination of hydraulic oil. Failure to do so may result in damage to equipment.

NOTE

- Procedure is the same for both vehicles.
- Tag lines prior to removal to aid in installation.
- Discard packing(s) and lock nut.

REMOVE backhoe/crane hydraulic LINES and FITTINGS using illustration and legend as a guide.

INSTALLATION

NOTE

- Procedure is the same for both vehicles.
- Install new packing(s) and new lock nut.

INSTALL backhoe/crane hydraulic LINES and FITTINGS using illustration and legend as a guide.

**BACKHOE/CRANE HYDRAULIC LINES AND FITTINGS REPLACEMENT
(CONT)**

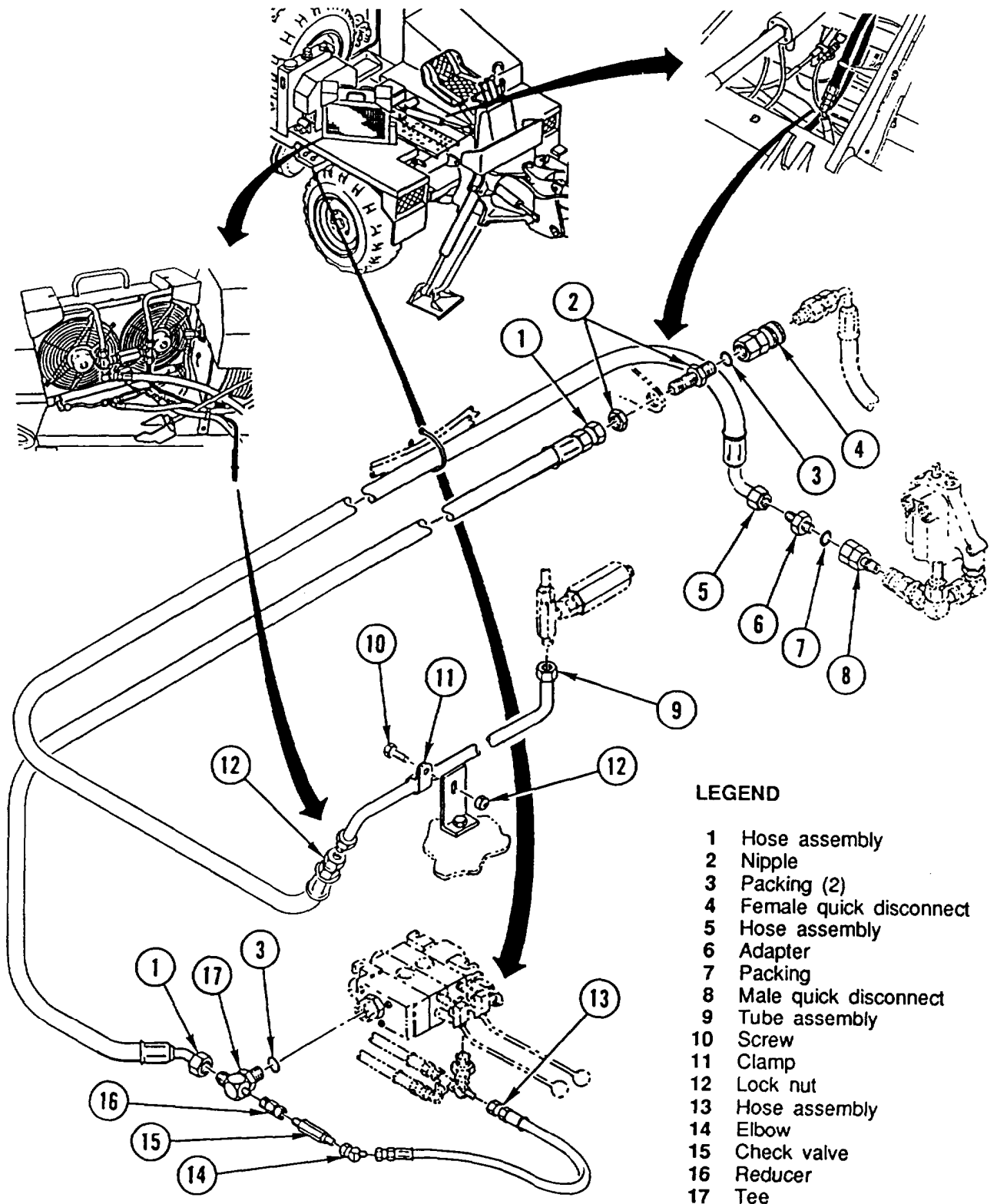

LEGEND

- 1 Hose assembly
- 2 Nipple
- 3 Packing (2)
- 4 Female quick disconnect
- 5 Hose assembly
- 6 Adapter
- 7 Packing
- 8 Male quick disconnect
- 9 Tube assembly
- 10 Screw
- 11 Clamp
- 12 Lock nut
- 13 Hose assembly
- 14 Elbow
- 15 Check valve
- 16 Reducer
- 17 Tee

RIGHT BACKHOE STABILIZER CYLINDER HYDRAULIC LINES AND FITTINGS REPLACEMENT

This task covers: a. Removal b. Installation

INITIAL SETUP

Applicable Configuration:

SEE

Tools and Special Equipment:

Shop Equipment, SC 4910-95-CL-A74
Tool Kit, SC 5180-90-CL-N26

Materials/Parts:

Packing (AR)

Caps and Plugs Appendix C, Item 7

Rags Appendix C, Item 32

Equipment Condition:

Reference	Condition Description
Page 2-22	Backhoe in Three-Point Stance
Page 2-23	Hydraulic Pressure Relieved

General Safety instructions:

WARNING

High pressure hydraulics [oil under 2450 psi (16,893 kPa)] operate this equipment. Never disconnect any hydraulic line or fitting without first dropping pressure to zero. A high pressure oil stream can pierce body and cause severe injury to personnel.

Fuel and oil are slippery and can cause falls. To avoid injury, wipe up spilled fuel or oil with rags.

REMOVAL

CAUTION

Cap or plug all ports and ends of hoses and tubes to prevent contamination of hydraulic oil. Failure to do so may result in damage to equipment.

NOTE

- Tag lines prior to removal to aid in installation.
- Discard packing(s).

REMOVE right backhoe stabilizer cylinder hydraulic LINES and FITTINGS using illustration and legend as a guide.

INSTALLATION

NOTE

Install new packing(s).

INSTALL right backhoe stabilizer cylinder hydraulic LINES and FITTINGS using illustration and legend as a guide.

RIGHT BACKHOE STABILIZER CYLINDER HYDRAULIC LINES AND FITTINGS REPLACEMENT (CONT)

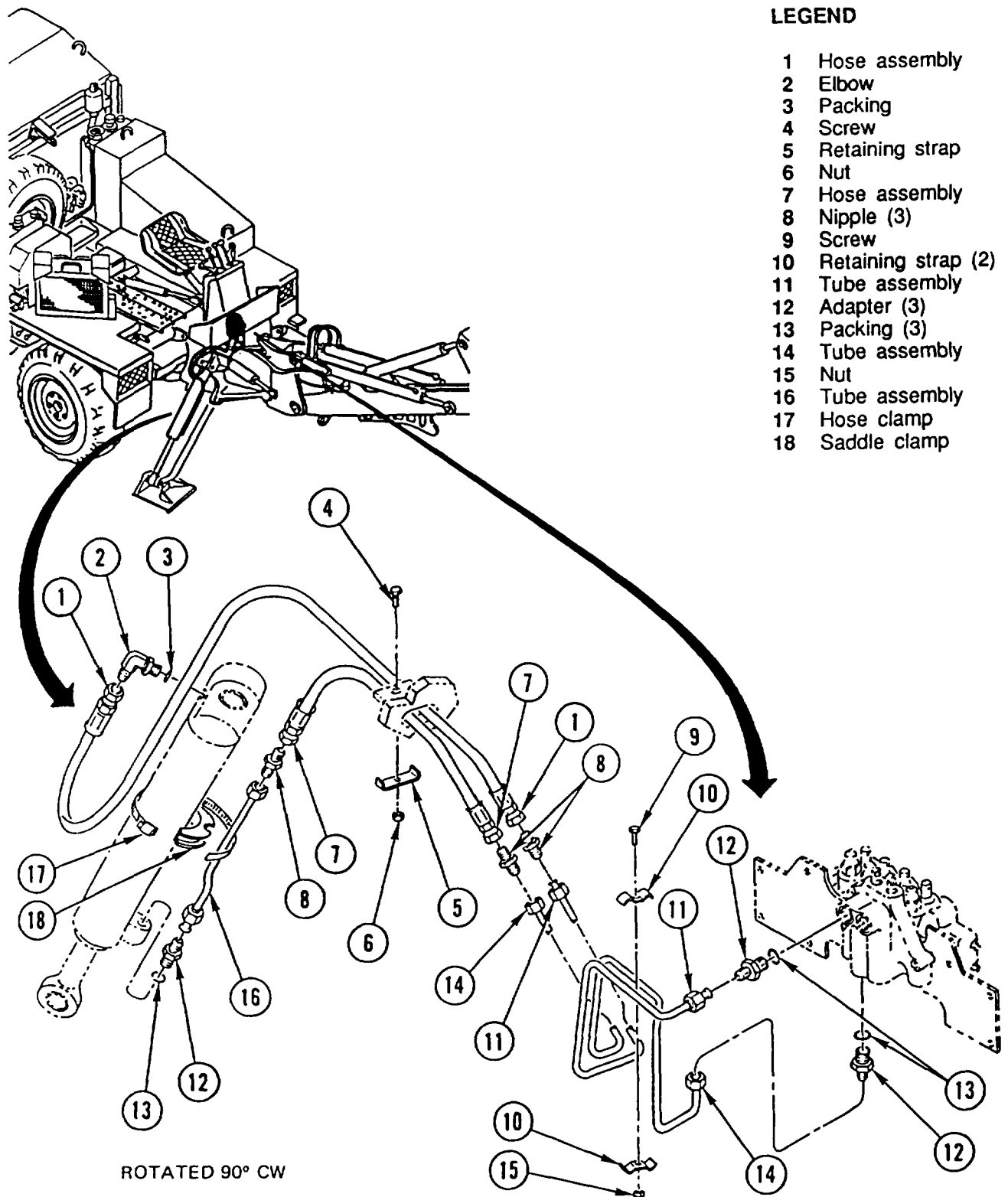

LEFT BACKHOE STABILIZER CYLINDER HYDRAULIC LINES AND FITTINGS REPLACEMENT

This task covers: a. Removal b. Installation

INITIAL SETUP

Applicable Configuration:

SEE

Tools and Special Equipment:

Shop Equipment, SC 4910-95-CL-A74
Tool Kit, SC 5180-90-CL-N26

Materials/Parts:

Packing (AR)

Caps and Plugs Appendix C, Item 7

Rags Appendix C, Item 32

Equipment Condition:

Reference

Page 2-22

Page 2-23

Condition Description

Backhoe in Three-Point Stance

Hydraulic Pressure Relieved

General Safety Instructions:

WARNING

- High pressure hydraulics [oil under 2450 psi (16,893 kPa)] operate this equipment. Never disconnect any hydraulic line or fitting without first dropping pressure to zero. A high pressure oil stream can pierce body and cause severe injury to personnel.
- Fuel and oil -are slippery and can cause falls. To avoid injury, wipe up spilled fuel or oil with rags.

REMOVAL

CAUTION

Cap or plug all ports and ends of hoses and tubes to prevent contamination of hydraulic oil. Failure to do so may result in damage to equipment.

NOTE

- Tag lines prior to removal to aid in installation.
- Discard packing(s).

REMOVE left backhoe stabilizer cylinder hydraulic LINES and FITTINGS using illustration and legend as a guide.

INSTALLATION

NOTE

Install new packing(s).

INSTALL left backhoe stabilizer cylinder hydraulic LINES and FITTINGS using illustration and legend as a guide.

LEFT BACKHOE STABILIZER CYLINDER HYDRAULIC LINES AND FITTINGS REPLACEMENT (CONT)

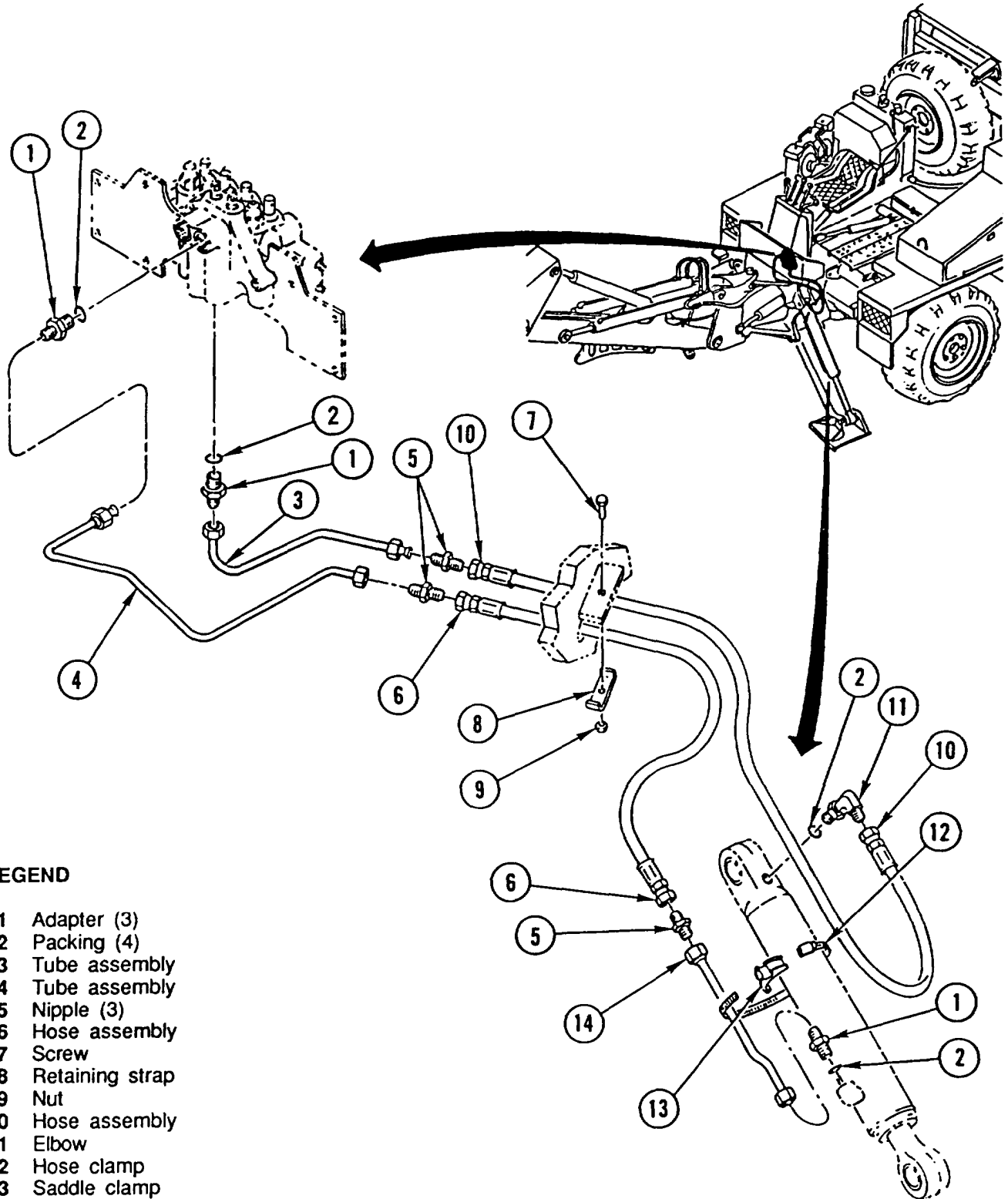

LEGEND

- 1 Adapter (3)
- 2 Packing (4)
- 3 Tube assembly
- 4 Tube assembly
- 5 Nipple (3)
- 6 Hose assembly
- 7 Screw
- 8 Retaining strap
- 9 Nut
- 10 Hose assembly
- 11 Elbow
- 12 Hose clamp
- 13 Saddle clamp
- 14 Tube assembly

BACKHOE STABILIZER CONTROL VALVE HYDRAULIC LINES AND FITTINGS REPLACEMENT

This task covers: a. Removal b. Installation

INITIAL SETUP

Applicable Configuration:

SEE

Tools and Special Equipment:

Shop Equipment, SC 4910-95-CL-A74
Tool Kit, SC 5180-90-CL-N26

Materials/Parts:

Packing (AR)

Caps and Plugs Appendix C, item 7

Rags Appendix C, item 32

Equipment Condition:

Reference

Page 2-22

Condition Description

Backhoe in Three-Point Stance

Page 2-23

Hydraulic Pressure Relieved

General Safety Instructions:

WARNING

- High pressure hydraulics [oil under 2450 psi (16,893 kPa)] operate this equipment. Never disconnect any hydraulic line or fitting without first dropping pressure to zero. A high pressure oil stream can pierce body and cause severe injury to personnel.
- Fuel and oil are slippery and can cause falls. To avoid injury, wipe up spilled fuel or oil with rags.

REMOVAL

CAUTION

Cap or plug all ports and ends of hoses and tubes to prevent contamination of hydraulic oil. Failure to do so may result in damage to equipment.

NOTE

- Tag lines prior to removal to aid in installation.
- Discard packing(s).

REMOVE backhoe stabilizer control valve hydraulic LINES and FITTINGS using illustration and legend as a guide.

INSTALLATION

NOTE

Install new packing(s).

INSTALL backhoe stabilizer control valve hydraulic LINES and FITTINGS using illustration and legend as a guide.

BACKHOE STABILIZER CONTROL VALVE HYDRAULIC LINES AND FITTINGS REPLACEMENT (CONT)

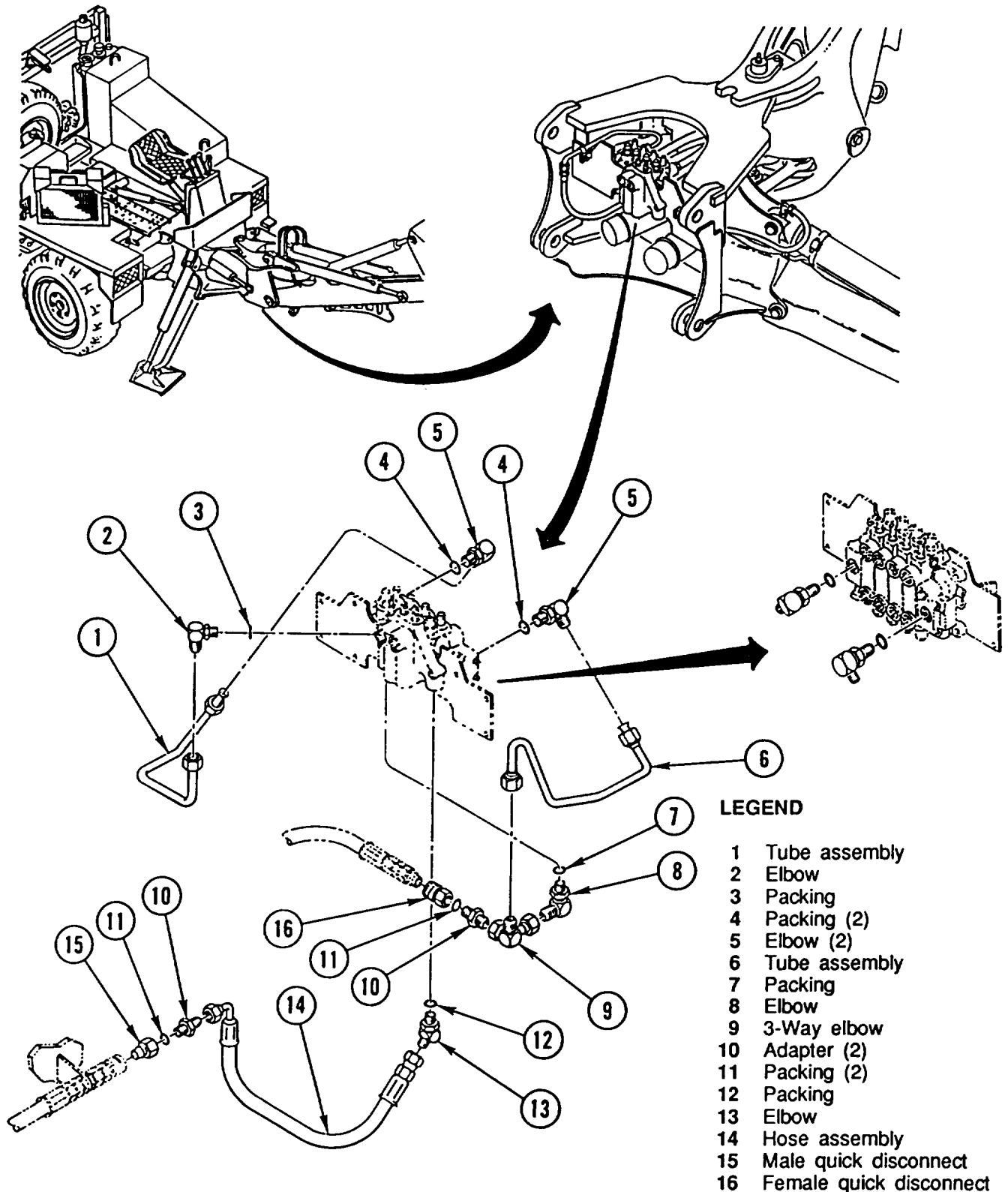

BACKHOE SWING CYLINDER HYDRAULIC LINES AND FITTINGS REPLACEMENT

This task covers: a. Removal b. Installation

INITIAL SETUP

Applicable Configuration:

SEE

Tools and Special Equipment:

Shop Equipment, SC 4910-95-CL-A74
Tool Kit, SC 5180-90-CL-N26

Materials/Parts:

Packing (AR)

Caps and Plugs Appendix C, item 7

Rags Appendix C, Item 32

Equipment Condition:

Reference

Page 2-22

Condition Description

Backhoe in Three-Point Stance

Page 2-23

Hydraulic Pressure Relieved

General Safety Instructions:

WARNING

- High pressure hydraulics [oil under 2450 psi (16,893 kPa)] operate this equipment. Never disconnect any hydraulic line or fitting without first dropping pressure to zero. A high pressure oil stream can pierce body and cause severe injury to personnel.
- Fuel and oil are slippery and can cause falls. To avoid injury, wipe up spilled fuel or oil with rags.

REMOVAL

CAUTION

Cap or plug all ports and ends of hoses and tubes to prevent contamination of hydraulic oil. Failure to do so may result in damage to equipment.

NOTE

- Tag lines prior to removal to aid in installation.
- Discard packing(s).

REMOVE backhoe swing cylinder hydraulic LINES and FITTINGS using illustration and legend as a guide.

INSTALLATION

NOTE

Install new packing(s).

INSTALL backhoe swing cylinder hydraulic LINES and FITTINGS using illustration and legend as a guide.

**BACKHOE SWING CYLINDER HYDRAULIC LINES AND FITTINGS
REPLACEMENT (CONT)**

LEGEND

- 1 Hose assembly (2)
- 2 Hose assembly (2)
- 3 Packing (4)
- 4 Elbow (2)
- 5 Packing (2)

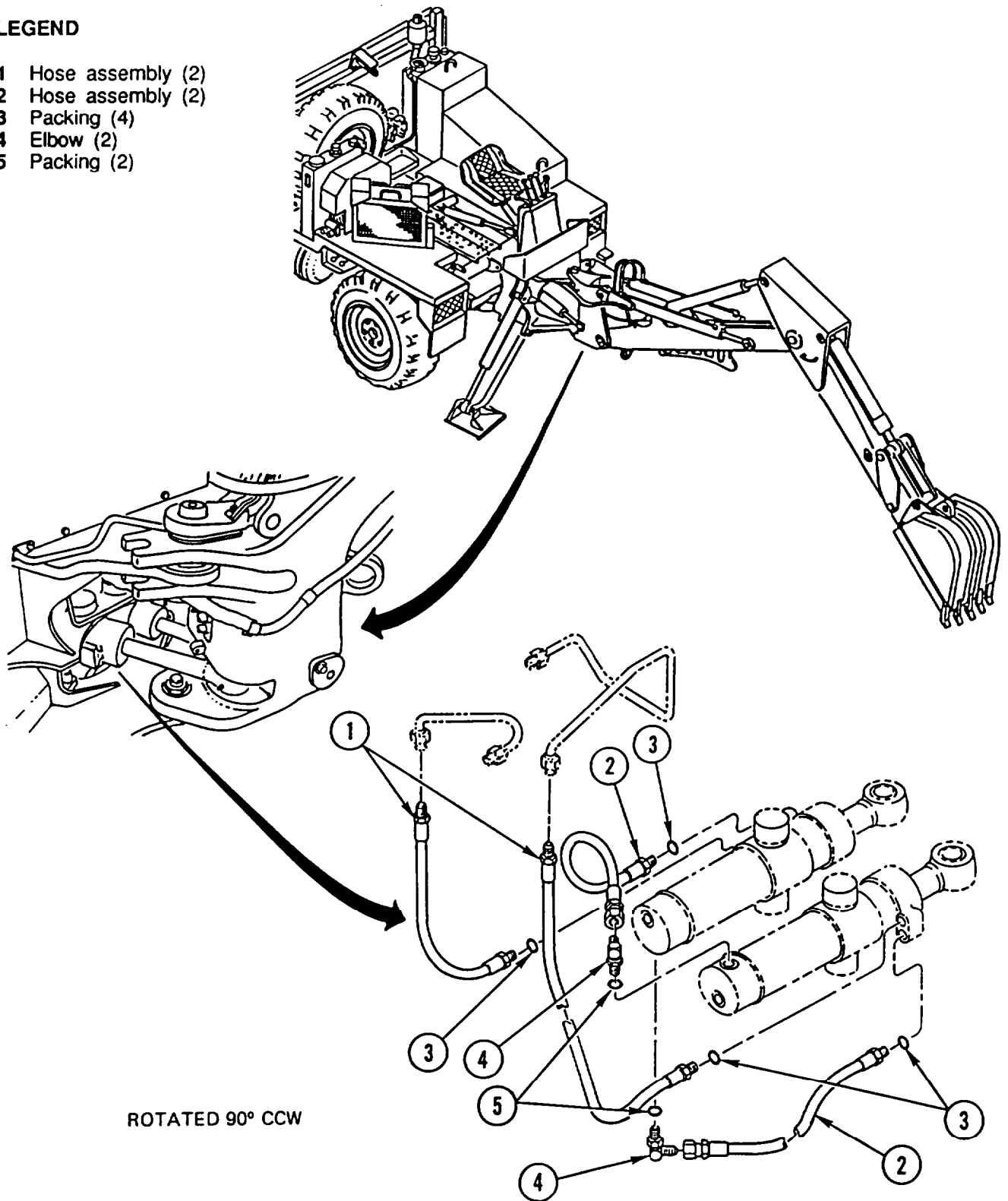

ROTATED 90° CCW

BACKHOE CONTROL VALVE, SWING SECTION HYDRAULIC LINES AND FITTINGS REPLACEMENT

This task covers: a. Removal b. Installation

INITIAL SETUP

Applicable Configuration:

SEE

Tools and Special Equipment:

Shop Equipment, SC 4910-95-CL-A74
Tool Kit, SC 5180-90-CL-N26

Materials/Parts:

Packing (AR)

Caps and Plugs Appendix C, item 7

Rags Appendix C, Item 32

Equipment Condition:

Reference	Condition	Description
Page 2-22	Backhoe in Three-Point Stance	
Page 2-23	Hydraulic Pressure Relieved	

General Safety Instructions:

WARNING

- High pressure hydraulics [oil under 2450 psi (16,893 kPa)] operate this equipment. Never disconnect any hydraulic line or fitting without first dropping pressure to zero. A high pressure oil stream can pierce body and cause severe injury to personnel.
- Fuel and oil are slippery and can cause falls. To avoid injury, wipe up spilled fuel or oil with rags.

REMOVAL

CAUTION

Cap or plug all ports and ends of hoses and tubes to prevent contamination of hydraulic oil. Failure to do so may result in damage to equipment.

NOTE

- Tag lines prior to removal to aid in installation.
- Discard packing(s).

REMOVE backhoe control valve, swing section hydraulic LINES and FITTINGS using illustration and legend as a guide.

INSTALLATION

NOTE

Install new packing(s).

INSTALL backhoe control valve, swing section hydraulic LINES and FITTINGS using illustration and legend as a guide.

BACKHOE CONTROL VALVE, SWING SECTION HYDRAULIC LINES AND FITTINGS REPLACEMENT (CONT)

LEGEND

- | | |
|-----------------|-----------------------|
| 1 Nut (2) | 7 Retaining strap (2) |
| 2 Washer (2) | 8 Spacer |
| 3 Clamp (2) | 9 Packing (2) |
| 4 Tube assembly | 10 Adapter (2) |
| 5 Screw (2) | 11 Tube assembly |
| 6 Nut | 12 Screw |

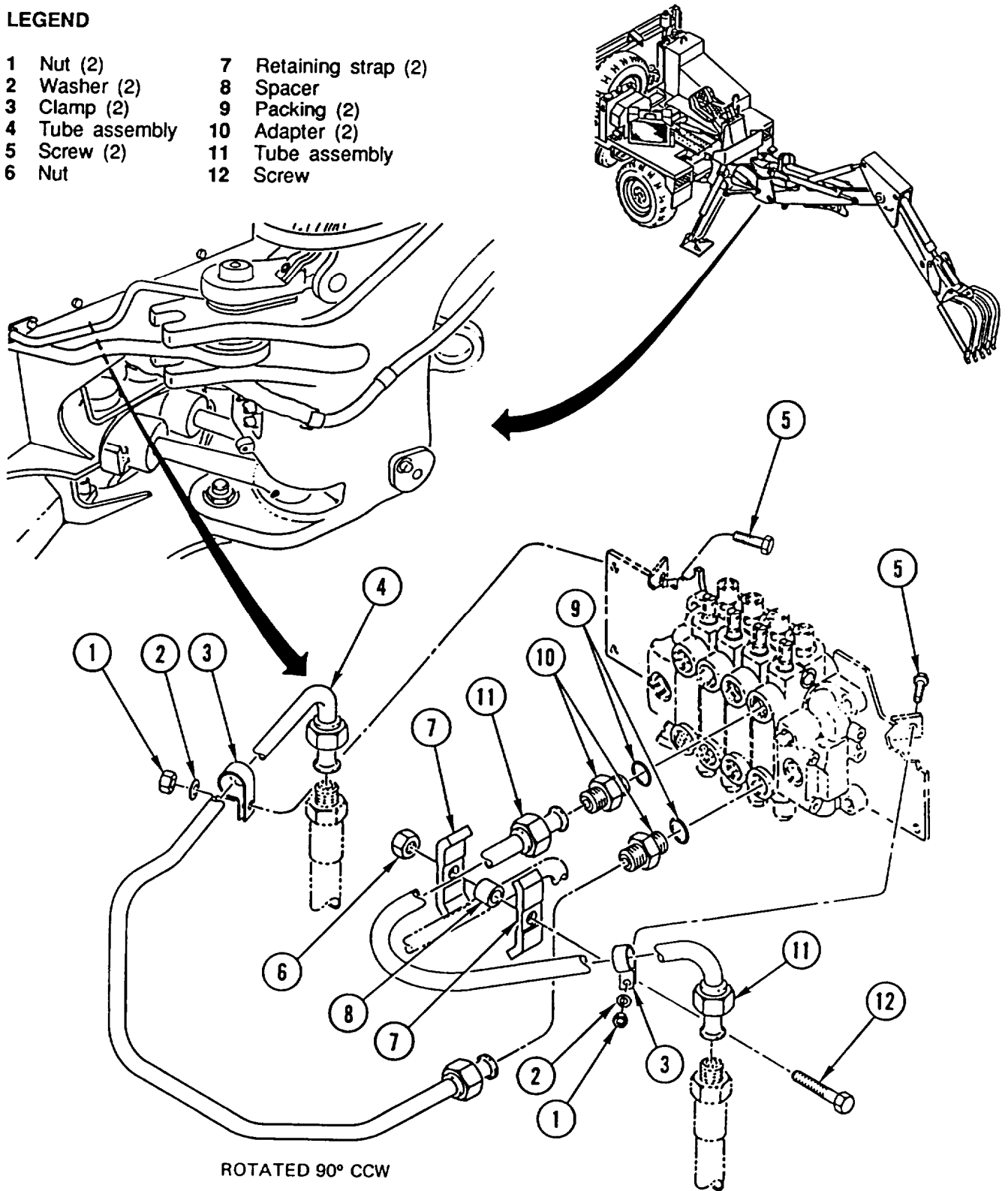

BACKHOE BOOM CYLINDER HYDRAULIC LINES AND FITTINGS REPLACEMENT

This task covers: a. Removal b. Installation

INITIAL SETUP

Applicable Configuration:

SEE

Tools and Special Equipment:

Shop Equipment, SC 4910-95-CL-A74
Tool Kit, SC 5180-90-CL-N26

Materials/Parts:

Washer, Lock (AR)

Packing (AR)

Caps and Plugs Appendix C, Item 7

Rags Appendix C, Item 32

Equipment condition:

Reference	Condition Description
Page 2-22	Backhoe in Three-Point Stance
Page 2-23	Hydraulic Pressure Relieved

General Safety Instructions:

WARNING

- High pressure hydraulics [oil under 2450 psi (16,893 kPa)] operate this equipment. Never disconnect any hydraulic line or fitting without first dropping pressure to zero. A high pressure oil stream can pierce body and cause severe injury to personnel.
- Fuel and oil are slippery and can cause falls. To avoid injury, wipe up spilled fuel or oil with rags.

REMOVAL

CAUTION

Cap or plug all ports and ends of hoses and tubes to prevent contamination of hydraulic oil. Failure to do so may result in damage to equipment.

NOTE

- Tag lines prior to removal to aid in installation.
- Discard lock washer and packing(s).

REMOVE backhoe boom cylinder hydraulic LINES and FITTINGS using illustration and legend as a guide.

INSTALLATION

NOTE

Install new lock washer and new packing(s).

INSTALL backhoe boom cylinder hydraulic LINES and FITTINGS using illustration and legend as a guide.

BACKHOE BOOM CYLINDER HYDRAULIC LINES AND FITTINGS REPLACEMENT (CONT)

LEGEND

- | | |
|-----------------|-------------------|
| 1 Hose assembly | 11 Screw |
| 2 Hose assembly | 12 Tube assembly |
| 3 Nut | 13 Tee |
| 4 Lock washer | 14 Tube assembly |
| 5 Clamp (2) | 15 Tube assembly |
| 6 Spacer | 16 Hose clamp (2) |
| 7 Tube assembly | 17 Clamp (2) |
| 8 Packing (2) | 18 Packing (2) |
| 9 Adapter (2) | 19 Tee |
| 10 Tube | |

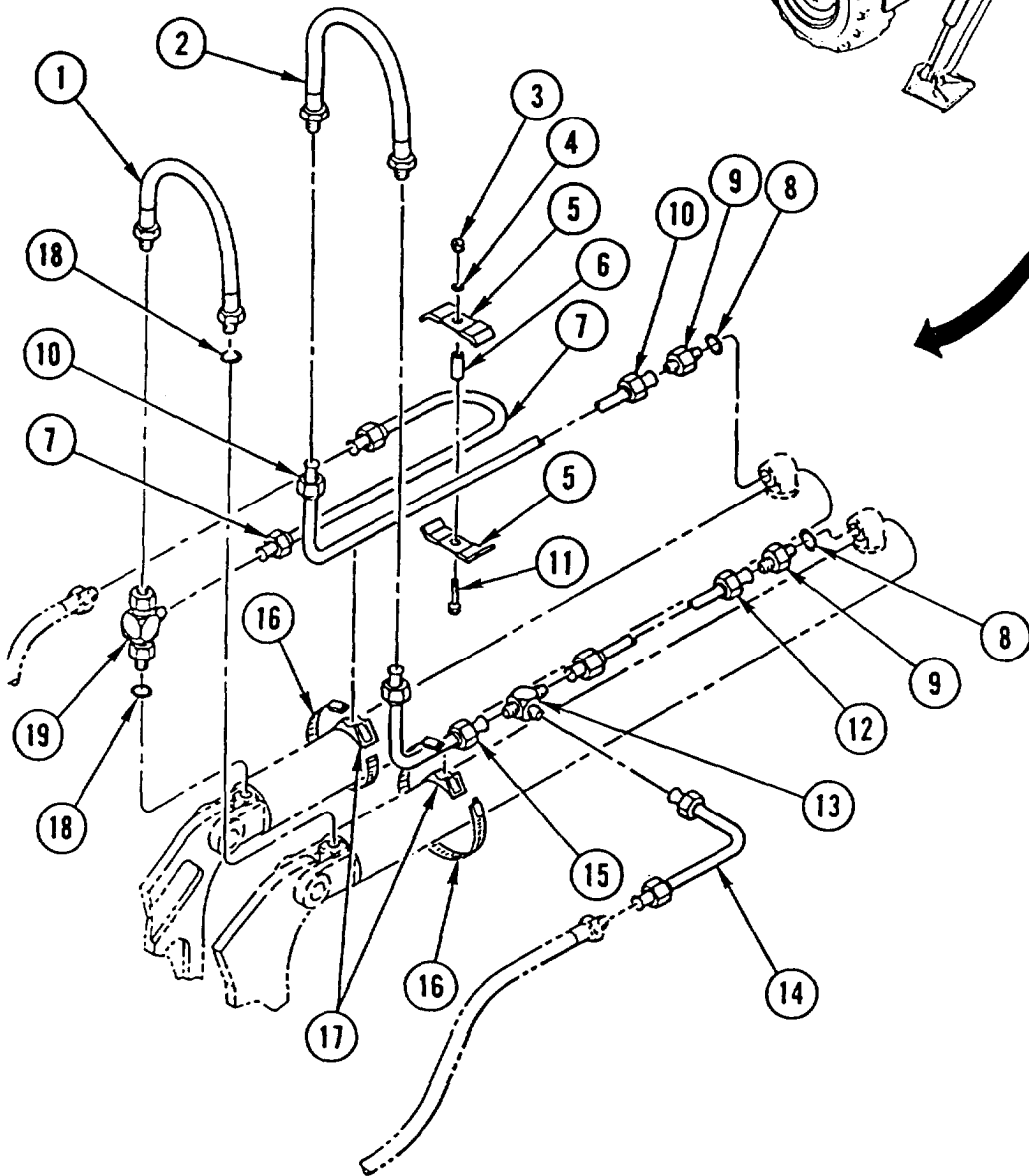
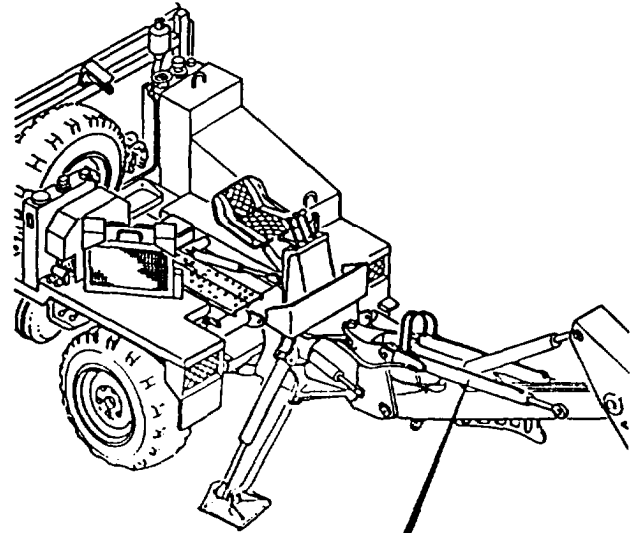

BACKHOE CONTROL VALVE, BOOM SECTION HYDRAULIC LINES AND FITTINGS REPLACEMENT

This task covers: a. Removal b. Installation

INITIAL SETUP

Applicable Configuration:

SEE

Tools and Special Equipment:

Shop Equipment, SC 4910-95-CL-A74
Tool Kit, SC 5180-90-CL-N26

Materials/Parts:

Packing (AR)

Caps and Plugs Appendix C, item 7

Rags Appendix C, item 32

Equipment Condition:

Reference	Condition Description
Page 2-22	Backhoe in Three-Point Stance
Page 2-23	Hydraulic Pressure Relieved

General Safety Instructions:

WARNING

- High pressure hydraulics [oil under 2450 psi (16,893 kPa)] operate this equipment. Never disconnect any hydraulic line or fitting without first dropping pressure to zero. A high pressure oil stream can pierce body and cause severe injury to personnel.
- Fuel and oil are slippery and can cause falls. To avoid injury, wipe up spilled fuel or oil with rags.

REMOVAL

CAUTION

Cap or plug all ports and ends of hoses and tubes to prevent contamination of hydraulic oil. Failure to do so may result in damage to equipment.

NOTE

- Tag lines prior to removal to aid in installation.
- Discard packing(s).

REMOVE backhoe control valve, boom section hydraulic LINES and FITTINGS using illustration and legend as a guide.

INSTALLATION

NOTE

Install new packing(s).

INSTALL backhoe control valve, boom section hydraulic LINES and FITTINGS using illustration and legend as a guide.

BACKHOE CONTROL VALVE, BOOM SECTION HYDRAULIC LINES AND FITTINGS REPLACEMENT (CONT)

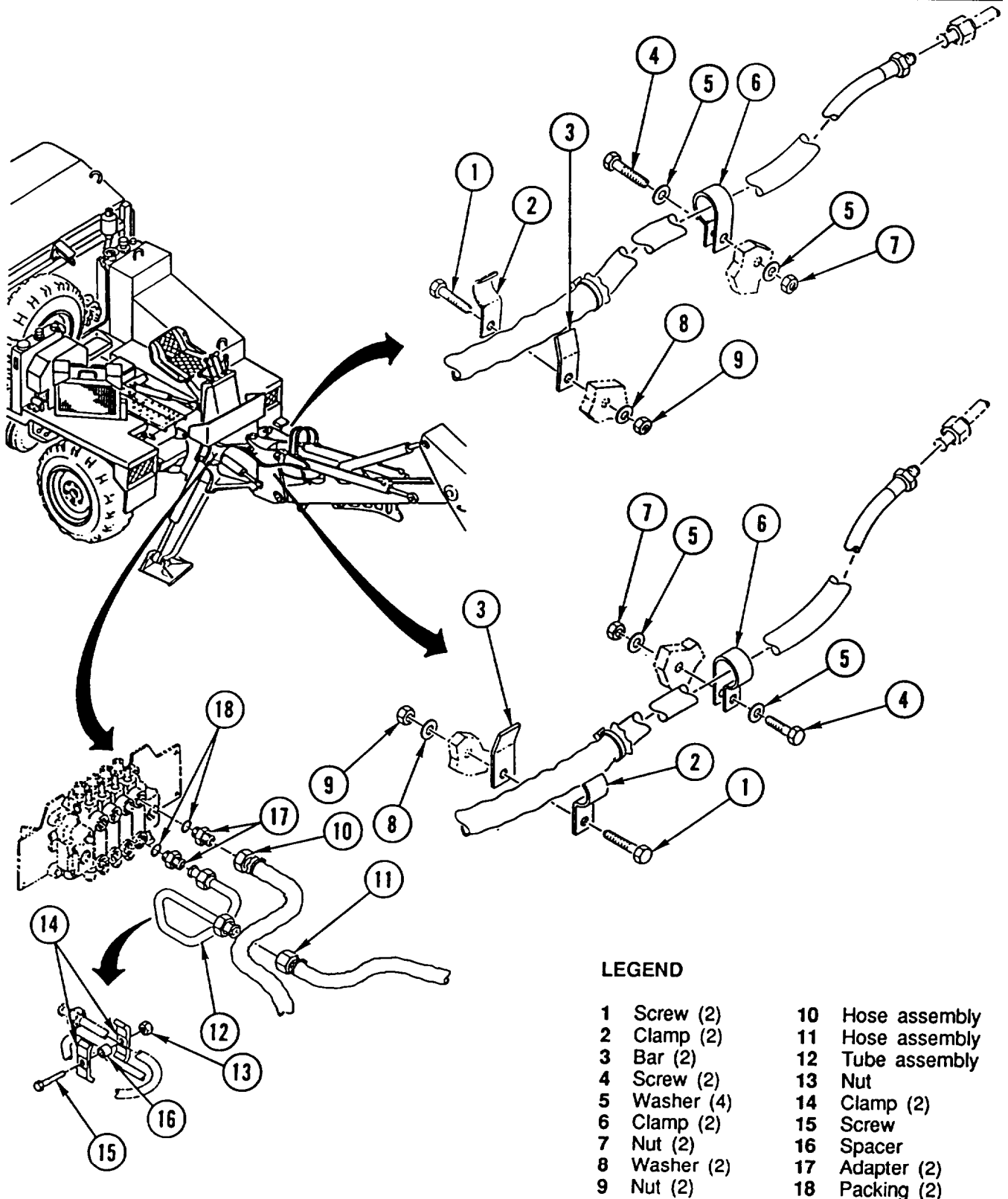

BACKHOE DIPPER CYLINDER HYDRAULIC LINES AND FITTINGS REPLACEMENT

This task covers: a. Removal b. Installation

INITIAL SETUP

Applicable Configuration:

SEE

Tools and Special Equipment:

Shop Equipment, SC 4910-95-CL-A74
Tool Kit, SC 5180-90-CL-N26

Materials/Parts:

Packing (AR)

Washer, Lock

Caps and Plugs Appendix C, Item 7

Rags Appendix C, Item 32

Equipment Condition:

Reference

Condition Description

Page 2-22 Backhoe in Three-Point Stance

Page 2-23 Hydraulic Pressure Relieved

General Safety Instructions:

WARNING

- High pressure hydraulics [oil under 2450 psi (16,893 kPa)] operate this equipment. Never disconnect any hydraulic line or fitting without first dropping pressure to zero. A high pressure oil stream can pierce body and cause severe injury to personnel.
- Fuel and oil are slippery and can cause falls. To avoid injury, wipe up spilled fuel or oil with rags.

REMOVAL

CAUTION

Cap or plug all ports and ends of hoses and tubes to prevent contamination of hydraulic oil. Failure to do so may result in damage to equipment.

NOTE

- Tag lines prior to removal to aid in installation.
- Discard packing(s) and lock washer(s).

REMOVE backhoe dipper cylinder hydraulic LINES and FITTINGS using illustration and legend as a guide.

INSTALLATION

NOTE

Install new packing(s) and new lock washer(s).

INSTALL backhoe dipper cylinder hydraulic LINES and FITTINGS using illustration and legend as a guide.

**BACKHOE DIPPER CYLINDER HYDRAULIC LINES AND FITTINGS
REPLACEMENT (CONT)**

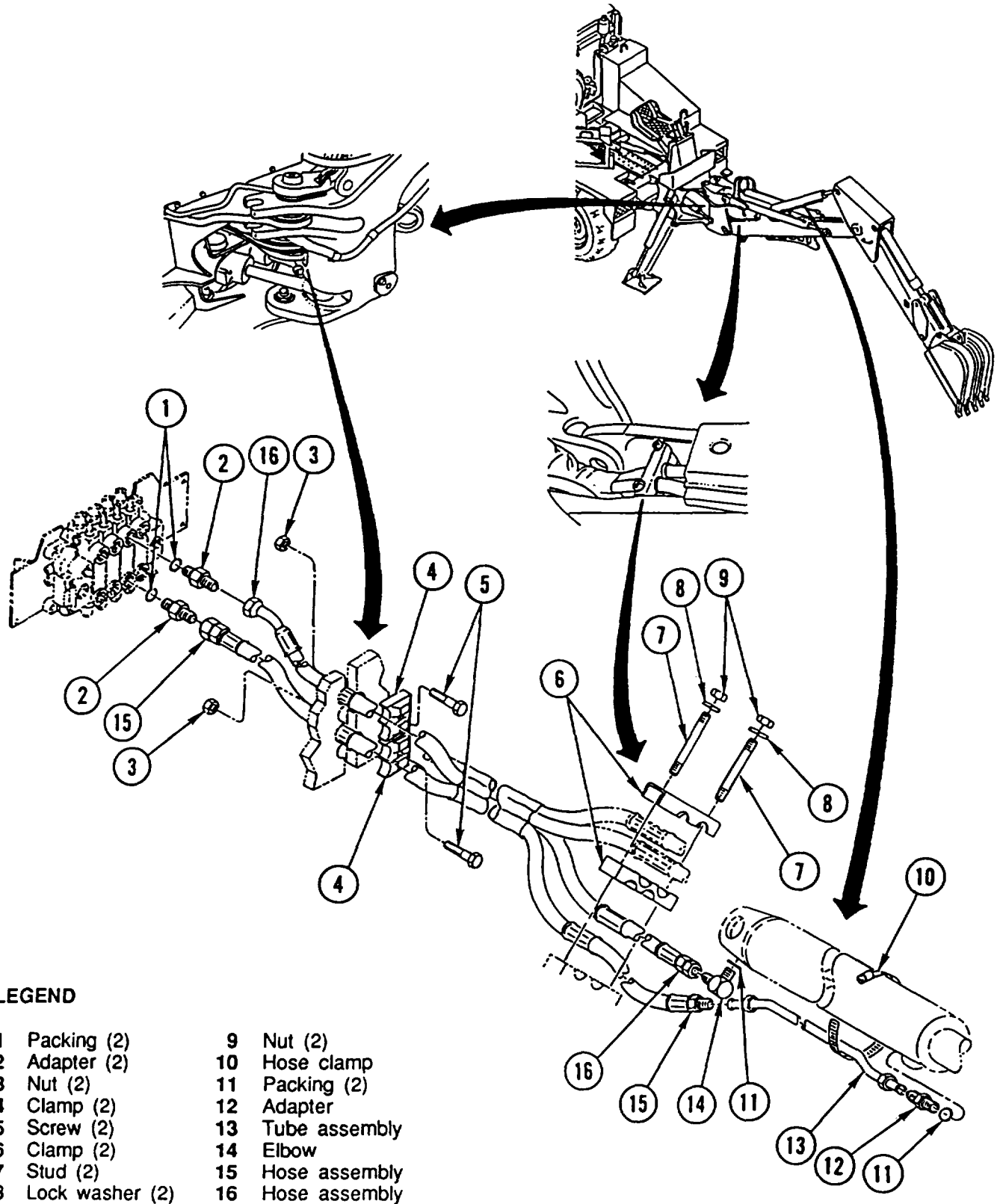

LEGEND

- | | |
|-------------------|------------------|
| 1 Packing (2) | 9 Nut (2) |
| 2 Adapter (2) | 10 Hose clamp |
| 3 Nut (2) | 11 Packing (2) |
| 4 Clamp (2) | 12 Adapter |
| 5 Screw (2) | 13 Tube assembly |
| 6 Clamp (2) | 14 Elbow |
| 7 Stud (2) | 15 Hose assembly |
| 8 Lock washer (2) | 16 Hose assembly |

BACKHOE BUCKET CYLINDER HYDRAULIC LINES AND FITTINGS REPLACEMENT

This task covers: a. Removal b. Installation

INITIAL SETUP

Applicable Configuration:

SEE

Tools and Special Equipment:

Shop Equipment, SC 4910-95-CL-A74
Tool Kit, SC 5180-90-CL-N26

Materials/Parts:

Washer, Lock (AR)

Packing (AR)

Caps and Plugs Appendix C, Item 7

Rags Appendix C, Item 32

Equipment Condition:

Reference	Condition Description
Page 2-22	Backhoe in Three-Point Stance
Page 2-23	Hydraulic Pressure Relieved

General Safety Instructions:

WARNING

- High pressure hydraulics [oil under 2450 psi (16,893 kPa)] operate this equipment. Never disconnect any hydraulic line or fitting without first dropping pressure to zero. A high pressure oil stream can pierce body and cause severe injury to personnel.
- Fuel and oil are slippery and can cause falls. To avoid injury, wipe up spilled fuel or oil with rags.

REMOVAL

CAUTION

Cap or plug all ports and ends of hoses and tubes to prevent contamination of hydraulic oil. Failure to do so may result in damage to equipment.

NOTE

- Tag lines prior to removal to aid in installation.
- Discard lock washer(s) and packing.

REMOVE backhoe bucket cylinder hydraulic LINES and FITTINGS using illustration and legend as a guide.

INSTALLATION

NOTE

Install new lock washer(s) and new packing.

INSTALL backhoe bucket cylinder hydraulic LINES and FITTINGS using illustration and legend as a guide.

**BACKHOE BUCKET CYLINDER HYDRAULIC LINES AND FITTINGS
REPLACEMENT (CONT)**

LEGEND

- 1 Screw (2)
- 2 Lock washer (2)
- 3 Retaining strap (2)
- 4 Spacer (2)
- 5 Tube assembly
- 6 Tube assembly
- 7 Hose assembly (2)
- 8 Tube assembly
- 9 Adapter
- 10 Hose clamp
- 11 Adapter
- 12 Packing

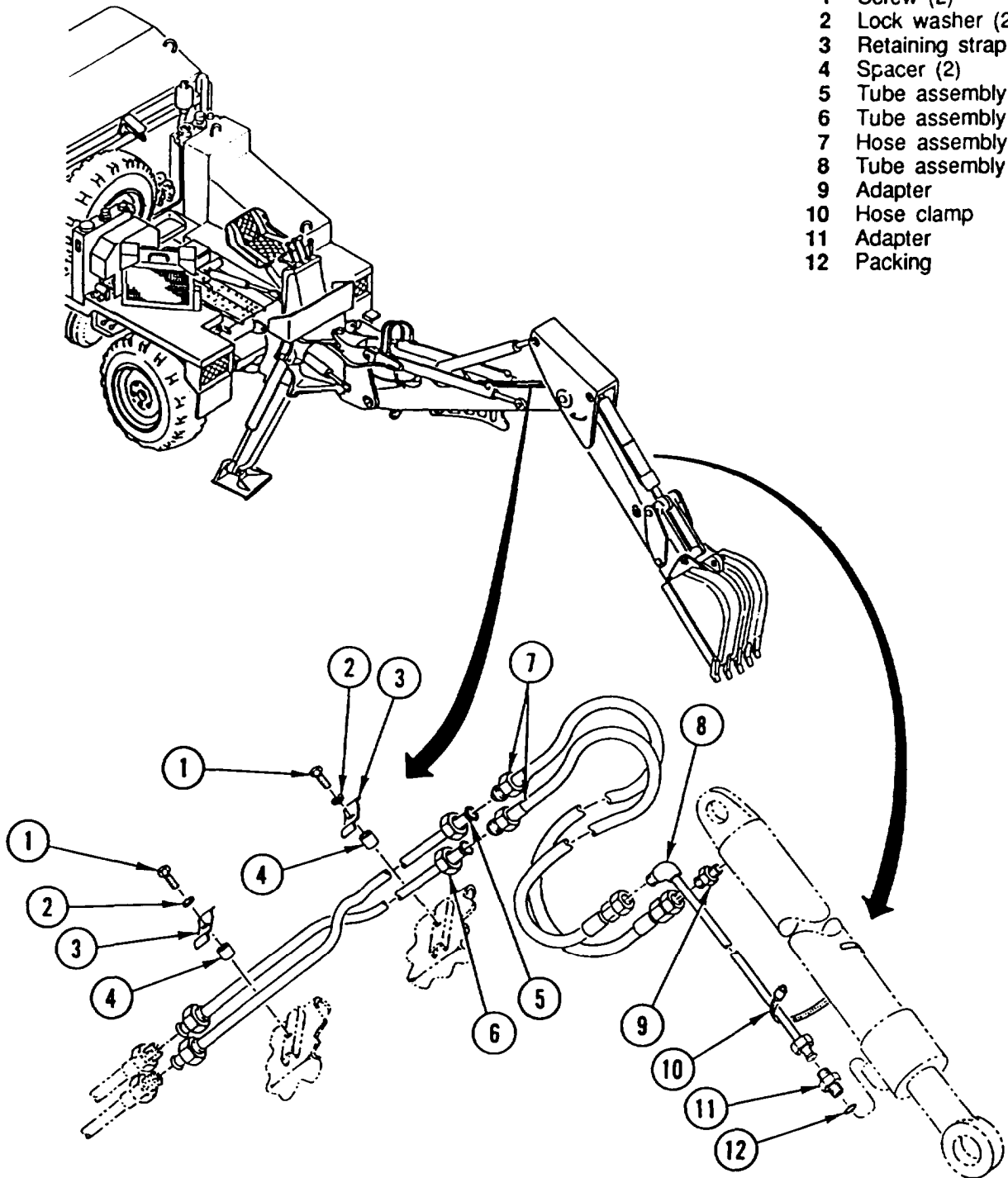

BACKHOE CONTROL VALVE, BUCKET SECTION HYDRAULIC LINES AND FITTINGS REPLACEMENT

This task covers: a. Removal b. Installation

INITIAL SETUP

Applicable Configuration:

SEE

Tools and Special Equipment:

Shop Equipment, SC 4910-95-CL-A74
Tool Kit, SC 5180-90-CL-N26

Materials/Parts:

Washer, Lock (AR)

Packing (AR)

Caps and Plugs Appendix C, Item 7

Rags Appendix C, Item 32

Equipment Condition:

Reference	Condition Description
Page 2-22	Backhoe in Three-Point Stance
Page 2-23	Hydraulic Pressure Relieved

General Safety Instructions:

WARNING

- High pressure hydraulics [oil under 2450 psi (16,893 kPa)] operate this equipment. Never disconnect any hydraulic line or fitting without first dropping pressure to zero. A high pressure oil stream can pierce body and cause severe injury to personnel.
- Fuel and oil are slippery and can cause falls. To avoid injury, wipe up spilled fuel or oil with rags.

REMOVAL

CAUTION

Cap or plug all ports and ends of hoses and tubes to prevent contamination of hydraulic oil. Failure to do so may result in damage to equipment.

NOTE

- Tag lines prior to removal to aid in installation.
- Discard lock washer(s) and packing(s).

REMOVE backhoe control valve, bucket section hydraulic LINES and FITTINGS using illustration and legend as a guide.

INSTALLATION

NOTE

Install new lock washer(s) and new packing(s).

INSTALL backhoe control valve, bucket section hydraulic LINES and FITTINGS using illustration and legend as a guide.

BACKHOE CONTROL VALVE, BUCKET SECTION HYDRAULIC LINES AND FITTINGS REPLACEMENT (CONT)

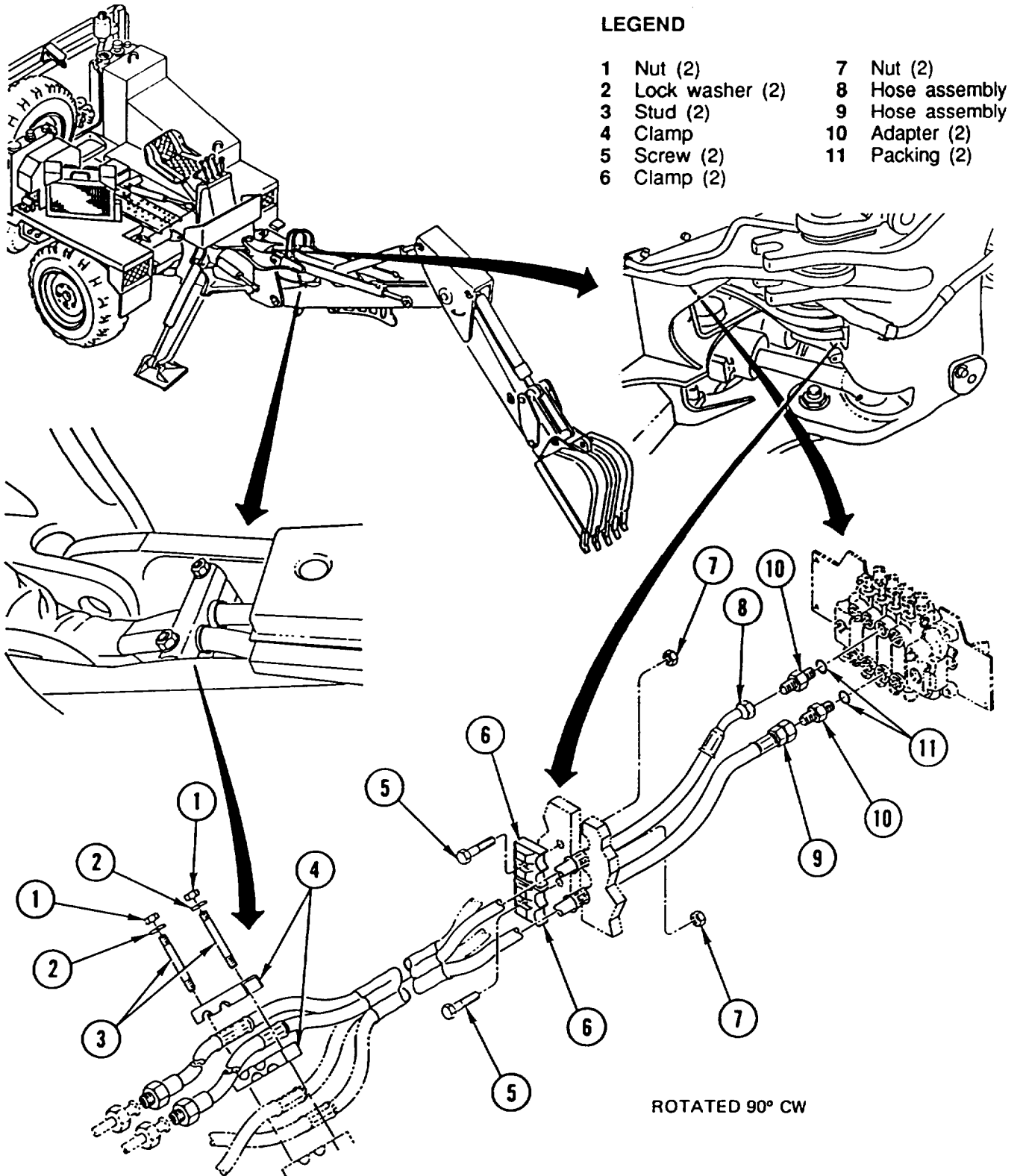

FORKLIFT TILT CYLINDER HYDRAULIC LINES AND FITTINGS REPLACEMENT

This task covers: a. Removal b. Installation

INITIAL SETUP

Applicable Configuration:

HMMH

Tools and Special Equipment:

Shop Equipment, SC 4910-95-CL-A74
Tool Kit, SC 5180-90-CL-N26

Materials/Parts:

Packing (AR)

Caps and Plugs Appendix C, Item 7

Rags Appendix C, Item 32

References:

TM 5-2420-224-10

Equipment Condition:

Reference	Condition Description
TM 5-2420-224-10	Forklift Lowered to Ground
Page 2-23	Hydraulic Pressure Relieved

General Safety Instructions:

WARNING

- High pressure hydraulics [oil under 2450 psi (16,893 kPa)] operate this equipment. Never disconnect any hydraulic line or fitting without first dropping pressure to zero. A high pressure oil stream can pierce body and cause severe injury to personnel.
- Fuel and oil are slippery and can cause falls. To avoid injury, wipe up spilled fuel or oil with rags.

REMOVAL

CAUTION

Cap or plug all ports and ends of hoses and tubes to prevent contamination of hydraulic oil. Failure to do so may result in damage to equipment.

NOTE

- Tag lines prior to removal to aid in installation.
- Discard packing(s).

REMOVE forklift tilt cylinder hydraulic LINES and FITTINGS using illustration and legend as a guide.

INSTALLATION

NOTE

Install new packing(s).

INSTALL forklift tilt cylinder hydraulic LINES and FITTINGS using illustration and legend as a guide.

**FORKLIFT TILT CYLINDER HYDRAULIC LINES AND FITTINGS
REPLACEMENT (CONT)**

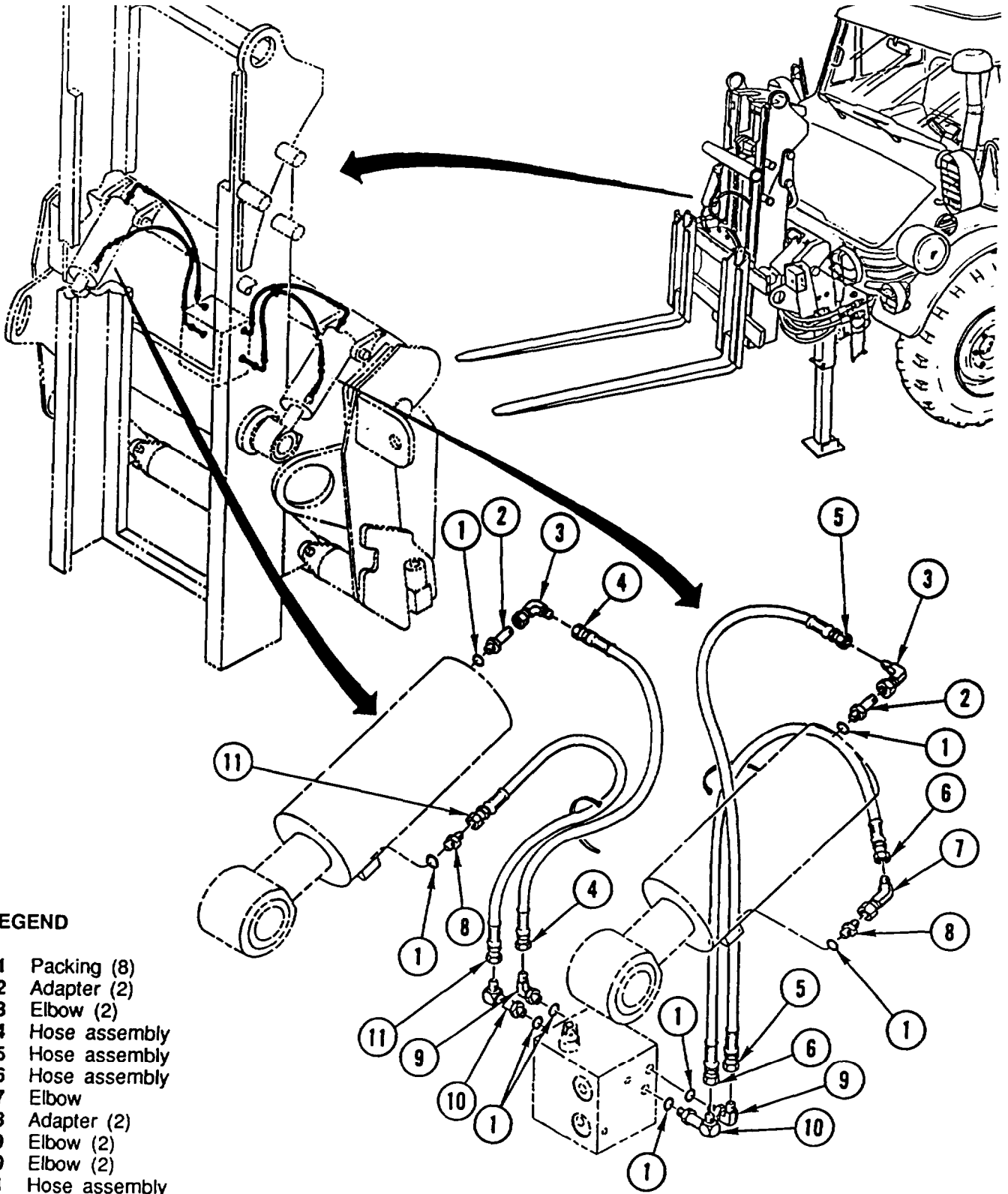

LEGEND

- 1 Packing (8)
- 2 Adapter (2)
- 3 Elbow (2)
- 4 Hose assembly
- 5 Hose assembly
- 6 Hose assembly
- 7 Elbow
- 8 Adapter (2)
- 9 Elbow (2)
- 10 Elbow (2)
- 11 Hose assembly

FORKLIFT HYDRAULIC LINES AND FITTINGS REPLACEMENT

This task covers: a. Removal b. Installation

INITIAL SETUP

Applicable Configuration:

HMMH

Tools and Special Equipment:

Shop Equipment, SC 4910-95-CL-A74
Tool Kit, SC 5180-90-CL-N26

Materials/Parts:

Packing (AR)

Washer, Lock (AR)

Caps and Plugs Appendix C, Item 7

Rags Appendix C, Item 32

References:

TM 5-2420-224-10

Equipment Condition:

Reference	Condition Description
TM 5-2420-224-10	Forklift Lowered to Ground
Page 2-23	Hydraulic Pressure Relieved

General Safety Instructions:

WARNING

- High pressure hydraulics [oil under 2450 psi (16,893 kPa)] operate this equipment. Never disconnect any hydraulic line or fitting without first dropping pressure to zero. A high pressure oil stream can pierce body and cause severe injury to personnel.
- Fuel and oil are slippery and can cause falls. To avoid injury, wipe up spilled fuel or oil with rags.

REMOVAL

CAUTION

Cap or plug all ports and ends of hoses and tubes to prevent contamination of hydraulic oil. Failure to do so may result in damage to equipment.

NOTE

- Tag lines prior to removal to aid in installation.
- Discard packing(s) and lock washer(s).

REMOVE forklift hydraulic LINES and FITTINGS using illustration and legend as a guide.

INSTALLATION

NOTE

Install new packing(s) and new lock washer(s).

INSTALL forklift hydraulic LINES and FITTINGS using illustration and legend as a guide.

FORKLIFT HYDRAULIC LINES AND FITTINGS REPLACEMENT (CONT)

LEGEND

- | | | | |
|---------------------|---------------------------|--------------------|-------------------|
| 1 Screw (2) | 7 Adapter | 13 Adapter | 19 Elbow |
| 2 Nut (2) | 8 Shutoff valve (2) | 14 Reducer | 20 Junction block |
| 3 Check valve (2) | 9 Female quick disconnect | 15 Swivel elbow | 21 Nipple |
| 4 Tee (2) | 10 Male quick disconnect | 16 Hose assembly | 22 Adapter |
| 5 Packing (2) | 11 Male quick disconnect | 17 Screw (2) | 23 Tube assembly |
| 6 Hose assembly (2) | 12 Packing (3) | 18 Lock washer (2) | 24 Elbow |

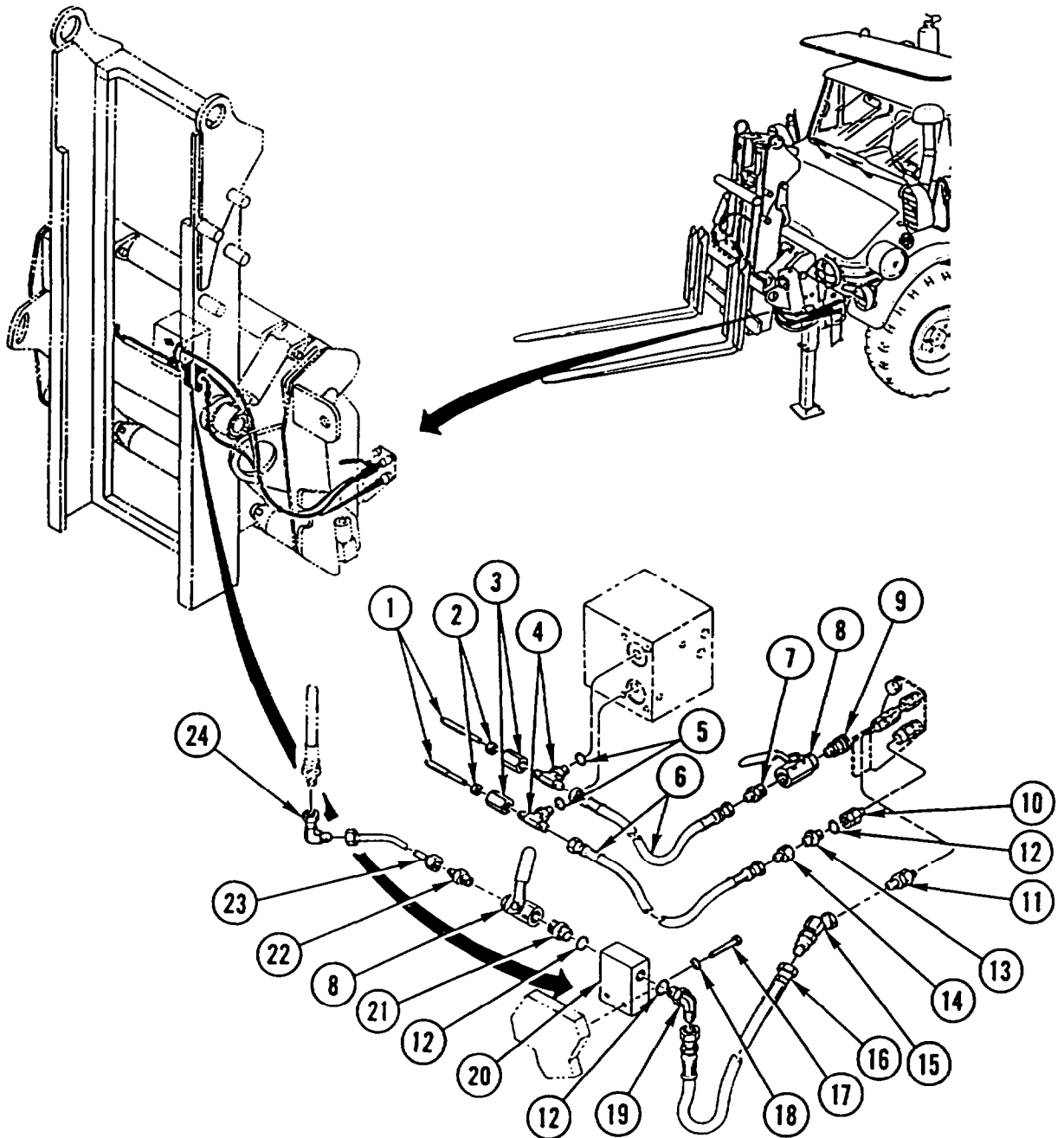

FORKLIFT ROTATOR CYLINDER HYDRAULIC LINES AND FITTINGS REPLACEMENT

This task covers: a. Removal b. Installation

INITIAL SETUP

Applicable Configuration:

HMMH

Tools and Special Equipment:

Shop Equipment, SC 4910-95-CL-A74
Tool Kit, SC 5180-90-CL-N26

Materials/Parts:

Packing (AR)

Caps and Plugs Appendix C, Item 7

Rags Appendix C, Item 32

References:

TM 5-2420-224-10

Equipment Condition:

Reference	Condition Description
TM 5-2420-224-10	Forklift Lowered to Ground
Page 2-23	Hydraulic Pressure Relieved

General Safety instructions:

WARNING

- High pressure hydraulics [oil under 2450 psi (16,893 kPa)] operate this equipment. Never disconnect any hydraulic line or fitting without first dropping pressure to zero. A high pressure oil stream can pierce body and cause severe injury to personnel.
- Fuel and oil are slippery and can cause falls. To avoid injury, wipe up spilled fuel or oil with rags.

REMOVAL

CAUTION

Cap or plug all ports and ends of hoses and tubes to prevent contamination of hydraulic oil. Failure to do so may result in damage to equipment.

NOTE

- Tag lines prior to removal to aid in installation.
- Discard packing(s).

REMOVE forklift rotator cylinder hydraulic LINES and FITTINGS using illustration and legend as a guide.

INSTALLATION

NOTE

Install new packing(s).

INSTALL forklift rotator cylinder hydraulic LINES and FITTINGS using illustration and legend as a guide.

FORKLIFT ROTATOR CYLINDER HYDRAULIC LINES AND FITTINGS REPLACEMENT (CONT)

LEGEND

- 1 Packing (2)
- 2 Elbow (2)
- 3 Hose assembly
- 4 Hose assembly

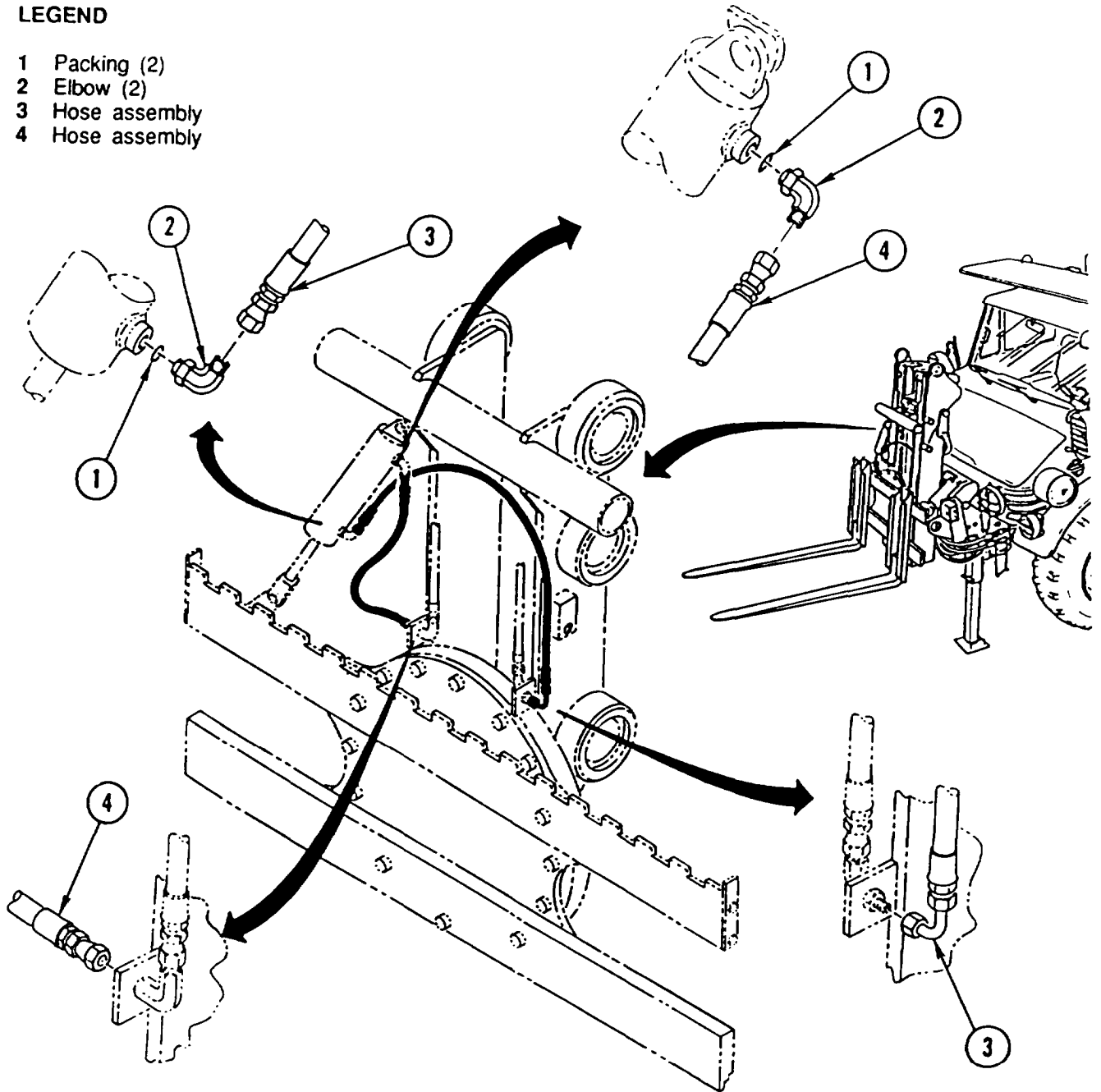

FORKLIFT PULLEY HYDRAULIC LINES AND FITTINGS REPLACEMENT

This task covers: a. Removal b. Installation

INITIAL SETUP

Applicable Configuration:

HMMH

Tools and Special Equipment:

Shop Equipment, SC 4910-95-CL-A74
Tool Kit, SC 5180-90-CL-N26

Materials/Parts:

Washer, Lock (AR)

Caps and Plugs Appendix C, Item 7

Rags Appendix C, Item 32

References:

TM 5-2420-224-10

Equipment Condition:

Reference	Condition Description
TM 5-2420-224-10	Forklift Lowered to Ground
Page 2-23	Hydraulic Pressure Relieved

General Safety Instructions:

WARNING

- High pressure hydraulics [oil under 2450 psi (16,893 kPa)] operate this equipment. Never disconnect any hydraulic line or fitting without first dropping pressure to zero. A high pressure oil stream can pierce body and cause severe injury to personnel.
- Fuel and oil are slippery and can cause falls. To avoid injury, wipe up spilled fuel or oil with rags.

REMOVAL

CAUTION

Cap or plug all ports and ends of hoses and tubes to prevent contamination of hydraulic oil. Failure to do so may result in damage to equipment.

NOTE

- Tag lines prior to removal to aid in installation.
- Discard lock washer(s).

REMOVE forklift pulley hydraulic LINES and FITTINGS using illustration and legend as a guide.

INSTALLATION

NOTE

Install new lock washer(s).

INSTALL forklift pulley hydraulic LINES and FITTINGS using illustration and legend as a guide.

FORKLIFT PULLEY HYDRAULIC LINES AND FITTINGS REPLACEMENT (CONT)

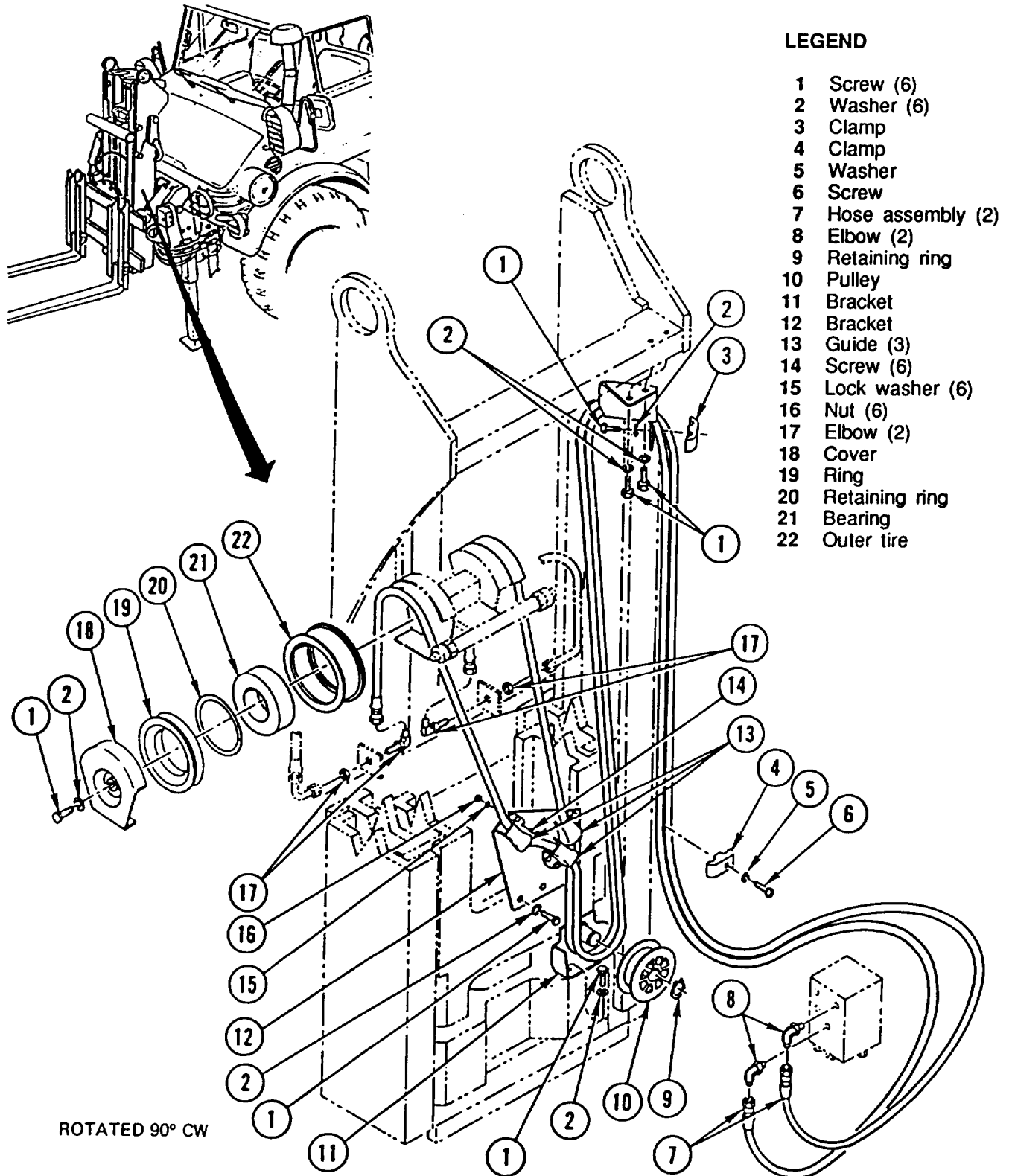

FORKLIFT LIFT CYLINDER HYDRAULIC LINES AND FITTINGS REPLACEMENT

This task covers: a. Removal b. Installation

INITIAL SETUP

Applicable Configuration:

HMMH

Tools and Special Equipment:

Shop Equipment, SC 4910-95-CL-A74
Tool Kit, SC 5180-90 -CL-N26

Materials/Parts:

Packing (AR)

Washer, Lock (AR)

Caps and Plugs Appendix C, Item 7

Rags Appendix C, Item 32

References:

TM 5-2420-224-10

Equipment Condition:

Reference

Condition Description

TM 5-2420-224-10 Forklift Lowered to Ground

Page 2-23 Hydraulic Pressure Relieved

General Safety Instructions:

WARNING

- High pressure hydraulics [oil under 2450 psi (16,893 kPa)] operate this equipment. Never disconnect any hydraulic line or fitting without first dropping pressure to zero. A high pressure oil stream can pierce body and cause severe injury to personnel.
- Fuel and oil are slippery and can cause falls. To avoid injury, wipe up spilled fuel or oil with rags.

REMOVAL

CAUTION

Cap or plug all ports and ends of hoses and tubes to prevent contamination of hydraulic oil. Failure to do so may result in damage to equipment.

NOTE

Discard lock washer(s) and packing.

REMOVE forklift lift cylinder hydraulic LINES and FITTINGS using illustration and legend as a guide.

FORKLIFT LIFT CYLINDER HYDRAULIC LINES AND FITTINGS REPLACEMENT (CONT)

INSTALLATION

NOTE

Install new lock washer(s) and new packing.

INSTALL forklift lift cylinder hydraulic LINES and FITTINGS using illustration and legend as a guide.

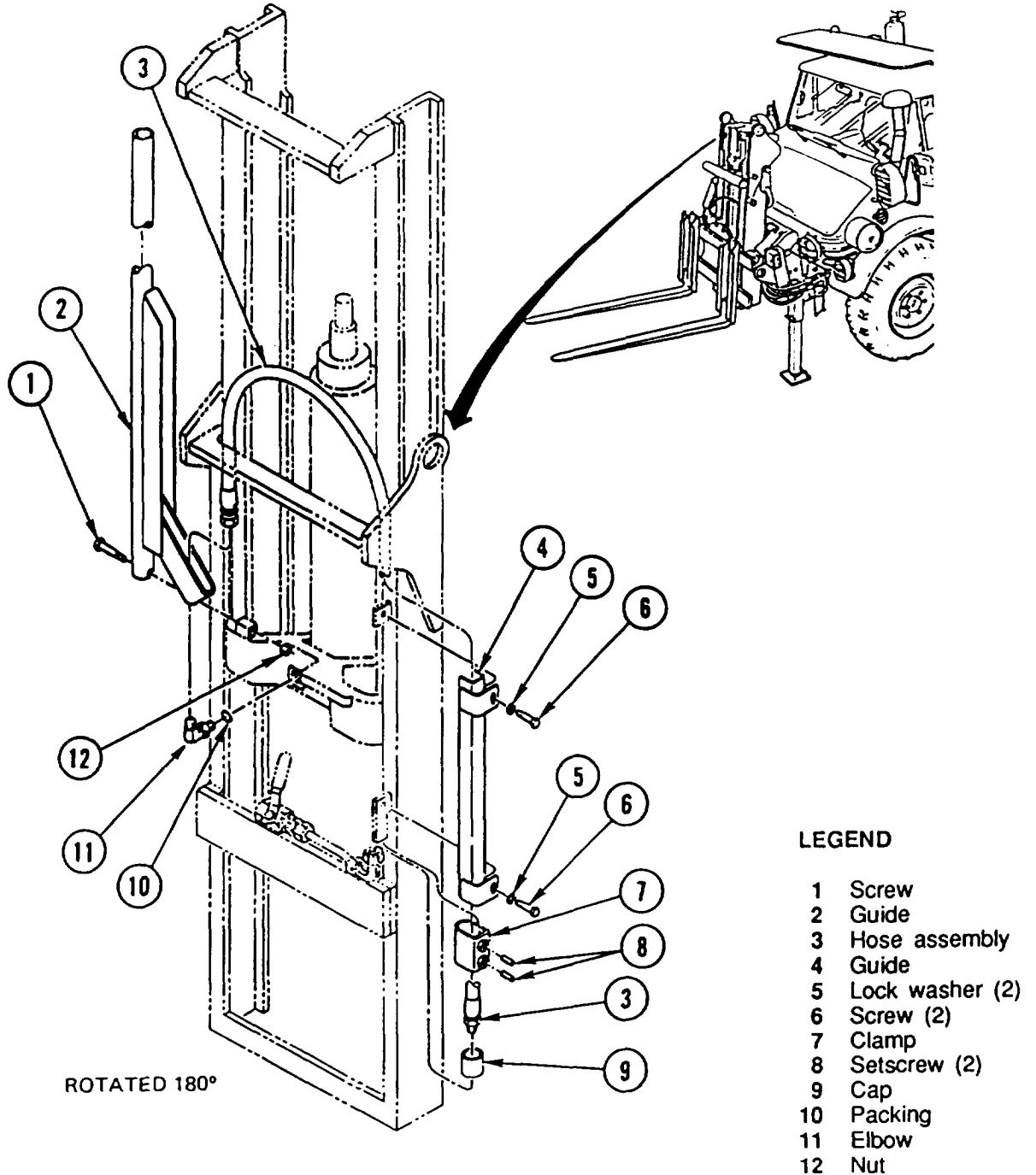

FORKLIFT LIFT CYLINDER BLEEDING

This task covers: Bleeding

INITIAL SETUP

Applicable Configuration:

HMMH

Tools and Special Equipment:

Shop Equipment, SC 4910-95-CL-A74

Tool Kit, SC 5180-90-CL-N26

Hex Tube Wrench, P/N 661507

Tubing, P/N 661922

Materials/Parts:

Rags Appendix C, Item 32

References:

TM 5-2420-224-10

General Safety Instructions:

WARNING

- Do not work on forklift lift cylinder with load on forks or while anyone is near forklift controls. To do so could result in injury to personnel.
- Fuel and oil are slippery and can cause falls. To avoid injury, wipe up spilled fuel or oil with rags.

Equipment Condition:

Reference	Condition Description
TM 5-2420-224-10	Forklift Lowered to Ground

BLEEDING

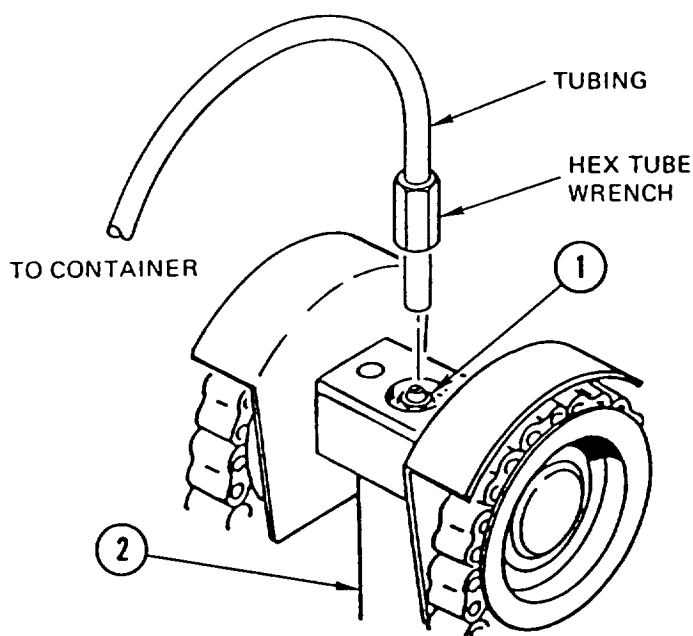

FORKLIFT LIFT CYLINDER BLEEDING (CONT)

1. With no load on forks, extend and retract mast through one complete cycle.
2. With mast fully lowered, check front hydraulic tank and top off as necessary (TM 5-2420-224-10).
3. Raise and retract mast completely at least four more times. This will force air in system to lift cylinder center cavity under bleeder valve (1).
4. Raise carriage assembly approximately 10 in. (25.4 cm) off ground.
5. Slide tubing through hex tube wrench and onto bleeder valve (1) located on top of lift cylinder crosshead (2). Place other end of tubing in suitable container to catch oil.
6. Open bleeder valve (1) no more than 1/4-turn with hex tube wrench. Weight of carriage assembly will force air and hydraulic oil out of lift cylinder through bleeder valve (1).
7. If carriage assembly reaches bottom of its travel before all air is bled, close bleeder valve (1) and repeat steps 4 thru 6.
8. When oil stream no longer contains air bubbles, close bleeder valve (1) and tighten to 25-27 lb-ft (44.9-46.6 N.m).
9. Fill front hydraulic tank (TM 5-2420-224-10).

CRANE EXTERNAL END EXTENSION CYLINDER HYDRAULIC LINES AND FITTINGS REPLACEMENT

This task covers: a. Removal b. Installation

INITIAL SETUP

Applicable Configuration:

HMMH

Tools and Special Equipment:

Shop Equipment, SC 4910-95-CL-A74
Tool Kit, SC 5180-90-CL-N26

Materials/Parts:

Packing (AR)

Washer, Lock (AR)

Nut, Lock (AR)

Caps and Plugs Appendix C, Item 7

Rags Appendix C, Item 32

Equipment Condition:

Reference	Condition Description
Page 2-23	Crane in Three-Point Stance
Page 2-23	Hydraulic Pressure Relieved

General Safety Instructions:

WARNING

- High pressure hydraulics [oil under 2450 psi (16,893 kPa)] operate this equipment: Never disconnect any hydraulic line or fitting without first dropping pressure to zero. A high pressure oil stream can pierce body and cause severe injury to personnel.
- Fuel and oil are slippery and can cause falls. To avoid injury, wipe up spilled fuel or oil with rags.

REMOVAL

CAUTION

Cap or plug all ports and ends of hoses and tubes to prevent contamination of hydraulic oil. Failure to do so may result in damage to equipment.

NOTE

- Tag lines prior to removal to aid in installation.
- Discard packing(s), lock washer(s), and lock nut(s).

REMOVE crane external end extension cylinder hydraulic LINES and FITTINGS using illustration and legend as a guide.

INSTALLATION

NOTE

Install new packing(s), new lock washer(s), and new lock nut(s).

INSTALL crane external end extension cylinder hydraulic LINES and FITTINGS using illustration and legend as a guide.

CRANE EXTERNAL END EXTENSION CYLINDER HYDRAULIC LINES AND FITTINGS REPLACEMENT (CONT)

LEGEND

- | | | |
|-----------------------|--------------------|-----------------|
| 1 Elbow (2) | 7 Lock washer | 13 Lock nut (2) |
| 2 Packing (2) | 8 Screw | 14 Elbow |
| 3 Hose assembly (2) | 9 Washer (6) | 15 Elbow |
| 4 Retaining strap (7) | 10 Lock washer (6) | 16 Packing (2) |
| 5 Screw | 11 Screw (6) | 17 Fitting (2) |
| 6 Nut | 12 Clamp (3) | 18 Packing (2) |

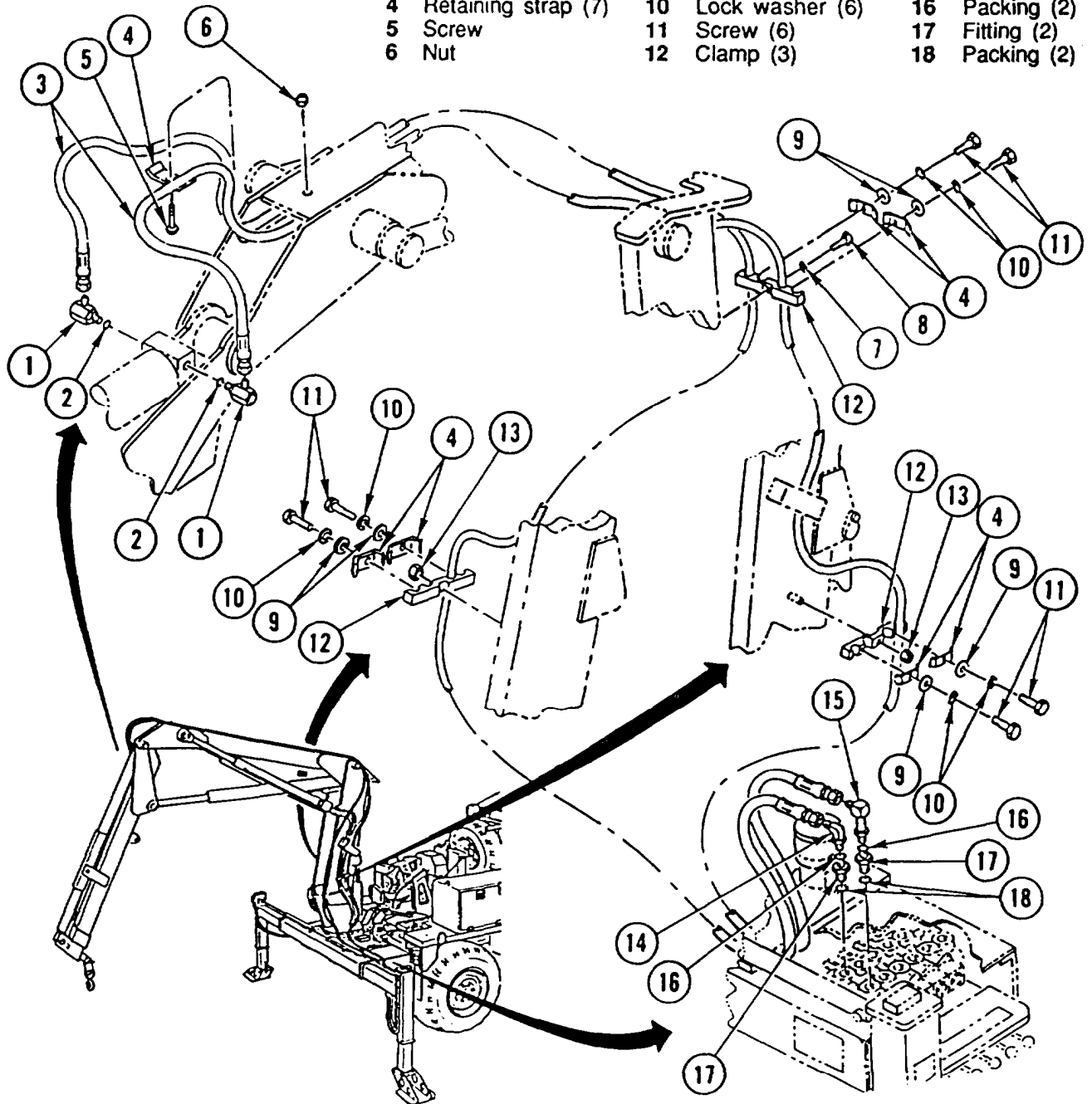

CRANE TURNTABLE MOTOR HYDRAULIC LINES AND FITTINGS REPLACEMENT

This task covers: a. Removal b. Installation

INITIAL SETUP

Applicable Configuration:

HMMH

Tools and Special Equipment:

Shop Equipment, SC 4910-95-CL-A74

Tool Kit, SC 5180-90-CL-N26

Materials/Parts:

Packing (AR)

Caps and Plugs Appendix C, Item 7

Rags Appendix C, Item 32

Equipment Condition:

Reference	Condition Description
-----------	-----------------------

Page 2-23	Crane in Three-Point Stance
-----------	-----------------------------

Page 2-23	Hydraulic Pressure Relieved
-----------	-----------------------------

General Safety Instructions:

WARNING

High pressure hydraulics [oil under 2450 psi (16,893 kPa)] operate this equipment. Never disconnect any hydraulic line or fitting without first dropping pressure to zero. A high pressure oil stream can pierce body and cause severe injury to personnel.

Fuel and oil are slippery and can cause falls. To avoid injury, wipe up spilled fuel or oil with rags.

REMOVAL

CAUTION

Cap or plug all ports and ends of hoses and tubes to prevent contamination of hydraulic oil. Failure to do so may result in damage to equipment.

NOTE

- Tag lines prior to removal to aid in installation.
- Discard packing(s).

REMOVE crane turntable motor hydraulic LINES and FITTINGS using illustration and legend as a guide.

INSTALLATION

NOTE

Install new packing(s).

INSTALL crane turntable motor hydraulic LINES and FITTINGS using illustration and legend as a guide.

CRANE TURNTABLE MOTOR HYDRAULIC LINES AND FITTINGS REPLACEMENT (CONT)

LEGEND

- 1 Packing (2)
- 2 Adapter (2)
- 3 Elbow (2)
- 4 Hose assembly (2)
- 5 Elbow
- 6 Packing (2)
- 7 Fitting (2)
- 8 Packing (2)
- 9 Elbow
- 10 Reducer (2)

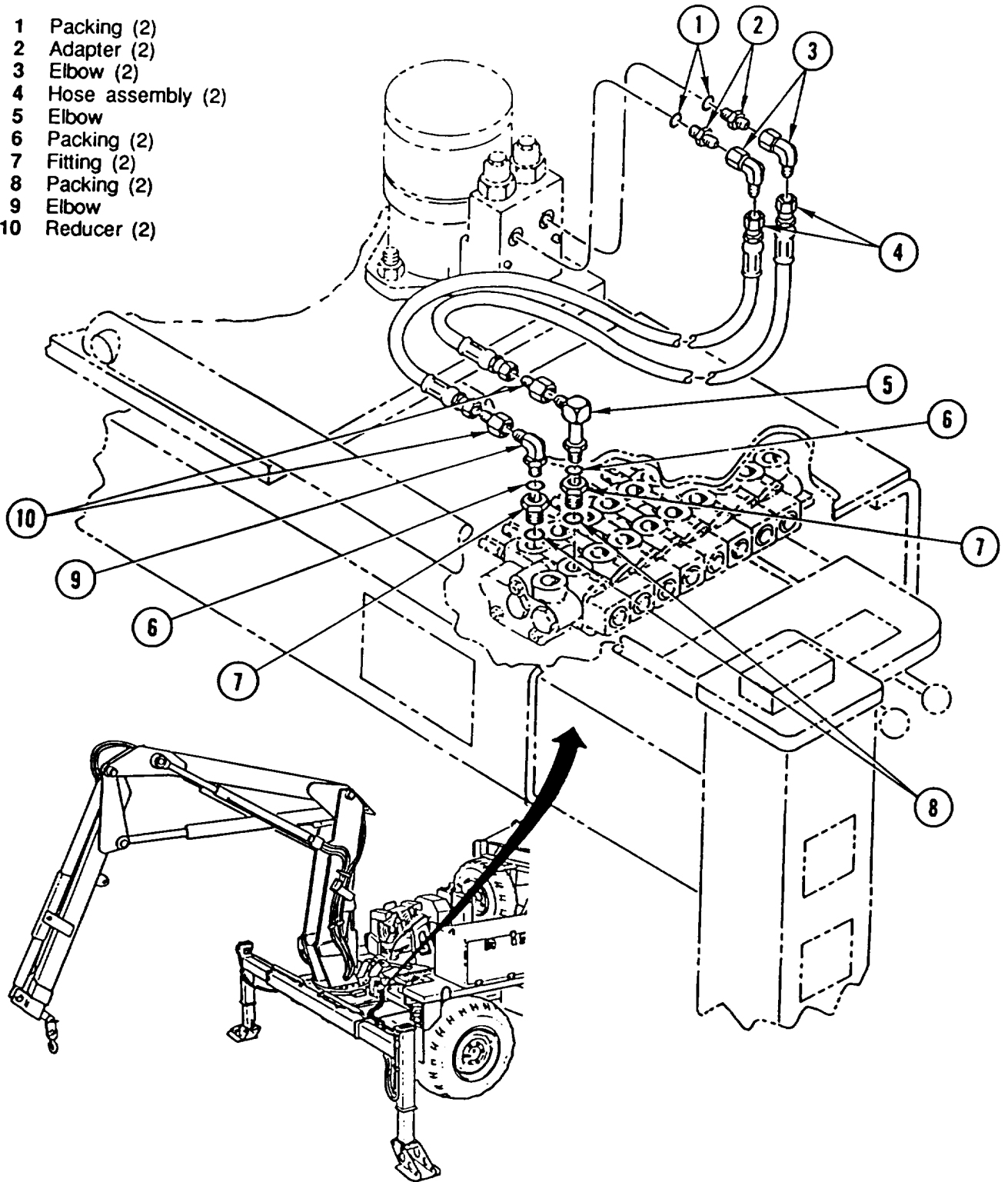

CRANE INNER BOOM LIFT CYLINDER HYDRAULIC LINES AND FITTINGS REPLACEMENT

This task covers: a. Removal b Installation

Applicable Configuration:

HMMH

Tools and Special Equipment:

Shop Equipment, SC 4910-95-CL-A74
Tool Kit, SC 5180-90-CL-N26

Materials/Parts:

Packing (AR)

Washer, Lock (AR)

Caps and Plugs Appendix C, Item 7

Rags Appendix C, Item 32

Equipment Condition:

Reference

Page 2-23

Condition Description

Crane in Three-Point
Stance

Page 2-23

Hydraulic Pressure
Relieved

General Safety Instructions:

WARNING

- High pressure hydraulics [oil under 2450 psi (16,893 kPa)] operate this equipment. Never disconnect any hydraulic line or fitting without first dropping pressure to zero. A high pressure oil stream can pierce body and cause severe injury to personnel.
- Fuel and oil are slippery and can cause falls. To avoid injury, wipe up spilled fuel or oil with rags.

CAUTION

Cap or plug all ports and ends of hoses and tubes to prevent contamination of hydraulic oil. Failure to do so may result in damage to equipment.

NOTE

- Tag lines prior to removal to aid in installation.
- Discard packing(s) and lock washer(s).

REMOVE crane inner boom lift cylinder hydraulic LINES and FITTINGS using illustration and legend as a guide.

INSTALLATION

NOTE

Install new packing(s) and new lock washer(s).

INSTALL crane inner boom lift cylinder hydraulic LINES and FITTINGS using illustration and legend as a guide.

CRANE INNER BOOM LIFT CYLINDER HYDRAULIC LINES AND FITTINGS REPLACEMENT (CONT)

LEGEND

- 1 Packing (4)
- 2 Adapter (4)
- 3 Hose assembly (4)
- 4 Retaining strap (4)
- 5 Washer (4)
- 6 Lock washer (4)
- 7 Nut (2)
- 8 Screw (2)
- 9 Swivel joint (4)
- 10 Elbow (2)
- 11 Tee (2)
- 12 Hose assembly (2)
- 13 Elbow
- 14 Packing (2)
- 15 Fitting (2)
- 16 Packing (2)
- 17 Elbow

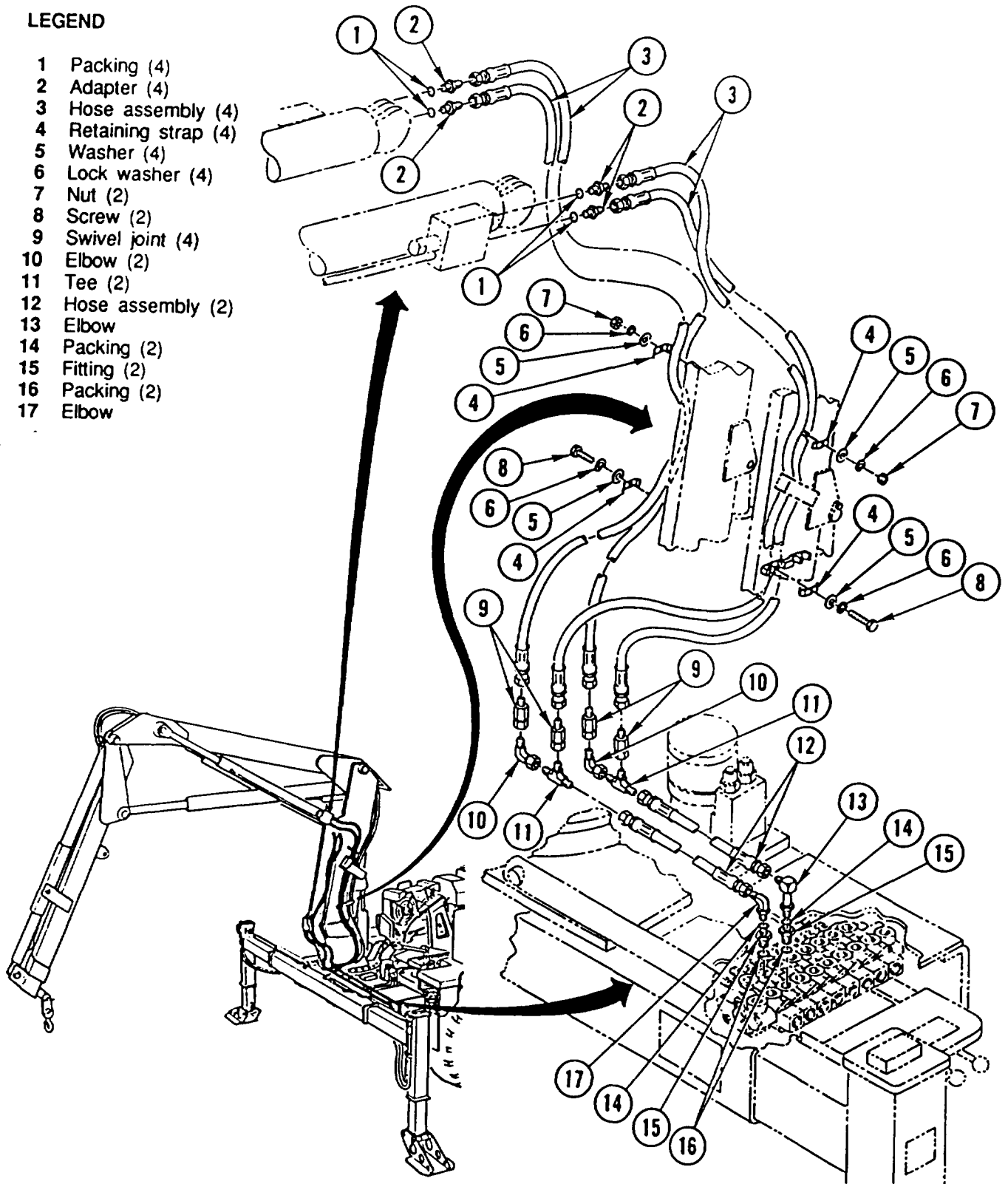

CRANE MAST LOCKING CYLINDER HYDRAULIC LINES AND FITTINGS REPLACEMENT

This task covers: a. Removal b. Installation

INITIAL SETUP

Applicable Configuration:

HMMH

Tools and Special Equipment:

Shop Equipment, SC4910-95-CL-A74
Tool Kit, SC 5180-90-CL-N26

Materials/Parts:

Packing (AR)

Caps and Plugs Appendix C, Item 7

Rags Appendix C, Item 32

Equipment Condition:

Reference

Page 2-23

Condition Description

Crane in Three-Point
Stance

Page 2-23

Hydraulic Pressure
Relieved

General Safety Instructions:

WARNING

High pressure hydraulics [oil under 2450 psi (16,893 kPa)] operate this equipment. Never disconnect any hydraulic line or fitting without first dropping pressure to zero. A high pressure oil stream can pierce body and cause severe injury to personnel.

Fuel and oil are slippery and can cause falls. To avoid injury, wipe up spilled fuel or oil with rags.

REMOVAL

CAUTION

Cap or plug all ports and ends of hoses and tubes to prevent contamination of hydraulic oil. Failure to do so may result in damage to equipment.

NOTE

- Tag lines prior to removal to aid in installation.
- Discard packing(s).

REMOVE crane mast locking cylinder hydraulic LINES and FITTINGS using illustration and legend as a guide.

INSTALLATION

NOTE

Install new packing(s).

INSTALL crane mast locking cylinder hydraulic LINES and FITTINGS using illustration and legend as a guide.

CRANE MAST LOCKING CYLINDER HYDRAULIC LINES AND FITTINGS REPLACEMENT (CONT)

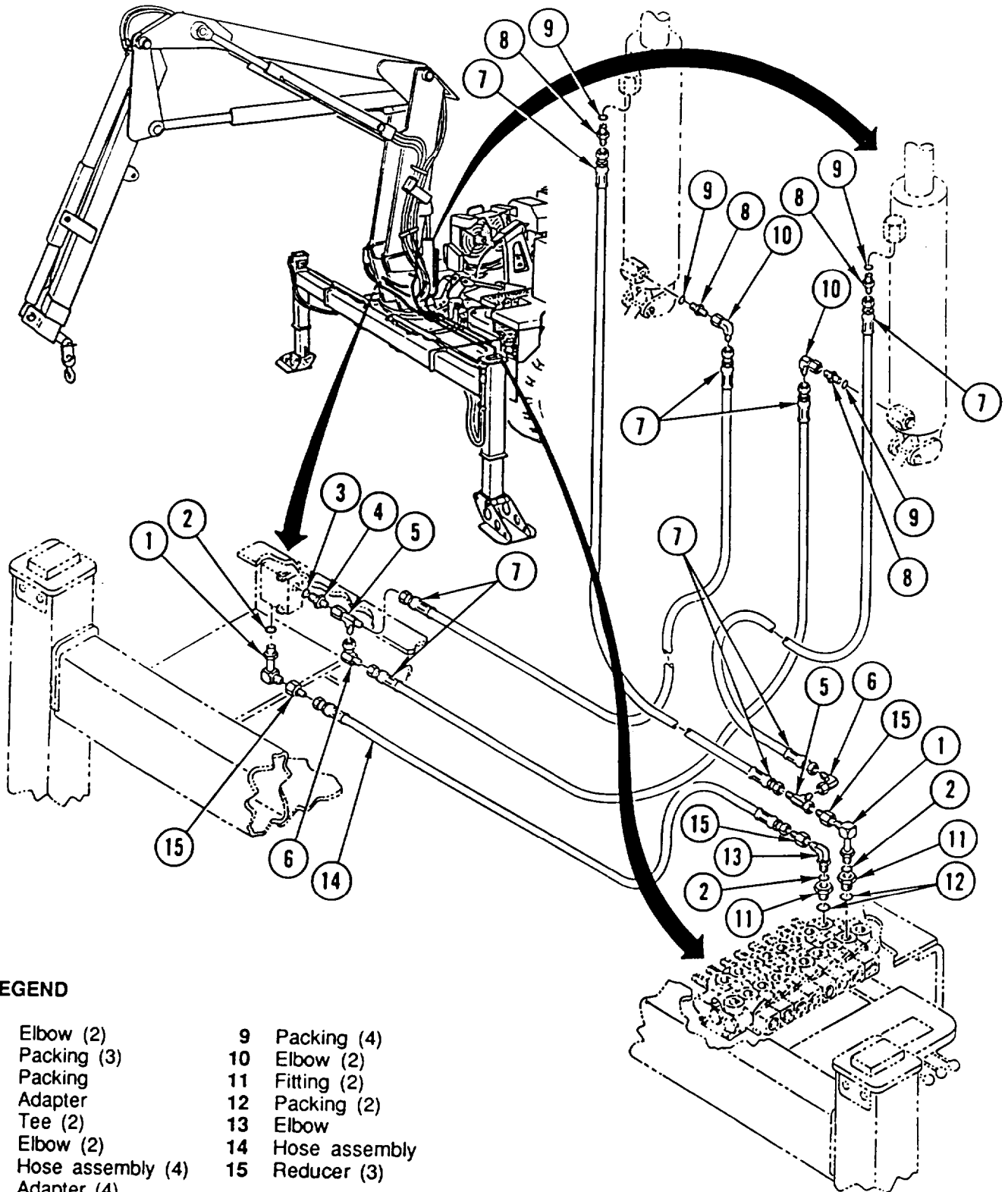

LEGEND

- | | |
|---------------------|------------------|
| 1 Elbow (2) | 9 Packing (4) |
| 2 Packing (3) | 10 Elbow (2) |
| 3 Packing | 11 Fitting (2) |
| 4 Adapter | 12 Packing (2) |
| 5 Tee (2) | 13 Elbow |
| 6 Elbow (2) | 14 Hose assembly |
| 7 Hose assembly (4) | 15 Reducer (3) |
| 8 Adapter (4) | |

CRANE SUPPLY LINES AND FITTINGS REPLACEMENT

This task covers: a. Removal b. Installation

INITIAL SETUP

Applicable Configuration:

HMMH

Tools and Special Equipment:

Shop Equipment, SC 4910-95-CL-A74
Tool Kit, SC 5180-90-CL-N26

Materials/Parts:

Packing (AR)

Caps and Plugs Appendix C, Item 7

Rags Appendix C, Item 32

Equipment Condition:

Reference	Condition Description
Page 2-23	Crane in Three-Point Stance
Page 2-23	Hydraulic Pressure Relieved

General Safety Instructions:

WARNING

High pressure hydraulics [oil under 2450 psi (16,893 kPa)] operate this equipment. Never disconnect any hydraulic line or fitting without first dropping pressure to zero. A high pressure oil stream can pierce body and cause severe injury to personnel.

Fuel and oil are slippery and can cause falls. To avoid injury, wipe up spilled fuel or oil with rags.

REMOVAL

CAUTION

Cap or plug all ports and ends of hoses and tubes to prevent contamination of hydraulic oil. Failure to do so may result in damage to equipment.

NOTE

- Tag lines prior to removal to aid in installation.
- Discard packing(s).

REMOVE crane supply LINES and FITTINGS using illustration and legend as a guide.

INSTALLATION

NOTE

Install new packing(s).

INSTALL crane supply LINES and FITTINGS using illustration and legend as a guide.

CRANE SUPPLY LINES AND FITTINGS REPLACEMENT (CONT)

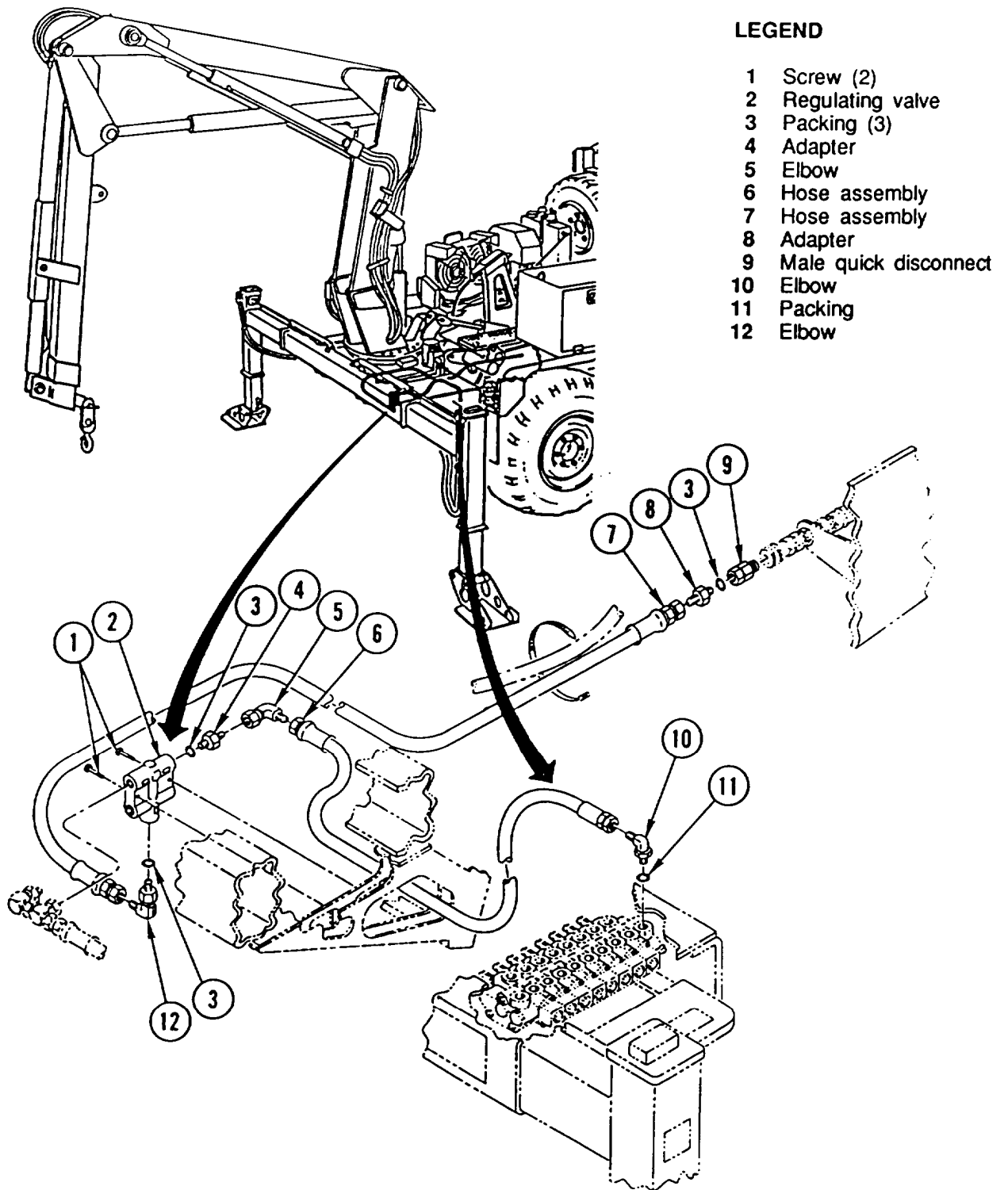

CRANE RETURN LINES AND FITTINGS REPLACEMENT

This task covers: a. Removal b. Installation

INITIAL SETUP

Applicable Configuration:

HMMH

Tools and Special Equipment:

Shop Equipment, SC 4910-95-CL-A74
Tool Kit, SC 5180-90-CL-N26

Materials/Parts:

Packing (AR)

Caps and Plugs Appendix C, Item 7

Rags Appendix C, Item 32

Equipment Condition:

Reference	Condition Description
Page 2-23	Crane in Three-Point Stance
Page 2-23	Hydraulic Pressure Relieved

General Safety Instructions:

WARNING

- High pressure hydraulics [oil under 2450 psi (16,893 kPa)] operate this equipment. Never disconnect any hydraulic line or fitting without first dropping pressure to zero. A high pressure oil stream can pierce body and cause severe injury to personnel.
- Fuel and oil are slippery and can cause falls. To avoid injury, wipe up spilled fuel or oil with rags.

REMOVAL

CAUTION

Cap or plug all ports and ends of hoses and tubes to prevent contamination of hydraulic oil. Failure to do so may result in damage to equipment.

NOTE

- Tag lines prior to removal to aid in installation.
- Discard packing(s).

REMOVE crane return LINES and FITTINGS using illustration and legend as a guide.

INSTALLATION

NOTE

Install new packing(s).

INSTALL crane return LINES and FITTINGS using illustration and legend as a guide.

CRANE RETURN LINES AND FITTINGS REPLACEMENT (CONT)

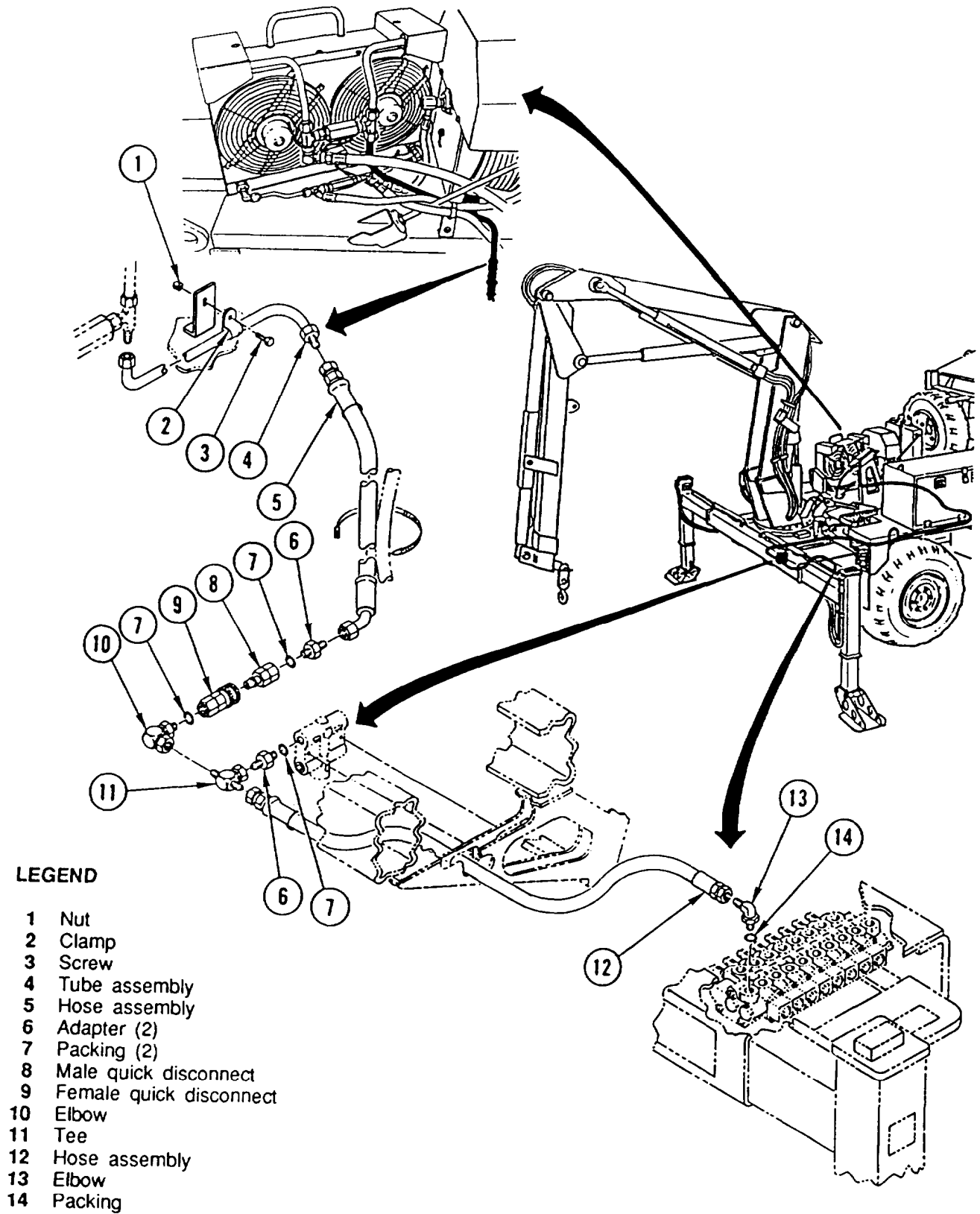

CRANE OUTER BOOM CYLINDER HYDRAULIC LINES AND FITTINGS REPLACEMENT

This task covers: a. Removal b. Installation

INITIAL SETUP

Applicable Configuration:

HMMH

Tools and Special Equipment:

Shop Equipment, SC 4910-95-CL-A74

Tool Kit, SC 5180-90-CL-N26

Materials/Parts:

Packing (AR)

Washer, Lock (AR)

Caps and Plugs Appendix C, Item 7

Rags Appendix C, Item 32

Equipment Condition:

Reference

Page 2-23

Condition Description

Crane in Three-Point Stance

Page 2-23

Hydraulic Pressure Relieved

General Safety Instructions:

WARNING

- High pressure hydraulics [oil under 2450 psi (16,893 kPa)] operate this equipment. Never disconnect any hydraulic line or fitting without first dropping pressure to zero. A high pressure oil stream can pierce body and cause severe injury to personnel.
- Fuel and oil are slippery and can cause falls. To avoid injury, wipe up spilled fuel or oil with rags.

REMOVAL

CAUTION

Cap or plug all ports and ends of hoses and tubes to prevent contamination of hydraulic oil. Failure to do so may result in damage to equipment.

NOTE

- Tag lines prior to removal to aid in installation.
- Discard packing(s) and lock washer(s).

REMOVE crane outer boom cylinder hydraulic LINES and FITTINGS using illustration and legend as a guide.

INSTALLATION

NOTE

Install new packing(s) and new lock washer(s).

INSTALL crane outer boom cylinder hydraulic LINES and FITTINGS using illustration and legend as a guide.

CRANE OUTER BOOM CYLINDER HYDRAULIC LINES AND FITTINGS REPLACEMENT (CONT)

LEGEND

- 1 Packing (2)
- 2 Adapter (2)
- 3 Hose assembly (2)
- 4 Clamp
- 5 Retaining strap (4)
- 6 Washer (4)
- 7 Lock washer (4)
- 8 Nut (2)
- 9 Lock washer
- 10 Screw
- 11 Screw (2)
- 12 Elbow
- 13 Elbow
- 14 Packing (2)
- 15 Fitting (2)
- 16 Packing (2)

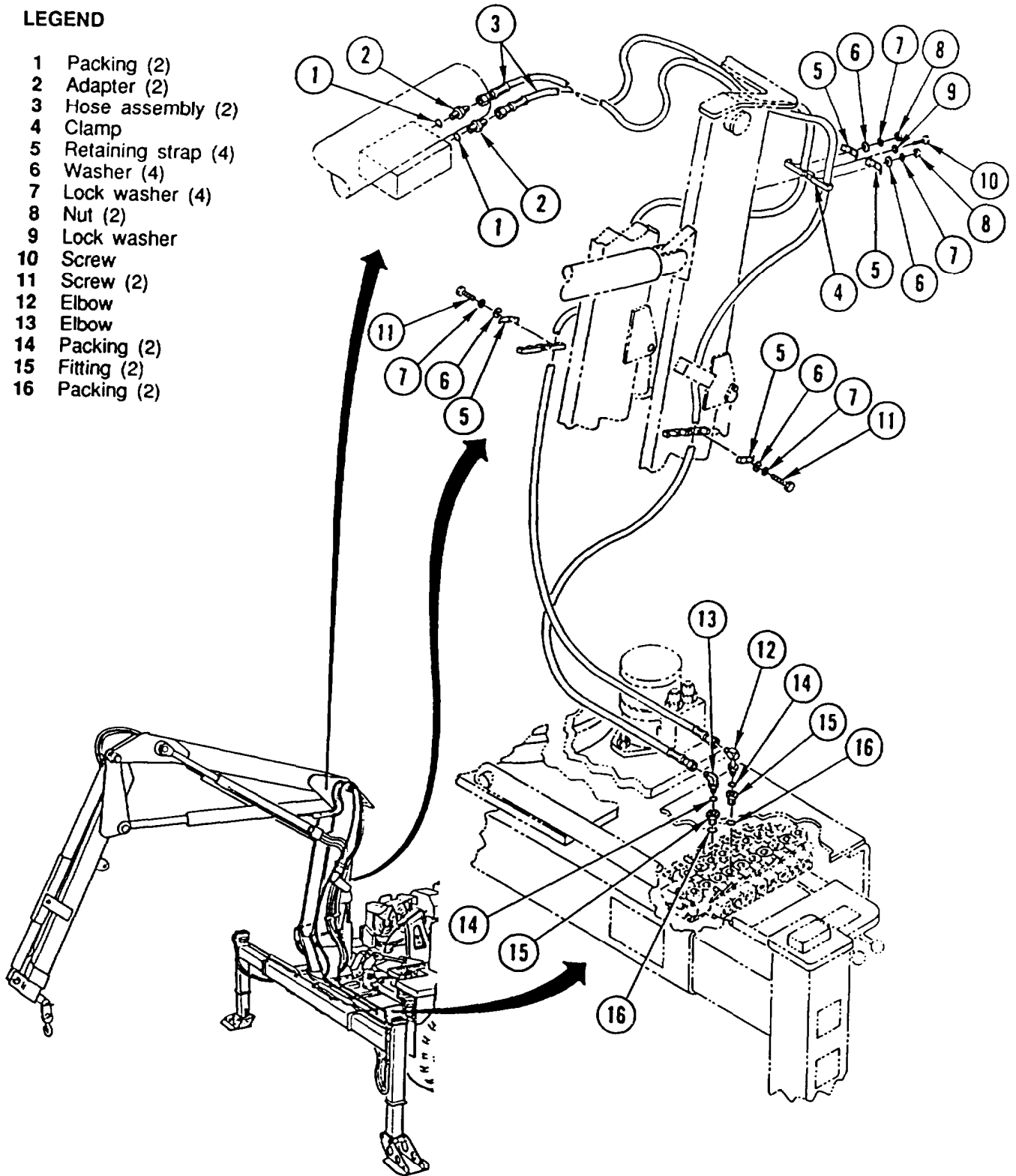

CRANE HORIZONTAL OUTRIGGER CYLINDER HYDRAULIC LINES AND FITTINGS REPLACEMENT

This task covers: a. Removal b. Installation

INITIAL SETUP

Applicable Configuration:

HMMH

Tools and Special Equipment:

Shop Equipment, SC 4910-95-CL-A74
Tool Kit, SC 5180-90-CL-N26

Materials/Parts:

Packing (AR)

Caps and Plugs Appendix C, Item 7

Rags Appendix C, Item 32

Equipment Condition:

Reference	Condition Description
Page 2-23	Crane in Three-Point Stance
Page 2-23	Hydraulic Pressure Relieved

General Safety Instructions:

WARNING

- High pressure hydraulics [oil under 2450 psi (16,893 kPa)] operate this equipment. Never disconnect any hydraulic line or fitting without first dropping pressure to zero. A high pressure oil stream can pierce body and cause severe injury to personnel.
- Fuel and oil are slippery and can cause falls. To avoid injury, wipe up spilled fuel or oil with rags.

REMOVAL

CAUTION

Cap or plug all ports and ends of hoses and tubes to prevent contamination of hydraulic oil. Failure to do so may result in damage to equipment.

NOTE

- Tag lines prior to removal to aid in installation.
- Discard packing(s).

REMOVE crane horizontal outrigger cylinder hydraulic LINES and FITTINGS using illustration and legend as a guide.

INSTALLATION

NOTE

Install new packing(s).

INSTALL crane horizontal outrigger cylinder hydraulic LINES and FITTINGS using illustration and legend as a guide.

CRANE HORIZONTAL OUTRIGGER CYLINDER HYDRAULIC LINES AND FITTINGS REPLACEMENT (CONT)

LEGEND

- 1 Elbow (4)
- 2 Packing (4)
- 3 Hose assembly
- 4 Tee (2)
- 5 Elbow (2)
- 6 Hose assembly
- 7 Hose assembly (3)
- 8 Hose assembly
- 9 Reducer (2)
- 10 Elbow
- 11 Elbow
- 12 Packing (2)
- 13 Fitting (2)
- 14 Packing (2)
- 15 Clamp
- 16 Screw

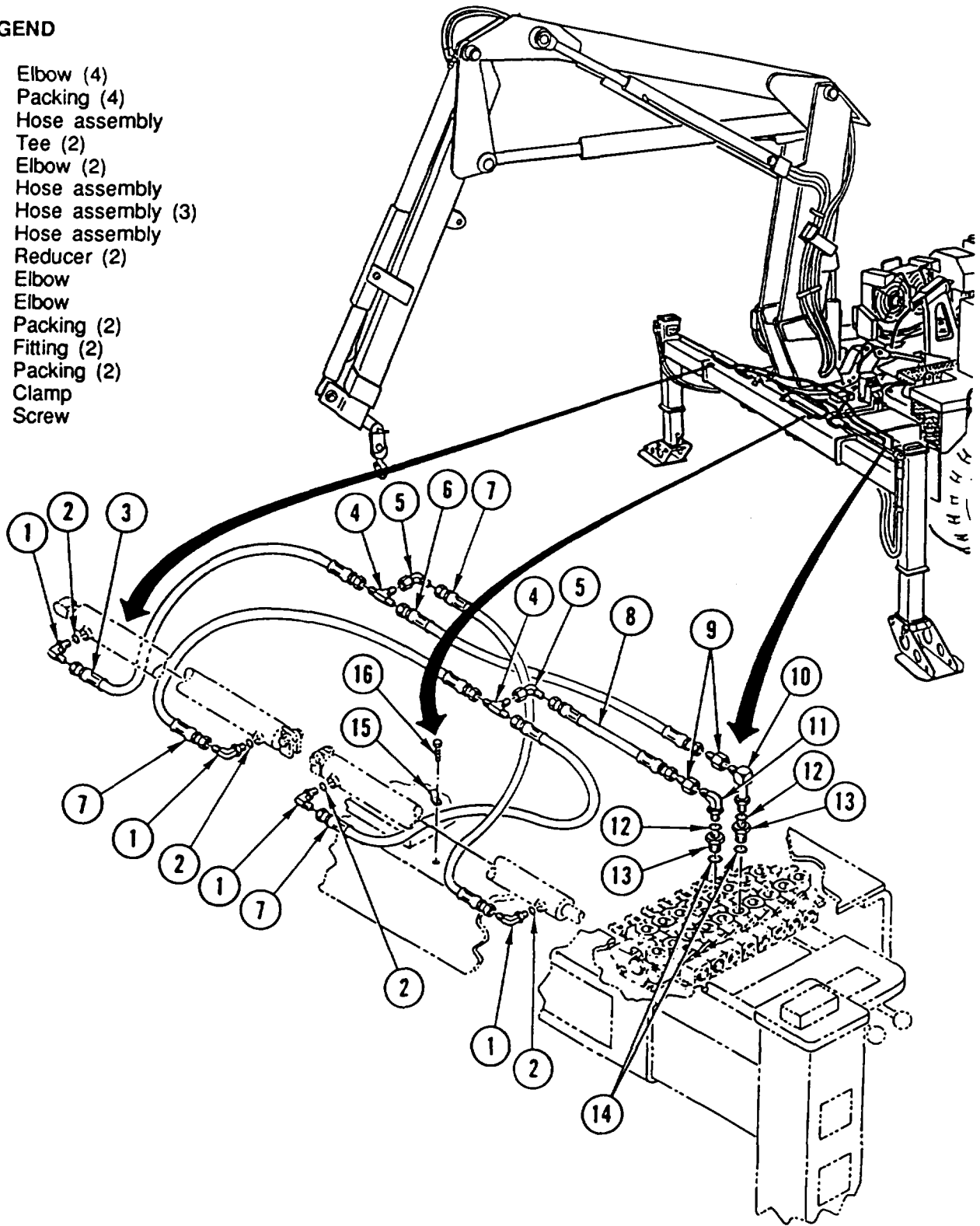

CRANE VERTICAL OUTRIGGER CYLINDER HYDRAULIC LINES AND FITTINGS REPLACEMENT

This task covers: a. Removal b. Installation

INITIAL SETUP

Applicable Configuration:

HMMH

Tools and Special Equipment:

Shop Equipment, SC 4910-95-CL-A74
Tool Kit, SC 5180-90-CL-N26

Materials/Parts:

Nut, Lock (AR)

Packing (AR)

Caps and Plugs Appendix C, Item 7

Rags Appendix C, Item 32

Equipment Condition:

Reference	Condition Description
-----------	-----------------------

Page 2-23	Crane in Three-Point Stance
-----------	-----------------------------

Page 2-23	Hydraulic Pressure Relieved
-----------	-----------------------------

General Safety Instructions:

WARNING

- High pressure hydraulics [oil under 2450 psi (16,893 kPa)] operate this equipment. Never disconnect any hydraulic line or fitting without first dropping pressure to zero. A high pressure oil stream can pierce body and cause severe injury to personnel.
- Fuel and oil are slippery and can cause falls. To avoid injury, wipe up spilled fuel or oil with rags.

REMOVAL

CAUTION

Cap or plug all ports and ends of hoses and tubes to prevent contamination of hydraulic oil. Failure to do so may result in damage to equipment.

NOTE

- Tag lines prior to removal to aid in installation.
- Discard lock nut(s) and packing(s).

REMOVE crane vertical outrigger cylinder hydraulic LINES and FITTINGS using illustration and legend as a guide.

INSTALLATION

NOTE

Install new lock nut(s) and new packing(s).

INSTALL crane vertical outrigger cylinder hydraulic LINES and FITTINGS using illustration and legend as a guide.

CRANE VERTICAL OUTRIGGER CYLINDER HYDRAULIC LINES AND FITTINGS REPLACEMENT (CONT)

LEGEND

- 1 Lock nut (5)
- 2 Retaining strap (5)
- 3 Hose assembly (2)
- 4 Elbow (6)
- 5 Packing (8)
- 6 Elbow (2)
- 7 Fitting (4)
- 8 Packing (4)
- 9 Hose assembly (2)

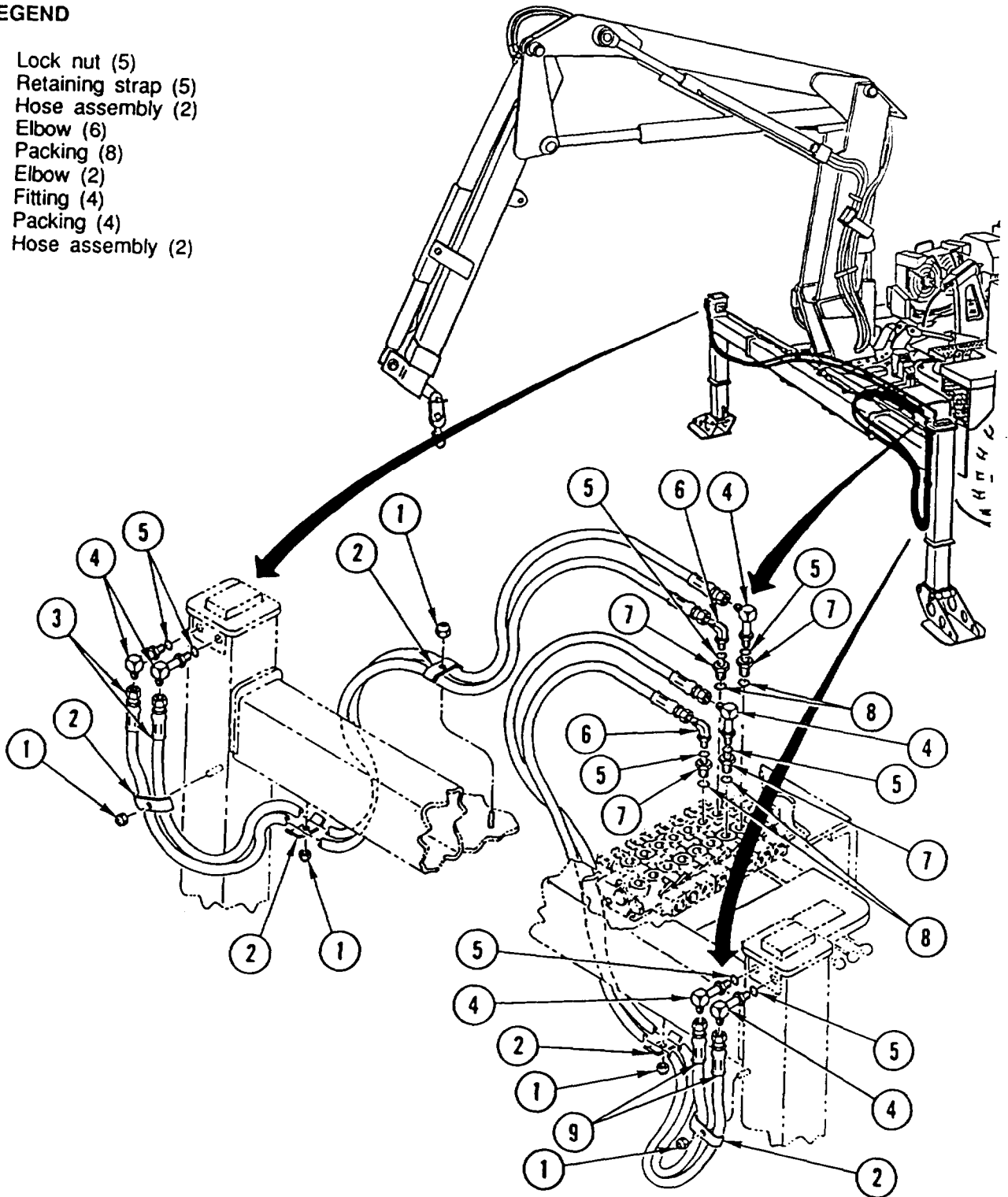

HYDRAULIC SUSPENSION LOCKOUT LINES AND FITTINGS REPLACEMENT

This task covers: a. Removal b. Installation

INITIAL SETUP

Applicable Configuration:

HMMH

Tools and Special Equipment:

Shop Equipment, SC 4910-95-CL-A74
Tool Kit, SC 5180-90-CL-N26

Materials/Parts:

Seal (AR)

Caps and Plugs Appendix C, Item 7

Rags Appendix C, Item 32

References:

TM 5-2420-224-10

Equipment Condition:

Reference	Condition Description
TM 5-2420-224-10	Suspension Lockout System Disengaged

General Safety Instructions:

WARNING

- High pressure hydraulics [oil under 2450 psi (16,893 kPa)] operate this equipment. Never disconnect any hydraulic line or fitting without first dropping pressure to zero. A high pressure oil stream can pierce body and cause severe injury to personnel.
- Fuel and oil are slippery and can cause falls. To avoid injury, wipe up spilled fuel or oil with rags.

REMOVAL

CAUTION

Cap or plug all ports and ends of hoses and tubes to prevent contamination of hydraulic oil. Failure to do so may result in damage to equipment.

NOTE

Ž Tag lines prior to removal to aid in installation.

- Discard seal(s).

REMOVE hydraulic suspension lockout LINES and FITTINGS using illustration and legend as a guide.

INSTALLATION

NOTE

Install new seal(s).

INSTALL hydraulic suspension lockout LINES and FITTINGS using illustration and legend as a guide.

**HYDRAULIC SUSPENSION LOCKOUT LINES AND FITTINGS
REPLACEMENT (CONT)**

LEGEND

- | | |
|--------------------------|---------------------------|
| 1 Fluid passage bolt (2) | 11 Tee (2) |
| 2 Seal (4) | 12 Hose |
| 3 Connector (4) | 13 Fluid passage bolt (2) |
| 4 Washer (6) | 14 Hose assembly (2) |
| 5 Spacer (2) | 15 Hose assembly |
| 6 Adapter (4) | 16 Hose |
| 7 Ferrule (11) | 17 Clamp (3) |
| 8 Union nut (11) | 18 Hose clamp (3) |
| 9 Hose | 19 Hose (2) |
| 10 Washer (2) | |

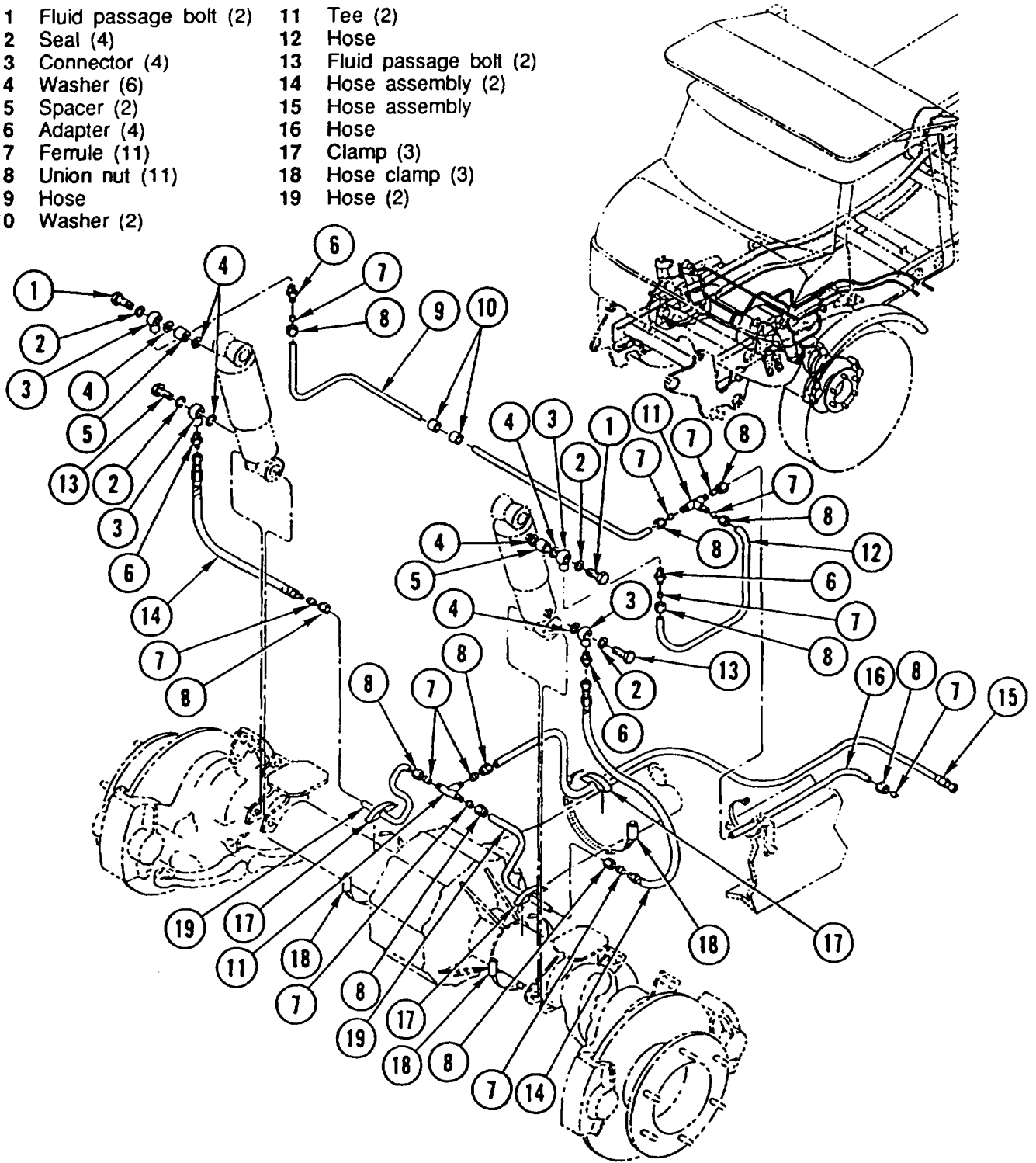

HYDRAULIC SUSPENSION LOCKOUT PUMP AND RESERVOIR LINES AND FITTINGS REPLACEMENT

This task covers: a. Removal b. Installation

INITIAL SETUP

Applicable Configuration:

HMMH

Tools and Special Equipment:

Shop Equipment, SC 4910-95-CL-A74
Tool Kit, SC 5180-90-CL-N26

Materials/Parts:

Packing (AR)

Caps and Plugs Appendix C, Item 7

Rags Appendix C, item 32

References:

TM 5-2420-224-10

Equipment Condition:

Reference	Condition Description
TM 5-2420-224-10	Suspension Lockout System Disengaged

General Safety Instructions:

WARNING

- High pressure hydraulics [oil under 2450 psi (16,893 kPa)] operate this equipment. Never disconnect any hydraulic line or fitting without first dropping pressure to zero. A high pressure oil stream can pierce body and cause severe injury to personnel.
- Fuel and oil are slippery and can cause falls. To avoid injury, wipe up spilled fuel or oil with rags.

REMOVAL

CAUTION

Cap or plug all ports and ends of hoses and tubes to prevent contamination of hydraulic oil. Failure to do so may result in damage to equipment.

NOTE

- Tag lines prior to removal to aid in installation.
- Discard packing(s).

REMOVE hydraulic suspension lockout pump and reservoir LINES and FITTINGS using illustration and legend as a guide.

INSTALLATION

NOTE

Install new packing(s).

INSTALL hydraulic suspension lockout pump and reservoir LINES and FITTINGS using illustration and legend as a guide.

HYDRAULIC SUSPENSION LOCKOUT PUMP AND RESERVOIR LINES AND FITTINGS REPLACEMENT (CONT)

LEGEND

- | | | | |
|---|--------------------|----|--------------------|
| 1 | Fluid passage bolt | 9 | Fluid passage bolt |
| 2 | Packing (9) | 10 | Adapter |
| 3 | Hose assembly | 11 | Check valve (2) |
| 4 | Fluid passage bolt | 12 | Hose assembly |
| 5 | Connector | 13 | Adapter |
| 6 | Hose | 14 | Hose assembly |
| 7 | Fluid passage bolt | 15 | Connector |
| 8 | Connector | 16 | Connector |

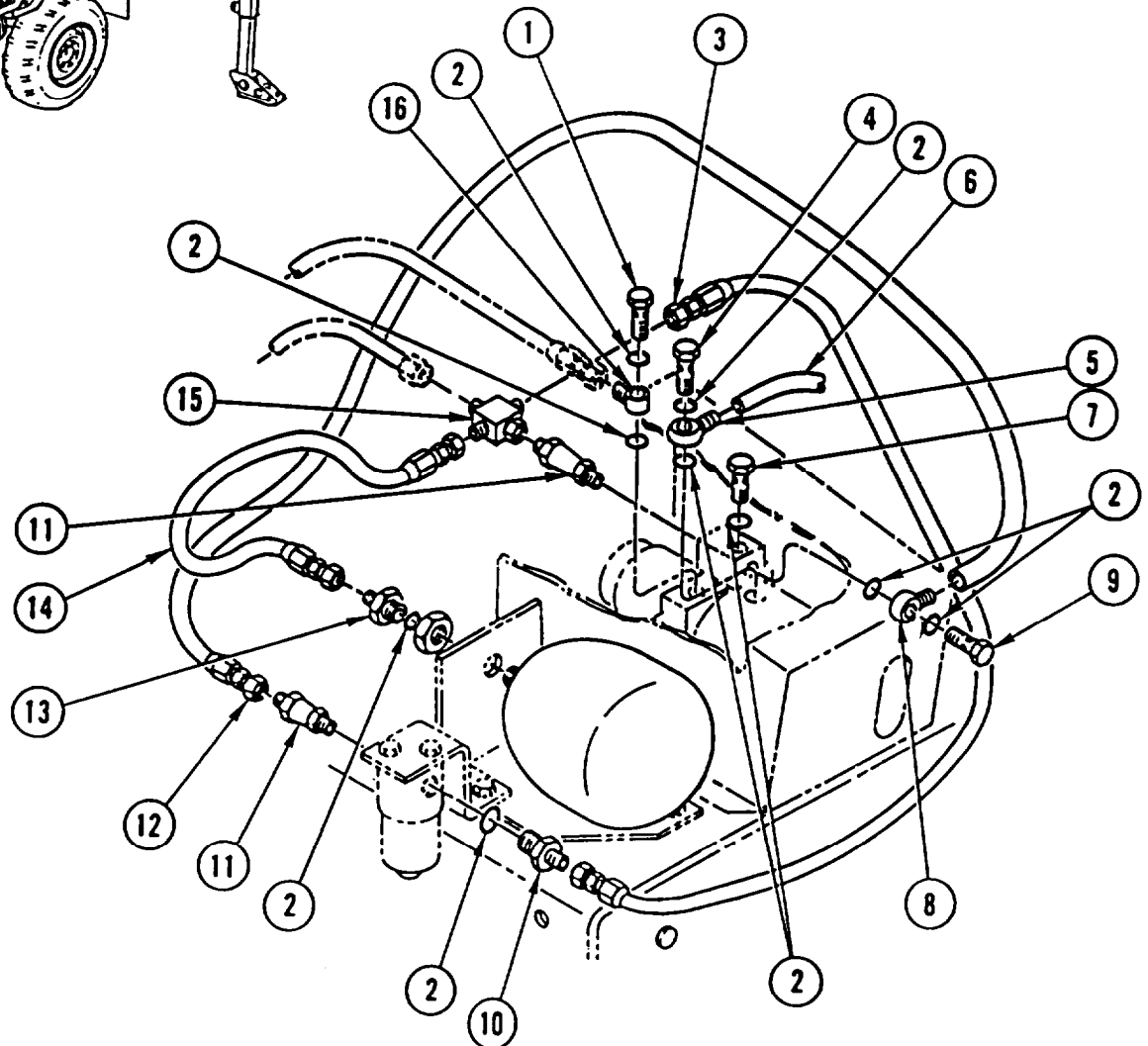
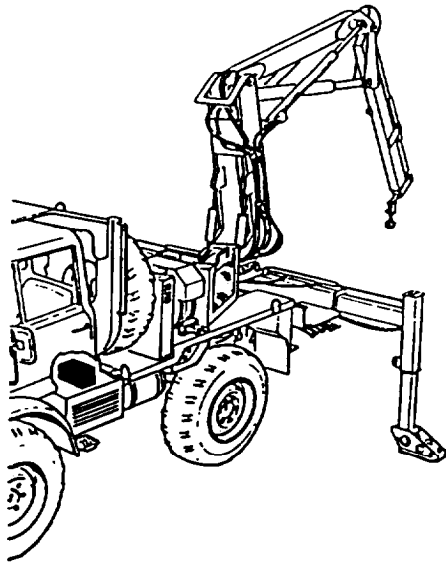

LOADER BOOM CYLINDER REPLACEMENT

This task covers: a. Removal b. Installation

INITIAL SETUP

Applicable Configuration:

SEE

Tools and Special Equipment:

Shop Equipment, SC 4910-95-CL-A74

Tool Kit, SC 5180-90-CL-N26

Materials/Parts:

Washer, Lock (2)

Caps and Plugs Appendix C, Item 7

Rags Appendix C, Item 32

Personnel Required: (2)

References:

TM 5-2420-224-10

Equipment Condition:

Reference

Condition Description

TM 5-2420-224-10

Loader Bucket Lowered to Ground

Page 2-23

Hydraulic Pressure Relieved

General Safety Instructions:

WARNING

- High pressure hydraulics [oil under 2450 psi (16,893 kPa)] operate this equipment. Never disconnect any hydraulic line or fitting without first dropping pressure to zero. A high pressure oil stream can pierce body and cause severe injury to personnel.
- Loader boom cylinder weighs 83 pounds (38 kilograms). To avoid personal injury, use a hoist or suitable lifting device when lifting loader boom cylinder.
- Fuel and oil are slippery and can cause falls. To avoid injury, wipe up spilled fuel or oil with rags.

REMOVAL

CAUTION

Cap or plug all ports and ends of hoses and tubes to prevent contamination of hydraulic oil. Failure to do so may result in damage to equipment.

NOTE

- Procedure is the same for both boom cylinders.
- Tag all lines prior to removal to aid in installation.

1. DISCONNECT two HOSES (1 and 2). INSTALL CAPS or PLUGS.

LOADER BOOM CYLINDER REPLACEMENT (CONT)

- REMOVE bolt (3), lock washer (4), washer (5), and PIN (6) from each end of boom cylinder (7). REMOVE boom CYLINDER (7). DISCARD lock WASHERS.
- REMOVE two clamps (8 and 9), two TUBES (10 and 11), and two fittings (12 and 13).

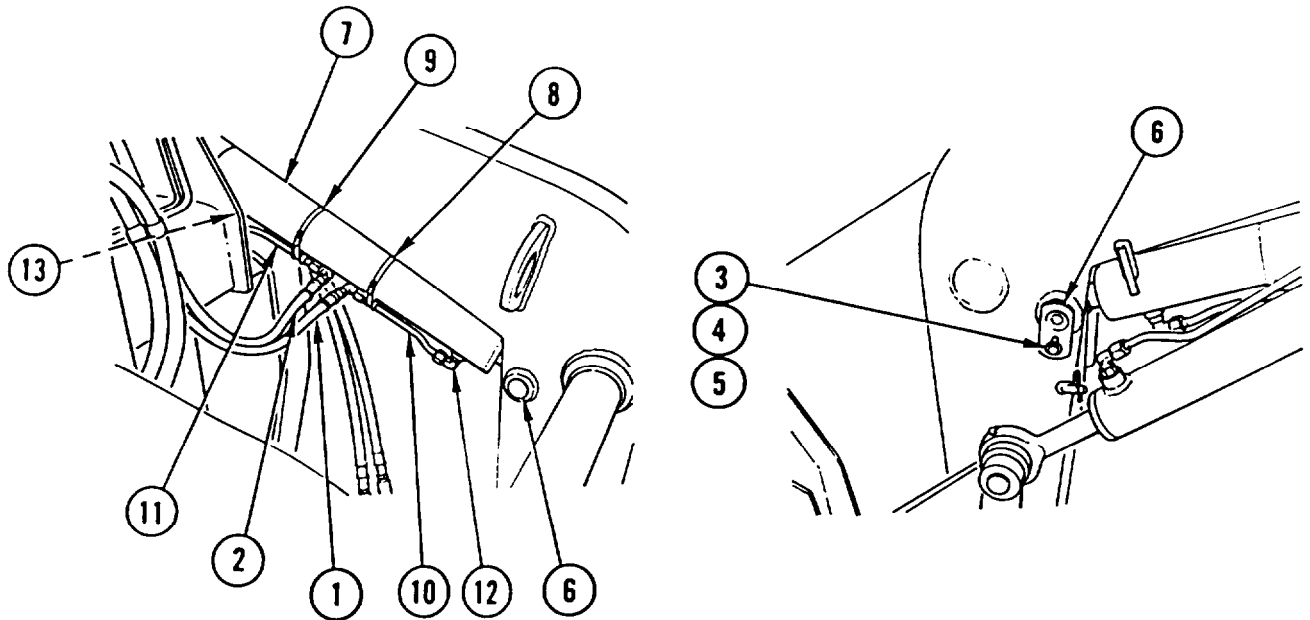

INSTALLATION

NOTE

Procedure is the same for both boom cylinders.

- INSTALL two fittings (12 and 13), two TUBES (10 and 11), and two clamps (8 and 9).
- INSTALL boom CYLINDER (7). INSTALL PIN (6), washer (5), new lock washer (4), and bolt (3) in each end of boom cylinder (7).
- REMOVE CAPS or PLUGS. CONNECT two HOSES (1 and 2).

NOTE

Follow-on Maintenance:
Check front hydraulic tank (TM 5-2420-224-10).

LOADER BUCKET ROLLBACK CYLINDER REPLACEMENT

This task covers: a Removal b. Installation

INITIAL SETUP

Applicable Configuration:

SEE

Tools and Special Equipment:

Shop Equipment, SC 4910-95-CL-A74
Tool Kit, SC 5180-90-CL-N26

Materials/Parts:

Pin, Cotter

Caps and Plugs Appendix C, Item 7

Rags Appendix C, item 32

Personnel Required: (2)

References:

TM 5-2420-224-10

Equipment Condition:

Reference	Condition Description
TM 5-2420-224-10	Loader in Transport Position
TM 5-2420-224-10	Loader Bucket Lowered to Ground
Page 2-23	Hydraulic Pressure Relieved

General Safety Instructions:

WARNING

- High pressure hydraulics [oil under 2450 psi (16,893 kPa)] operate this equipment. Never disconnect any hydraulic line or fitting without first dropping pressure to zero. A high pressure oil stream can pierce body and cause severe injury to personnel.
- Loader bucket rollback cylinder weighs 40 pounds (18 kilograms). To avoid personal injury, use a hoist or suitable lifting device when lifting loader bucket rollback cylinder.
- Fuel and oil are slippery and can cause falls. To avoid injury, wipe up spilled fuel or oil with rags.

REMOVAL

CAUTION

Cap or plug all ports and ends of hoses and tubes to prevent contamination of hydraulic oil. Failure to do so may result in damage to equipment.

NOTE

- Procedure is the same for both rollback cylinders.
 - Tag lines prior to disconnecting to aid in connecting.
1. DISCONNECT two HOSES (1 and 2). INSTALL CAPS or PLUGS.

LOADER BUCKET ROLLBACK CYLINDER REPLACEMENT (CONT)

2. REMOVE cotter pin (3), castellated nut (4), and SPACER (5). DISCARD cotter PIN.
3. REMOVE roll pin (6), pin (7), and rollback CYLINDER (8).
4. REMOVE clamp (9) and SADDLE (10) from rollback cylinder (8).
5. REMOVE TUBE (11) and two fittings (12 and 13).

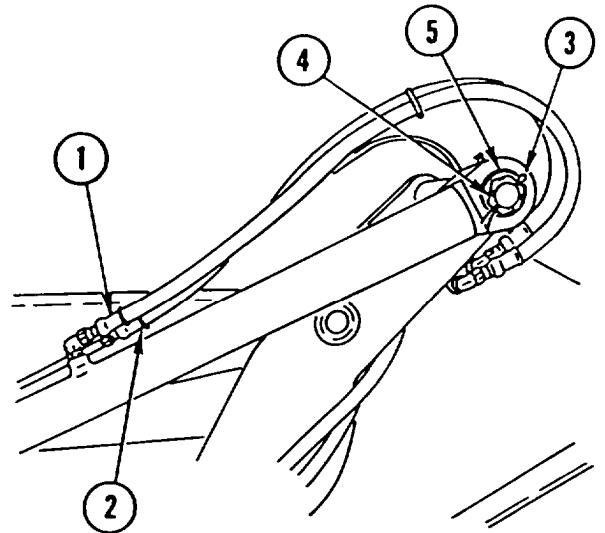

INSTALLATION

NOTE

Procedure is the same for both rollback cylinders.

1. INSTALL two fittings (12 and 13) and TUBE (11).
2. INSTALL SADDLE (10) and clamp (9) on rollback cylinder (8).
3. INSTALL rollback CYLINDER (8), pin (7), and roll pin (6).
4. INSTALL SPACER (5), castellated nut (4), and new cotter pin (3).
5. REMOVE CAPS or PLUGS. CONNECT two HOSES (1 and 2).

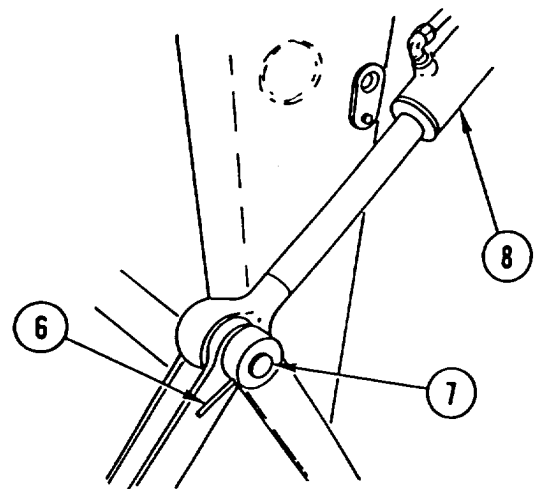

NOTE

Follow-on Maintenance:
Check front hydraulic tank (TM 5-2420-224-10).

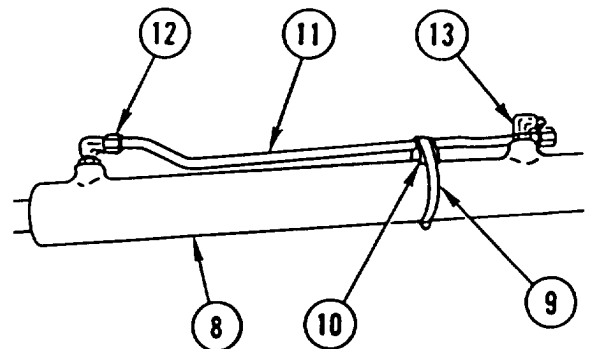

BACKHOE BOOM CYLINDER REPLACEMENT

This task covers: a. Removal b. Installation

INITIAL SETUP

Applicable Configuration:

SEE

Tools and Special Equipment:

Shop Equipment, SC 4910-95-CL-A74
Tool Kit, SC 5180-90-CL-N26

Materials/Parts:

Packing

Packing

Washer, Lock

Caps and Plugs Appendix C, Item 7

Rags Appendix C, Item 32

Personnel Required: (2)

References:

TM 5-2420-224-10

Equipment Condition:

Reference	Condition Description
Page 2-22	Backhoe in Three-Point Stance
Page 2-23	Hydraulic Pressure Relieved

General Safety Instructions:

WARNING

- High pressure hydraulics [oil under 2450 psi (16,893 kPa)] operate this equipment. Never disconnect any hydraulic line or fitting without first dropping pressure to zero. A high pressure oil stream can pierce body and cause severe injury to personnel.
- Backhoe boom cylinder weighs 83 pounds (38 kilograms). To avoid personal injury, use a hoist or suitable lifting device when lifting backhoe boom cylinder.
- Fuel and oil are slippery and can cause falls. To avoid injury, wipe up spilled fuel or oil with rags.

REMOVAL

NOTE

Procedure is the same for both boom cylinders, except as noted.

1. REMOVE two snap RINGS (1) and two washers (2).

NOTE

Quantity of washers may vary from zero to several.

2. SLIDE rod EYE off rod (3) and REMOVE WASHER(S) (4).
3. REMOVE nut (5) and CAPSCREW (6).

BACKHOE BOOM CYLINDER REPLACEMENT (CONT)

CAUTION

Cap or plug all ports and ends of hoses and tubes to prevent contamination of hydraulic oil. Failure to do so may result in damage to equipment.

NOTE

Tag lines prior to disconnecting to aid in connecting.

4. DISCONNECT three HOSES (7, 8, and 9). INSTALL CAPS or PLUGS.
5. REMOVE clamp (10), TUBE (11), two fittings (12 and 13), and two packings (14 and 15). DISCARD PACKINGS.
6. ON LEFT SIDE, REMOVE nut (16), lock washer (17), screw (18), spacer (19), and retainer STRAP (20). DISCARD lock WASHER.
7. REMOVE pin (21) and boom CYLINDER (22).

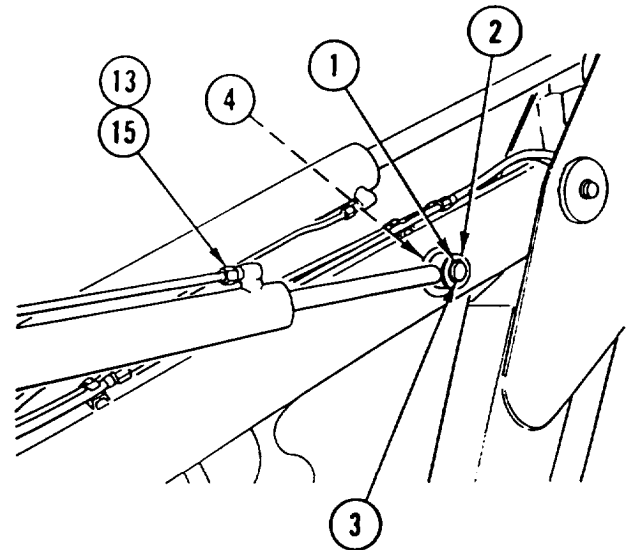

INSTALLATION

NOTE

Procedure is the same for both boom cylinders, except as noted.

1. INSTALL boom CYLINDER (22) and pin (21).
2. INSTALL two fittings (12 and 13), two new packings (14 and 15), TUBE (11), and clamp (10).
3. ON LEFT SIDE, INSTALL retainer STRAP (20), screw (18), spacer (19), new lock washer (17), and nut (16).
4. REMOVE CAPS or PLUGS. CONNECT three HOSES (7, 8, and 9).
5. INSTALL CAPSCREW (6) and nut (5).
6. INSTALL WASHER(S) (4) as required to maintain 0.040-in. (1-mm) clearance. INSTALL rod EYE on rod (3).
7. INSTALL two washers (2) and two snap RINGS (1).

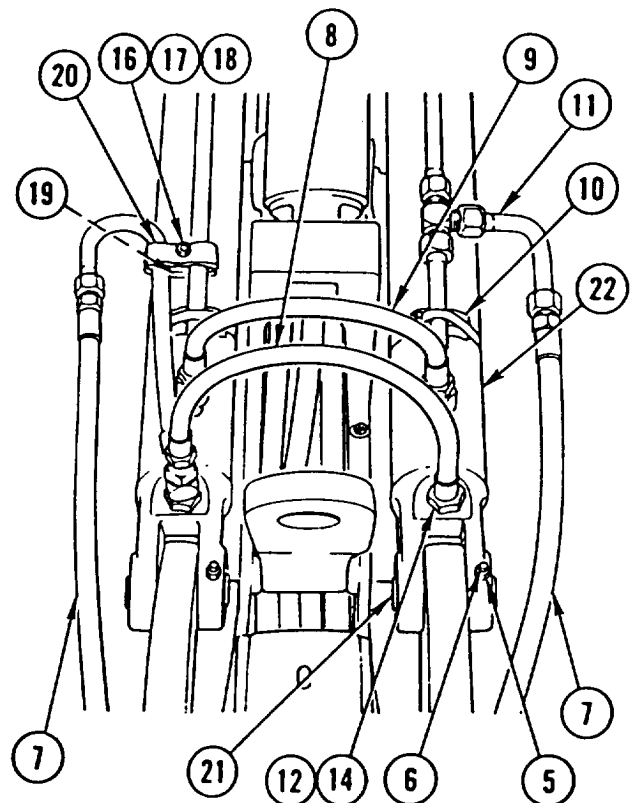

NOTE

Follow-on Maintenance:

Check rear hydraulic tank (TM 5-2420-224-10).

BACKHOE SWING CYLINDER REPLACEMENT

This task covers: a. Removal b. Installation

INITIAL SETUP

Applicable Configuration:

SEE

Tools and Special Equipment:

Shop Equipment, SC 4910-95-CL-A74
 Tool Kit, SC 5180-90-CL-N26

Material/Parts:

Packing (3)

Packing (2)

Caps and Plugs Appendix C, Item 7

Rags Appendix C, Item 32

Personnel Required: (2)

References:

TM 5-2420-224-10

Equipment Condition:

Reference	Condition Description
Page 2-22	Backhoe in Three-Point Stance
Page 2-23	Hydraulic Pressure Relieved

General Safety Instructions:

WARNING

- High pressure hydraulics [oil under 2450 psi (16,893 kPa)] operate this equipment. Never disconnect any hydraulic line or fitting without first dropping pressure to zero. A high pressure oil stream can pierce body and cause severe injury to personnel.
- Backhoe swing cylinder weighs 70 pounds (32 kilograms). To avoid personal injury, use a hoist or suitable lifting device when lifting backhoe swing cylinder.
- Fuel and oil are slippery and can cause falls. To avoid injury, wipe up spilled fuel or oil with rags.

REMOVAL

NOTE

- Procedure is the same for both swing cylinders except as noted.
- Place backhoe in three-point stance that will bring boom low enough to allow access to inner swing tower.
- Backhoe must be swung to opposite side from which swing cylinder is removed.

1. REMOVE retaining RING (1) and washer (2).

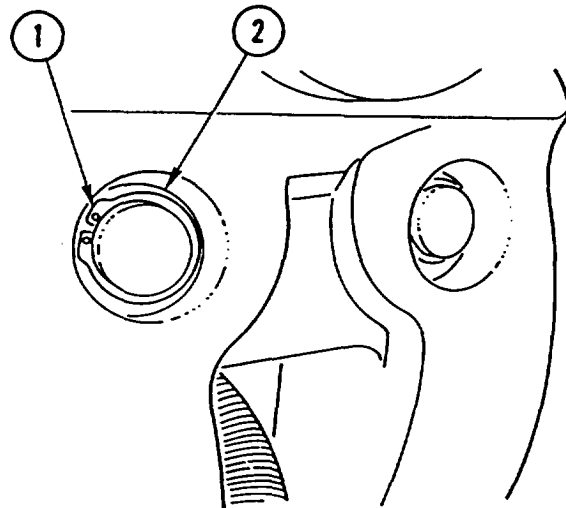

BACKHOE SWING CYLINDER REPLACEMENT (CONT)

2. REMOVE retaining ring (3), washer (4), and PIN (5) from inner swing tower (6).

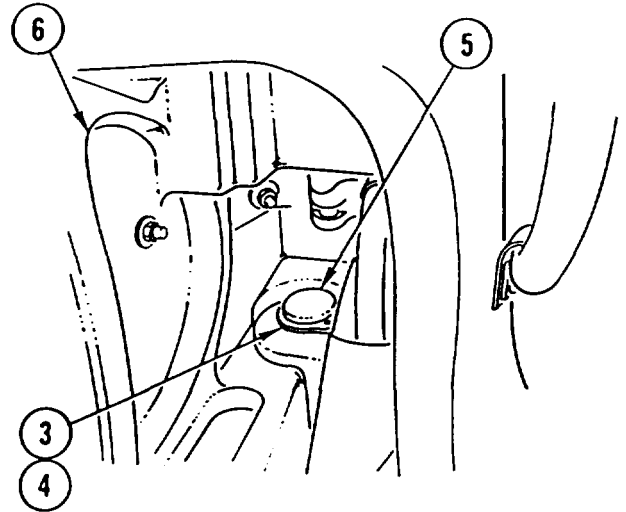

3. HYDRAULICALLY RETRACT swing CYLINDER (7).
4. SWING swing CYLINDER (7) outward from Inner swing tower (6).

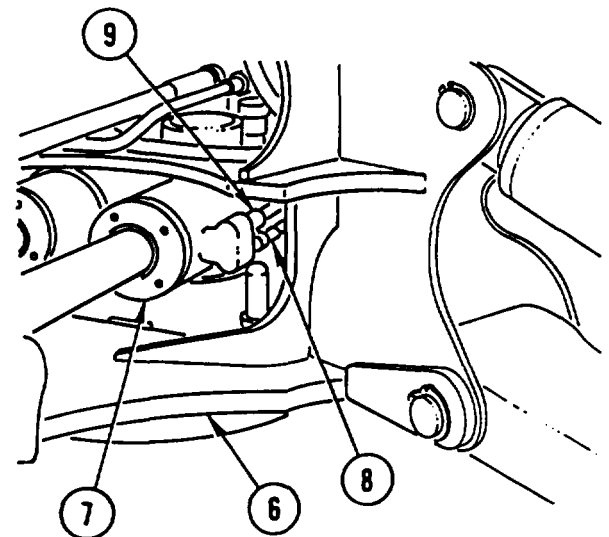
**CAUTION**

Cap or plug all ports and ends of hoses and tubes to prevent contamination of hydraulic oil. Failure to do so may result in damage to equipment.

NOTE

Tag all lines prior to disconnecting to aid in connecting.

5. ON RIGHT swing CYLINDER, DISCONNECT three HOSES (8, 9, and 10). INSTALL CAPS or PLUGS.

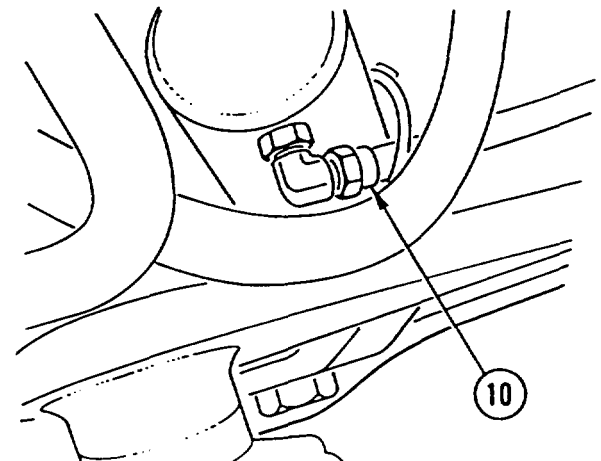

BACKHOE SWING CYLINDER REPLACEMENT (CONT)

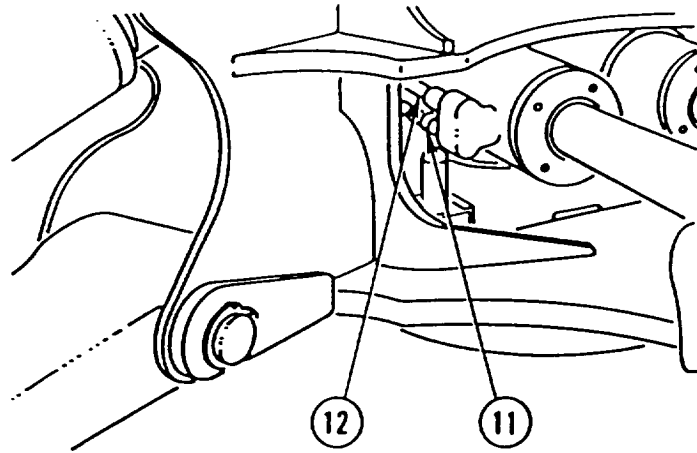

6. ON LEFT swing CYLINDER, DISCONNECT two HOSES (11 and 12). INSTALL CAPS or PLUGS.

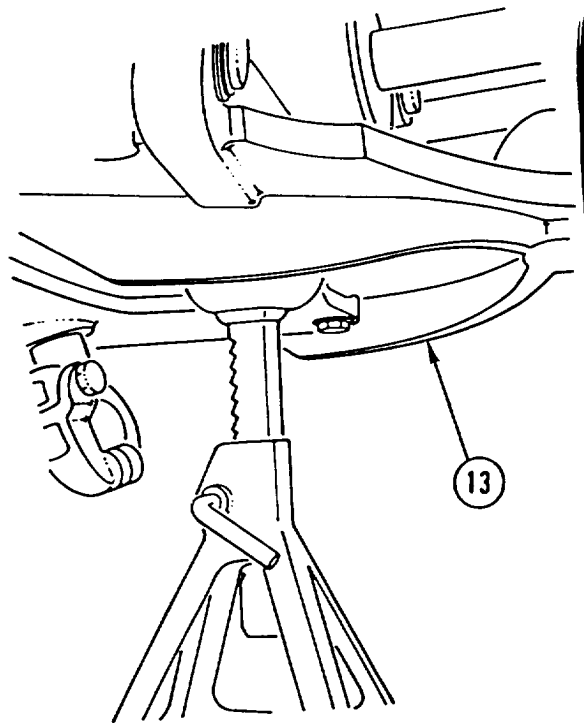

7. PLACE JACK stand under swing beam (13).

BACKHOE SWING CYLINDER REPLACEMENT (CONT)

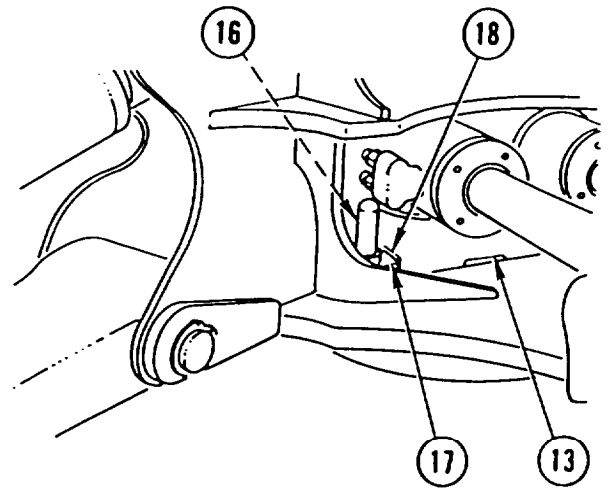
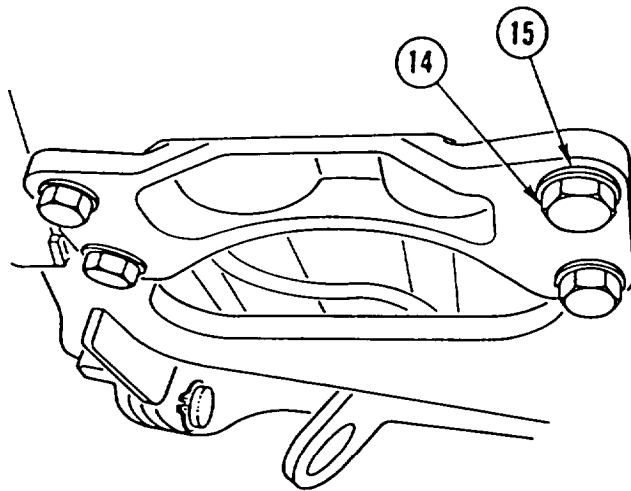

NOTE

Tag screws prior to removal to aid in installation.

8. REMOVE four screws (14), four washers (15), four nuts (16), two grips (17), retainer (18), and swing BEAM (13). REMOVE JACK stand.

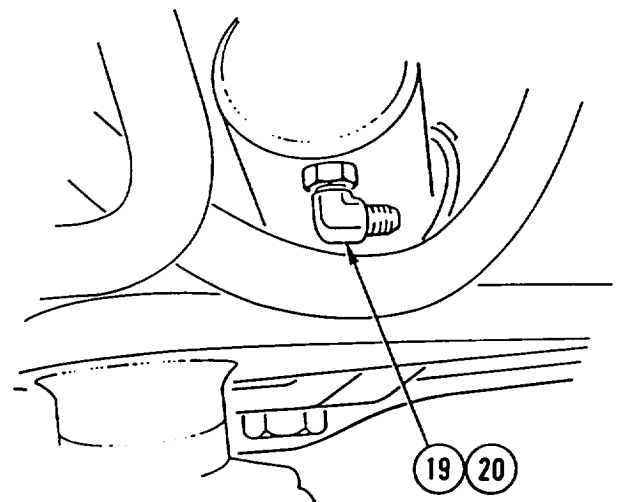
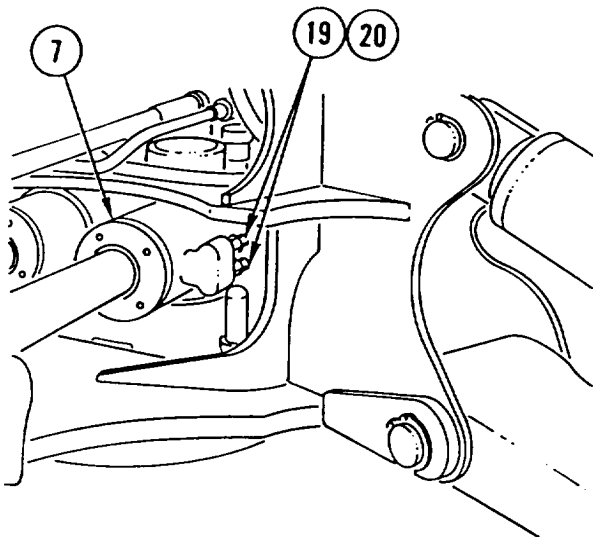

9. REMOVE swing CYLINDER (7).
10. ON RIGHT swing CYLINDER, REMOVE three FITTINGS (19) and three packings (20). INSTALL CAPS or PLUGS. DISCARD PACKINGS.

BACKHOE SWING CYLINDER REPLACEMENT (CONT)

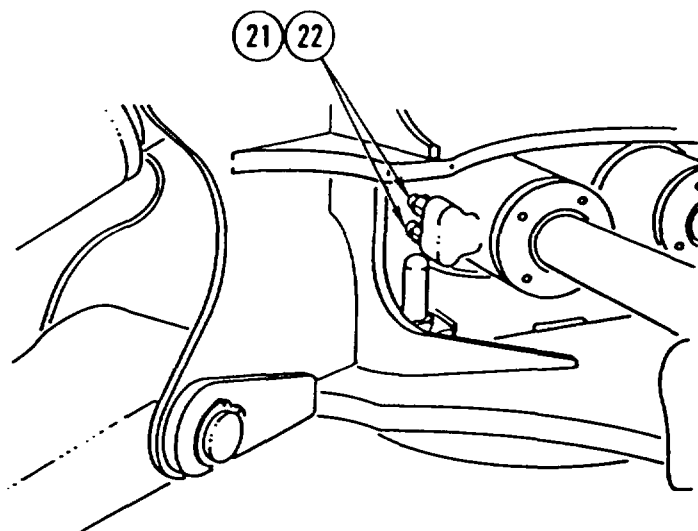

11. ON LEFT swing CYLINDER, REMOVE two FITTINGS (21) and two packings (22). INSTALL CAPS or PLUGS. DISCARD PACKINGS.

INSTALLATION

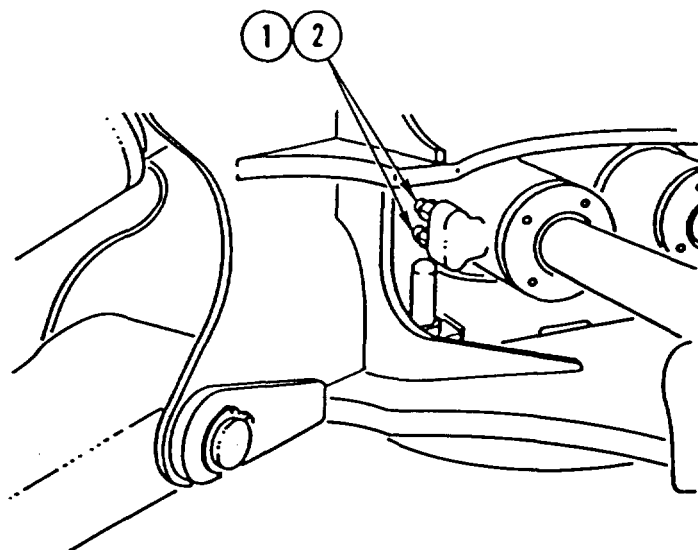

NOTE

Procedure is the same for both swing cylinders except as noted.

1. ON LEFT swing CYLINDER, REMOVE CAPS or PLUGS. INSTALL two new packings (1) and two FITTINGS (2).

BACKHOE SWING CYLINDER REPLACEMENT (CONT)

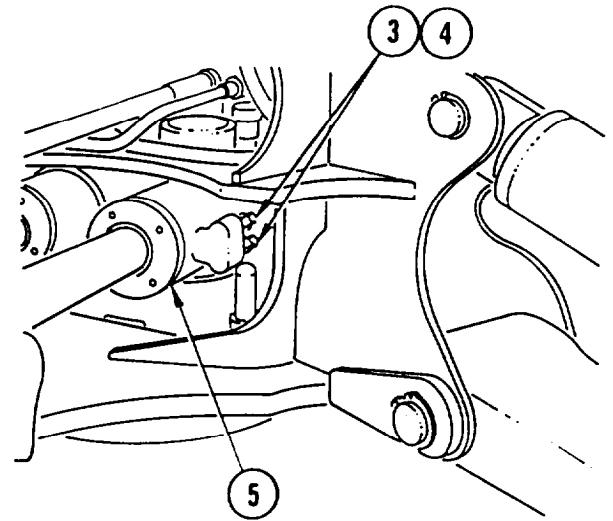
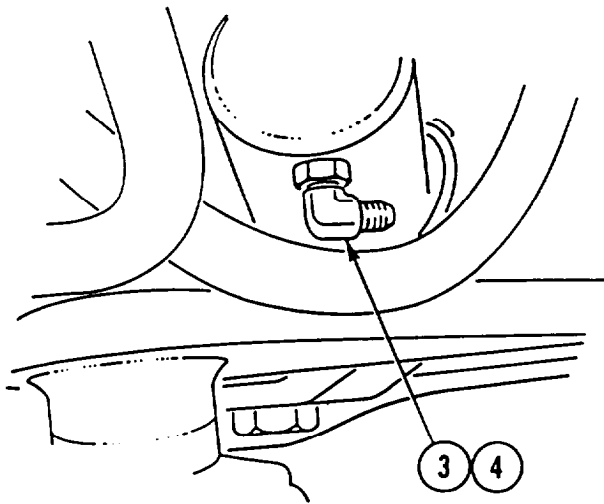

2. ON RIGHT swing CYLINDER, REMOVE CAPS or PLUGS. INSTALL three new packings (3) and three FITTINGS (4).
3. INSTALL swing CYLINDER (5).

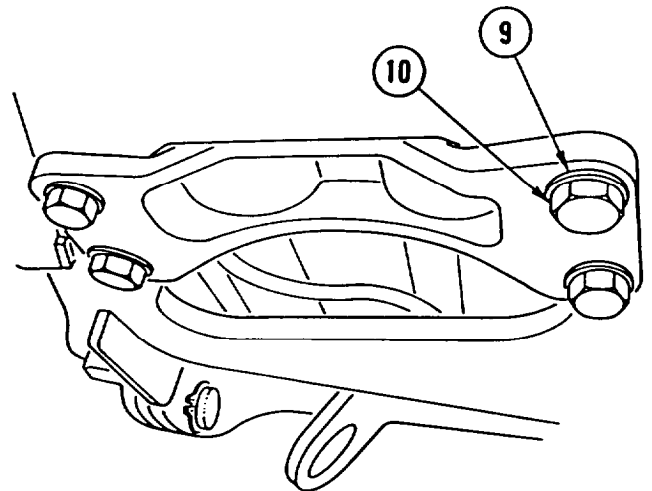
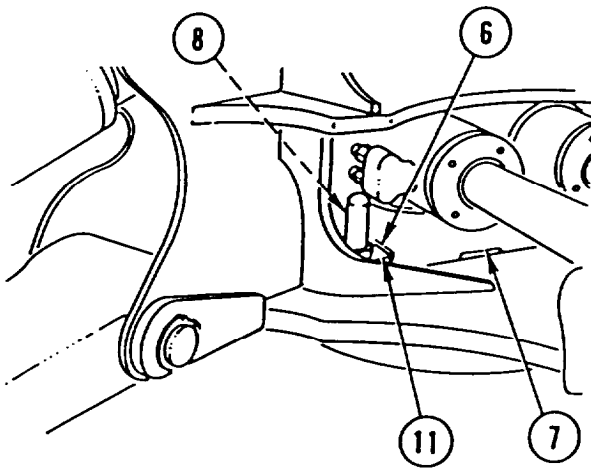

4. INSTALL retainer (6), swing BEAM (7), four nuts (8), four washers (9), four screws (10), and two grips (11).

BACKHOE SWING CYLINDER REPLACEMENT (CONT)

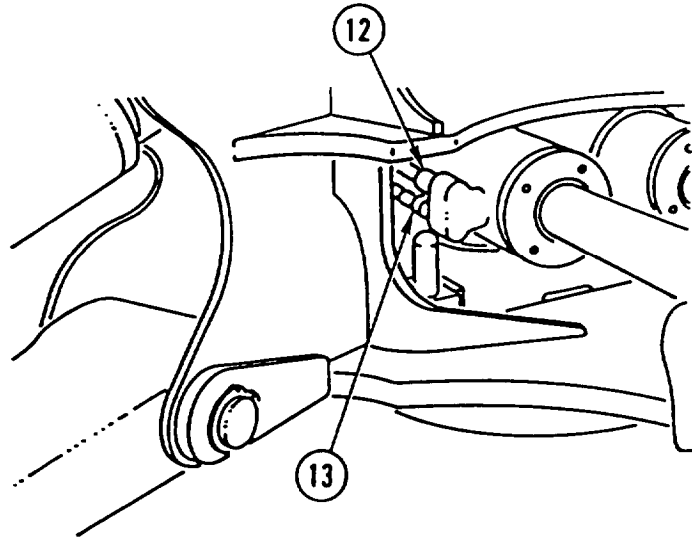

5. ON LEFT swing CYLINDER, REMOVE CAPS or PLUGS. CONNECT two HOSES (12 and 13).

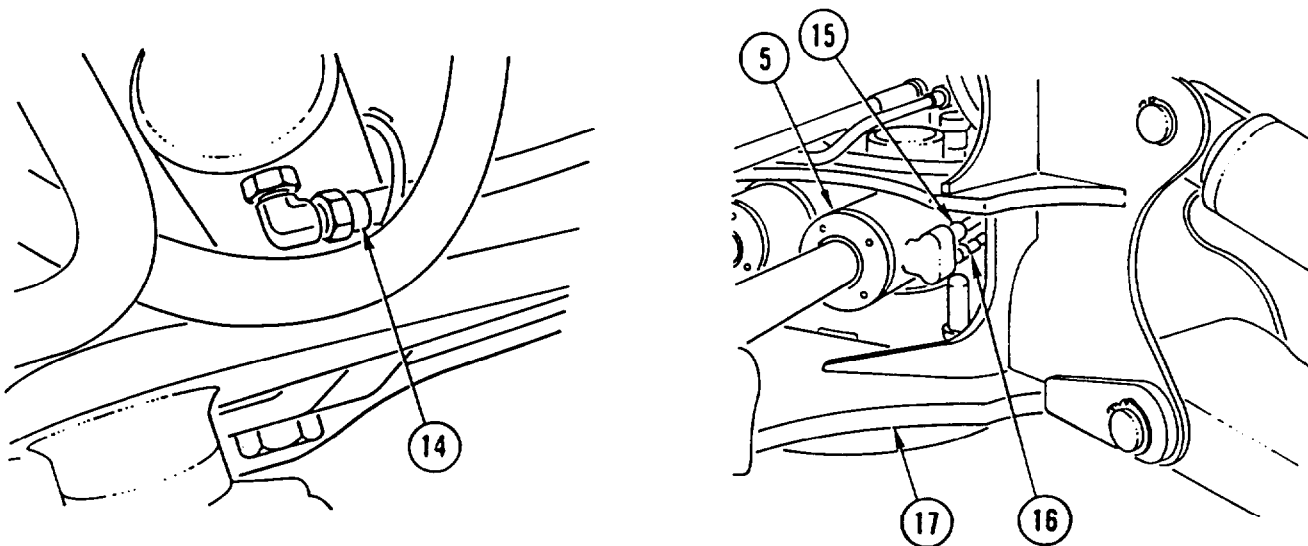

6. ON RIGHT swing CYLINDER, REMOVE CAPS or PLUGS. CONNECT three HOSES (14, 15, and 16).
7. PUSH swing CYLINDER (5) in toward inner swing tower (17).
8. HYDRAULICALLY EXTEND swing CYLINDER (5).

BACKHOE SWING CYLINDER REPLACEMENT (CONT)

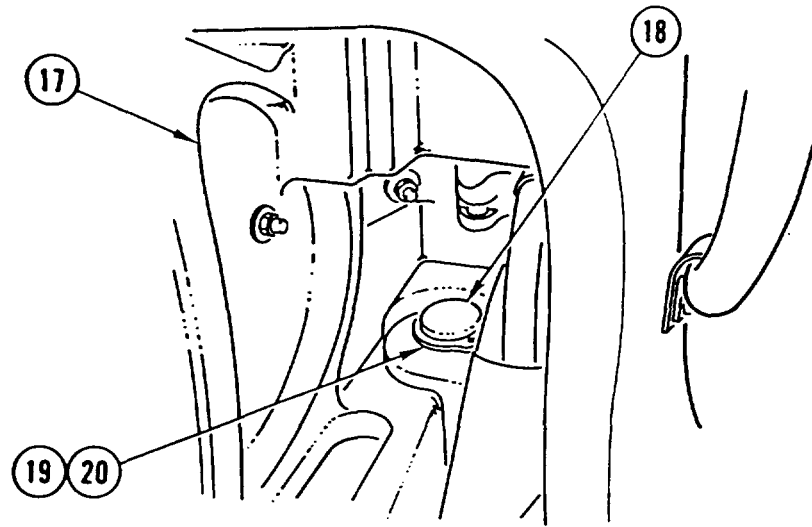

9. INSTALL PIN (18), washer (19), and retaining ring (20) in inner swing tower (17).

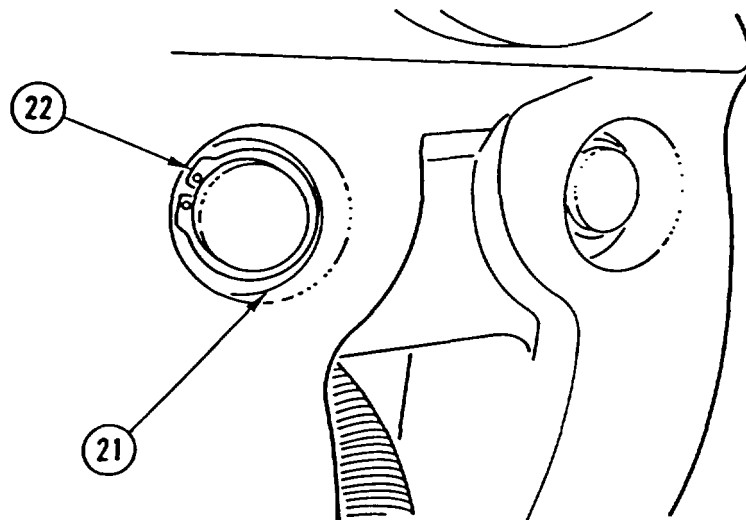

10. INSTALL washer (21) and retaining RING (22).

NOTE

Follow-on Maintenance:
Check rear hydraulic tank (TM 5-2420-224-10).

BACKHOE BUCKET CYLINDER REPLACEMENT

This task covers: a. Removal b. Installation

INITIAL SETUP

Applicable Configuration:

SEE

Tools and Special Equipment:

Shop Equipment, SC 4910-95-CL-A74
Tool Kit, SC 5180-90-CL-N26

Materials/Parts:

Packing (2)

Caps and Plugs Appendix C, Item 7

Rags Appendix C, Item 32

Personnel Required: (2)

References:

TM 5-2420-224-10

Equipment Condition:

Reference	Condition Description
Page 2-22	Backhoe in Three-Point Stance
Page 2-23	Hydraulic Pressure Relieved

General Safety Instructions:

WARNING

- High pressure hydraulics [oil under 2450 psi (16,893 kPa)] operate this equipment. Never disconnect any hydraulic line or fitting without first dropping pressure to zero. A high pressure oil stream can pierce body and cause severe injury to personnel.
- Backhoe bucket cylinder weighs 83 pounds (38 kilograms). To avoid personal injury, use a hoist or suitable lifting device when lifting backhoe bucket cylinder.
- Fuel and oil are slippery and can cause falls. To avoid injury, wipe up spilled fuel or oil with rags.

REMOVAL

CAUTION

Cap or plug all ports and ends of hoses and tubes to prevent contamination of hydraulic oil. Failure to do so may result in damage to equipment.

NOTE

Tag lines prior to disconnecting to aid in connecting.

1. DISCONNECT two HOSES (1 and 2). INSTALL CAPS or PLUGS.

BACKHOE BUCKET CYLINDER REPLACEMENT (CONT)

WARNING

Support backhoe bucket links when removing front pin. Failure to do so could result in injury to personnel.

2. REMOVE 2 retaining rings (3 and 4), 11 washers (5 and 6), 2 pins (7 and 8), and bucket CYLINDER (9).
3. REMOVE clamp (10), TUBE (11), two fittings (12 and 13), and two packings (14 and 15). DISCARD PACKINGS.

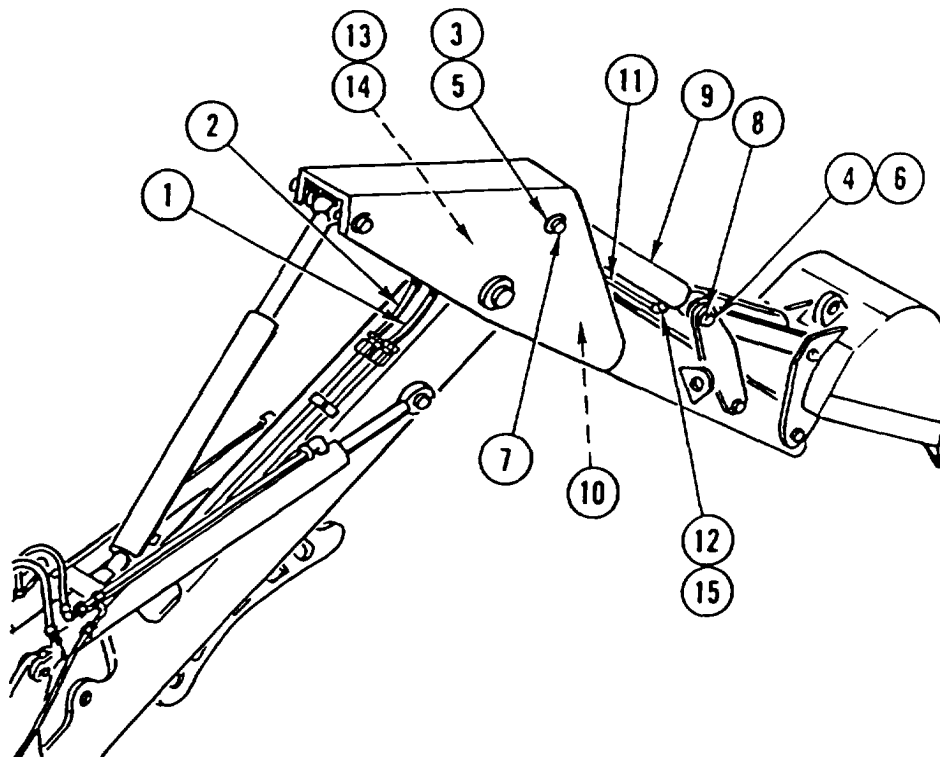
**INSTALLATION**

1. INSTALL two fittings (12 and 13), two new packings (14 and 15), TUBE (11), and clamp (10).
2. INSTALL bucket CYLINDER (9), 2 pins (7 and 8), 11 washers (5 and 6), and 2 retaining rings (3 and 4).
3. REMOVE CAPS or PLUGS. CONNECT two HOSES (1 and 2).

NOTE

Follow-on Maintenance:

Cycle backhoe bucket cylinder (TM 5-2420-224-10).
Check rear hydraulic tank (TM 5-2420-224-10).

BACKHOE DIPPER CYLINDER REPLACEMENT

This task covers: a. Removal b. Installation

INITIAL SETUP

Applicable Configuration:

SEE

Tools and Special Equipment:

Shop Equipment, SC 4910-95-CL-A74
 Tool Kit, SC 5180-90-CL-N26

Materials/Patts:

Washer, Lock (2)

Packing (2)

Caps and Plugs Appendix C, Item 7

Rags Appendix C, Item 32

Personnel Required: (2)

References:

TM 5-2420-224-10

Equipment Condition:

Reference	Condition Description
Page 2-22	Backhoe in Three-Point Stance
Page 2-23	Hydraulic Pressure Relieved

General Safety Instructions:

WARNING

- High pressure hydraulics [oil under 2450 psi (16,893 kPa)] operate this equipment. Never disconnect any hydraulic line or fitting without first dropping pressure to zero. A high pressure oil stream can pierce body and cause severe injury to personnel.
- Backhoe dipper cylinder weighs 107 pounds (49 kilograms). To avoid personal injury, use a hoist or suitable lifting device when lifting backhoe dipper cylinder.
- Fuel and oil are slippery and can cause falls. To avoid injury, wipe up spilled fuel or oil with rags.

REMOVAL

NOTE

Quantity of washers may vary from zero to several.

1. REMOVE two retaining rings (1), washer(s) (2), and PIN (3).
2. USING suitable HOIST, SUPPORT upper part of dipper CYLINDER (4) and FULLY RETRACT piston ROD (5) hydraulically.

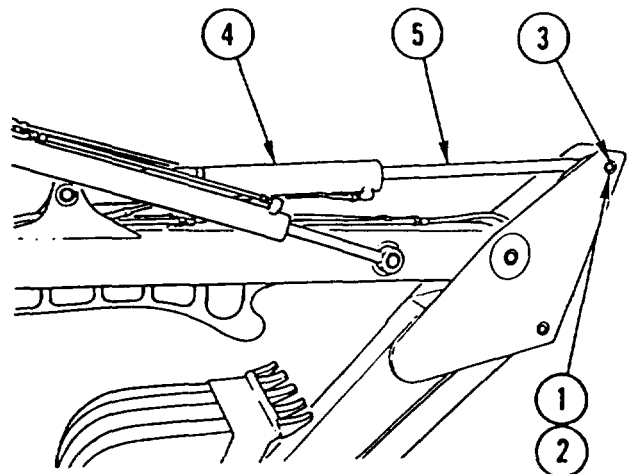

BACKHOE DIPPER CYLINDER REPLACEMENT (CONT)

3. REMOVE two nuts (6), two lock washers (7), and CLAMP (8). DISCARD lock WASHERS.

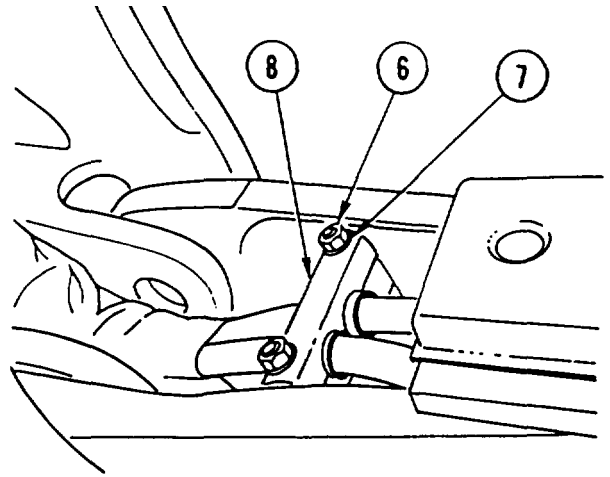

4. REMOVE nut (9), screw (10), and CLAMP (11).
5. REMOVE two retaining rings (12) and PIN (13).

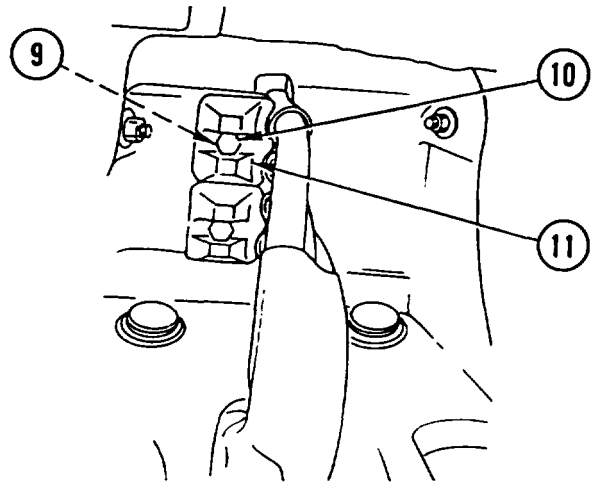

CAUTION

Cap or plug all ports and ends of hoses and tubes to prevent contamination of hydraulic oil. Failure to do so may result in damage to equipment.

NOTE

Tag lines prior to disconnecting to aid in connecting.

6. USING suitable HOIST, LIFT dipper CYLINDER (4) enough to DISCONNECT two HOSES (14 and 15) and REMOVE dipper CYLINDER (4). INSTALL CAPS or PLUGS.
7. REMOVE clamp (16), TUBE (17), two fittings (18 and 19), and two packings (20 and 21). INSTALL CAPS or PLUGS. DISCARD PACKINGS.

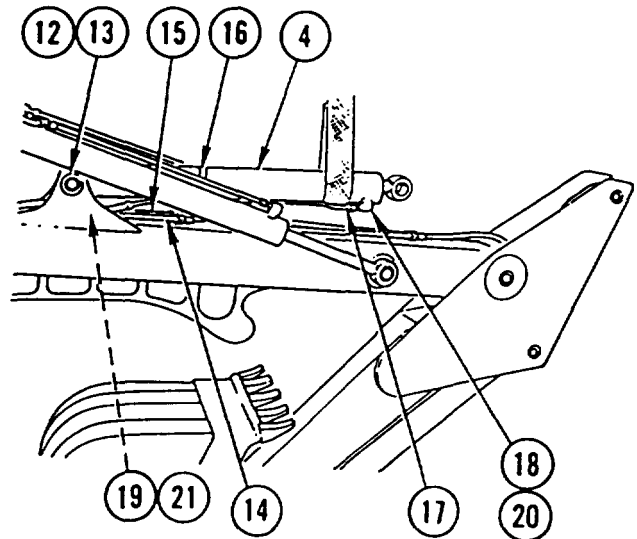

BACKHOE DIPPER CYLINDER REPLACEMENT (CONT)

INSTALLATION

1. REMOVE CAPS or PLUGS. INSTALL two new packings (1 and 2), two fittings (3 and 4), TUBE (5), and clamp (6).
2. USING suitable HOIST, LIFT dipper CYLINDER (7) into place. REMOVE CAPS or PLUGS. CONNECT two HOSES (8 and 9).
3. INSTALL PIN (10) and two retaining rings (11).
4. INSTALL CLAMP (12), screw (13), and nut (14).
5. INSTALL CLAMP (15), two new lock washers (16), and two nuts (17).
6. HYDRAULICALLY EXTEND piston ROD (18) enough to INSTALL PIN (19) and washer(s) (20) to maintain 0.070-in. (1.8-mm) clearance.
7. INSTALL two retaining RINGS (21).

NOTE

Follow-on Maintenance:
Check rear hydraulic tank (TM 5-2420-224-10).

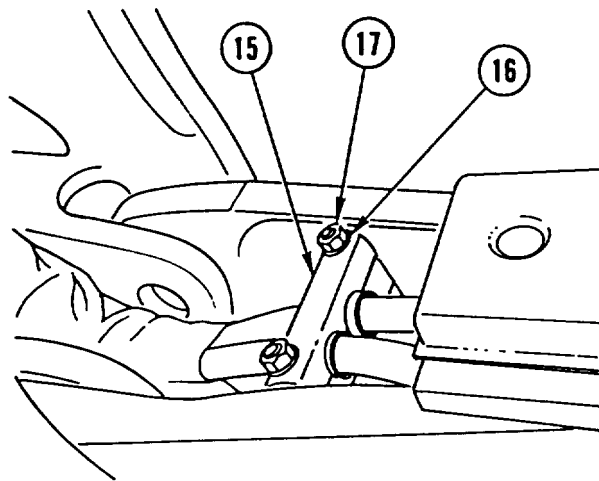
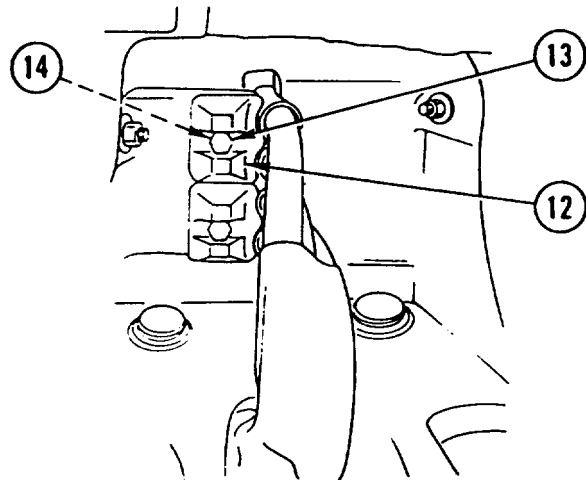
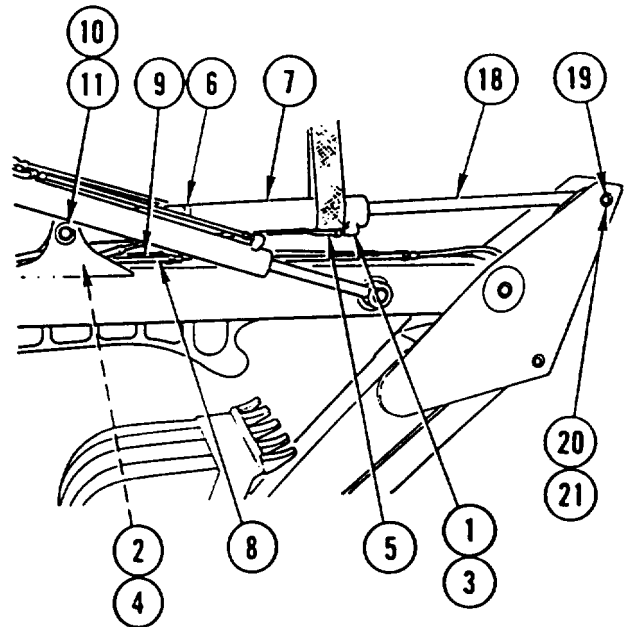

BACKHOE STABILIZER CYLINDER REPLACEMENT

This task covers: a. Removal b. Installation

INITIAL SETUP

Applicable Configuration:

SEE

Tools and Special Equipment:

Shop Equipment, SC 4910-95-CL-A74
 Tool Kit, SC 5180-90-CL-N26

Materials/Parts:

Packing (2)

Caps and Plugs Appendix C, Item 7

Rags Appendix C, Item 32

Personnel Required: (2)

References:

TM 5-2420-224-10

Equipment Condition:

Reference	Condition Description
Page 2-22	Backhoe in Three-Point Stance
Page 2-23	Hydraulic Pressure Relieved

General Safety Instructions:

W A R N I N G

- High pressure hydraulics [oil under 2450 psi (16,893 kPa)] operate this equipment. Never disconnect any hydraulic line or fitting without first dropping pressure to zero. A high pressure oil stream can pierce body and cause severe injury to personnel.
- Backhoe stabilizer cylinder weighs 77 pounds (35 kilograms). To avoid personal injury, use a hoist or suitable lifting device when lifting backhoe stabilizer cylinder.
- Fuel and oil are slippery and can cause falls. To avoid injury, wipe up spilled fuel or oil with rags.

REMOVAL

CAUTION

Cap or plug all ports and ends of hoses and tubes to prevent contamination of hydraulic oil. Failure to do so may result in damage to equipment.

NOTE

- Procedure is the same for both stabilizer cylinders.
- Tag lines prior to disconnecting to aid in connecting.

BACKHOE STABILIZER CYLINDER REPLACEMENT (CONT)

1. DISCONNECT two HOSES (1 and 2). INSTALL CAPS or PLUGS.
2. REMOVE two retaining rings (3) and ROD (4).
3. REMOVE two retaining rings (5), pin (6), and stabilizer CYLINDER (7).
4. REMOVE clamp (8), TUBE (9), two fittings (10 and 11), and two packings (12 and 13) from stabilizer cylinder. INSTALL CAPS or PLUGS. DISCARD PACKINGS.

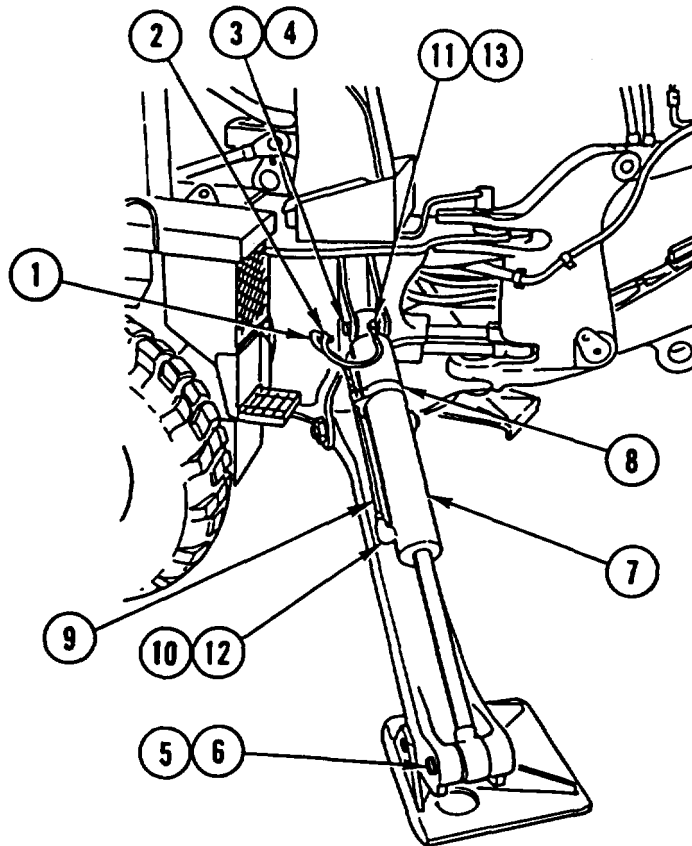

INSTALLATION

NOTE

Procedure is the same for both stabilizer cylinders.

1. REMOVE CAPS or PLUGS. INSTALL two fittings (10 and 11), two new packings (12 and 13), TUBE (9), and clamp (8) on stabilizer cylinder (7).
2. INSTALL stabilizer CYLINDER (7), pin (6), and two retaining rings (5).
3. INSTALL ROD (4) and two retaining rings (3).
4. REMOVE CAPS or PLUGS. CONNECT two HOSES (1 and 2).

NOTE

Follow-on Maintenance:
Check rear hydraulic tank (TM 5-2420-224-10).

BACKHOE/CRANE TILT CYLINDER REPLACEMENT

This task covers: a. Removal b. Installation

INITIAL SETUP

Tools and Special Equipment:

Shop Equipment, SC 4910-95-CL-A74
 Tool Kit, SC 5180-90-CL-N26

General Safety Instructions:

WARNING

- High pressure hydraulics [oil under 2450 psi (16,893 kPa)] operate this equipment. Never disconnect any hydraulic line or fitting without first dropping pressure to zero. A high pressure oil stream can pierce body and cause severe injury to personnel.
- Fuel and oil are slippery and can cause falls. To avoid injury, wipe up spilled fuel or oil with rags.

Materials/Parts:

Packing (2)

Caps and Plugs Appendix C, Item 7

Rags Appendix C, Item 32

References:

TM 5-2420-224-10

Equipment Condition:

Reference	Condition Description
Page 2-22 or 2-23	Backhoe (SEE) or Crane (HMMH) in Three-Point Stance
Page 2-23	Hydraulic Pressure Relieved

REMOVAL

CAUTION

Cap or plug all ports and ends of hoses and tubes to prevent contamination of hydraulic oil. Failure to do so may result in damage to equipment.

NOTE

- Procedure is the same for both vehicles.
- Tag lines prior to disconnecting to aid in connecting.

BACKHOE/CRANE TILT CYLINDER REPLACEMENT (CONT)

1. DISCONNECT two hydraulic HOSES (1 and 2). INSTALL CAPS or PLUGS.
2. REMOVE four snap rings (3 and 4), two pins (5 and 6), and tilt CYLINDER (7).
3. REMOVE two FITTINGS (8 and 9) and two packings (10 and 11). DISCARD PACKINGS.

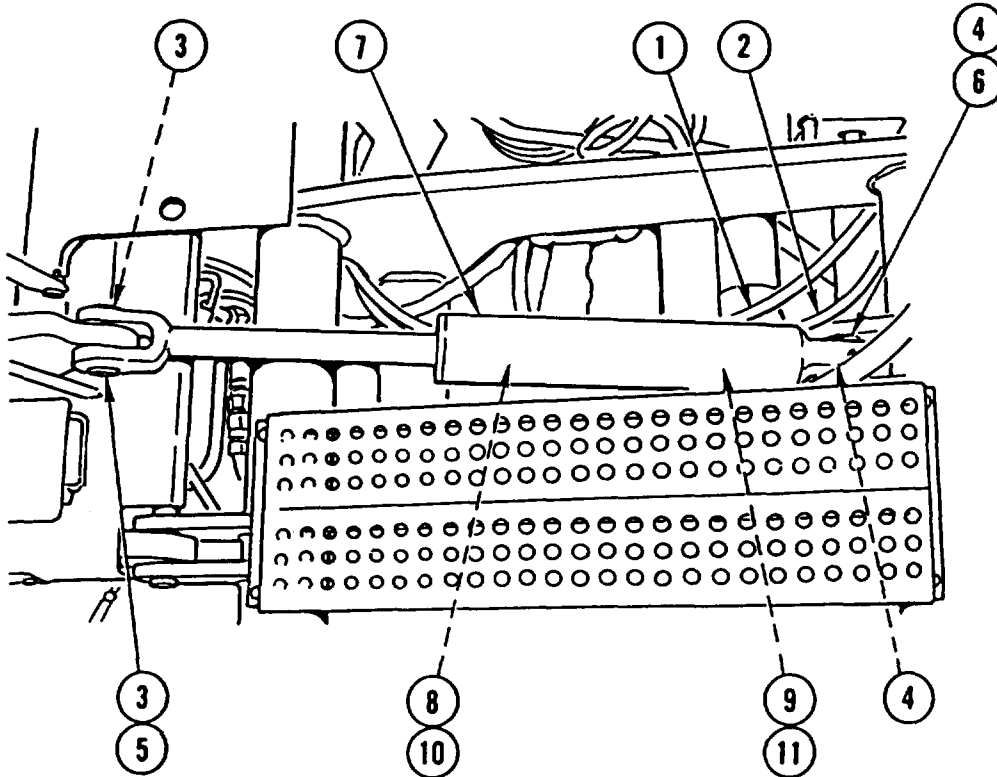

INSTALLATION

NOTE

Procedure is the same for both vehicles.

1. INSTALL two new packings (10 and 11) and two FITTINGS (8 and 9).
2. INSTALL tilt CYLINDER (7), two pins (5 and 6), and four snap rings (3 and 4).
3. REMOVE CAPS or PLUGS. CONNECT two hydraulic HOSES (1 and 2).

NOTE

Follow-on Maintenance:
Check front hydraulic tank (TM 5-2420-224-10).

BACKHOE/CRANE LATCH CYLINDER MOUNTING REPLACEMENT

This task covers: a. Removal b. Installation

INITIAL SETUP

Tools and Special Equipment:

Shop Equipment, SC 4910-95-CL-A74
 Tool Kit, SC 5180-90-CL-N26

References:

TM 5-2420-224-10

Equipment Condition:

Reference

TM 5-2420-224-10

Page 4-684

Condition Description

Backhoe (SEE) or Crane (HMMH) in Transport Position

Backhoe Latch Cylinder (SEE) or Crane Latch Cylinder (HMMH) Removed

REMOVAL

NOTE

- Procedure is the same for both vehicles.
- Procedure is the same for both latch cylinder mountings.

REMOVE two snap rings (1), pin (2), and latch cylinder MOUNTING (3).

INSTALLATION

NOTE

- Procedure is the same for both vehicles.
- Procedure is the same for both latch cylinder mountings.

INSTALL latch cylinder MOUNTING (3), pin (2), and two snap rings (1).

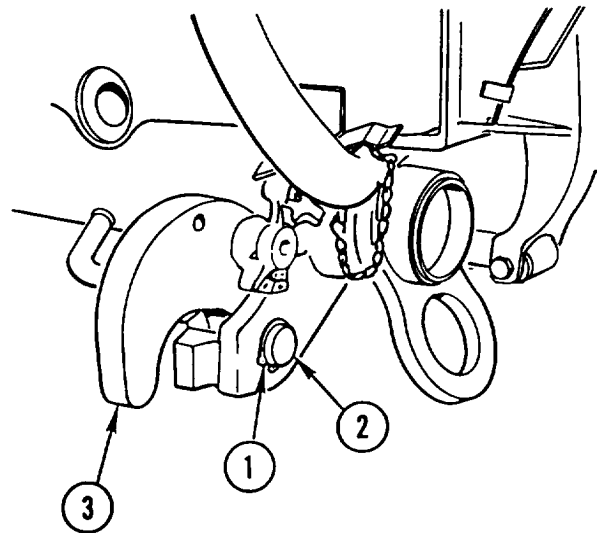

NOTE

Follow-on Maintenance:

Install backhoe latch cylinder (SEE) or crane latch cylinder (HMMH) (page 4-684).

BACKHOE TRAVEL LOCK REPLACEMENT AND REPAIR

This task covers: a. Removal b. Disassembly c. Inspection d. Assembly e. Installation

INITIAL SETUP

Applicable Configuration:

SEE (Serial No. 451701 and Below)

Tools and Special Equipment:

Tool Kit, SC 5180-90-CL-N26

Materials/Parts:

Pin, Cotter (2)

Nut, Lock (2)

Equipment Condition:

Reference

Page 2-22

Condition Description

Backhoe in Three-Point Stance

REMOVAL

NOTE

If Serial No. is 451701 or below and travel lock has been previously replaced, perform Backhoe Travel Lock Replacement and Repair (page 4-681).

1. REMOVE cotter pin (1) and PIN (2). DISCARD cotter PIN.
2. REMOVE CLEWS (3) and nut (4).
3. PULL CONTROL assembly (5) through latch assembly (6).
4. REMOVE knob (7), nut (8), nut (9), and CONTROL assembly (5) through bracket (10).
5. REMOVE two bolts (11), two nuts (12), and BRACKET (10).

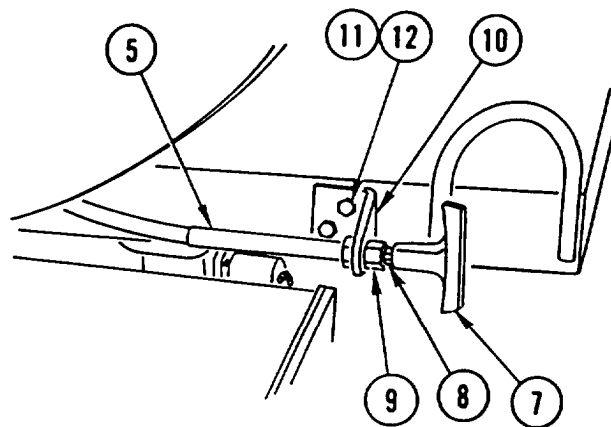
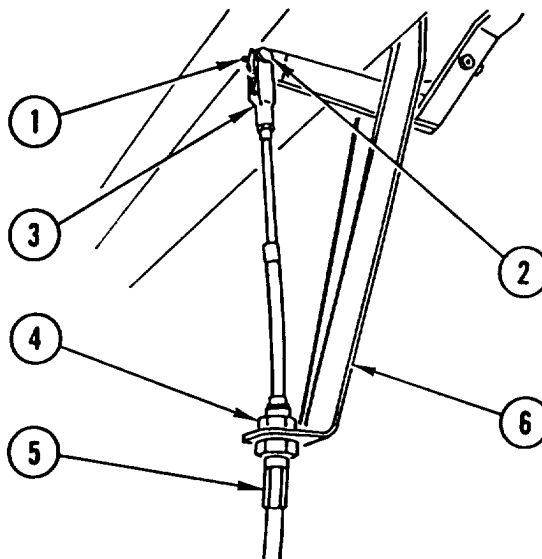

BACKHOE TRAVEL LOCK REPLACEMENT AND REPAIR (CONT)

6. REMOVE two lock nuts (13), two bolts (14), and LATCH assembly (6). DISCARD lock NUTS.
7. REMOVE cotter pin (15), pin (16), and CLEVIS (17). DISCARD cotter PIN.
8. REMOVE four screws (18), four nuts (19), and PLATE (20).

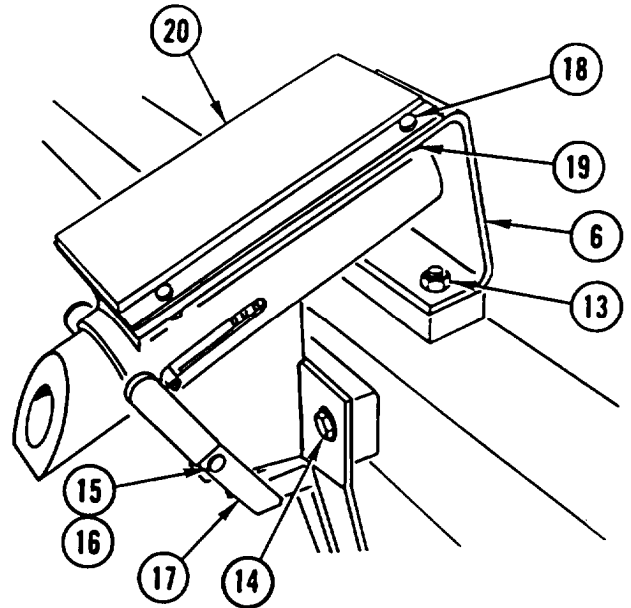
DISASSEMBLY

1. REMOVE PIN (1), bolt (2), and spring (3) from bracket (4).
2. REMOVE lubrication FITTING (5) and BUSHING (6) from bolt (2).

INSPECTION

1. Inspect bracket for cracks or broken welds.
2. Inspect parts for sticking, wear, and damage.

ASSEMBLY

1. INSTALL BUSHING (6) and lubrication FITTING (5) in twit (2).
2. INSTALL spring (3), bolt (2), and PIN (1) in bracket (4).

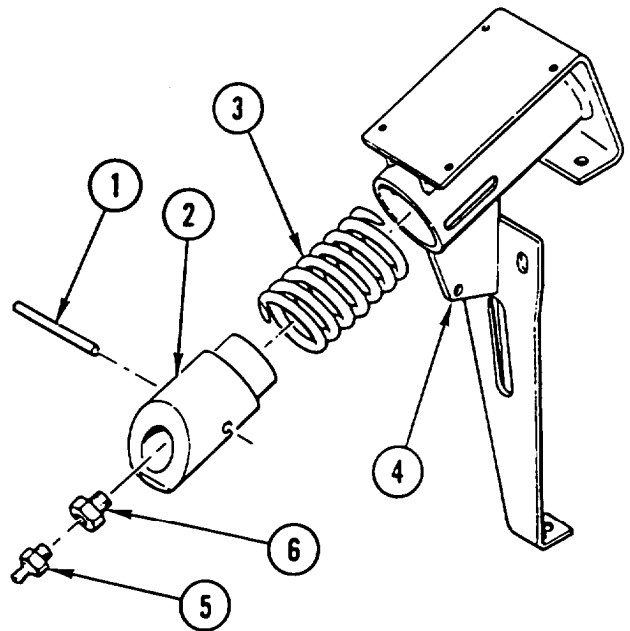

BACKHOE TRAVEL LOCK REPLACEMENT AND REPAIR (CONT)

INSTALLATION

1. INSTALL four screws (1), four nuts (2), and PLATE (3) on latch assembly (4).
2. INSTALL CLEW (5), pin (6), and new cotter pin (7).
3. INSTALL LATCH assembly (4), two bolts (8), and two new lock nuts (9).
4. INSTALL two bolts (10), two nuts (11), and BRACKET (12).
5. INSTALL CONTROL assembly (13) and nut (14) in bracket (12).
6. INSTALL nut (15) and KNOB (16) on control assembly (13).
7. INSTALL CONTROL assembly (13) and nut (17) in latch assembly (4).
8. INSTALL CLEVIS (18).
9. INSTALL PIN (19) and new cotter pin (20).

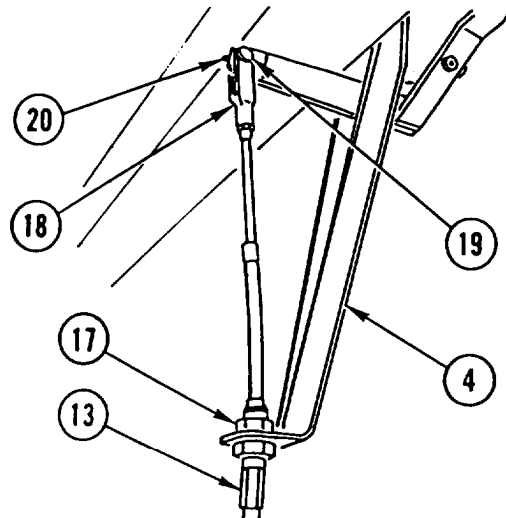
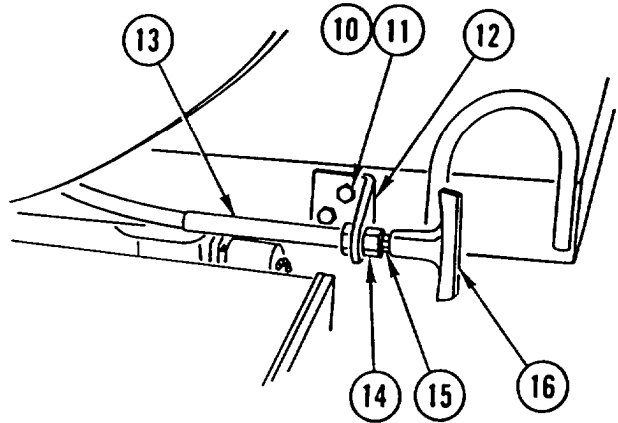
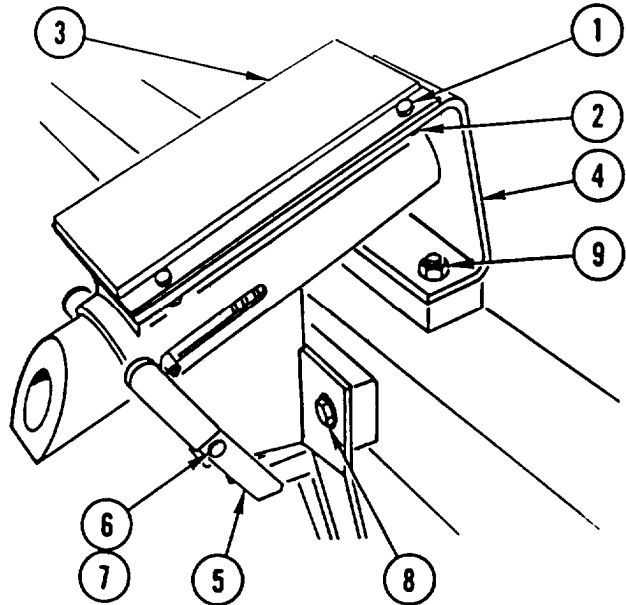

BACKHOE TRAVEL LOCK REPLACEMENT AND REPAIR

This task covers: a. Removal b. Disassembly c. Inspection d. Assembly e. Installation

INITIAL SETUP

Applicable Configuration:

SEE (serial No. 451702 and Above)

Tools and Special Equipment:

Tool Kit, SC 5180-90-CL-N26

Materials/Parts:

Pin, Cotter (2)

Nut, Lock (2)

Equipment Condition:

Reference

Page 2-22

Condition Description

Backhoe in Three-Point Stance

REMOVAL

1. REMOVE cotter pin (1) and PIN (2). DISCARD cotter PIN.
2. REMOVE CLEVIS (3) and nut (4).
3. PULL CONTROL assembly (5) through latch assembly (6).
4. REMOVE knob (7), nut (8), nut (9), and CONTROL assembly (5) through bracket (10).
5. REMOVE two bolts (11), two nuts (12), and BRACKET (10).

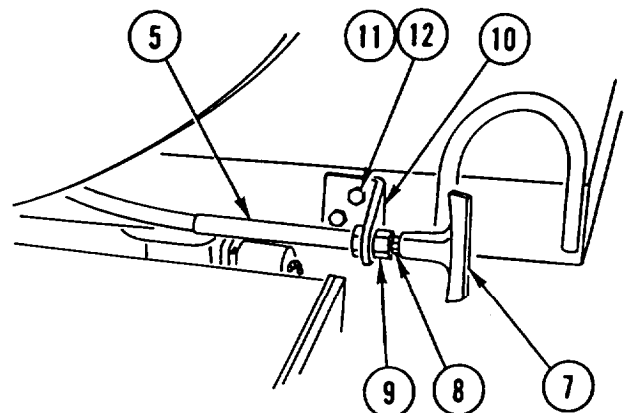
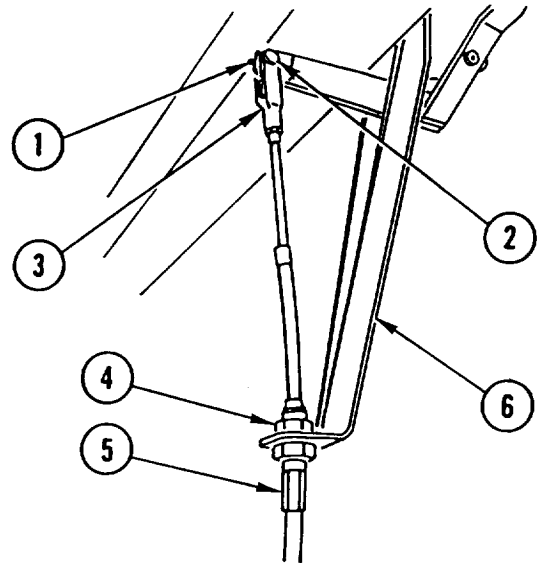

BACKHOE TRAVEL LOCK REPLACEMENT AND REPAIR (CONT)

6. REMOVE two lock nuts (13), four bolts (14), and LATCH assembly (6). DISCARD lock NUTS.
7. REMOVE cotter pin (15), pin (16), and CLEVIS (17). DISCARD alter PIN.
8. REMOVE four screws (18), four nuts (19), and PLATE (20).

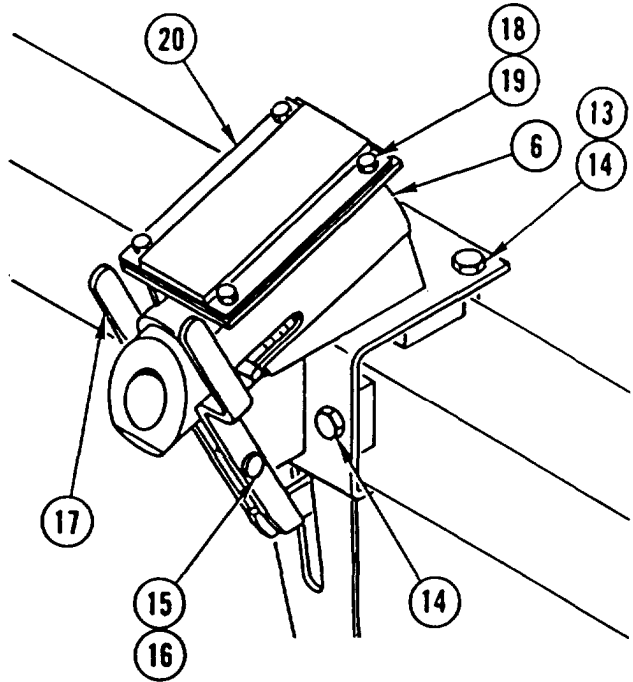

DISASSEMBLY

1. REMOVE PIN (1), bolt (2), and spring (3) from bracket (4).
2. REMOVE lubrication FITTING (5) and BUSHING (6) from bolt (2).

INSPECTION

1. Inspect bracket for cracks or broken welds.
2. Inspect parts for sticking, wear, and damage.

ASSEMBLY

1. INSTALL BUSHING (6) and lubrication FITTING (5) in bolt (2).
2. INSTALL spring (3), bolt (2), and PIN (1) in bracket (4).

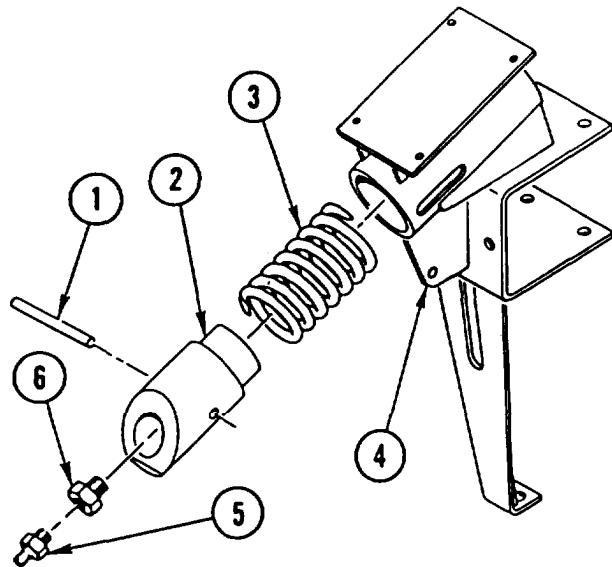

BACKHOE TRAVEL LOCK REPLACEMENT AND REPAIR (CONT)

INSTALLATION

1. INSTALL four screws (1), four nuts (2), and PLATE (3) on latch assembly (4).
2. INSTALL CLEWS (5), pin (6), and new cotter pin (7).
3. INSTALL LATCH assembly (4), four bolts (8), and two new lock nuts (9).

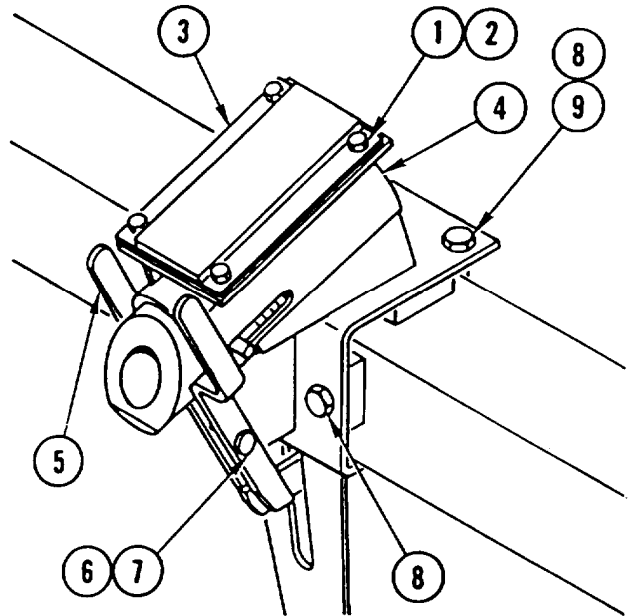

4. INSTALL two bolts (10), two nuts (11), and BRACKET (12).
5. INSTALL CONTROL assembly (13) and nut (14) in bracket (12).
6. INSTALL nut (15) and KNOB (16) on control assembly (13).

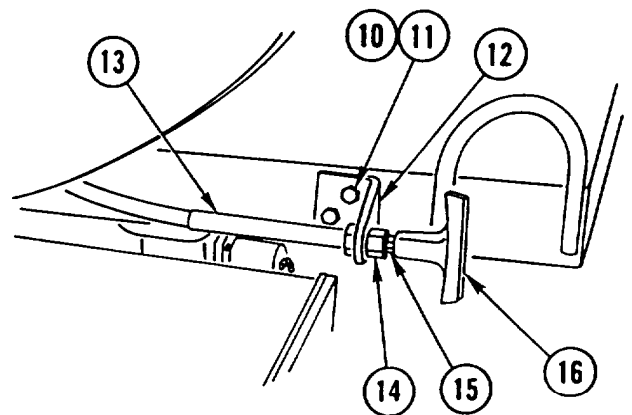

7. INSTALL CONTROL assembly (13) and nut (17) in latch assembly (4).
8. INSTALL CLEVIS (18).
9. INSTALL PIN (19) and new cotter pin (20).

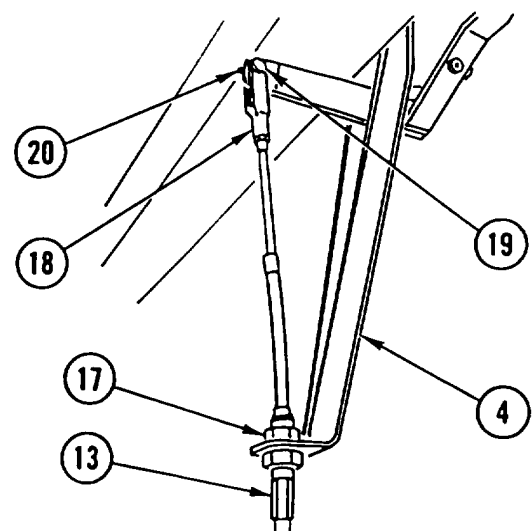

BACKHOE/CRANE LATCH CYLINDER REPLACEMENT

This task covers: a. Removal b. Installation

INITIAL SETUP

Tools and Special Equipment:

Shop Equipment, SC 4910-95-CL-A740
Tool Kit, SC 5180-90-CL-N26

Materials/Parts:

Packing (2)

Caps and Plugs Appendix C, Item 7

Rags Appendix C, Item 32

References:

TM 5-2420-224-10

Equipment Condition:

Reference	Condition Description
TM 5-2420-224-10	Backhoe (SEE) or Crane (HMMH) in Stowed Position
Page 2-23	Hydraulic Pressure Relieved

General Safety Instructions:

WARNING

- High pressure hydraulics [oil under 2450 psi (16,893 kPa)] operate this equipment. Never disconnect any hydraulic line or fitting without first dropping pressure to zero. A high pressure oil stream can pierce body and cause severe injury to personnel.
- Fuel and oil are slippery and can cause falls. To avoid injury, wipe up spilled fuel or oil with rags.

REMOVAL

CAUTION

Cap or plug all ports and ends of hoses and tubes to prevent contamination of hydraulic oil. Failure to do so may result in damage to equipment.

NOTE

- Procedure is the same for both vehicles.
 - Procedure is the same for both latch cylinders.
 - Tag lines prior to disconnecting to aid in connecting.
1. DISCONNECT two hydraulic HOSES (1 and 2). INSTALL CAPS or PLUGS.
 2. REMOVE four snap rings (3 and 4), two pins (5 and 6), and latch CYLINDER (7).
 3. REMOVE two FITTINGS (8 and 9) and two packings (10 and 11) from latch cylinder (7). DISCARD PACKINGS.

BACKHOE/CRANE LATCH CYLINDER REPLACEMENT (CONT)

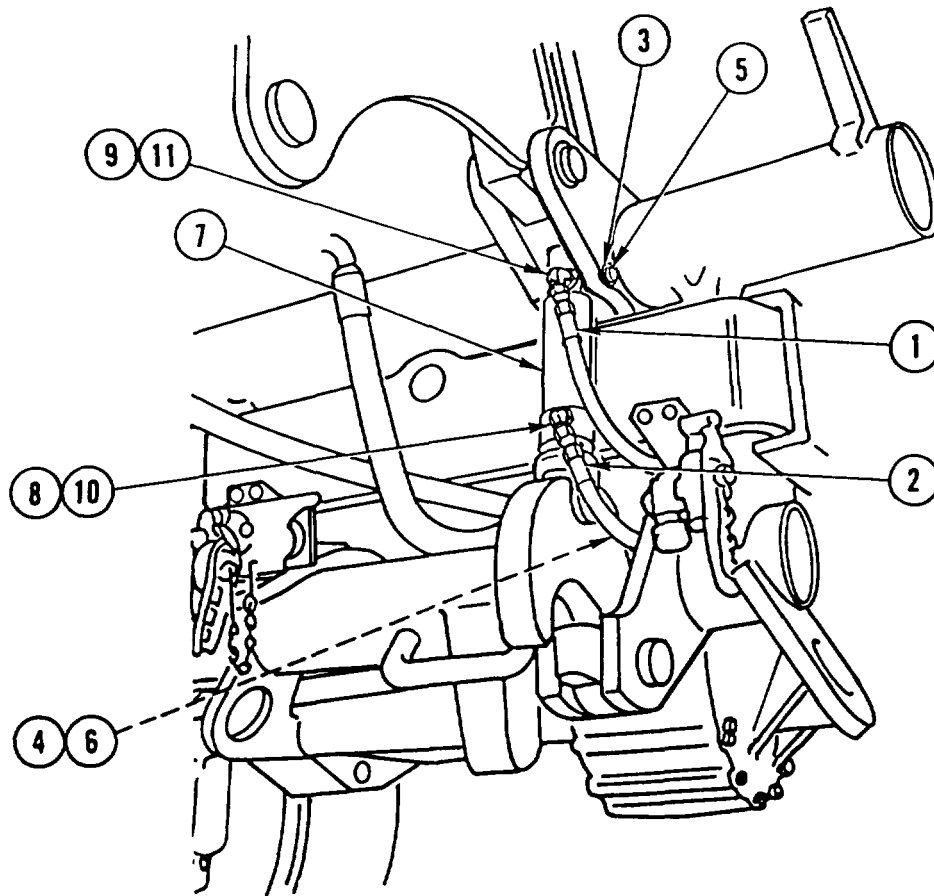
INSTALLATION
NOTE

- Procedure is the same for both vehicles.
 - Procedure is the same for both latch cylinders.
1. INSTALL two new packings (10 and 11) and two FITTINGS (8 and 9) on latch cylinder (7).
 2. INSTALL latch CYLINDER (7), two pins (5 and 6), and four snap rings (3 and 4).
 3. REMOVE CAPS or PLUGS. CONNECT two hydraulic HOSES (1 and 2).

NOTE

Follow-on Maintenance:
Check front hydraulic tank (TM 5-2420-224-10).

FORKLIFT TILT CYLINDER REPLACEMENT

This task covers: a. Removal b. Installation

INITIAL SETUP

Applicable Configuration:

HMMH

Tools and Special Equipment:

Shop Equipment, SC 4910-95-CL-A74
Tool Kit, SC 5180-90-CL-N26

Materials/Parts:

Washer, Lock

Caps and Plugs Appendix C, Item 7

Rags Appendix C, Item 32

References:

TM 5-2420-224-10

Equipment Condition:

Reference	Condition Description
TM 5-2420-224-10	Forklift Lowered to Ground
Page 2-23	Hydraulic Pressure Relieved

General Safety Instructions:

WARNING

- High pressure hydraulics [oil under 2450 psi (16,893 kPa)] operate this equipment. Never disconnect any hydraulic line or fitting without first dropping pressure to zero. A high pressure oil stream can pierce body and cause severe injury to personnel.
- Fuel and oil are slippery and can cause falls. To avoid injury, wipe up spilled fuel or oil with rags.

REMOVAL

CAUTION

Cap or plug all ports and ends of hoses and tubes to prevent contamination of hydraulic oil. Failure to do so may result in damage to equipment.

NOTE

- Procedure is the same for both tilt cylinders.
- Tag lines prior to disconnecting to aid in connecting.

1. DISCONNECT two HOSES (1 and 2). INSTALL CAPS or PLUGS.

FORKLIFT TILT CYLINDER REPLACEMENT (CONT)

2. REMOVE capscrew (3), lock washer (4), eye BOLT (5), and pin (6). DISCARD lock WASHER.
3. REMOVE two screws (7 and 8), retainer (9), and forklift tilt CYLINDER (10).
4. REMOVE two FITTINGS (11 and 12).

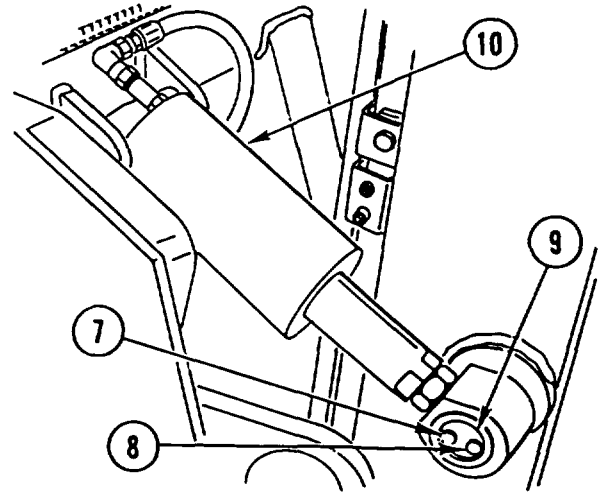
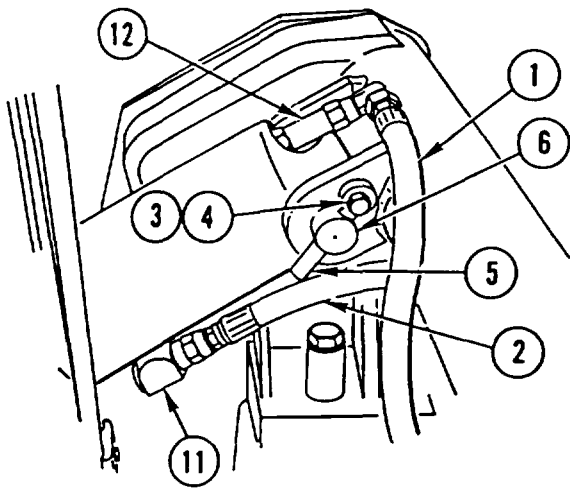

INSTALLATION

NOTE

Procedure is the same for both tilt cylinders.

1. INSTALL two FITTINGS (11 and 12).
2. INSTALL forklift tilt CYLINDER (10, retainer (9), and two screws (8 and 7).
3. INSTALL eye BOLT (5), pin (6), capscrew (3), and new lock washer (4).
4. REMOVE CAPS or PLUGS. CONNECT two HOSES (1 and 2).

NOTE

Follow-on Maintenance:

Check front hydraulic tank (TM 5-2420-224-10).

FORKLIFT ROTATOR CYLINDER REPLACEMENT

This task covers: a. Removal b. Installation

INITIAL SETUP

Applicable Configuration:

HMMH

Tools and Special Equipment:

Shop Equipment, SC 4910-95-CL-A74
Tool Kit, SC 5180-90-CL-N26

Materials/Parts:

Caps and Plugs Appendix C, item 7
Rags Appendix C, Item 32

References:

TM 5-2420-224-10

Equipment Condition:

Reference	Condition Description
TM 5-2420-224-10	Forklift Lowered to Ground
Page 2-23	Hydraulic Pressure Relieved

General Safety Instructions:

WARNING

- High pressure hydraulics [oil under 2450 psi (16,893 kPa)] operate this equipment. Never disconnect any hydraulic line or fitting without first dropping pressure to zero. A high pressure oil stream can pierce body and cause severe injury to personnel.
- Fuel and oil are slippery and can cause falls. To avoid injury, wipe up spilled fuel or oil with rags.

REMOVAL

CAUTION

Cap or plug all ports and ends of hoses and tubes to prevent contamination of hydraulic oil. Failure to do so may result in damage to equipment.

NOTE

Tag lines prior to disconnecting to aid in connecting.

1. DISCONNECT two HOSES (1 and 2). INSTALL CAPS or PLUGS.
2. REMOVE two lock pins (3 and 4), two pins (5 and 6), and forklift rotator CYLINDER (7).
3. REMOVE two FITTINGS (8 and 9).

FORKLIFT ROTATOR CYLINDER REPLACEMENT (CONT)

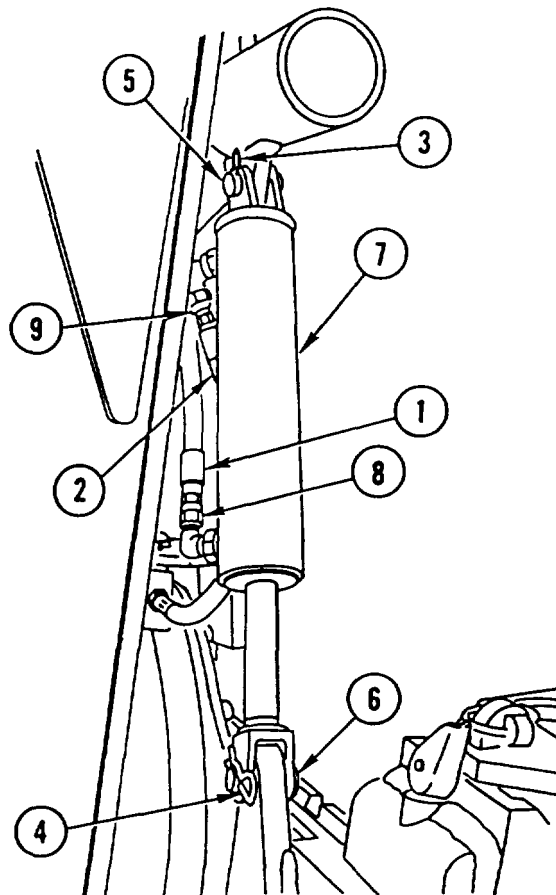
**INSTALLATION**

1. INSTALL two FITTINGS (8 and 9).
2. INSTALL forklift rotator CYLINDER (7), two pins (5 and 6), and two lock pins (3 and 4).
3. REMOVE CAPS or PLUGS. CONNECT two HOSES (1 and 2).

NOTE

Follow-on Maintenance:
Check front hydraulic tank (TM 5-2420-224-10).

CRANE EXTERNAL END EXTENSION CYLINDER REPLACEMENT

This task covers: a. Removal b. Installation

INITIAL SETUP

Applicable Configuration:

HMMH

Tools and Special Equipment:

Shop Equipment, SC 4910-95-CL-A74
Too Kit, SC 5180-90-CL-N26

Materials/Parts:

Caps and Plugs Appendix C, Item 7
Rags Appendix C, Item 32

Personnel Required: (2)

References:

TM 5-2420-224-10

Equipment Condition:

Reference	Condition Description
Page 2-23	Crane in Three-Point Stance
Page 2-23	Hydraulic Pressure Relieved

General Safety Instructions:

WARNING

- High pressure hydraulics [oil under 2450 psi (16,893 kPa)] operate this equipment. Never disconnect any hydraulic line or fitting without first dropping pressure to zero. A high pressure oil stream can pierce body and cause severe injury to personnel.
- Crane external end extension cylinder weighs 169 pounds (77 kilograms). To avoid personal injury, use a hoist or suitable lifting device when lifting crane external end extension cylinder.
- Fuel and oil are slippery and can cause falls. To avoid injury, wipe up spilled fuel or oil with rags.

REMOVAL

CAUTION

Cap or plug all ports and ends of hoses and tubes to prevent contamination of hydraulic oil. Failure to do so may result in damage to equipment.

NOTE

Tag lines prior to disconnecting to aid in connecting.

1. DISCONNECT two HOSES (1 and 2). INSTALL CAPS or PLUGS.
2. REMOVE eight capscrews (3), four retainers (4), and crane external end extension CYLINDER (5).
3. REMOVE two FITTINGS (6 and 7).

CRANE EXTERNAL END EXTENSION CYLINDER REPLACEMENT (CONT)

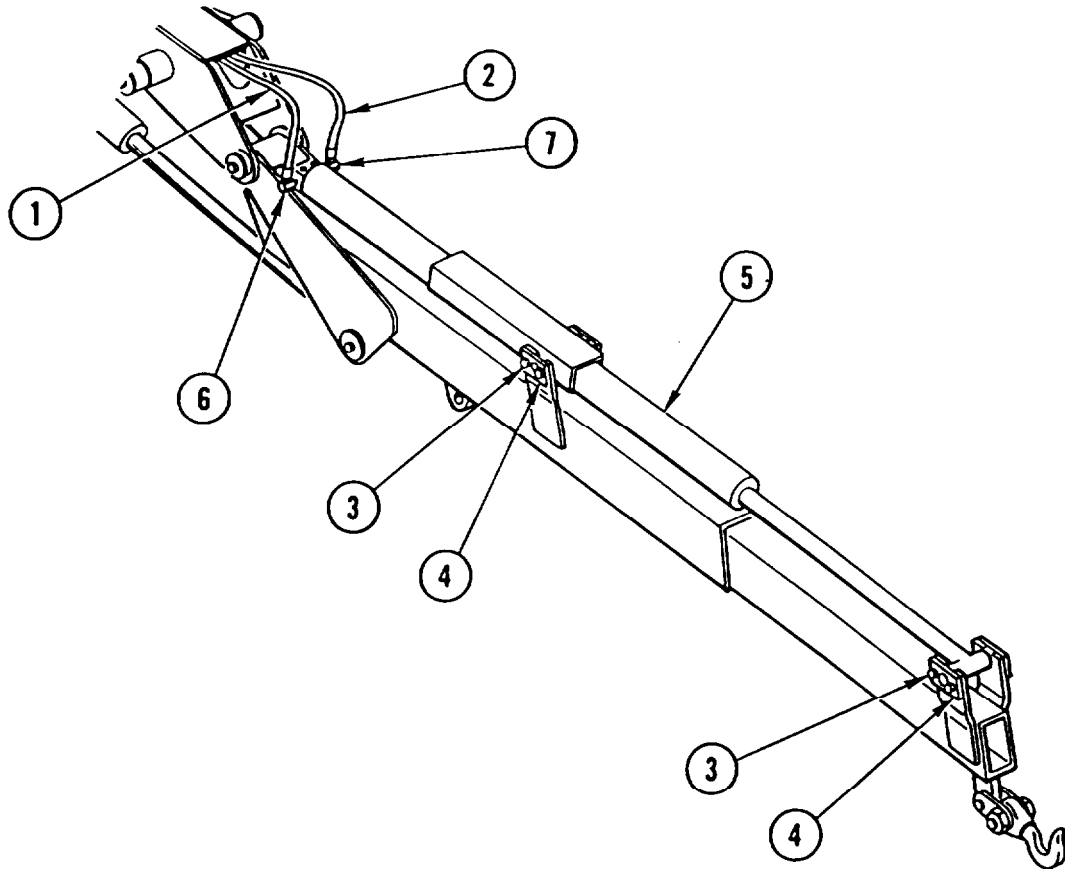
INSTALLATION

1. INSTALL two FITTINGS (6 and 7).
2. INSTALL crane external end extension CYLINDER (5), four retainers (4), and eight capscrews (3).
3. REMOVE CAPS or PLUGS. CONNECT two HOSES (1 and 2).

NOTE

Follow-on Maintenance:
Check rear hydraulic tank (TM 5-2420-224-10).

CRANE INNER BOOM LIFT CYLINDER REPLACEMENT

This task covers: a. Removal b. Installation

INITIAL SETUP

Applicable Configuration:

HMMH

Tools and Special Equipment:

Shop Equipment, SC 4910-95-CL-A74
Tool Kit, SC 5180-90-CL-N26

Materials/Parts:

Caps and Plugs Appendix C, item 7
Rags Appendix C, Item 32

Personnel Required: (2)

References:

TM 5-2420-224-10

Equipment Condition:

Reference	Condition Description
Page 2-23	Crane in Three-Point Stance
Page 2-23	Hydraulic Pressure Relieved

General Safety instructions:

WARNING

- High pressure hydraulics [oil under 2450 psi (16,893 kPa)] operate this equipment. Never disconnect any hydraulic line or fitting without first dropping pressure to zero. A high pressure oil stream can pierce body and cause severe injury to personnel.
- Crane inner boom lift cylinder weighs 219 pounds (100 kilograms). To avoid personal injury, use a hoist or suitable lifting device when lifting crane inner boom lift cylinder.
- Fuel and oil are slippery and can cause falls. To avoid injury, wipe up spilled fuel or oil with rags.

CRANE INNER BOOM LIFT CYLINDER REPLACEMENT (CONT)

REMOVAL**CAUTION**

Cap or plug all ports and ends of hoses and tubes to prevent contamination of hydraulic oil. Failure to do so may result in damage to equipment.

NOTE

- Procedure is the same for both inner boom lift cylinders.
- Tag lines prior to disconnecting to aid in connecting.

1. DISCONNECT two HOSES (1 and 2). INSTALL CAPS or PLUGS.
2. REMOVE two capscrews (3 and 4) and two PLATES (5 and 6).
3. REMOVE capscrew (7), plate (8), and crane inner boom lift CYLINDER (9).
4. REMOVE two FITTINGS (10 and 11).

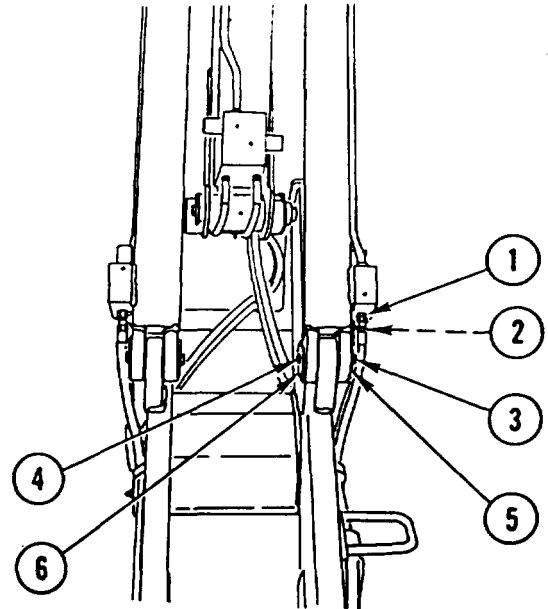
**INSTALLATION****NOTE**

Procedure is the same for both inner boom lift cylinders.

1. INSTALL two FITTINGS (10 and 11).
2. USING suitable HOIST, INSTALL crane inner boom lift CYLINDER (9), capscrew (7), and plate (8).
3. INSTALL two capscrews (3 and 4) and two PLATES (5 and 6).
4. REMOVE CAPS or PLUGS. CONNECT two HOSES (1 and 2).

NOTE

Follow-on Maintenance:

Check rear hydraulic tank (TM 5-2420-224-10).

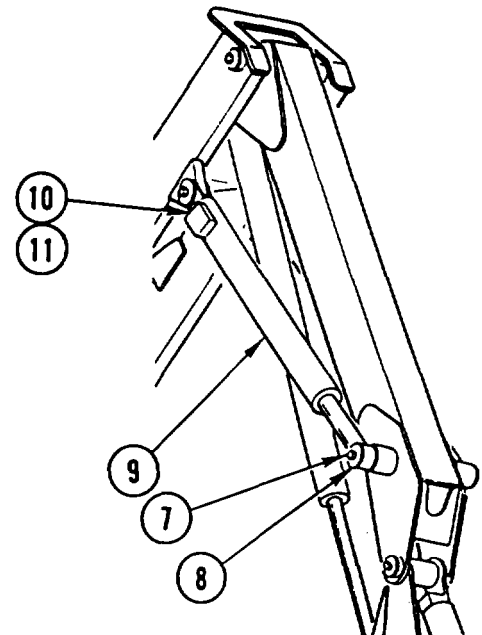

CRANE MAST LOCKING CYLINDER REPLACEMENT

This task covers: a. Removal b. Installation

INITIAL SETUP

Applicable Configuration:

HMMH

Tools and Special Equipment:

Shop Equipment, SC 4910-95-CL-A74
Tool Kit, SC 5180-90-CL-N26

Materials/Parts:

Nut, Lock (2)

Packing

Caps and Plugs Appendix C, Item 7

Rags Appendix C, Item 32

Personnel Required: (2)

References:

TM 5-2420-224-10

Equipment Condition:

Reference	Condition Description
Page 2-23	Crane in Three-Point Stance
Page 2-23	Hydraulic Pressure Relieved

General Safety Instructions:

WARNING

- High pressure hydraulics [oil under 2450 psi (16,893 kPa)] operate this equipment. Never disconnect any hydraulic line or fitting without first dropping pressure to zero. A high pressure oil stream can pierce body and cause severe injury to personnel.
- Crane mast locking cylinder weighs 117 pounds (53 kilograms). To avoid personal injury, use a hoist or suitable lifting device when lifting crane mast locking cylinder.
- Fuel and oil are slippery and can cause falls. To avoid injury, wipe up spilled fuel or oil with rags.

REMOVAL

CAUTION

Cap or plug all ports and ends of hoses and tubes to prevent contamination of hydraulic oil. Failure to do so may result in damage to equipment.

NOTE

- Procedure is the same for both mast locking cylinders.
- Tag lines prior to disconnecting to aid in connecting.

1. DISCONNECT two HOSES (1 and 2). INSTALL CAPS or PLUGS.

CRANE MAST LOCKING CYLINDER REPLACEMENT (CONT)

2. REMOVE two capscrews (3 and 4), two lock nuts (5 and 6), two pins (7 and 8), and crane mast locking CYLINDER (9). DISCARD lock NUTS.
3. REMOVE ADAPTER (10) and packing (11). DISCARD PACKING.
4. REMOVE two FITTINGS (12 and 13).

INSTALLATION
NOTE

Procedure is the same for both mast locking cylinders.

1. INSTALL two FITTINGS (12 and 13).
2. INSTALL ADAPTER (10) and new packing (11).
3. INSTALL crane mast locking CYLINDER (9), two pins (7 and 8), two capscrews (3 and 4), and two new lock nuts (5 and 6).
4. REMOVE CAPS or PLUGS. CONNECT two HOSES (1 and 2).

NOTE

Follow-on Maintenance:
Check rear hydraulic tank (TM 5-2420-224-10).

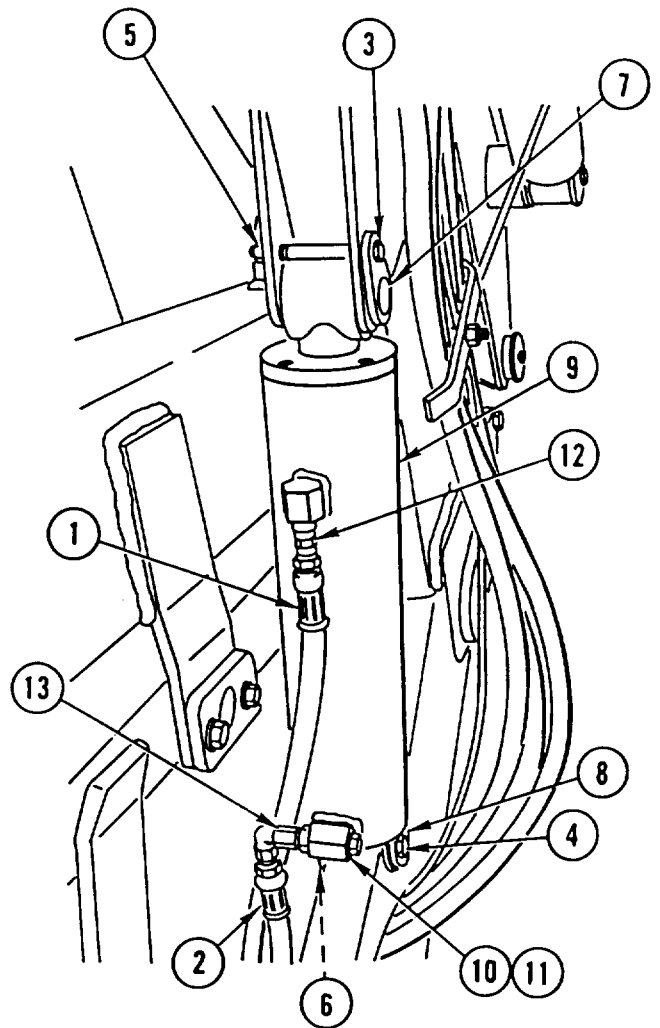

CRANE OUTER BOOM CYLINDER REPLACEMENT

This task covers: a. Removal b. Installation

INITIAL SETUP

Applicable Configuration:

HMMH

Tools and Special Equipment:

Shop Equipment, SC 4910-95-CL-A74
Tool Kit, SC 5180-90-CL-N26

Materials/Parts:

Packing (2)

Caps and Plugs Appendix C, item 7

Rags Appendix C, item 32

Personnel Required: (2)

References:

TM 5-2420-224-10

Equipment Condition:

Reference	Condition Description
Page 2-23	Crane in Three-Point Stance
Page 2-23	Hydraulic Pressure Relieved

General Safety Instructions:

WARNING

- High pressure hydraulics [oil under 2450 psi (16,893 kPa)] operate this equipment. Never disconnect any hydraulic line or fitting without first dropping pressure to zero. A high pressure oil stream can pierce body and cause severe injury to personnel.
- Crane outer boom cylinder weighs 219 pounds (100 kilograms). To avoid personal injury, use a hoist or suitable lifting device when lifting crane outer boom cylinder.
- Fuel and oil are slippery and can cause falls. To avoid injury, wipe up spilled fuel or oil with rags.

CRANE OUTER BOOM CYLINDER REPLACEMENT (CONT)

REMOVAL**CAUTION**

Cap or plug all ports and ends of hoses and tubes to prevent contamination of hydraulic oil. Failure to do so may result in damage to equipment.

NOTE

Tag lines prior to disconnecting to aid in connecting.

DISCONNECT two hydraulic HOSES (1). INSTALL CAPS or PLUGS.

REMOVE capscrew (2), washer (3), and PIN (4) from cylinder end (5).

REMOVE capscrew (6), washer (7), pin (8), and outer boom CYLINDER (9) from rod end (10).

REMOVE two FITTINGS (11) and two packings (12). INSTALL CAPS or PLUGS. DISCARD PACKINGS.

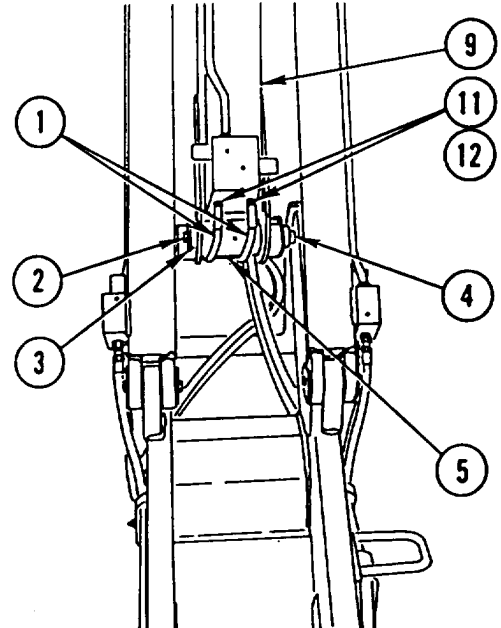
**INSTALLATION**

1. REMOVE CAPS or PLUGS. INSTALL two new packings (12) and two FITTINGS (11) in outer boom cylinder (9).
2. INSTALL rod END (10) of outer boom cylinder (9), pin (8), washer (7), and capscrew (6).
3. INSTALL cylinder END (5), pin (4), washer (3), and capscrew (2).
4. REMOVE CAPS or PLUGS. CONNECT two hydraulic HOSES (1).

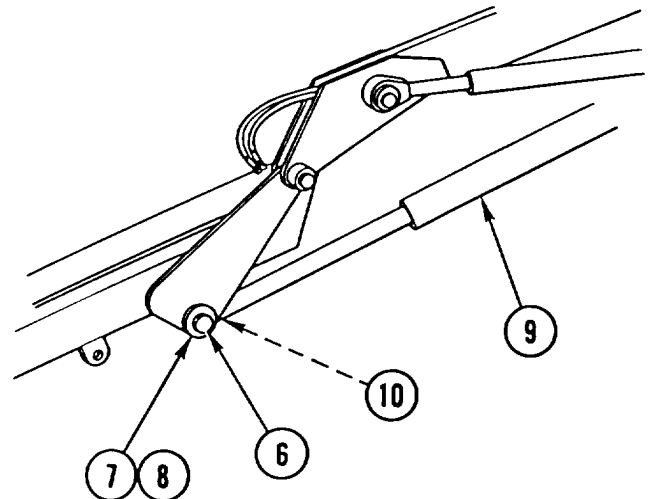
**NOTE**

Follow-on Maintenance:

Check rear hydraulic tank (TM 5-2420-224-10).

CRANE HORIZONTAL OUTRIGGER CYLINDER REPLACEMENT

This task covers: a. Removal b. Installation

INITIAL SETUP

Applicable Configuration:

HMMH

Tools and Special Equipment:

Shop Equipment, SC 4910-95-CL-A74
Tool Kit, SC 5180-90-CL-N26

Materials/Parts:

Washer, Lock

Nut, Lock

Caps and Plugs Appendix C, Item 7

Rags Appendix C, Item 32

References:

TM 5-2420-224-10

Equipment Condition:

Reference	Condition Description
Page 2-23	Crane in Three-Point Stance
Page 2-23	Hydraulic Pressure Relieved

General Safety Instructions:

WARNING

- High pressure hydraulics [oil under 2450 psi (16,893 kPa)] operate this equipment. Never disconnect any hydraulic line or fitting without first dropping pressure to zero. A high pressure oil stream can pierce body and cause severe injury to personnel.
- Fuel and oil are slippery and can cause falls. To avoid injury, wipe up spilled fuel or oil with rags.

REMOVAL

CAUTION

Cap or plug all ports and ends of hoses and tubes to prevent contamination of hydraulic oil. Failure to do so may result in damage to equipment.

NOTE

- Procedure is the same for both horizontal outrigger cylinders.
- Tag lines prior to disconnecting to aid in connecting.

CRANE HORIZONTAL OUTRIGGER CYLINDER REPLACEMENT (CONT)

1. DISCONNECT two HOSES (1 and 2). INSTALL CAPS or PLUGS.
2. REMOVE CAPSCREW (3) and lock washer (4). DISCARD lock WASHER.
3. REMOVE capscrew (5), lock nut (6), and horizontal outrigger CYLINDER (7). DISCARD lock NUT.
4. REMOVE two FITTINGS (8 and 9).

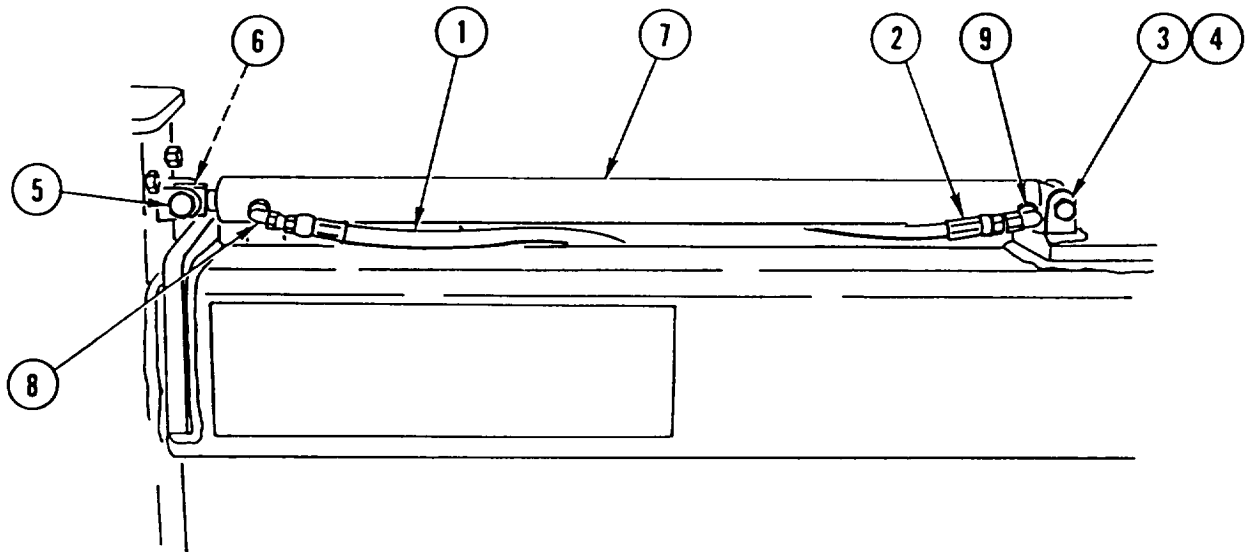
INSTALLATION
NOTE

Procedure is the same for both horizontal outrigger cylinders.

1. INSTALL two FITTINGS (8 and 9).
2. INSTALL horizontal outrigger CYLINDER (7), capscrew (5), and new lock nut (6).
3. INSTALL CAPSCREW (3) and new lock washer (4).
4. REMOVE CAPS or PLUGS. CONNECT two HOSES (1 and 2).

NOTE

Follow-on Maintenance:
Check rear hydraulic tank (TM 5-2420-224-10).

CRANE VERTICAL OUTRIGGER CYLINDER REPLACEMENT

This task covers: a. Removal b. Installation

INITIAL SETUP

Applicable Configuration:

HMMH

General Safety Instructions:

Tools and Special Equipment:

Shop Equipment, SC 4910-95-CL-A74
 Tool Kit, SC 5180-90-CL-N26

Materials/Parts:

Packing (2)

Caps and Plugs Appendix C, Item 7

Rags Appendix C, Item 32

Personnel Required: (2)

References:

TM 5-2420-224-10

Equipment Condition:

Reference	Condition Description
Page 2-23	Crane in Three-Point Stance
TM 5-2420-224-10	Outrigger Leg Lowered to Ground
Page 2-23	Hydraulic Pressure Relieved

W A R N I N G

- High pressure hydraulics [oil under 2450 psi (16,893 kPa)] operate this equipment. Never disconnect any hydraulic line or fitting without first dropping pressure to zero. A high pressure oil stream can pierce body and cause severe injury to personnel.
- Crane outrigger leg assembly weighs approximately 65 pounds (30 kilograms). To avoid personal injury, use a hoist or suitable lifting device when lifting crane outrigger leg assembly.
- Fuel and oil are slippery and can cause falls. To avoid injury, wipe up spilled fuel or oil with rags.

REMOVAL

CAUTION

Cap or plug all ports and ends of hoses and tubes to prevent contamination of hydraulic oil. Failure to do so may result in damage to equipment.

NOTE

- Procedure is the same for both vertical outrigger cylinders.
- Tag lines prior to disconnecting to aid in connecting.

CRANE VERTICAL OUTRIGGER CYLINDER REPLACEMENT (CONT)

1. DISCONNECT two hydraulic HOSES (1).
INSTALL CAPS or PLUGS.
2. REMOVE two BOLTS (2) holding leg assembly (3) to arm (4) and REMOVE LEG assembly (3).
3. REMOVE PIN (5) holding rod end of vertical outrigger cylinder (6) to leg (7) and REMOVE LEG (7).
4. REMOVE two FITTINGS (8) and two packings (9). DISCARD PACKINGS.
5. REMOVE two BOLTS (10) holding vertical outrigger cylinder (6) to sleeve (11) and REMOVE vertical outrigger CYLINDER (6) from sleeve (11).

INSTALLATION

NOTE

Procedure is the same for both vertical outrigger cylinders.

1. INSTALL two new packings (9) and two FITTINGS (8).
2. INSTALL vertical outrigger CYLINDER (6) in sleeve (11) and INSTALL two BOLTS (10).
3. INSTALL LEG (7) and pin (5) through rod end of vertical outrigger cylinder (6).
4. INSTALL LEG assembly (3) on arm (4) and INSTALL two BOLTS (2).
5. REMOVE CAPS or PLUGS. CONNECT two hydraulic HOSES (1).

NOTE

Follow-on Maintenance:

Check rear hydraulic tank (TM 5-2420-224-10).

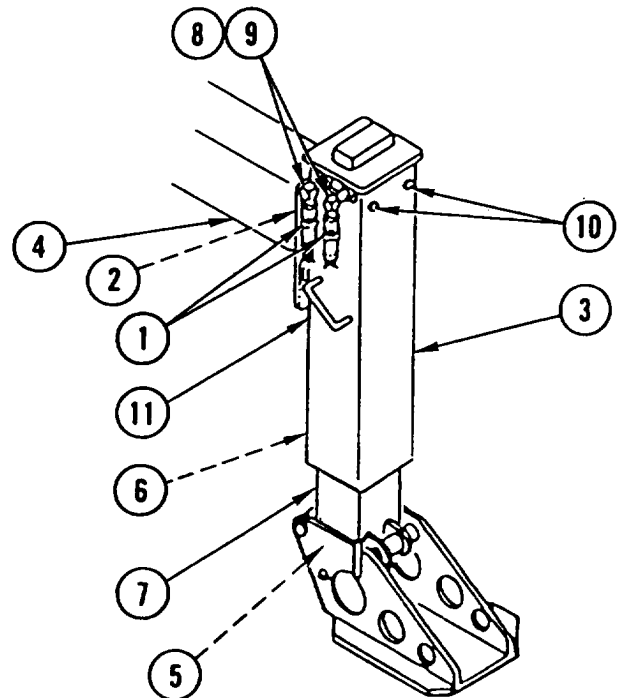

FRONT HYDRAULIC TANK REPLACEMENT AND REPAIR

This task covers: a. Removal b. Disassembly c. Assembly d. Installation

INITIAL SETUP

Tools and Special Equipment:

Shop Equipment, SC 4910-95-CL-A74
Tool Kit, SC 5180-90-CL-N26

Materials/Parts:

Packing

Washer, Lock (4)

Gasket

Packing (2)

Packing

Packing

Caps and Plugs Appendix C, Item 7

Rags Appendix C, Item 32

Personnel Required: (2)

References:

None

Equipment Condition:

Reference	Condition Description
Page 2-22 or 2-23	Backhoe (SEE) or Crane (HMMH) in Three-Point Stance
Page 2-14	Front Hydraulic Tank Drained
Page 2-23	Hydraulic Pressure Relieved

General Safety Instructions:

WARNING

- High pressure hydraulics [oil under 2450 psi (16,893 kPa)] operate this equipment. Never disconnect any hydraulic line or fitting without first dropping pressure to zero. A high pressure oil stream can pierce body and cause severe injury to personnel.
- Front hydraulic tank assembly weighs 98 pounds (45 kilograms). To avoid personal injury, use a hoist or suitable lifting device when lifting front hydraulic tank assembly.
- Fuel and oil are slippery and can cause falls. To avoid injury, wipe up spilled fuel or oil with rags.

FRONT HYDRAULIC TANK REPLACEMENT AND REPAIR (CONT)

REMOVAL**CAUTION**

Cap or plug all ports and ends of hoses and tubes to prevent contamination of hydraulic oil. Failure to do so may result in damage to equipment.

NOTE

- Procedure is the same for both vehicles.
 - Tag all lines prior to disconnecting to aid in connecting.
1. DISCONNECT HOSE (1). INSTALL CAP or PLUG.
 2. REMOVE elbow (2) and COUPLING (3).
 3. DISCONNECT HOSE (4). INSTALL CAP or PLUG.
 4. REMOVE ELBOW (5) and packing (6). DISCARD PACKING.
 5. REMOVE four BOLTS (7) and four lock washers (8). DISCARD lock WASHERS.

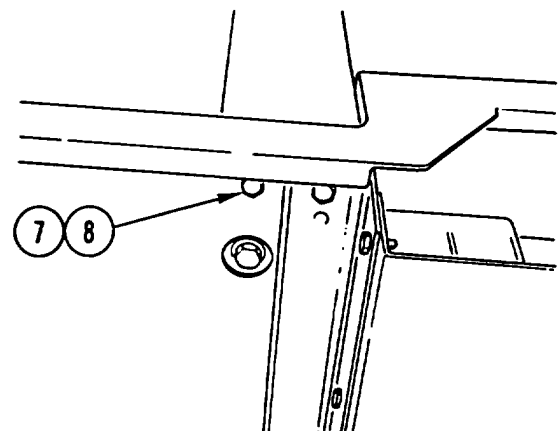
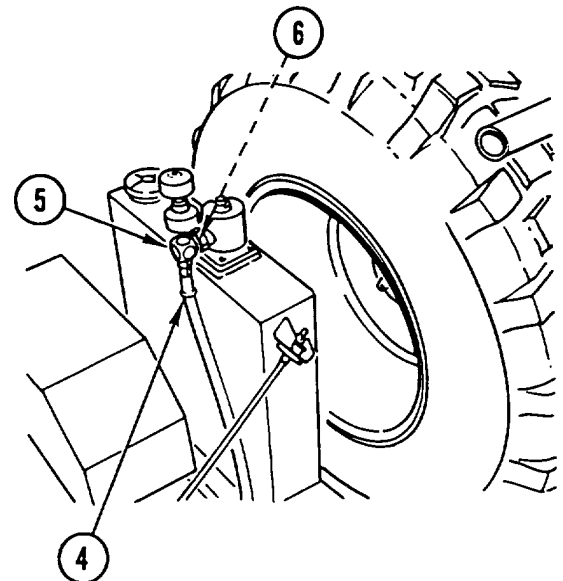
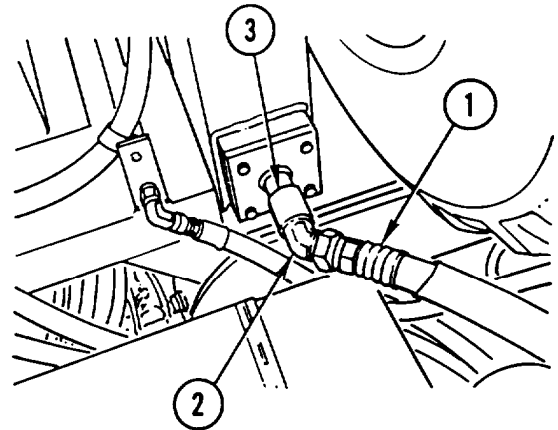

FRONT HYDRAULIC TANK REPLACEMENT AND REPAIR (CONT)

6. REMOVE NUT (9) and washer.
7. LIFT front hydraulic TANK assembly (11) off vehicle.

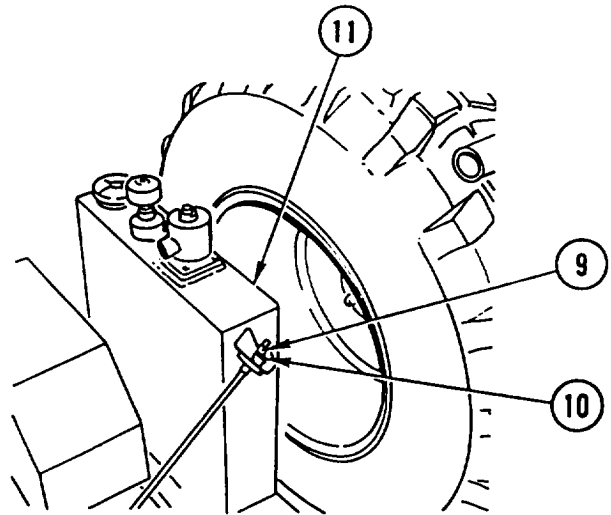

DISASSEMBLY

1. REMOVE four bolts (1), support (2), gasket (3), and FILTER (4). DISCARD GASKET.
2. REMOVE PLUG (5).

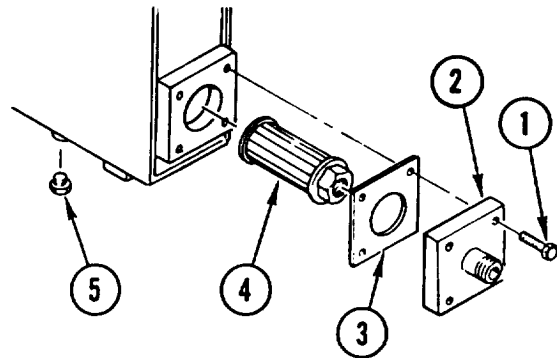

3. REMOVE six screws (6), plate (7), and INDICATOR (8).
4. REMOVE cap (9), chain (10), and strainer BODY (11).
5. REMOVE FILTER (12).

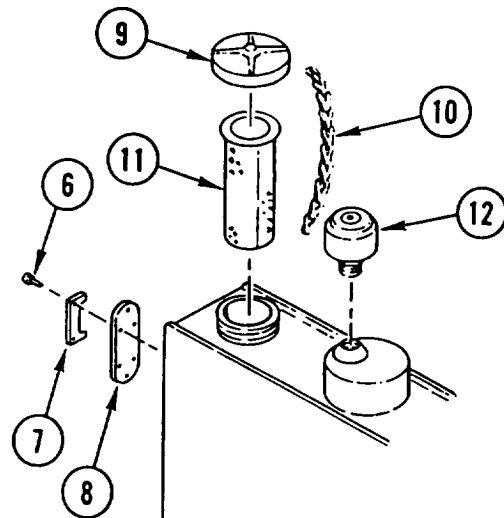

FRONT HYDRAULIC TANK REPLACEMENT AND REPAIR (CONT)

6. REMOVE cover (13), OUTLET (14), two packings (15), head (16), and packing (17). DISCARD PACKINGS.
7. REMOVE VALVE (18).
8. REMOVE ring (19) and FILTER (20).

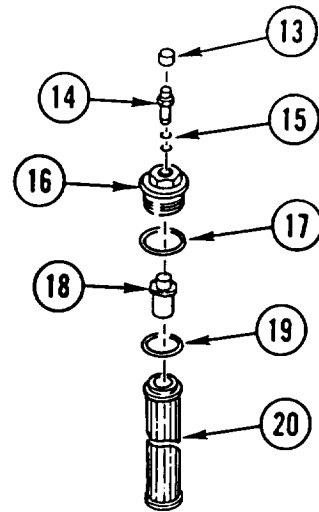

9. REMOVE four SCREWS (21).
10. REMOVE fitter HOUSING (22) and packing (23). DISCARD PACKING.

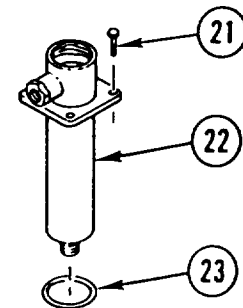

ASSEMBLY

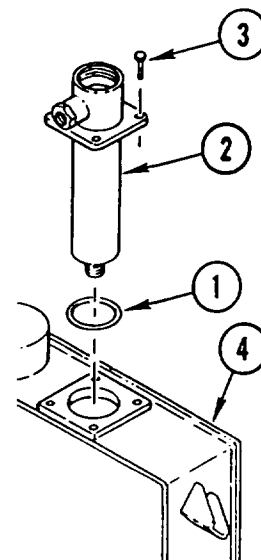
1. INSTALL new packing (1), filter HOUSING (2), and four screws (3) in front hydraulic tank (4).

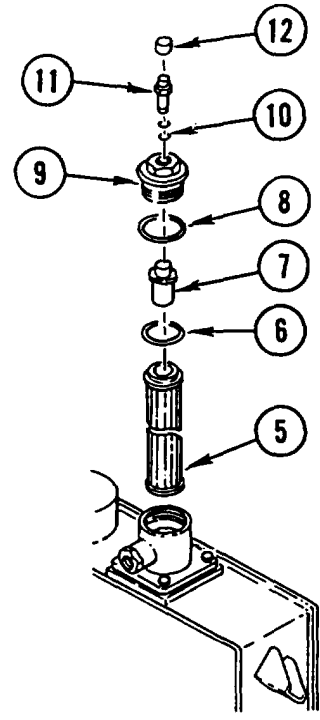

FRONT HYDRAULIC TANK REPLACEMENT AND REPAIR (CONT)

2. INSTALL FILTER (5) and ring (6).
3. INSTALL VALVE (7), new packing (8), and head (9).
4. INSTALL two new packings (10), OUTLET (11), and cover (12).



5. INSTALL FILTER (13).
6. INSTALL strainer BODY (14), chain (15), and cap (16).
7. INSTALL INDICATOR (17), plate (18), and six screws (19).

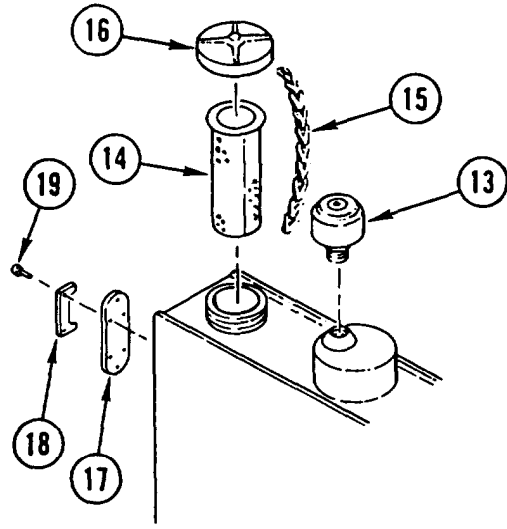

FRONT HYDRAULIC TANK REPLACEMENT AND REPAIR (CONT)

8. INSTALL PLUG (20).
9. INSTALL new gasket (21), FILTER (22), support (23), and four bolts (24).

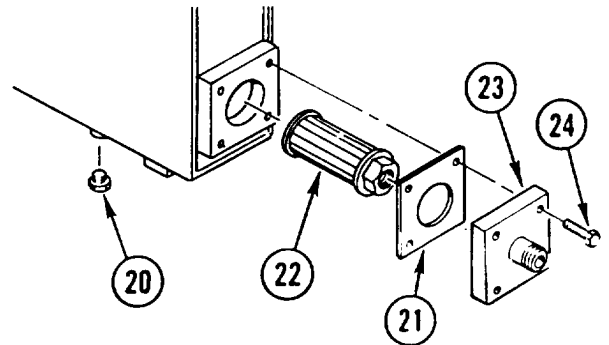

INSTALLATION

NOTE

Procedure is the same for both vehicles.

1. POSITION front hydraulic TANK assembly (1) on vehicle.
2. INSTALL washer (2) and NUT (3)

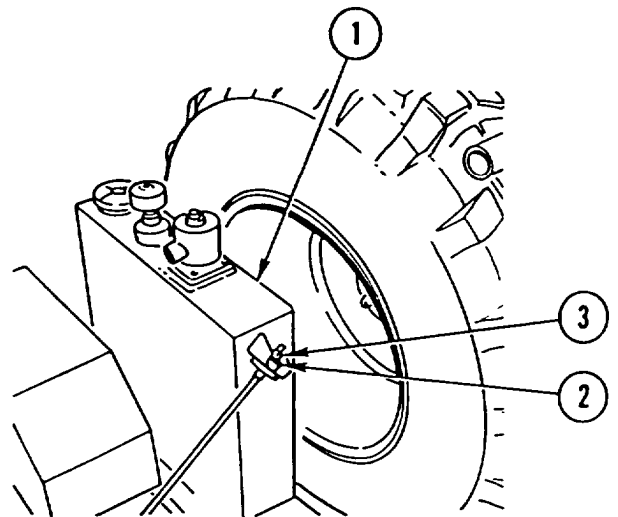

3. INSTALL four new lock washers (4) and four BOLTS (5).

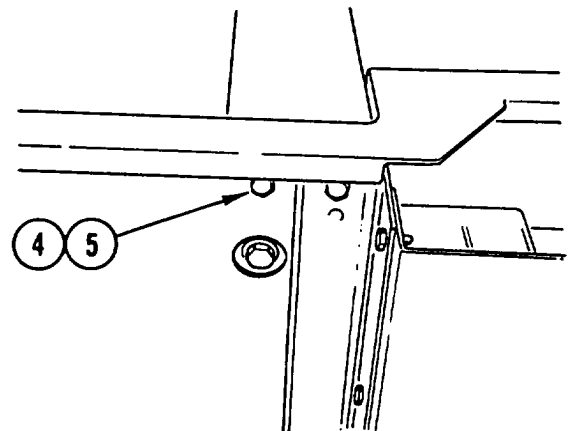

FRONT HYDRAULIC TANK REPLACEMENT AND REPAIR (CONT)

4. INSTALL ELBOW (6) and new packing (7).
5. REMOVE CAP or PLUG. CONNECT HOSE (8).

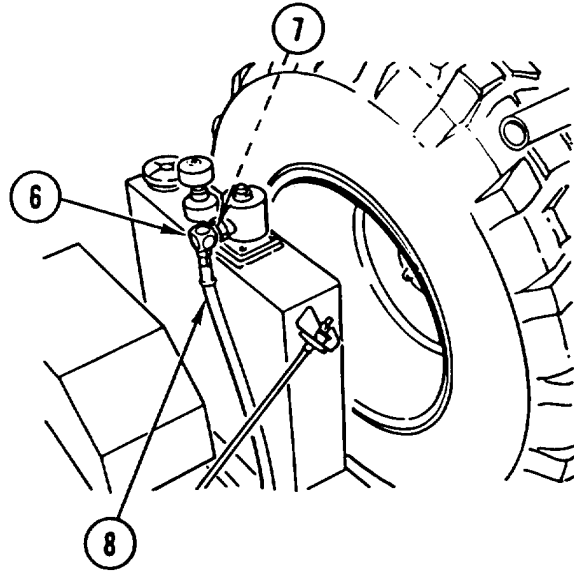

6. INSTALL COUPLING (9) and elbow (10).
7. REMOVE CAP or PLUG. CONNECT HOSE (11).

NOTE

Follow-on Maintenance:
Fill front hydraulic tank (page 2-14).

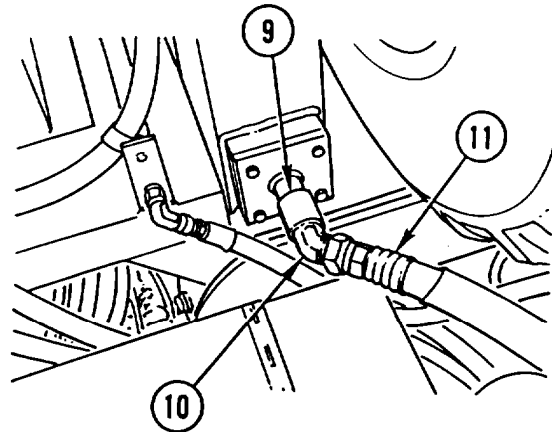

FRONT HYDRAULIC TANK FILTER REPLACEMENT

This task covers: a. Removal b. Cleaning c. installation

INITIAL SETUP

Tools and Special Equipment:

Shop Equipment, SC 4910-95-CL-A74
 Tool Kit, SC 5180-90-CL-N26

General Safety Instructions:

Materials/Parts:

Filter, Air
 Packing
 Filter, Fluid
 Gasket
 Caps and Plugs Appendix C, item 7
 Rags Appendix C, item 32

References:

None

Equipment Condition:

Reference	Condition Description
Page 2-22 or 2-23	Backhoe (SEE) or Crane (HMMH) in Three-Point Stance
Page 2-14	Front Hydraulic Tank Drained
Page 2-23	Hydraulic Pressure Relieved

W A R N I N G

- High pressure hydraulics [oil under 2450 psi (16,893 kPa)] operate this equipment. Never disconnect any hydraulic line or fitting without first dropping pressure to zero. A high pressure oil stream can pierce body and cause severe injury to personnel.
- Fuel and oil are slippery and can cause falls. To avoid injury, wipe up spilled fuel or oil with rags.

FRONT HYDRAULIC TANK FILTER REPLACEMENT (CONT)

REMOVAL

NOTE

Procedure is the same for both vehicles.

1. REMOVE and DISCARD air FILTER (1).
2. REMOVE HEAD (2) and packing (3). DISCARD PACKING.
3. REMOVE VALVE (4).
4. REMOVE retaining ring (5) and fluid FILTER (6). DISCARD fluid FILTER.

CAUTION

Cap or plug all ports and ends of hoses and tubes to prevent contamination of hydraulic oil. Failure to do so may result in damage to equipment.

5. DISCONNECT hydraulic HOSE (7). INSTALL CAP or PLUG.
6. REMOVE elbow (8) and COUPLING (9).
7. REMOVE four bolts (10), support (11), gasket (12), and FILTER (13). DISCARD GASKET.

CLEANING

Clean filter.

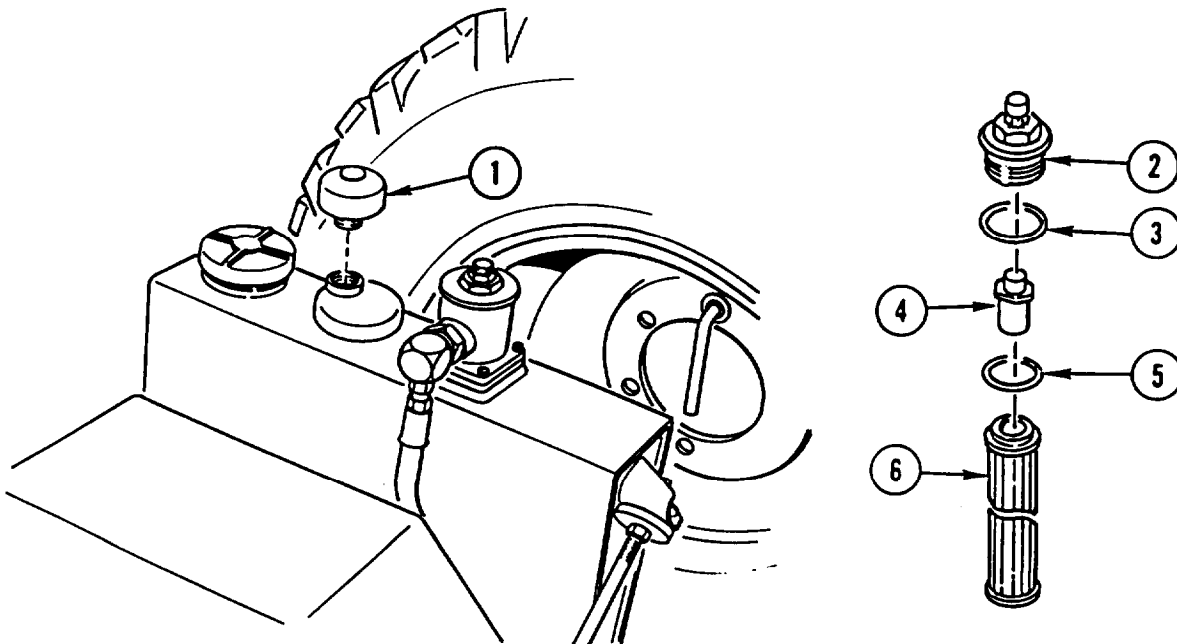

FRONT HYDRAULIC TANK FILTER REPLACEMENT (CONT)

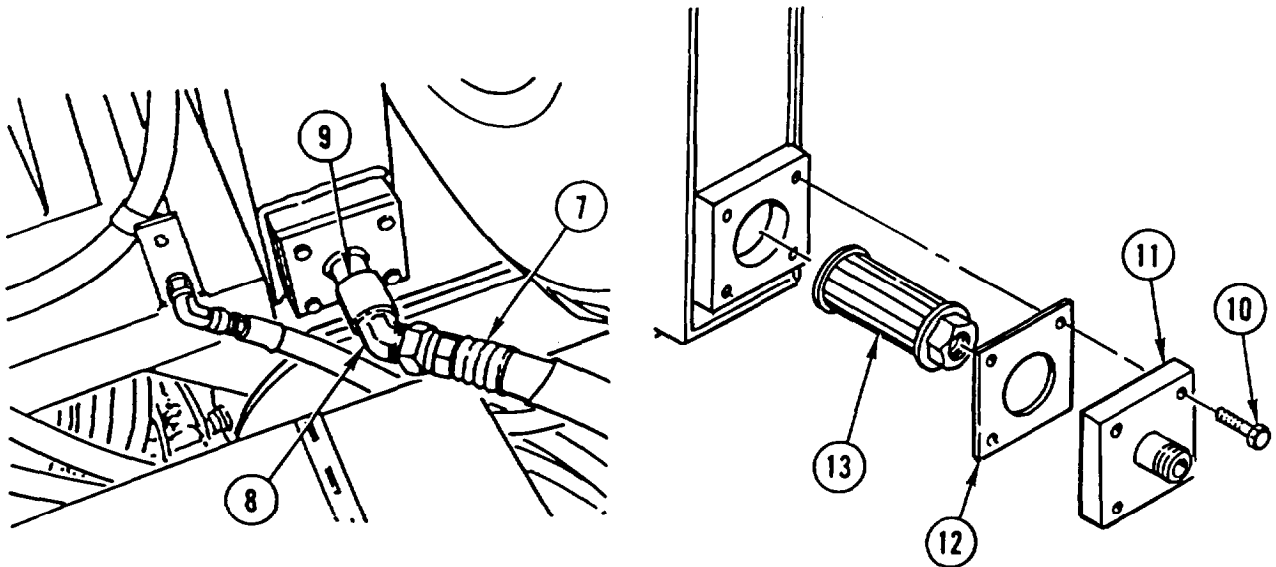
**INSTALLATION****NOTE**

Procedure is the same for both vehicles.

1. INSTALL FILTER (13), new gasket (12), support (11), and four bolts (10).
2. INSTALL COUPLING (9) and elbow (8).
3. REMOVE CAP or PLUG. CONNECT hydraulic HOSE (7).
4. INSTALL new fluid FILTER (6) and retaining ring (5).
5. INSTALL VALVE (4).
6. INSTALL new packing (3) and HEAD (2).
7. INSTALL new air FILTER (1).

NOTE

Follow-on Maintenance:
Fill front hydraulic tank (page 2-14).

REAR HYDRAULIC TANK REPLACEMENT AND REPAIR (CONT)

1. DISCONNECT HOSE (1). INSTALL CAP or PLUG.
2. REMOVE elbow (2) and COUPLING (3).
3. DISCONNECT HOSE (4). INSTALL CAP or PLUG.
4. REMOVE ELBOW (5), packing (6), adapter (7), and adapter (8). DISCARD PACKING.

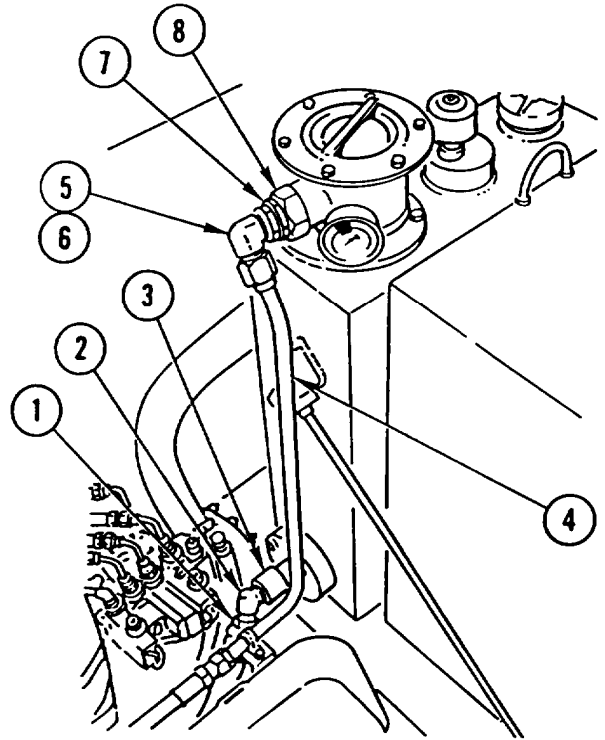

5. REMOVE four BOLTS (9) and four washers (10) from bottom of rear hydraulic tank assembly (11).

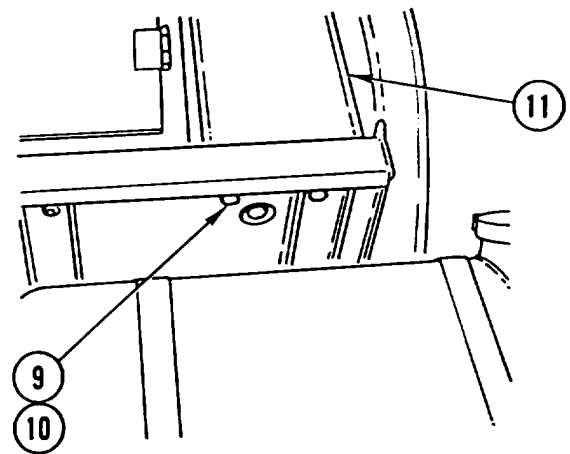

REAR HYDRAULIC TANK REPLACEMENT AND REPAIR (CONT)

6. REMOVE NUT (12) and washer (13).
7. LIFT rear hydraulic TANK assembly (11) off vehicle.

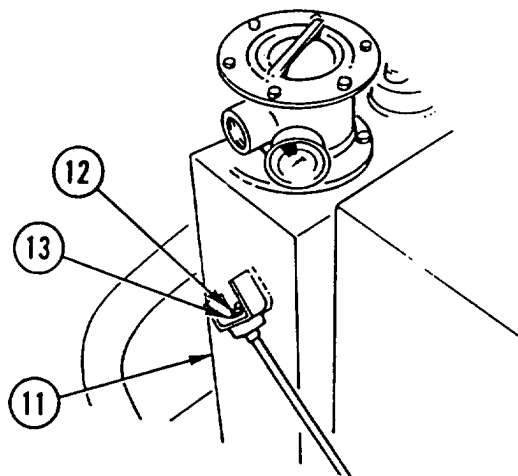

DISASSEMBLY

1. REMOVE six screws (1), support (2), gasket (3), and STRAINER (4). DISCARD GASKET.
2. REMOVE PLUG (5).

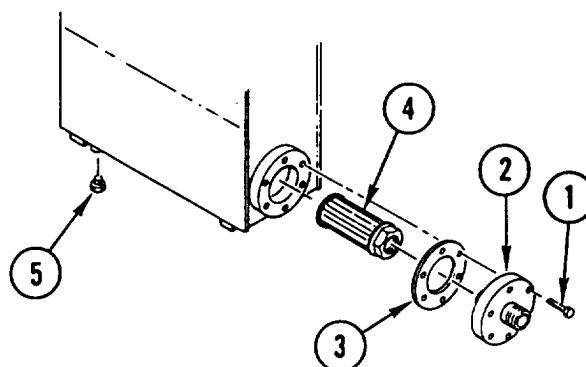

3. REMOVE six screws (6), plate (7), and INDICATOR (8).
4. REMOVE cap (9), chain (10), and strainer ELEMENT (11).
5. REMOVE FILTER (12).

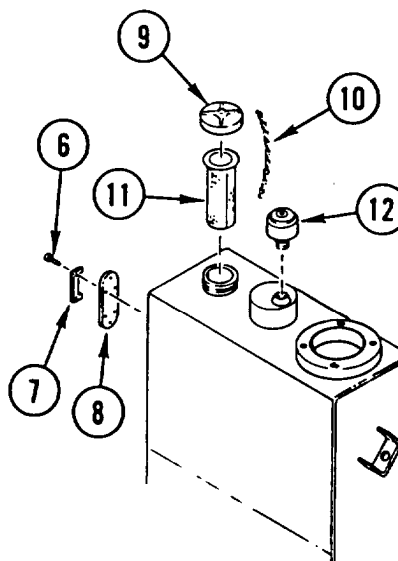

REAR HYDRAULIC TANK REPLACEMENT AND REPAIR (CONT)

6. REMOVE six screws (13), six nuts (14), COVER (15), and gasket (16). DISCARD GASKET.
7. REMOVE manifold (17) and FILTER (18).
8. REMOVE GAGE (19).

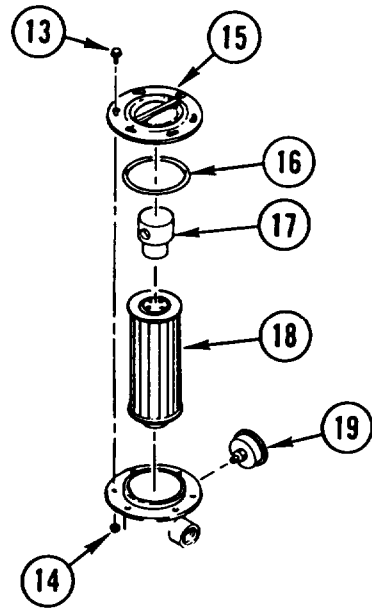

9. IF DAMAGED, REMOVE identification LABEL (20).
10. REMOVE four screws (21), HOUSING (22), and gasket (23) from rear hydraulic tank (24). DISCARD GASKET.

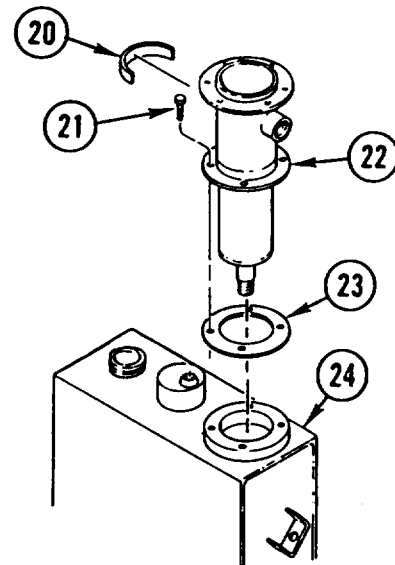

REAR HYDRAULIC TANK REPLACEMENT AND REPAIR (CONT)

ASSEMBLY

1. IF REMOVED, INSTALL new identification LABEL (1).
2. INSTALL new GASKET (2) on rear hydraulic tank (3).
3. INSTALL HOUSING (4) and four screws (5).

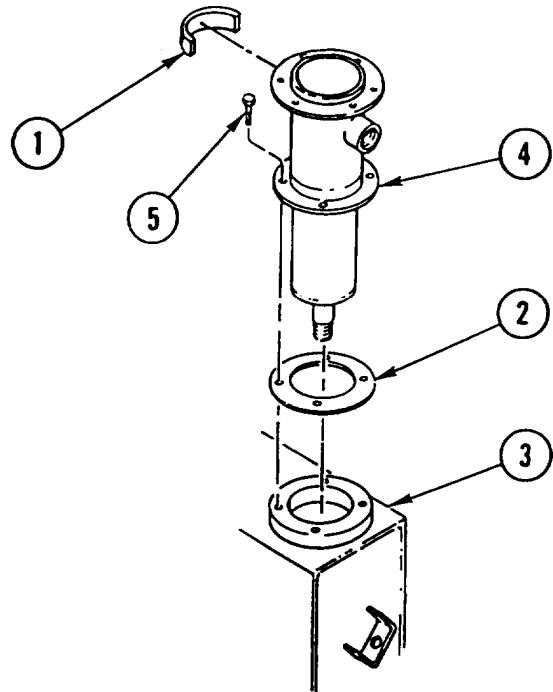

4. INSTALL GAGE (6).
5. INSTALL FILTER (7) and manifold (8).
6. INSTALL new gasket (9), COVER (10), six screws (11), and six nuts (12).

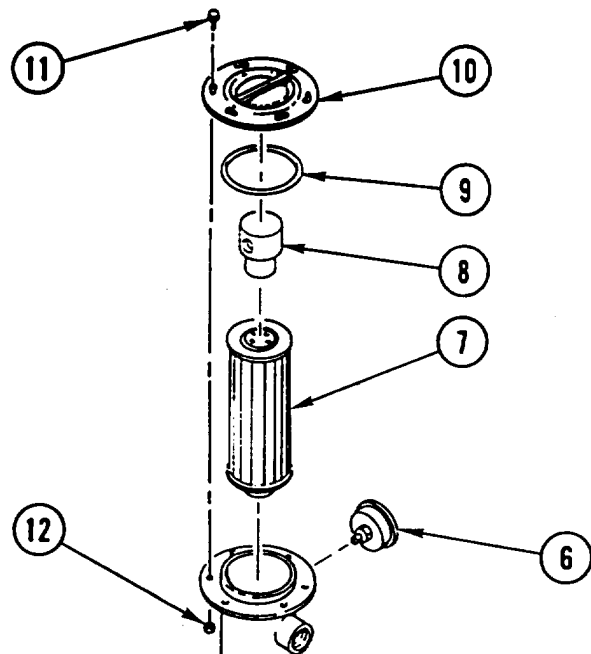

REAR HYDRAULIC TANK REPLACEMENT AND REPAIR (CONT)

7. INSTALL FILTER (13).
8. INSTALL strainer ELEMENT (14), chain (15), and cap (16).
9. INSTALL INDICATOR (17), plate (18), and six screws (19).

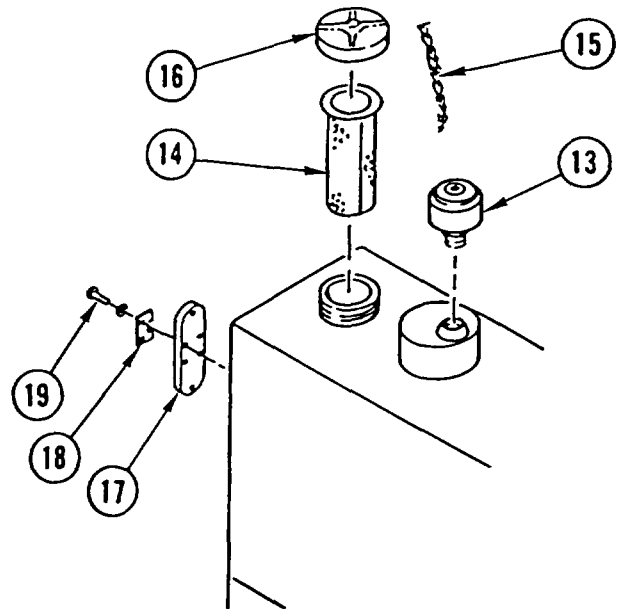

10. INSTALL new gasket (20), STRAINER (21), support (22), and six screws (23).
11. INSTALL PLUG (24).

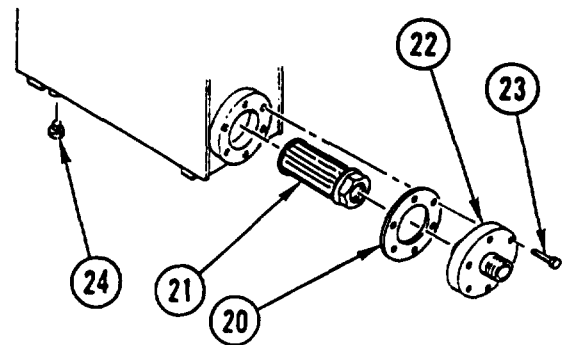

INSTALLATION

NOTE

Procedure is the same for both vehicles.

1. POSITION rear hydraulic TANK assembly (1) on vehicle.
2. INSTALL washer (2) and NUT (3).

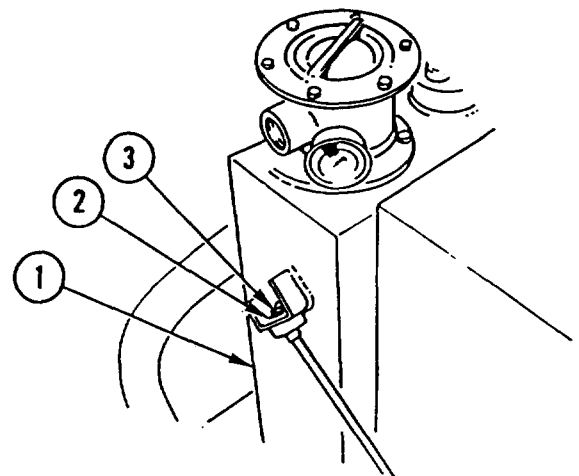

REAR HYDRAULIC TANK REPLACEMENT AND REPAIR (CONT)

3. INSTALL four washers (4) and four BOLTS (5).

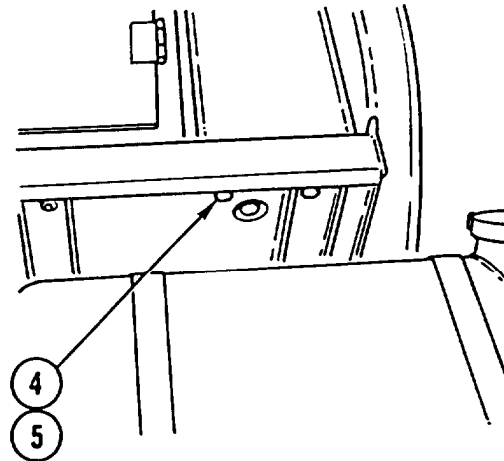

4. INSTALL adapter (6), adapter (7), new packing (8), and ELBOW (9).
5. REMOVE CAP or PLUG. CONNECT HOSE (10).
6. INSTALL COUPLING (11) and elbow (12).
7. REMOVE CAP or PLUG. CONNECT HOSE (13).

NOTE

Follow-on Maintenance:
Fill rear hydraulic tank (page 2-14).

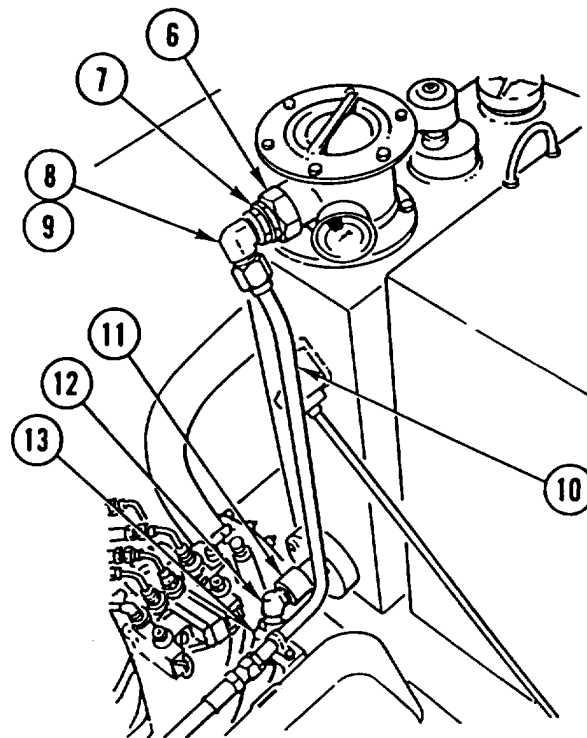

HYDRAULIC TANK SIGHT INDICATOR REPLACEMENT

This task covers: a. Removal b. Installation

INITIAL SETUP

Tools and Special Equipment:

Shop Equipment, SC 4910-95-CL-A74
Tool Kit, SC 5180-90-CL-N26

Materials/Parts:

Rags Appendix C, Item 32

References:

TM 5-2420-224-10

General Safety Instructions:

WARNING

Fuel and oil are slippery and can cause falls. To avoid injury, wipe up spilled fuel or oil with rags.

REMOVAL

NOTE

Procedure is the same for both hydraulic tank sight indicators.

1. USING suitable CONTAINER, DRAIN hydraulic OIL to level below sight indicator (1).
2. REMOVE six screws (2), plate (3), and INDICATOR (1).

INSTALLATION

NOTE

Procedure is the same for both hydraulic tank sight indicators.

1. INSTALL INDICATOR (1), plate (3), and six screws (2).
2. FILL with hydraulic OIL to level between ADD and FULL marks on sight indicator (1) (TM 5-2420-224-10).

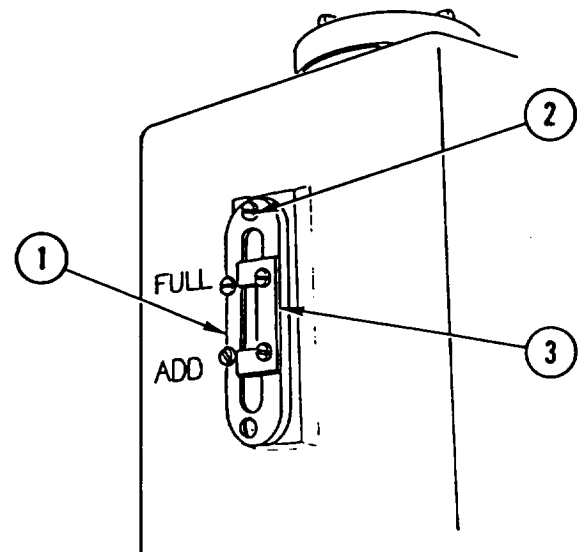

REAR HYDRAULIC TANK FILTER REPLACEMENT

This task covers: a. Removal b. Cleaning c. Installation

INITIAL SETUP

Tools and Special Equipment:

Shop Equipment, SC 4910-95-CL-A74
Tool Kit, SC 5180-90-CL-N26

General Safety Instructions:

Materials/Parts:

Breather

Filter, Fluid

Caps and Plugs Appendix C, Item 7

Rags Appendix C, Item 32

Equipment Condition:

Reference

Page 2-22 or 2-23

Condition Description

Backhoe (SEE) or Crane (HMMH) in Three Point Stance

Page 2-14

Rear Hydraulic Tank Drained

Page 2-23

Hydraulic Pressure Relieved

WARNING

- High pressure hydraulics [oil under 2450 psi (16,893 kPA)] operate this equipment. Never disconnect any hydraulic line or fitting without first dropping pressure to zero. A high pressure oil stream can pierce body and cause severe injury to personnel.
- Fuel and oil are slippery and can cause falls. To avoid injury, wipe up spilled fuel or oil with rags.

REMOVAL

NOTE

Procedure is the same for both vehicles.

1. REMOVE and DISCARD breather (1).

NOTE

Screws (2) are stacked to prevent removal. Nuts (3) are welded to filter housing.

2. LOOSEN six screws (2), and ROTATE cover (4).
 - 2.1. REMOVE cover (4) and gasket (5). DISCARD gasket.
3. REMOVE manifold (6) and fluid filter (7). DISCARD fluid FILTER.

REAR HYDRAULIC TANK FILTER REPLACEMENT (CONT)

CAUTION

Cap or plug all ports and ends of hose and tubes to prevent contamination of hydraulic oil. Failure to do so may result in damage to equipment.

4. DISCONNECT HOSE (8). INSTALL CAP or PLUG.
5. REMOVE ELBOW (9) and fitting (10).
6. Remove six screws (11), support (12), gasket (13), and STRAINER (14). DISCARD GASKET.

CLEANING

Clean strainer.

INSTALLATION

NOTE

Procedure is the same for both vehicles.

1. INSTALL STRAINER (14), new gasket (13), support (12), and six screws (11).
2. INSTALL fitting (10) and ELBOW (9).
3. REMOVE CAP or PLUG. CONNECT HOSE (8).
4. INSTALL new fluid FILTER (7) and manifold (6).
5. INSTALL new gasket (5), COVER (4), and tighten six screws (2).
6. INSTALL new breather (1).

NOTE

Follow-on Maintenance:
Fill rear hydraulic tank (page 2-14).

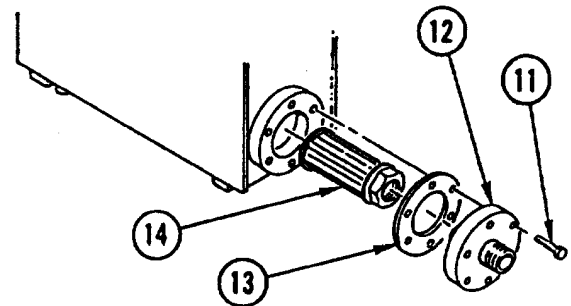
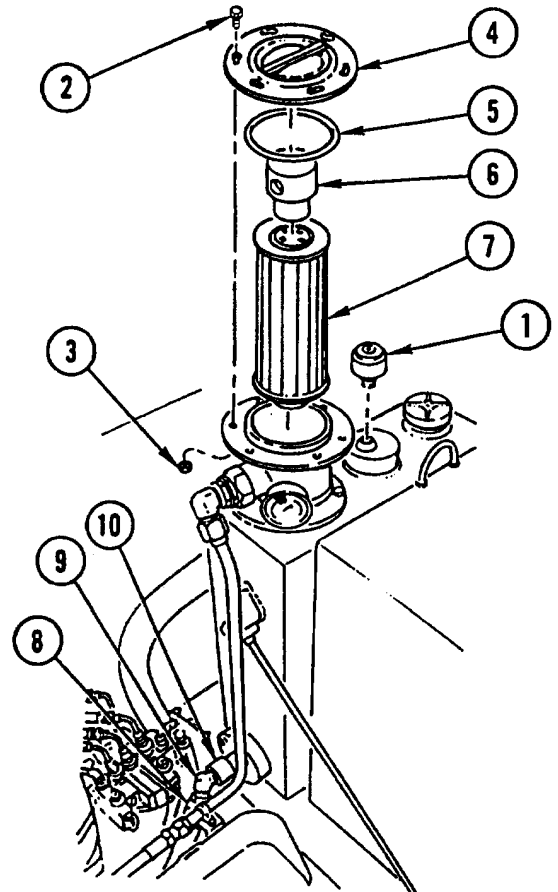

HYDRAULIC OIL COOLER REPLACEMENT

This task covers: a. Removal b. Installation

INITIAL SETUP

Tools and Special Equipment:

Shop Equipment, SC 4910-95-CL-A74
Tool Kit, SC 5180-90-CL-N26

Materials/Parts:

Packing (2)

Packing (2)

Caps and Plugs Appendix C, Item 7

Rags Appendix C, Item 32

Personnel Required: (2)

References:

TM 5-2420-224-10

Equipment Condition:

Reference	Condition Description
Page 2-22 or 2-23	Backhoe (SEE) or Crane (HMMH) in Three-Point Stance
Page 2-23	Hydraulic Pressure Relieved

General Safety Instructions:

WARNING

- High pressure hydraulics [oil under 2450 psi (16,893 kPa)] operate this equipment. Never disconnect any hydraulic line or fitting without first dropping pressure to zero. A high pressure oil stream can pierce body and cause severe injury to personnel.
- Do not connect or disconnect any electrical connector unless vehicle MASTER disconnect switch is OFF. To do so could result in injury to personnel.
- Hydraulic oil cooler weighs 85 pounds (39 kilograms). To avoid personal injury, use a hoist or suitable lifting device when lifting hydraulic oil cooler.
- Fuel and oil are slippery and can cause falls. To avoid injury, wipe up spilled fuel or oil with rags.

HYDRAULIC OIL COOLER REPLACEMENT (CONT)

REMOVAL

NOTE

Procedure is the same for both vehicles.

1. REMOVE five SCREWS (1) and MOVE control TOWER (2) aside.
2. REMOVE two screws (3) and COVER (4).

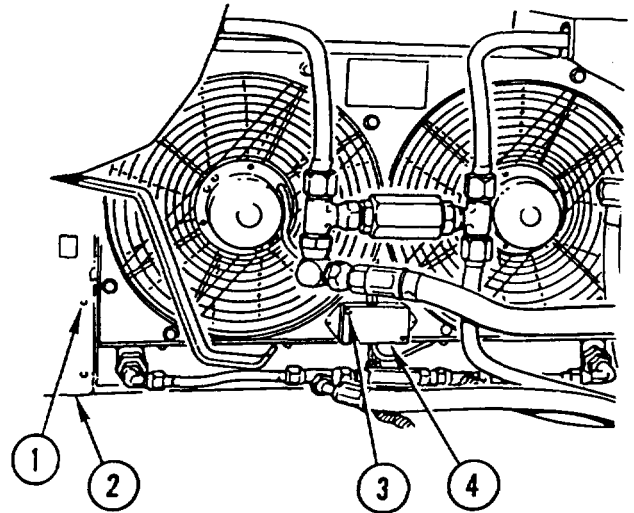

NOTE

Tag electrical leads prior to disconnecting to aid in connecting.

3. DISCONNECT four electrical LEADS (5).

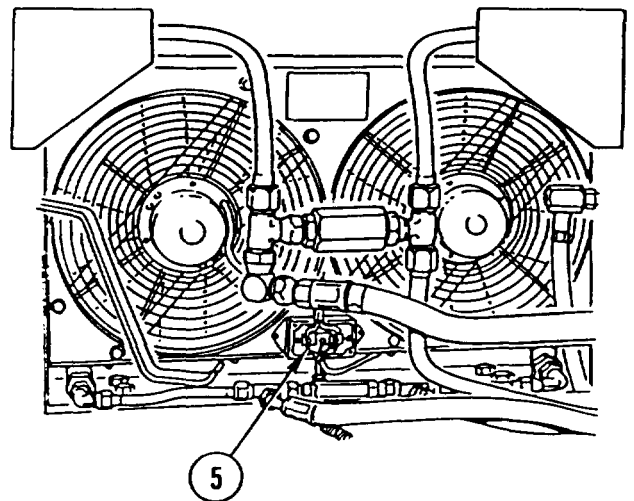

4. REMOVE two screws (6), washer (7), and GUARD (8).
5. REMOVE two screws (9), washer (10), and GUARD (11).

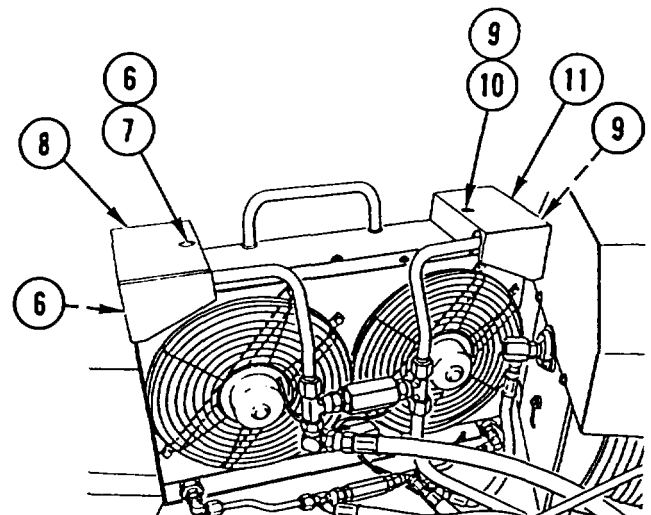

HYDRAULIC OIL COOLER REPLACEMENT (CONT)

CAUTION

Cap or plug all ports and ends of hoses and tubes to prevent contamination of hydraulic oil. Failure to do so may result in damage to equipment.

NOTE

Tag all lines prior to disconnecting to aid in connecting.

6. DISCONNECT lower TUBE (12) at two places. INSTALL CAPS or PLUGS.
7. DISCONNECT TUBE (13). INSTALL CAP or PLUG.
8. REMOVE ELBOW (14), adapter (15), and packing (16). DISCARD PACKING.
9. DISCONNECT TUBE (17), INSTALL CAP or PLUG.
10. REMOVE ELBOW (18), adapter (19), and packing (20). DISCARD PACKING.

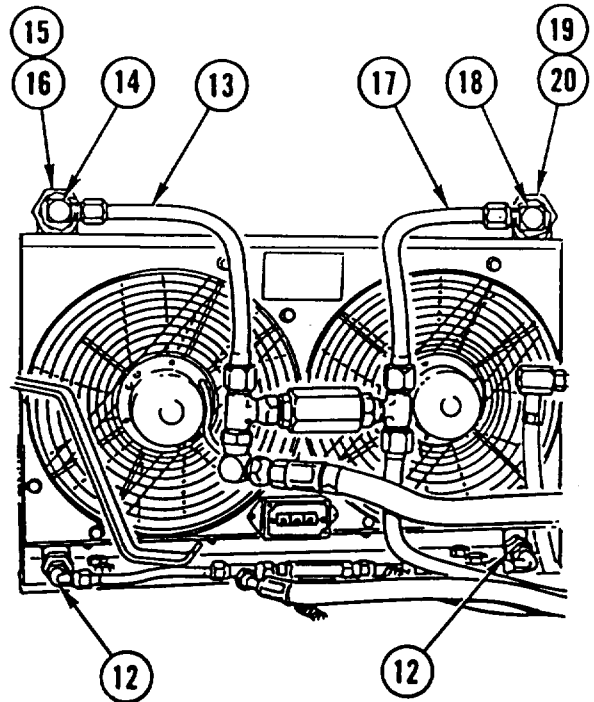

11. REMOVE four BOLTS (21) from underside of oil cooler (22).
12. REMOVE oil COOLER (22) from vehicle.
13. REMOVE two ADAPTERS (23) and two packings (24). DISCARD PACKINGS.

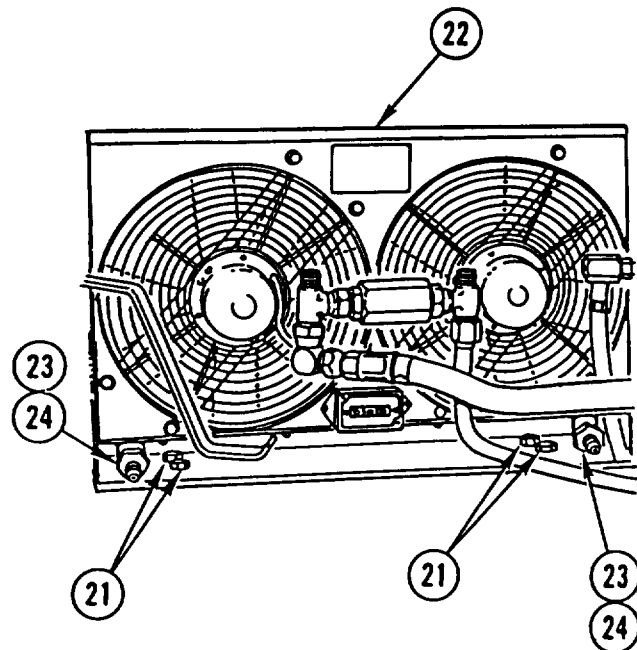

HYDRAULIC OIL COOLER REPLACEMENT (CONT)

INSTALLATION

NOTE

Procedure is the same for both vehicles.

1. INSTALL two new packings (1) and two ADAPTERS (2).
2. POSITION oil COOLER (3) on vehicle.
3. INSTALL four BOLTS (4) to underside of oil cooler (3).

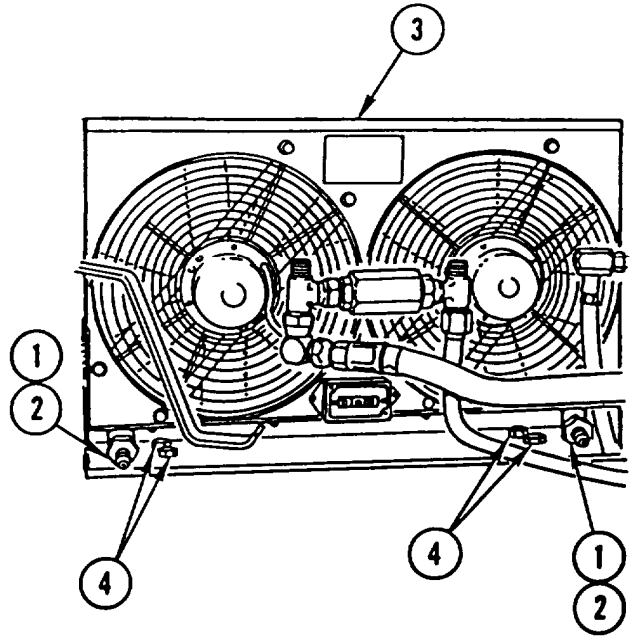

4. INSTALL new packing (5), ADAPTER (6), and elbow (7).
5. INSTALL new packing (8), ADAPTER (9), and elbow (10).
6. REMOVE CAPS or PLUGS. CONNECT TUBE (11) and TUBE (12).
7. REMOVE CAPS or PLUGS. CONNECT lower TUBE (13) at two places.

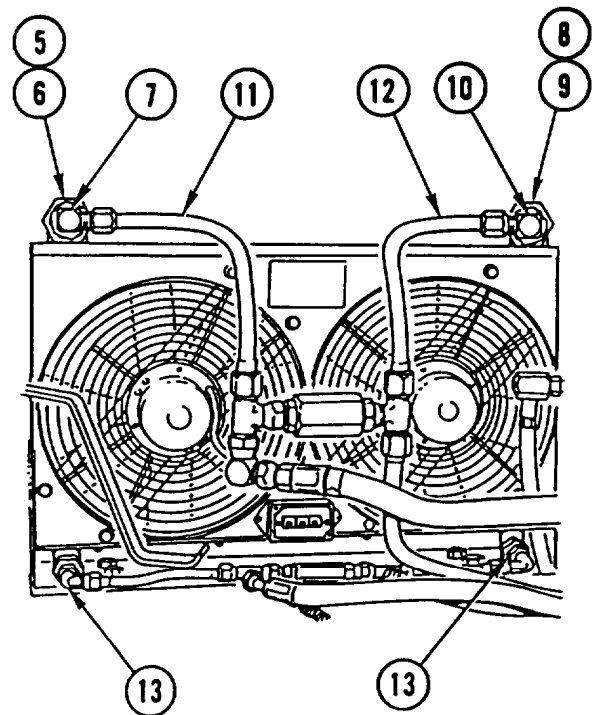

HYDRAULIC OIL COOLER REPLACEMENT (CONT)

8. INSTALL GUARD (14), two screws (15), and washer (16).
9. INSTALL GUARD (17), two screws (18), and washer (19).

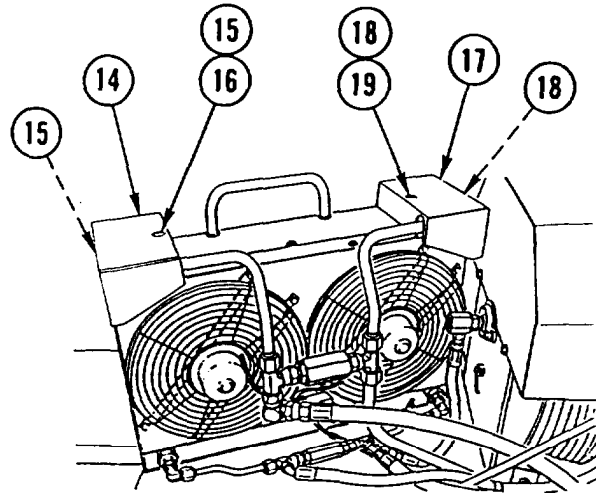

10. CONNECT four electrical LEADS (20).

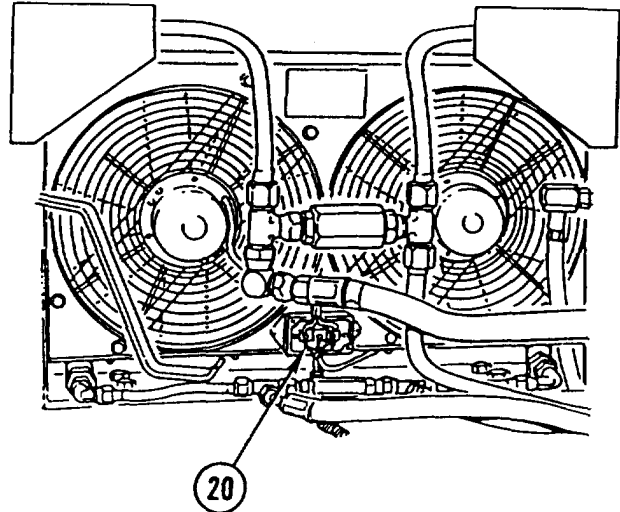

11. INSTALL COVER (21) and two screws (22).
12. POSITION control TOWER (23) and INSTALL five SCREWS (24).

NOTE

Follow-on Maintenance:
Check front and rear hydraulic tanks (TM 5-2420-224-10).

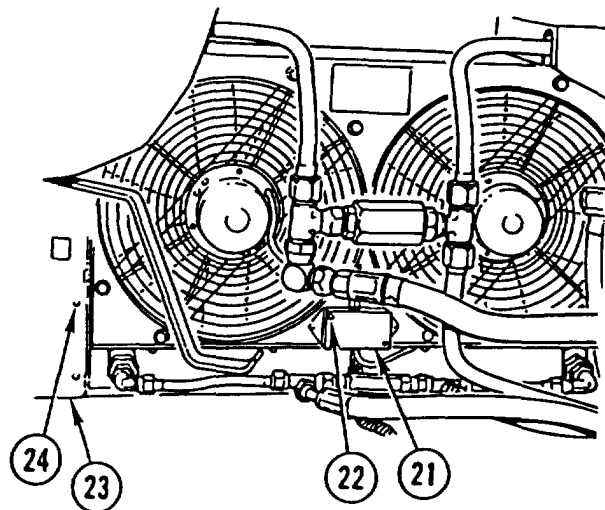

Section XVII. GAGES (NON-ELECTRICAL) MAINTENANCE

OVERVIEW

This section illustrates and describes procedures for maintenance of the gages (non-electrical) and related parts. A list of tasks contained in this section is shown below.

	Page
Speedometer Replacement	4-727
Speedometer Drive Shaft Replacement	4-730
Inclinometer Replacement and Adjustment	4-731
Counter Engine Revolution (Hourmeter) Replacement	4-733
STE/ICE-R Tachometer Drive and Cable Replacement	4-734

SPEEDOMETER REPLACEMENT

This task covers: a. Removal b. Installation

INITIAL SETUP

Tools and Special Equipment:

Tool Kit, SC 5180-90-CL-N26

Materials/Parts:

Packing
Seal, Wire

Equipment Condition:

Reference	Condition Description
Page 4-388	Outside Engine Hood Removed
Page 4-166	Fuse Holder Removed

REMOVAL

1. REMOVE and DISCARD wire SEAL (1) and DISCONNECT speedometer drive SHAFT (2).
2. REMOVE two nuts (3) and BRACKET (4).

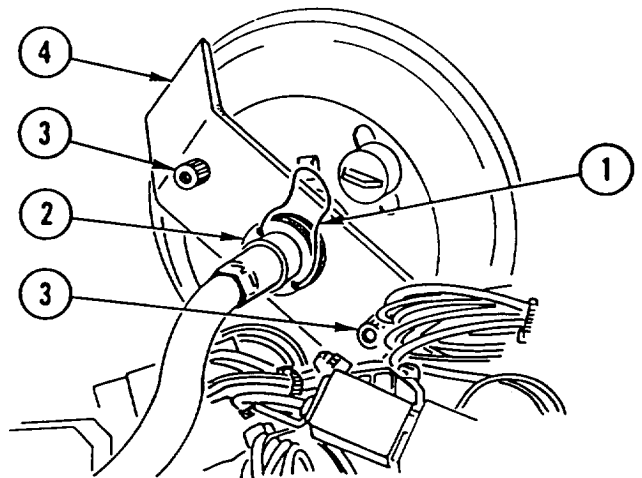

SPEEDOMETER REPLACEMENT (CONT)

3. REMOVE SPEEDOMETER (5) from dashboard (6).
4. DISCONNECT CONNECTOR (7) from speedometer (5).

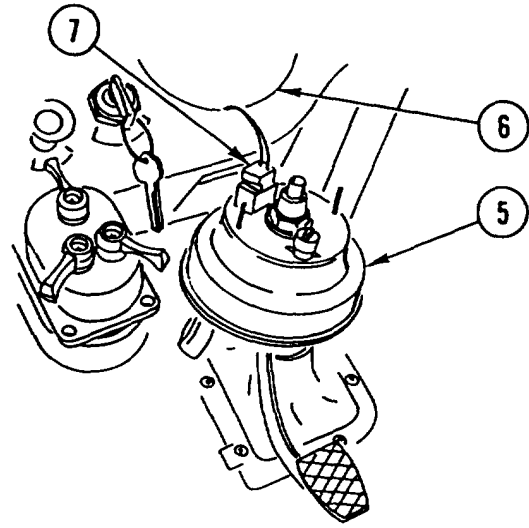

5. REMOVE and DISCARD PACKING (8) from speedometer (5).
6. REMOVE two lamp HOLDERS (9) from speedometer (5).

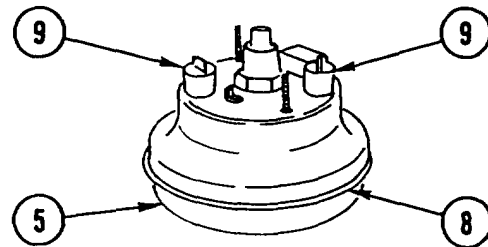

7. REMOVE light BULB (10) and FILTER (11) from each lamp holder (9).

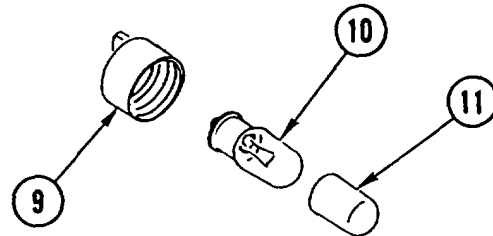

INSTALLATION

1. INSTALL light BULB (1) and FILTER (2) in each lamp holder (3).

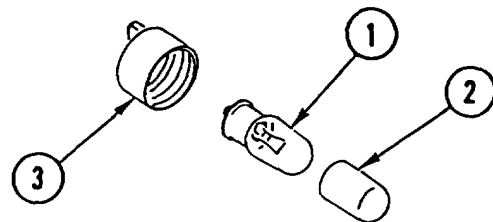

SPEEDOMETER REPLACEMENT (CONT)

2. INSTALL two lamp HOLDERS (3) in speedometer (4).
3. INSTALL new PACKING (5) on speedometer (4).

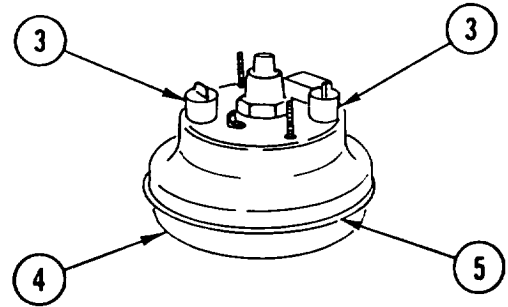

4. CONNECT CONNECTOR (6) to speedometer (4).
5. INSTALL SPEEDOMETER (4) in dashboard (7).

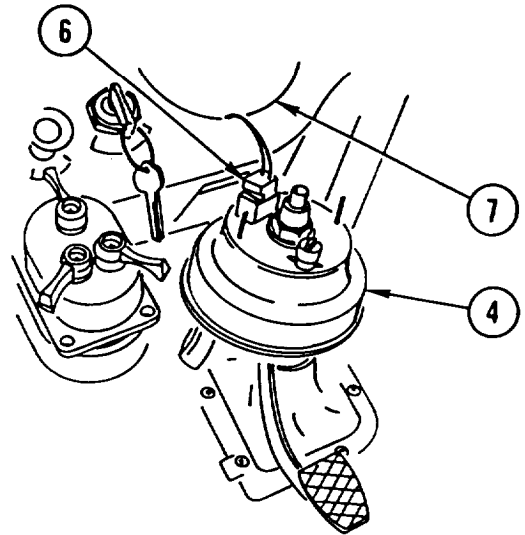

6. INSTALL BRACKET (8) and two nuts (9).
7. CONNECT speedometer drive SHAFT (10) and INSTALL new wire SEAL (11).

NOTE

Follow-on Maintenance:
 Install fuse holder (page 4-166).
 Install outside engine hood (page 4-388).

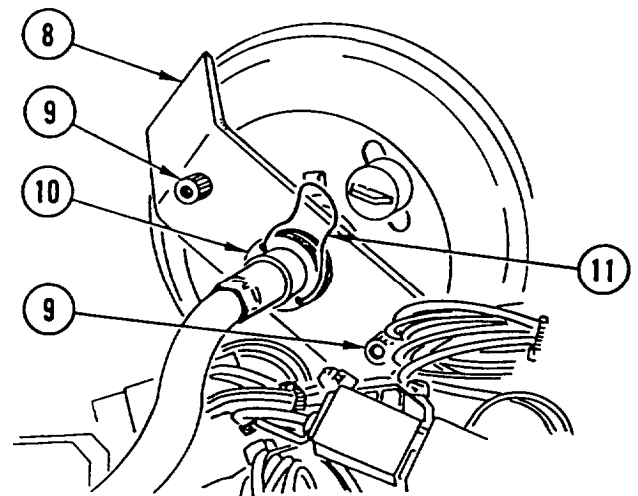

SPEEDOMETER DRIVE SHAFT REPLACEMENT

This task covers: a. Removal b. Installation

INITIAL SETUP

Tools and Special Equipment:

Tool Kit, SC 5180-90-CL-N26

Materials/Parts:

Seal, Wire

Equipment Condition:

Reference

Page 4-388

Page 4-166

Condition Description

Outside Engine Hood
Removed

Fuse Holder Removed

REMOVAL

1. REMOVE and DISCARD wire SEAL (1) and Disconnect speedometer drive SHAFT (2).
2. Disconnect speedometer drive SHAFT (2) from adapter (3) and REMOVE speedometer drive SHAFT (2).

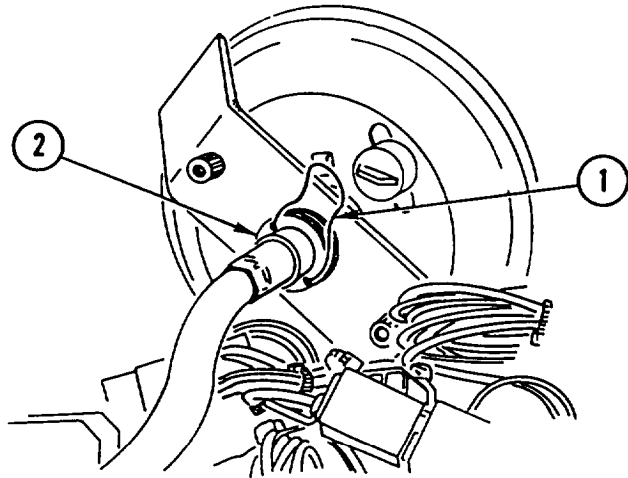

INSTALLATION

CAUTION

Make sure there are no kinks in cable. Failure to do so could result in damage to speedometer.

1. INSTALL speedometer drive SHAFT (2) and CONNECT to adapter (3).
2. CONNECT speedometer drive SHAFT (2) and INSTALL new wire SEAL (1).

NOTE

Follow-on Maintenance:
Install fuse holder (page 4-166).
Install outside engine hood (page 4-388).

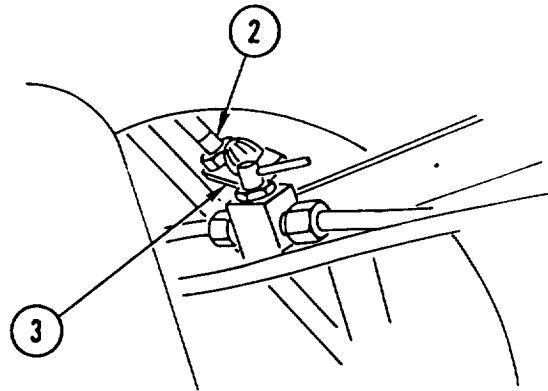

INCLINOMETER REPLACEMENT AND ADJUSTMENT

This task covers: a. Removal b. Installation c. Adjustment

INITIAL SETUP

Applicable Configuration:

SEE

Tools and Special Equipment:

Tool Kit, SC 5180-90-CL-N26

Materials/Parts:

Nut, Lock (2)

References:

TM 5-2420-224-10

Equipment Condition:

Reference

TM 5-2420-224-10

Condition Description

Front Loader and Backhoe in Travel Position and Vehicle Parked on Level Surface

REMOVAL

1. REMOVE two lock nuts (1), two screws (2), and INCLINOMETER (3). DISCARD lock NUTS.
2. REMOVE two self-tapping screws (4) and mounting BRACKET (5) from instrument panel (6).

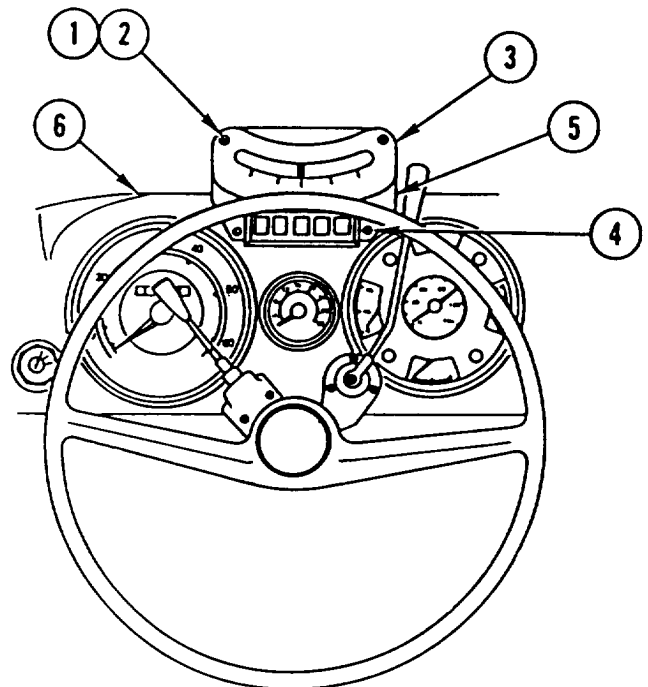

INSTALLATION

1. INSTALL mounting BRACKET (5) and two self-tapping screws (4) on instrument panel (6).

CAUTION

To avoid breaking inclinometer case, be careful not to overtighten lock nuts.

2. INSTALL INCLINOMETER (3), two screws (2), and two new lock nuts (1).

INCLINOMETER REPLACEMENT AND ADJUSTMENT (CONT)

ADJUSTMENT

WARNING

Before adjusting inclinometer, make sure vehicle is parked on level surface. Failure to do so will result in an inaccurate adjustment, which could result in serious personnel injury.

CAUTION

To avoid breaking inclinometer case, be careful not to overtighten lock nuts.

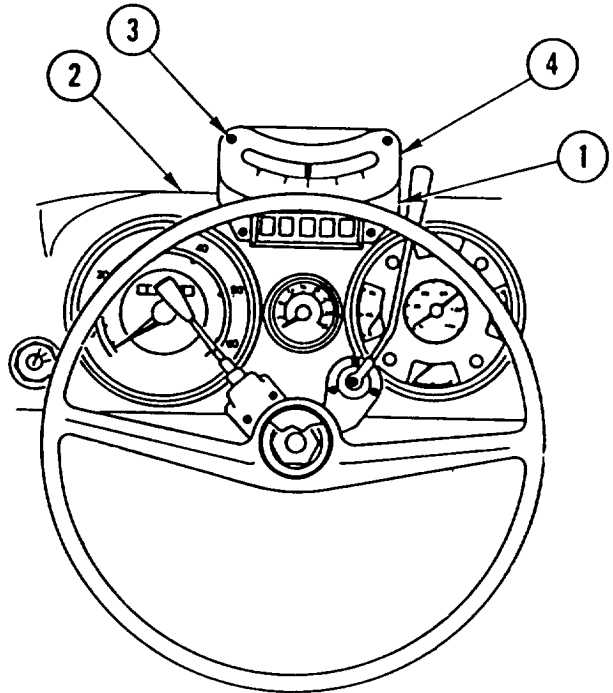

With mounting bracket (1) secured tightly to instrument panel (2), loosen two lock nuts (3) enough to move inclinometer (4). Adjust position of inclinometer until indicator indicates 0 on scale when viewed from operator's seat. Tighten two lock nuts (3), being careful not to move inclinometer. Check that indicator is still on 0. If not, repeat adjustment.

COUNTER ENGINE REVOLUTION (HOURMETER) REPLACEMENT

This task covers: a. Removal b. Installation

INITIAL SETUP

Tools and Special Equipment:

Tool Kit, SC 5180-90-CL-N26
Tool Set A, P/N 419 000 7458

Materials/Parts:

Washer, Lock (3)

Gasket

Equipment Condition:

Reference

Page 4-388

Condition Description

Outside Engine Hood
Removed

REMOVAL

REMOVE three screws (1), three lock washers (2), HOURMETER (3), and gasket (4). DISCARD lock WASHERS and GASKET.

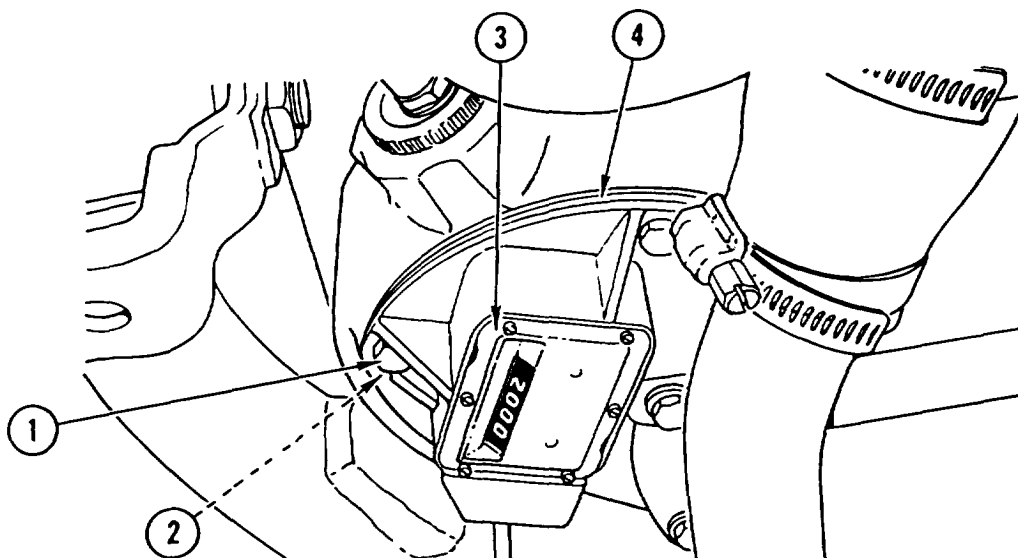

INSTALLATION

CAUTION

Make sure all gasket material has been removed from mating surfaces to prevent damage to equipment.

INSTALL new gasket (4), HOURMETER (3), three new lock washers (2), and three screws (1).

NOTE

Follow-on Maintenance:
Install outside engine hood (page 4-388).

STE/ICE-R TACHOMETER DRIVE AND CABLE REPLACEMENT

This task covers: a. Removal b. Installation

INITIAL SETUP

Tools and Special Equipment:

Shop Equipment SC 4910-95-CL-A74
 Tool Kit, SC 5180-90-CL-N26

Materials/Parts:

Washer, Lock

Equipment Condition:

Reference

Page 2-24
 Page 4-389

Condition Description

Batteries Disconnected
 Inside Engine Hood Removed

REMOVAL

1. DISCONNECT PLUG (1) from wiring harness (2).
2. REMOVE STE/ICE-R tachometer DRIVE (3) from tachometer drive cable (4).

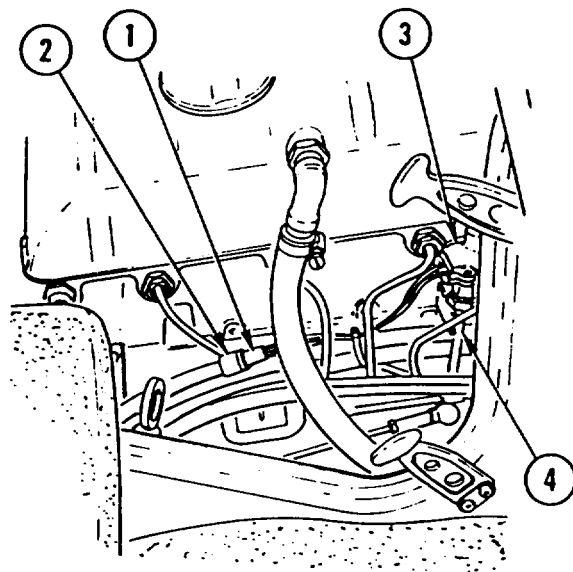

3. REMOVE nut (5), washer (6), bolt (7), and CLAMP (8) from tachometer drive cable (4) and bracket (9).
4. REMOVE tachometer drive CABLE (4) from engine block (10).
5. REMOVE bolt (11), lock washer (12), and BRACKET (9) from engine block (10). DISCARD lock WASHER.

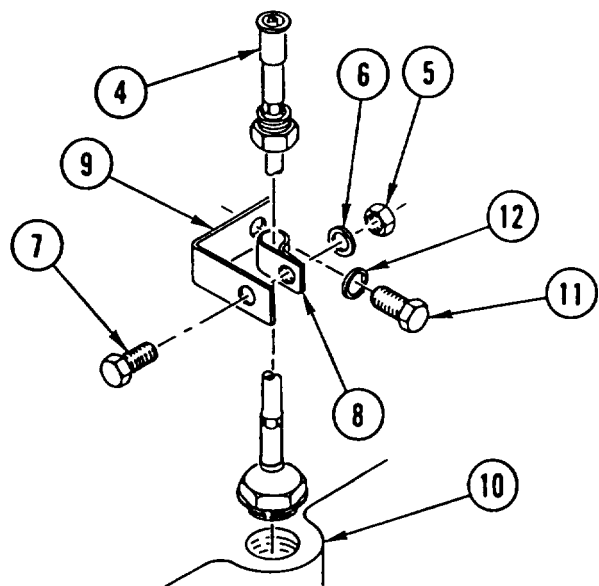

STE/ICE-R TACHOMETER DRIVE AND CABLE REPLACEMENT (CONT)

INSTALLATION

1. INSTALL BRACKET (1), new lock washer (2), and bolt (3) in engine block (4).
2. INSTALL tachometer drive CABLE (5) in engine block (4).
3. INSTALL CLAMP (6) on tachometer drive cable (5).
4. INSTALL BOLT (7), washer (8), and nut (9) through bracket (1) and clamp (6).

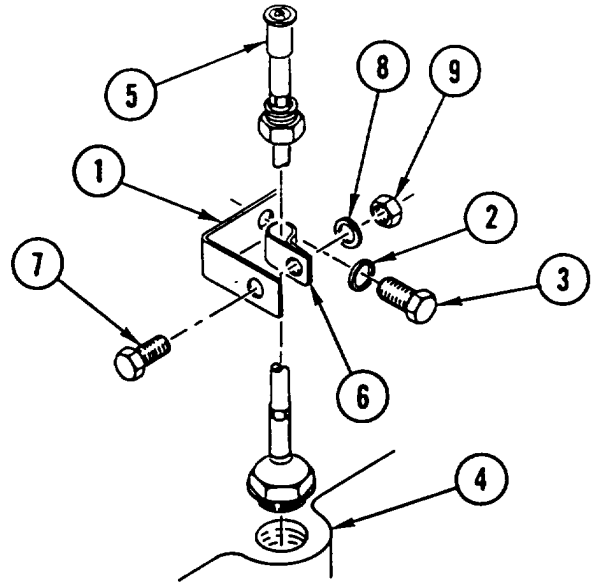

5. INSTALL STE/ICE-R tachometer DRIVE (10) on tachometer drive cable (5).
6. CONNECT PLUG (11) to wiring harness (12).

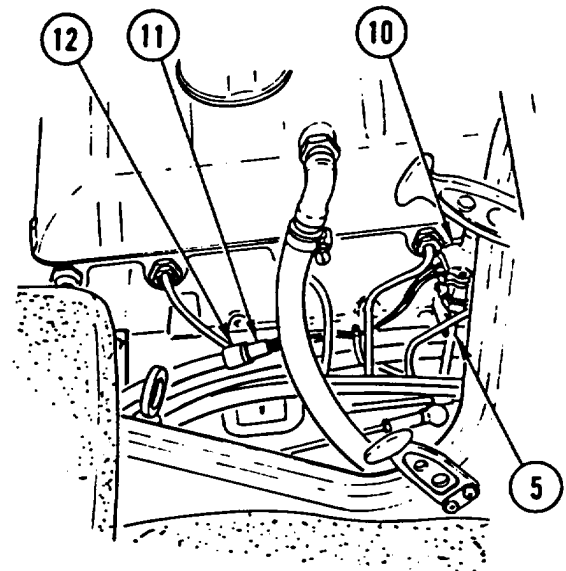

NOTE

Follow-on Maintenance:
 Install inside engine hood (page 4-389).
 Connect batteries (page 2-24).

Section XVIII. MACHINE TOOLS AND RELATED EQUIPMENT MAINTENANCE

OVERVIEW

This section illustrates and describes procedures for maintenance of the machine (hydraulic) tools and related parts. A list of tasks contained in this section is shown below.

	Page
Hammer Drill Hoses Replacement	4-736
Impact Wrench Hoses Replacement	4-738
Pavement Breaker Hoses Replacement	4-740
Chain Saw Hoses Replacement	4-742
Chain Saw Chain and Bar Replacement	4-744
Chain Saw Trigger, Guard, and Handle Bar Replacement	4-746

HAMMER DRILL HOSES REPLACEMENT

This task covers: a. Removal b. Installation

INITIAL SETUP

Applicable Configuration:

SEE

Tools and Special Equipment:

Shop Equipment, SC 4910-95-CL-A74
Tool Kit, SC 5180-90-CL-N26

Materials/Parts:

- Packing (4)
- Oil, Lubricating Appendix C, item 22
- Rags Appendix C, item 32

Equipment Condition:

Reference	Condition Description
	Hammer Drill on Workbench

General Safety Instructions:

WARNING

Fuel and oil are slippery and can cause falls. To avoid injury, wipe up spilled fuel or oil with rags.

HAMMER DRILL HOSES REPLACEMENT (CONT)

REMOVAL

1. REMOVE female COUPLING HALF (1) and packing (2) from hose assembly (3). DISCARD PACKING.

NOTE

Tag all lines prior to removal to aid in installation.

2. REMOVE HOSE assembly (3) and packing (4) from housing (5). DISCARD PACKING.
3. REMOVE male COUPLING HALF (6) and packing (7) from hose assembly (8). DISCARD PACKING.
4. REMOVE HOSE assembly (8) and packing (9) from housing (5). DISCARD PACKING.

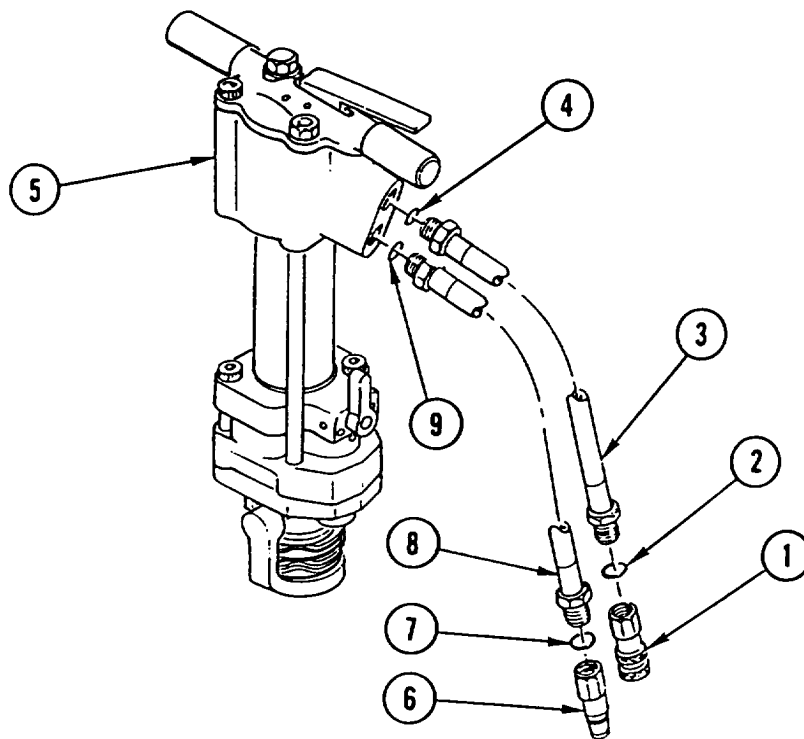

INSTALLATION

NOTE

Apply coat of lubricating oil to packings prior to installation.

1. INSTALL new packing (9) and HOSE assembly (8) in housing (5).
2. INSTALL new packing (7) and male COUPLING HALF (6) on hose assembly (8).
3. INSTALL new packing (4) and HOSE assembly (3) in housing (5).
4. INSTALL new packing (2) and female COUPLING HALF (1) on hose assembly (3).

IMPACT WRENCH HOSES REPLACEMENT

This task covers: a. Removal b. Installation

INITIAL SETUP

Applicable Configuration:

HMMH

Equipment Condition:

Reference

Condition Description

Tools and Special Equipment:

Shop Equipment, SC 4910-95-CL-A74
Tool Kit, SC 5180-90-CL-N26

Impact Wrench on
Workbench

General Safety Instructions:

Materials/Parts:

Packing (4)

Oil, Lubricating

Appendix C, Item 22

Rags

Appendix C, Item 32

WARNING

Fuel and oil are slippery and can cause falls. To avoid injury, wipe up spilled fuel or oil with rags.

REMOVAL

1. REMOVE female COUPLING HALF (1) and packing (2) from hose assembly (3), DISCARD PACKING.

NOTE

Tag all lines prior to removal to aid in installation.

2. REMOVE HOSE assembly (3) and packing (4) from housing (5). DISCARD PACKING.
3. REMOVE male COUPLING HALF (6) and packing (7) from hose assembly (8). DISCARD PACKING.
4. REMOVE HOSE assembly (8) and packing (9) from housing (5). DISCARD PACKING.

IMPACT WRENCH HOSES REPLACEMENT (CONT)

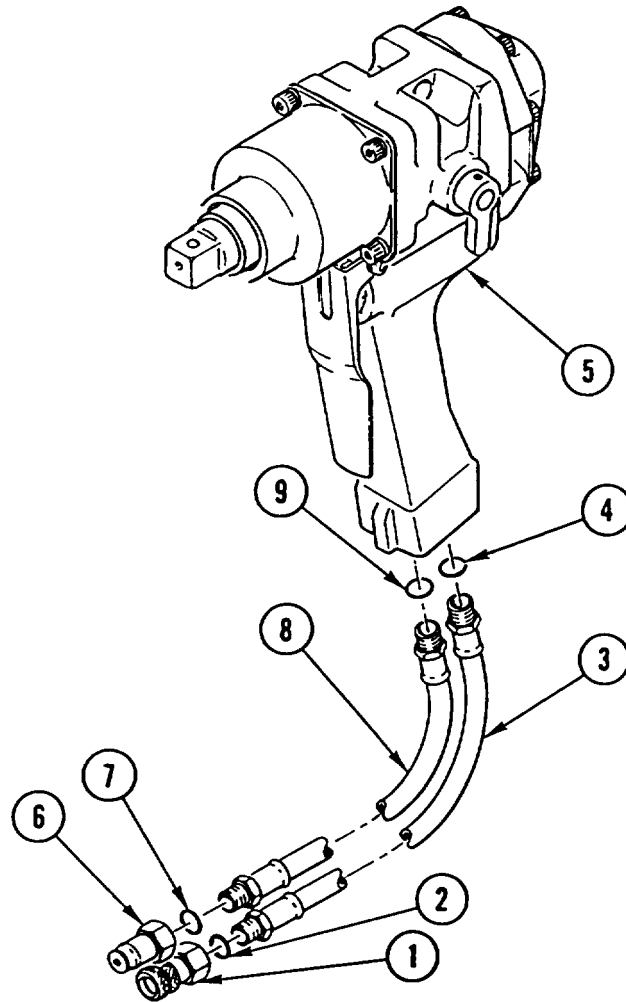
**INSTALLATION****NOTE**

Apply coat of lubricating oil to packings prior to installation.

1. INSTALL HOSE assembly (8) and new packing (9) in housing (5).
2. INSTALL male COUPLING HALF (6) and new packing (7) on hose assembly (8).
3. INSTALL HOSE assembly (3) and new packing (4) in housing (5).
4. INSTALL female COUPLING HALF (1) and new packing (2) on hose assembly (3).

PAVEMENT BREAKER HOSES REPLACEMENT

This task covers: a. Removal b. Installation

INITIAL SETUP

Applicable Configuration:

SEE

Equipment Condition:

Reference

Condition Description

Tools and Special Equipment:

Shop Equipment, SC 4910-95-CL-A74
Tool Kit, SC 5180-90-CL-N26

Pavement Breaker on
Workbench

General Safety Instructions:

Materials/Parts:

Packing (4)

Oil, Lubricating Appendix C, Item 22

Rags Appendix C, item 32

W A R N I N G

Fuel and oil are slippery and
can cause falls. To avoid
injury, wipe up spilled fuel or
oil with rags.

REMOVAL

1. REMOVE female COUPLING HALF (1) and packing (2) from hose assembly (3). DISCARD PACKING.

NOTE

Tag ail lines prior to removal to aid in installation.

2. REMOVE HOSE assembly (3) and packing (4) from handle (5). DISCARD PACKING.
3. REMOVE male COUPLING HALF (6) and packing (7) from hose assembly (8). DISCARD PACKING.
4. REMOVE HOSE assembly (8) and packing (9) from handle (5). DISCARD PACKING.

PAVEMENT BREAKER HOSES REPLACEMENT (CONT)

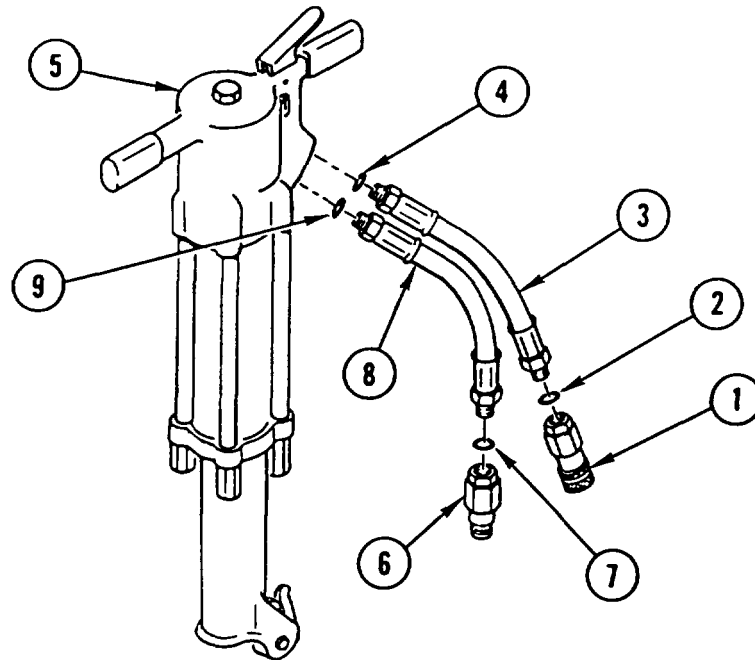
**INSTALLATION****NOTE**

Apply coat of lubricating oil to packings prior to installation.

1. INSTALL new packing (9) and HOSE assembly (8) on handle (5).
2. INSTALL new packing (7) and male COUPLING HALF (6) on hose assembly (8).
3. INSTALL new packing (4) and HOSE assembly (3) on handle (5).
4. INSTALL new packing (2) and female COUPLING HALF (1) on hose assembly (3).

CHAIN SAW HOSES REPLACEMENT

This task covers: a. Removal b. Installation

INITIAL SETUP

Applicable Configuration:

SEE

Equipment Condition:

Reference

Condition Description

Tools and Special Equipment:

Shop Equipment, SC 4910-95-CL-A74
Tool Kit, SC 5180-90-CL-N26

Chain Saw on
Workbench

General Safety Instructions:

Materials/Parts:

Packing (4)

Oil, Lubricating Appendix C, Item 22

Rags Appendix C, Item 32

W A R N I N G

Fuel and oil are slippery and can cause falls. To avoid injury, wipe up spilled fuel or oil with rags.

REMOVAL

1. REMOVE female COUPLING HALF (1) and packing (2) from hose assembly (3). DISCARD PACKING.

NOTE

Tag all lines prior to removal to aid in installation.

2. REMOVE HOSE assembly (3) and packing (4) from handle assembly (5). DISCARD PACKING.
3. REMOVE male COUPLING HALF (6) and packing (7) from hose assembly (8). DISCARD PACKING.
4. REMOVE HOSE assembly (8) and packing (9) from handle assembly (5). DISCARD PACKING.

CHAIN SAW HOSES REPLACEMENT (CONT)

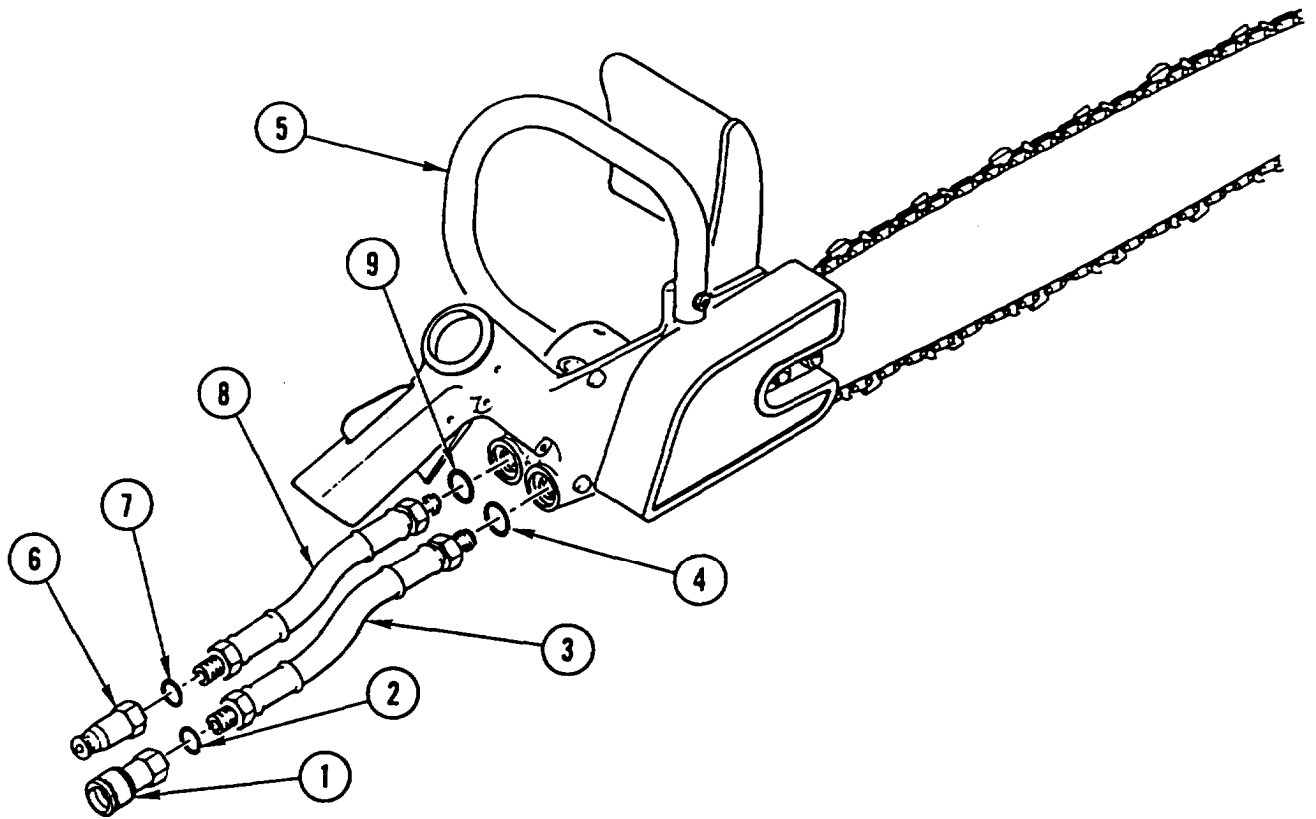

INSTALLATION

NOTE

Apply coat of lubricating oil to packings prior to installation.

1. INSTALL HOSE assembly (8) and new packing (9) on handle assembly (5).
2. INSTALL HOSE assembly (3) and new packing (4) on handle assembly (5).

NOTE

Install male coupling half on hose assembly from out port of handle assembly.

3. INSTALL male COUPLING HALF (6) and new packing (7) on hose assembly (8).
4. INSTALL female COUPLING HALF (1) and new packing (2) on hose assembly (3).

CHAIN SAW CHAIN AND BAR REPLACEMENT

This task covers: a. Removal b. Installation

INITIAL SETUP

Applicable Configuration:

SEE

Tools and Special Equipment:

Tool Kit, SC 5180-90-CL-N26

Materials/Parts:

Oil, Lubricating Appendix C, Item 22

References:

TM 5-2420-224-10

General Safety Instructions:

WARNING

Never inspect, clean, or replace chain or bar with operating pressure at tool. To do so could result in injury to personnel.

Chain cutters are sharp. Wear protective gloves when removing, installing, or adjusting chain. Failure to do so could result in injury to personnel.

REMOVAL

1. REMOVE two nuts (1), two washers (2), GUARD (3), and GUARD (4) from handle assembly (5).
2. TURN SCREW (6) COUNTERCLOCKWISE until chain (7) has enough slack to clear sprocket (8).
3. REMOVE GUARD (9), BAR (10), and CHAIN (7) as an assembly and REMOVE GUARD (11) from handle assembly (5).
4. REMOVE assembled CHAIN and BAR from guard (9).
5. REMOVE CHAIN (7) from bar (10).

INSTALLATION

1. APPLY COAT of LUBRICATING OIL to CHAIN and INSTALL CHAIN (7) on bar (10).
2. INSTALL GUARD (11) on handle assembly (5).
3. INSTALL BAR (10) and CHAIN (7) as an assembly on handle assembly (5).
4. PLACE CHAIN (7) on sprocket (8).
5. SLIDE BAR (10) FORWARD, away from handle assembly (5).
6. INSTALL GUARD (4), GUARD (3), two washers (2), and two nuts (1) on handle assembly (5).
7. TURN SCREW (6) CLOCKWISE until chain (7) is snug to bar (10).
8. INSTALL GUARD (9).

CHAIN SAW CHAIN AND BAR REPLACEMENT (CONT)

NOTE

Follow-on Maintenance:
Adjust chain tension (TM 5-2420-224-10).

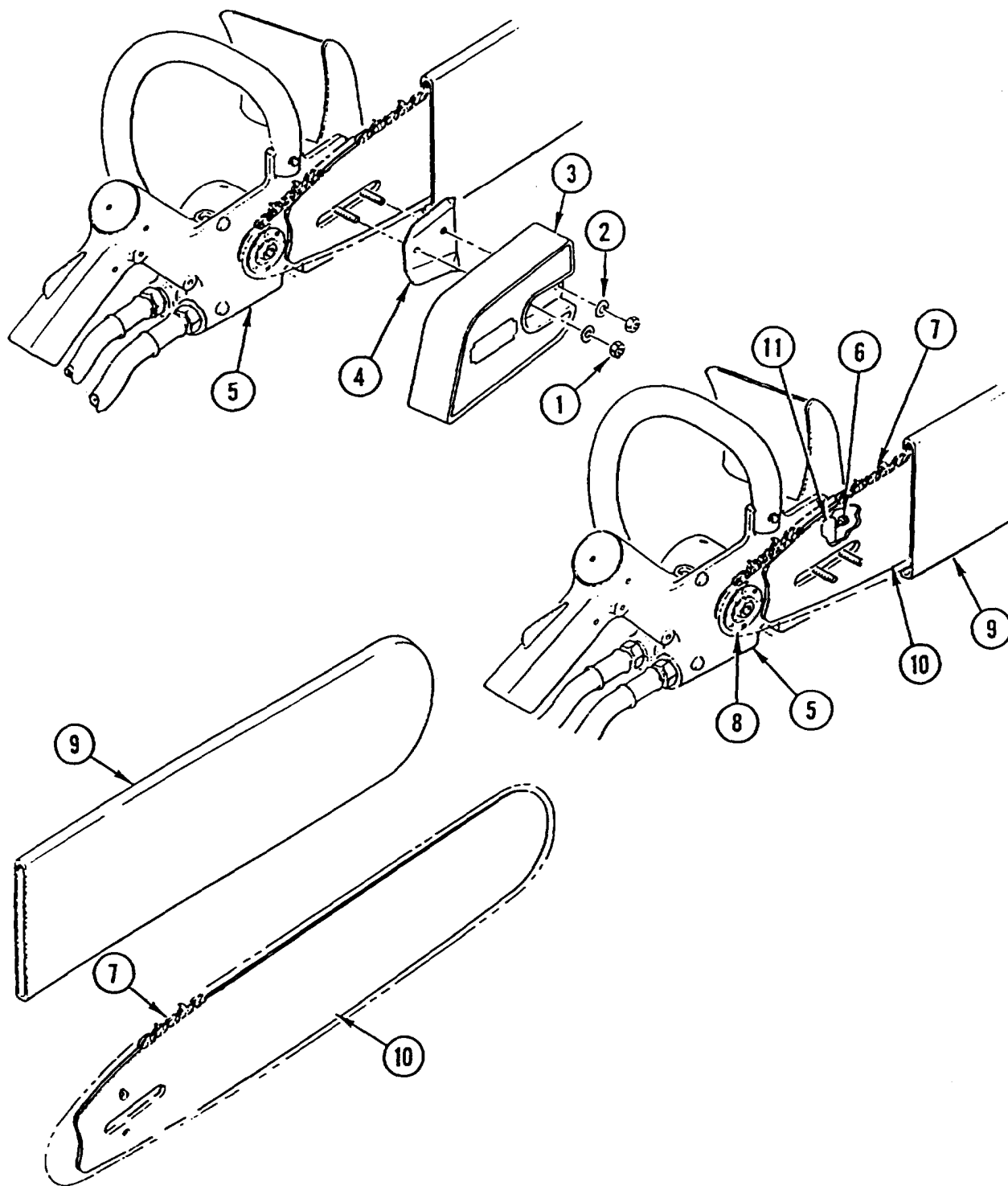

CHAIN SAW TRIGGER, GUARD, AND HANDLE BAR REPLACEMENT

This task covers: a. Removal b. Installation

INITIAL SETUP

Applicable Configuration:

SEE

Tools and Special Equipment:

Tool Kit, SC 5180-90-CL-N26

Materials/Parts:

Nut, Lock

Packing

Oil, Lubricating Appendix C, Item 22

References:

TM 5-2420-224-10

Equipment Condition:

Reference

Page 4-742

Page 4-744

Condition Description

Chain Saw Hoses
Removed

Chain Saw Chain and
Bar Removed

REMOVAL

1. REMOVE PLUG (1).
2. REMOVE spring PIN (2).
3. DEPRESS safety CATCH (3) and REMOVE TRIGGER (4) through bottom of handle assembly (5).
4. REMOVE spring PIN (6), safety CATCH (3), and spring (7).
5. IF WORN OR DAMAGED, REMOVE PIN (8) from safety catch (3).

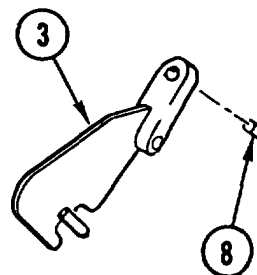
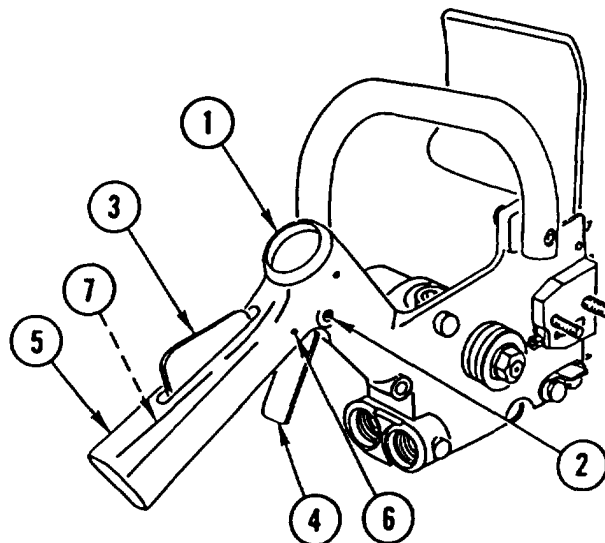

CHAIN SAW TRIGGER, GUARD, AND HANDLE BAR REPLACEMENT (CONT)

6. REMOVE lock nut (9), SCREW (10), and adjustment nut (11). DISCARD lock NUT.

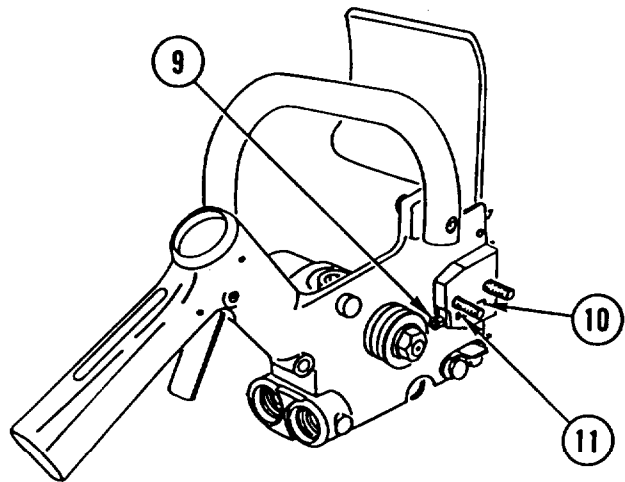

7. REMOVE screw (12), nut (13), screw (14), and CATCHER (15).

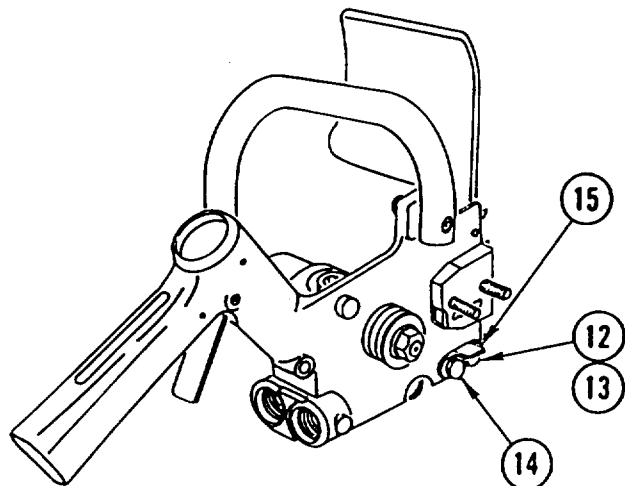

8. REMOVE screw (16), washer (17), screw (18), nut (19), washer (20), GUARD (21), and CLEAT (22).

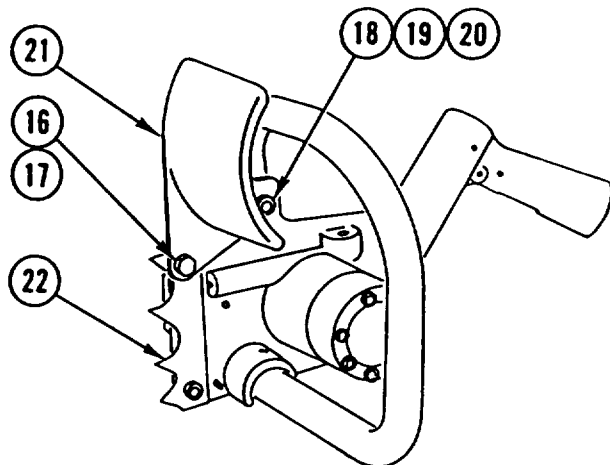

CHAIN SAW TRIGGER, GUARD, AND HANDLE BAR REPLACEMENT (CONT)

9. REMOVE two screws (23) and handle BAR (24) from handle assembly (5).
10. REMOVE two RETAINERS (25 and 26) from handle bar (24).

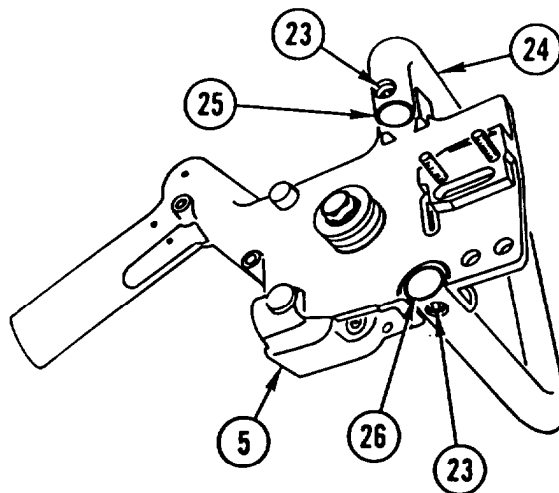

11. REMOVE PLUG (27) and packing (28). DISCARD PACKING.

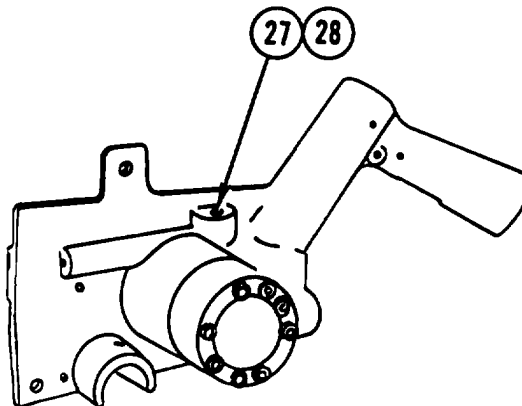

INSTALLATION

1. APPLY COAT of LUBRICATING OIL to new packing (1).
2. INSTALL PLUG (2) and packing (1) in handle assembly (3) until slight resistance is felt. BACK OUT PLUG (2) 1/2 to 1 turn.

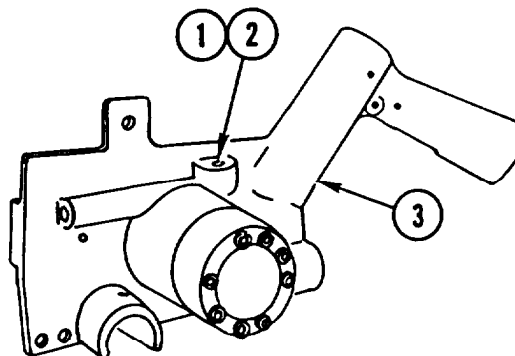

CHAIN SAW TRIGGER, GUARD, AND HANDLE BAR REPLACEMENT (CONT)

3. INSTALL two RETAINERS (4 and 5) in handle bar (6).
4. INSTALL handle BAR (6) and two screws (7) on handle assembly (3).

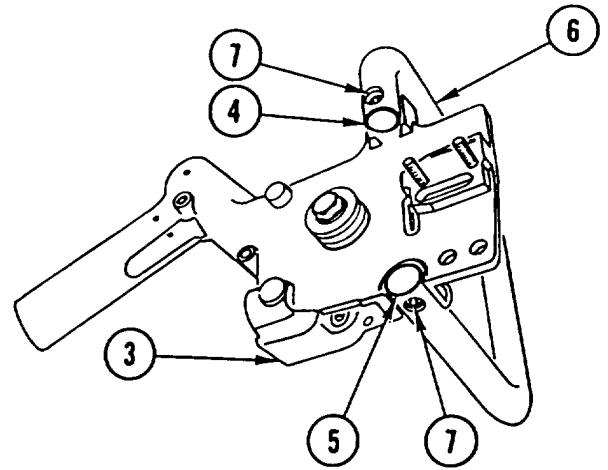

5. INSTALL CLEAT (8), GUARD (9), screw (10), washer (11), screw (12), nut (13), and washer (14).

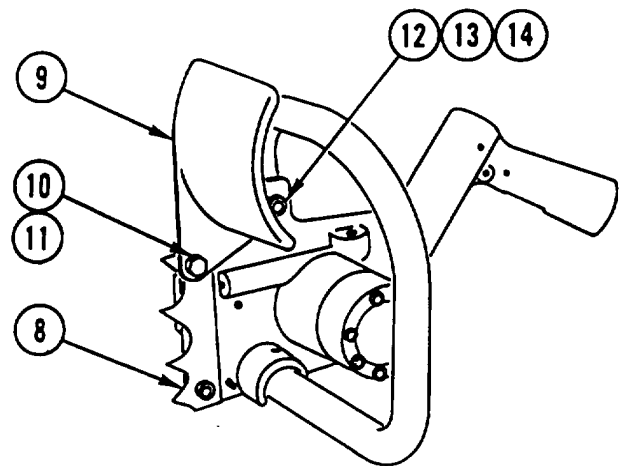

6. INSTALL CATCHER (15), screw (16), nut (17), and screw (18).

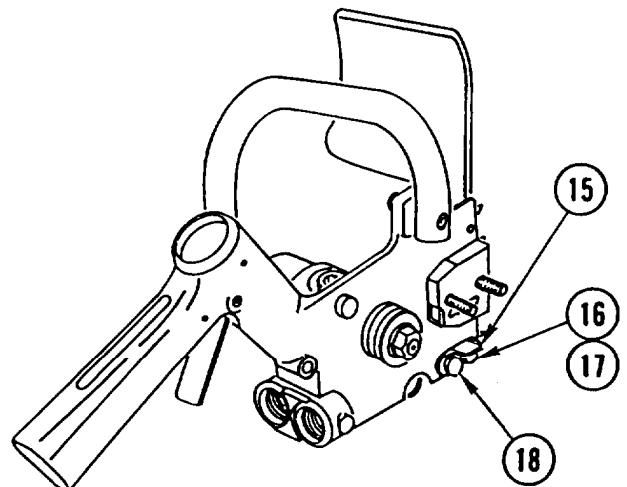

CHAIN SAW TRIGGER, GUARD, AND HANDLE BAR REPLACEMENT (CONT)

7. INSTALL SCREW (19), adjustment nut (20), and new lock nut (21).

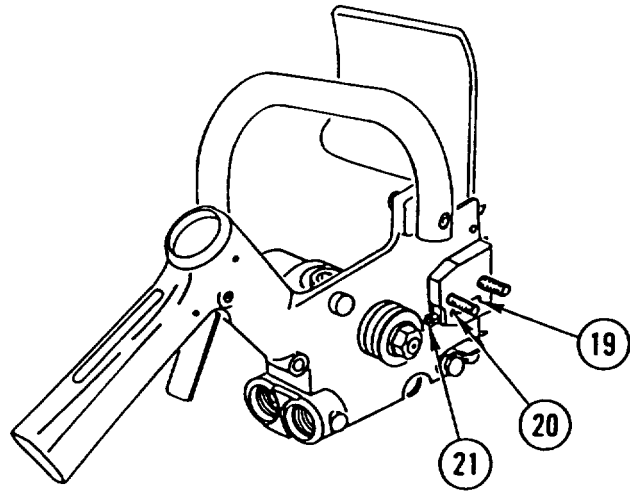

8. IF REMOVED, INSTALL new PIN (22) in safety catch (23).

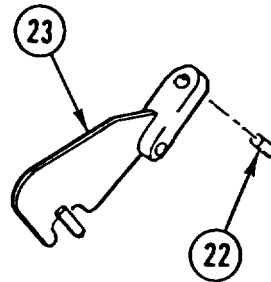

NOTE

Make sure spring is installed in recess of handle assembly.

9. INSTALL safety CATCH (23), spring (24), and spring PIN (25) in handle assembly (3).
10. DEPRESS safety CATCH (23) and INSTALL TRIGGER (26) through bottom of handle assembly (3).
11. INSTALL spring PIN (27) and PLUG (28).

NOTE

Follow-on Maintenance:

Install chain saw hoses (page 4-742).
 Install chain saw chain and bar (page 4-744).
 Adjust chain tension (TM 5-2420-224-10).
 Adjust chain saw oiler (TM 5-2420-224-10).

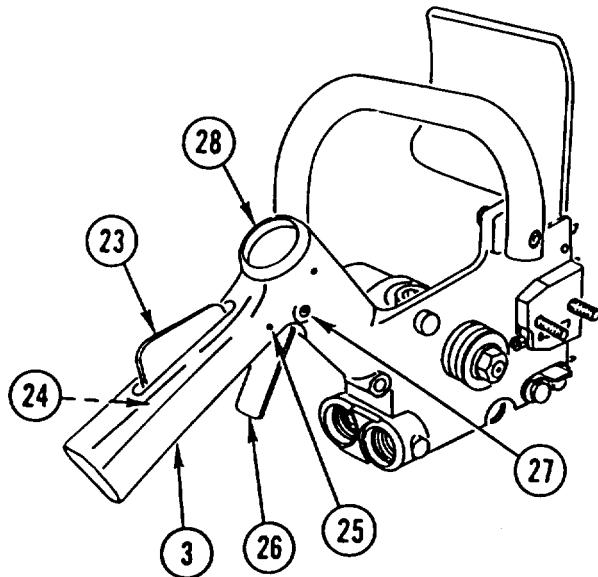

Section XIX. CRANES, SHOVELS, AND EARTHMOVING EQUIPMENT COMPONENTS MAINTENANCE

OVERVIEW

This section illustrates and describes procedures for maintenance of the cranes, shovels, and earthmoving equipment components and related parts. A list of tasks contained in this section is shown below.

	Page
Backhoe Boom Replacement	4-752
Backhoe Assembly Replacement	4-754
Backhoe Dipper Replacement and Repair...	4-760
Backhoe Bucket Replacement	4-762
Backhoe Bucket (Ripper) Bearings Replacement	4-763
Backhoe Bucket Links Replacement	4-764
Backhoe Bucket/Ripper Tooth Replacement.. . . .	4-766
Backhoe Boom Latch Release Lever Replacement	4-768
Backhoe Boom Latch Replacement	4-770
Backhoe Swing Tower Replacement	4-772
Backhoe Stabilizer Replacement	4-774
Crane Replacement	4-776
Crane Hook Assembly Replacement	4-783
Crane Rear Outrigger Replacement	4-784
Crane Travel Lock Replacement and Adjustment	4-786
Crane Rotation Lock Replacement and Adjustment	4-790
Front Loader Replacement	4-794
Front Loader Main Frame Replacement	4-800
Front Loader Bucket Replacement	4-802
Front Loader Bucket Tooth Replacement	4-804
Front Loader Lift Arm Replacement	4-805

BACKHOE BOOM REPLACEMENT

This task covers: a. Removal b. Installation

INITIAL SETUP

Applicable Configuration:

SEE

Tools and Special Equipment:

Shop Equipment, SC 4910-95-CL-A74
Tool Kit, SC 5180-90-CL-N26

Materials/Parts:

Oil, Lubricating Appendix C, Item 22

Personnel Required: (3)

Equipment Condition:

Reference

Page 4-670

Page 4-760

Page 4-658

Page 4-610

Condition Description

Backhoe Dipper Cylinder
Removed

Backhoe Dipper Removed

Backhoe Boom Cylinders
Removed

Backhoe Boom Cylinder
Hydraulic Lines and
Fittings Removed

General Safety Instructions:

WARNING

Backhoe boom weighs 383 pounds (174 kilograms). To avoid personal injury, use a hoist or suitable lifting device when lifting backhoe boom.

REMOVAL

1. REMOVE two screws (1), two washers (2), two edge washers (3), two PINS (4), and BOOM (5).
2. IF DAMAGED, REMOVE two lubrication FITTINGS (6) from two pins (4).
3. REMOVE screw (7), MOUNT (8), support (9), shim(s) (10), spacer (11), and bar (12).
4. REMOVE BACKHOE BOOM LATCH (13) (page 4-770).
5. USING BRASS DRIFT PIN, REMOVE eight BUSHINGS (14, 15, 16, and 17).
6. IF DAMAGED, REMOVE three lubrication FITTINGS (18, 19, and 20).

BACKHOE BOOM REPLACEMENT (CONT)

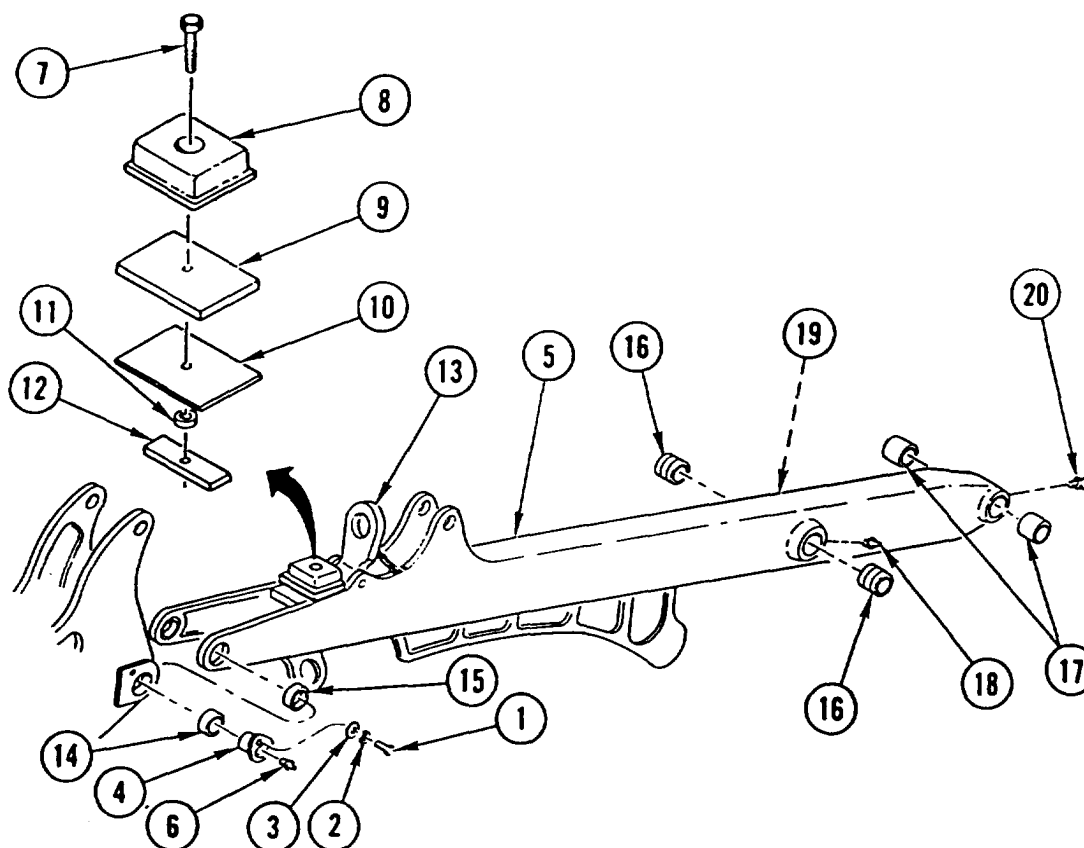

INSTALLATION

1. IF REMOVED, INSTALL three new lubrication FITTINGS (20, 19, and 18).
2. APPLY light COAT of LUBRICATING OIL to eight BUSHINGS and INSTALL eight BUSHINGS (14, 15, 16, and 17).
3. INSTALL BACKHOE BOOM LATCH (13) (page 4-770).
5. INSTALL bar (12), spacer (11), shim(s) (10), support (9), MOUNT (8), and screw (7).
6. IF REMOVED, INSTALL two new lubrication FITTINGS (6) in two pins (4).
7. INSTALL boom (5), two pins (4), two edge washers (3), two washers (2), and two SCREWS (1).

NOTE

Follow-on Maintenance:

- Install backhoe boom cylinder hydraulic lines and fittings (page 4-610).
- Install backhoe dipper (page 4-760).
- Install backhoe boom cylinders (page 4-658).
- Install backhoe dipper cylinder (page 4-670).

BACKHOE ASSEMBLY REPLACEMENT

This task covers: a. Removal b. Installation

INITIAL SETUP

Applicable Configuration:

SEE

Tools and Special Equipment:

Tool Kit, SC 5180-90-CL-N26

Materials/Parts:

Rags Appendix C, Item 32

Personnel Required: (2)

References:

TM 5-2420-224-10

Equipment Condition:

Reference	Condition Description
Page 2-22	Backhoe in Three-Point Stance
TM 5-2420-224-10	PTO Engaged
Page 4-186	Work Light Removed
Page 4-190	Rear Composite Stoplight/Taillight Removed
Page 4-362	Backhoe Subframe Deck Removed

General Safety Instructions:

WARNING

- High pressure hydraulics [oil under 2450 psi (16,893 kPa)] operate this equipment. Never disconnect any hydraulic line or fitting without first dropping pressure to zero. A high pressure oil stream can pierce body and cause severe injury to personnel.
- Fuel and oil are slippery and can cause falls. To avoid injury, wipe up spilled fuel or oil with rags.
- Do not connect or disconnect any electrical connector unless vehicle MASTER disconnect switch is OFF. To do so could result in injury to personnel.

REMOVAL

NOTE

Tag wires prior to removal to aid in installation.

1. CAREFULLY ROLL BACK rubber BOOTS and REMOVE two nuts (1) and two WIRES (2).
2. REMOVE four screws (3) and BOX (4).

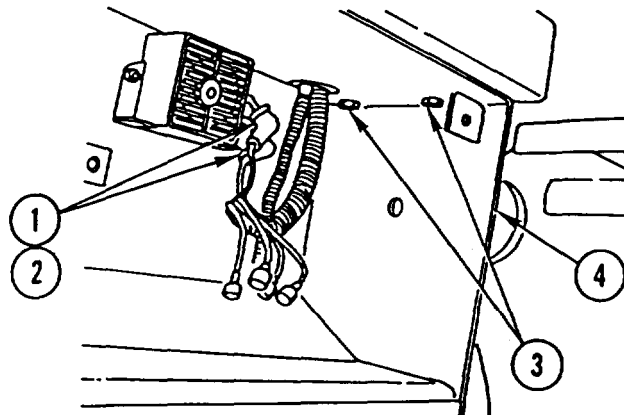

BACKHOE ASSEMBLY REPLACEMENT (CONT)

WARNING

Vehicle may move when backhoe mounting pins are removed resulting in possible injury to personnel.

NOTE

Stabilizers may be used to relieve pressure on mounting pins.

3. REMOVE four snap rings (5) and two mounting PINS (6).

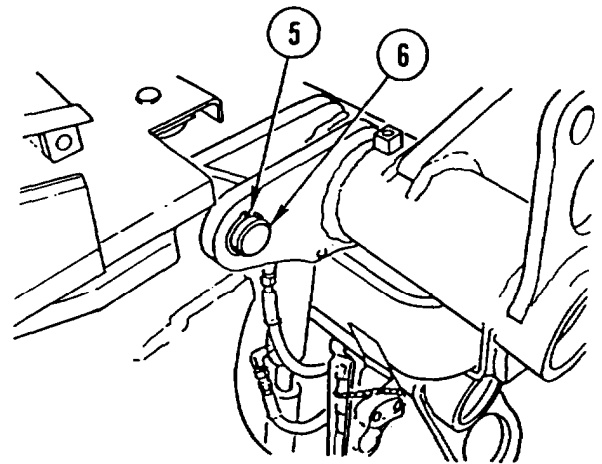

WARNING

Support tilt cylinder. Failure to do so could result in injury to personnel.

4. DISCONNECT tilt CYLINDER (7) by REMOVING two snap rings (8) and PIN (9).
5. START ENGINE. RETRACT tilt CYLINDER (7) from mounting eye and DISENGAGE backhoe lock CYLINDERS.

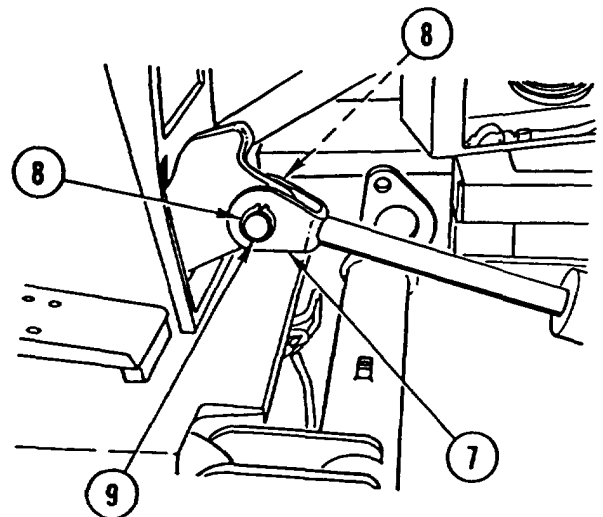

6. PULL TRACTOR FORWARD 6 to 10 in. and SHUT OFF ENGINE.

NOTE

Tag all lines prior to disconnecting to aid in connecting.

7. RELIEVE HYDRAULIC PRESSURE (page 2-23) and DISCONNECT hydraulic HOSE (10).

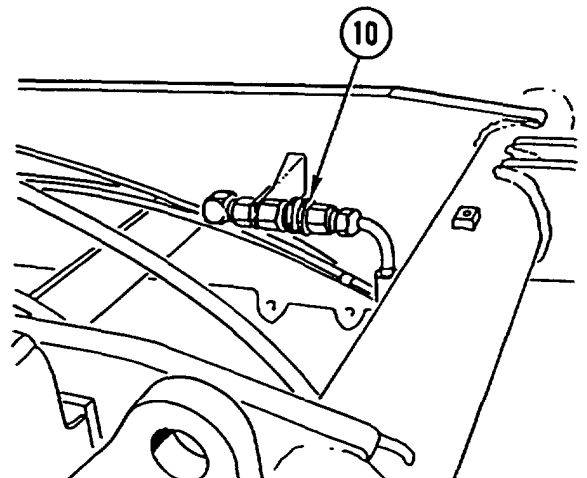

BACKHOE ASSEMBLY REPLACEMENT (CONT)

8. DISCONNECT hydraulic HOSE (11).

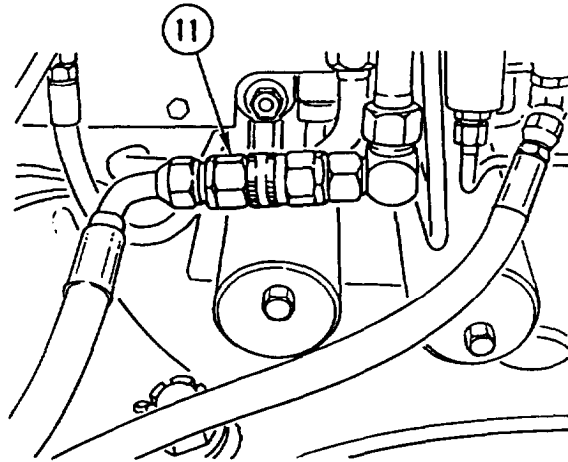

9. COUPLE tractor COUPLERS (12) together to complete hydraulic circuit.

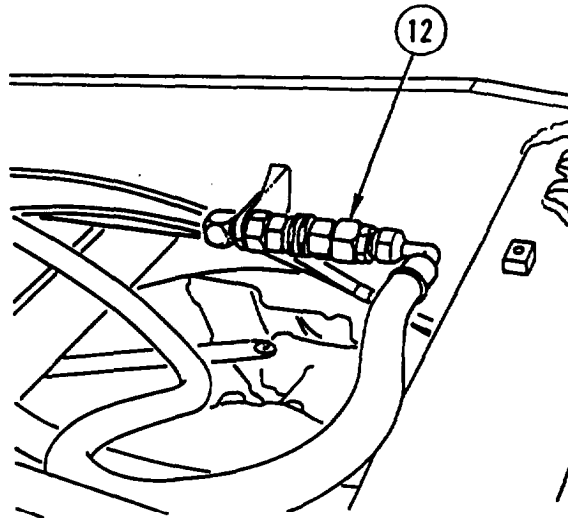

10. COUPLE backhoe CONNECTORS (13) together.

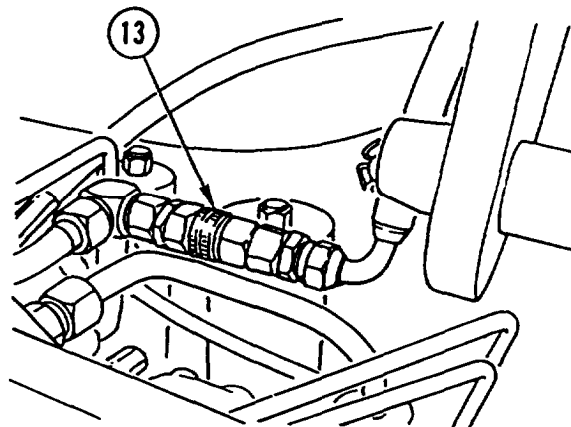

BACKHOE ASSEMBLY REPLACEMENT (CONT)

11. INSTALL BOX (4) and four screws (3)
12. INSTALL two WIRES (2) and two nuts (1) and CAREFULLY ROLL rubber BOOTS OVER connection.
13. INSTALL WORK LIGHT (page 4-186).
14. INSTALL REAR COMPOSITE STOPLIGHT/ TAILLIGHT (page 4-190).
15. DISENGAGE PTO (TM 5-2420-224-10).
16. SLOWLY MOVE VEHICLE AWAY from backhoe assembly.

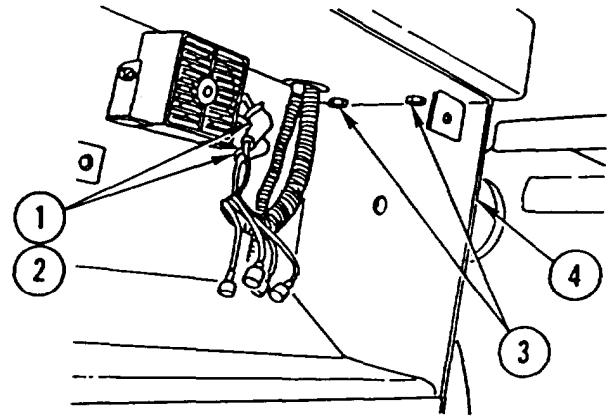

INSTALLATION

1. REMOVE WORK LIGHT (page 4-186).
2. REMOVE REAR COMPOSITE STOPLIGHT/ TAILLIGHT (page 4-190).

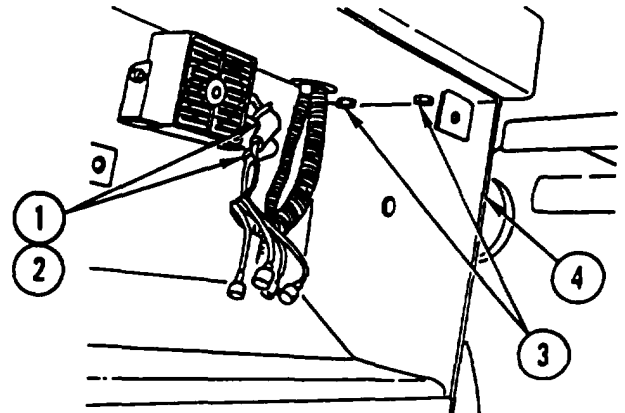

NOTE

Tag wires prior to removal to aid in installation.

3. CAREFULLY ROLL BACK rubber BOOTS and REMOVE two nuts (1) and two WIRES (2).
4. REMOVE four screws (3) and BOX (4).

5. DISCONNECT backhoe CONNECTORS (5).

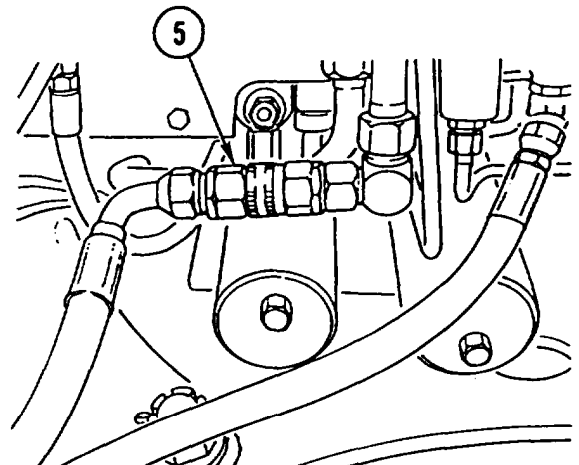

BACKHOE ASSEMBLY REPLACEMENT (CONT)

WARNING

Support tilt cylinder. Failure to do so could result in injury to personnel.

6. DISCONNECT tractor COUPLERS (6).

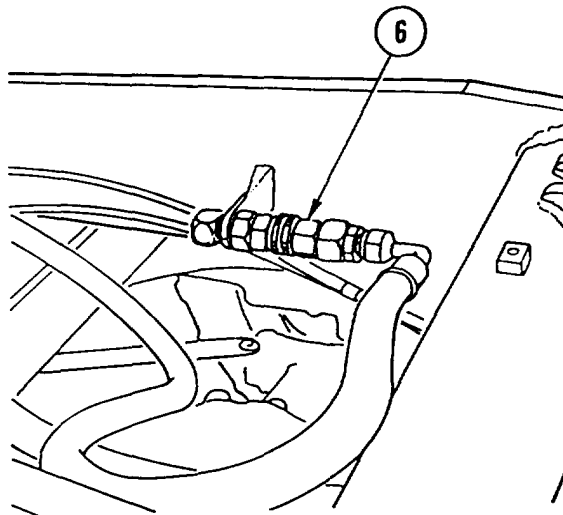

7. CONNECT hydraulic HOSE (7).

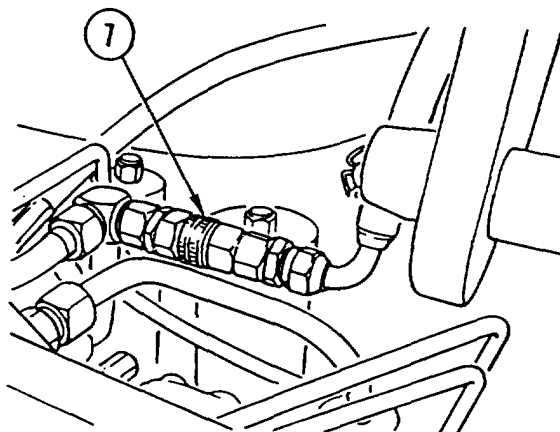

8. CONNECT hydraulic HOSE (8) and START VEHICLE.

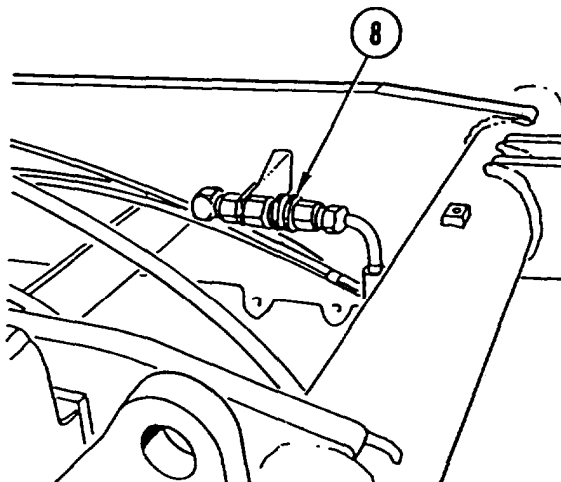

BACKHOE ASSEMBLY REPLACEMENT (CONT)

9. EXTEND tilt CYLINDER (9) to align with mounting eye and ENGAGE backhoe lock CYLINDERS.

NOTE

Insert tapered end of pin first.

10. CONNECT tilt CYLINDER (9) by INSTALLING PIN (10) and two snap rings (11).

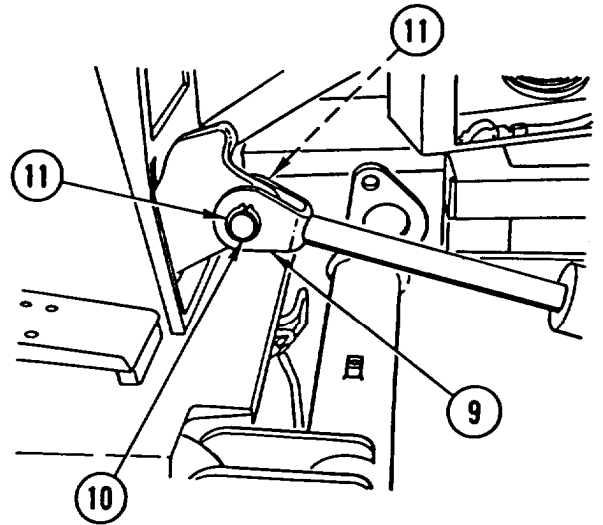

NOTE

- Use stabilizers and backhoe to assist in aligning holes for pin installation.
- Insert tapered end of mounting pins first.

11. INSTALL two mounting PINS (12) and four snap rings (13).

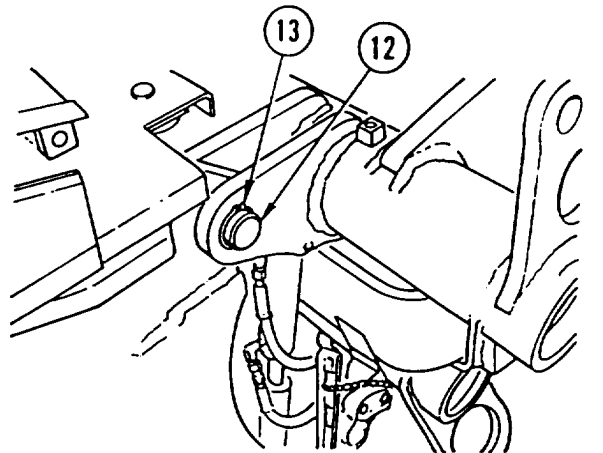

12. INSTALL BOX (4) and four screws (3).
13. INSTALL two WIRES (2) and two nuts (1) and CAREFULLY ROLL rubber BOOTS OVER connection.

NOTE

Follow-on Maintenance:

Install rear composite stoplight/taillight (page 4-190).
 Install work light (page 4-186).
 Install backhoe subframe deck (page 4-362).
 Check rear hydraulic tank (TM 5-2420-224-10).

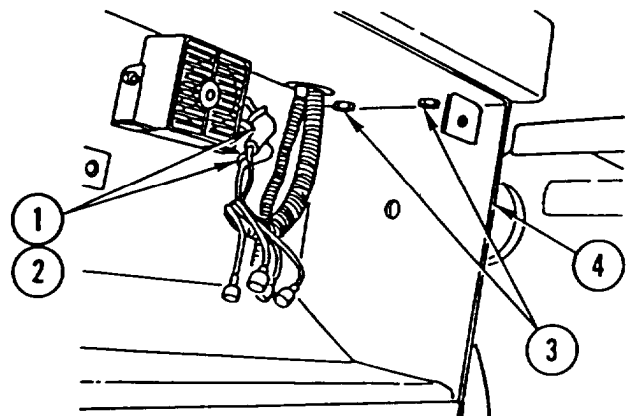

BACKHOE DIPPER REPLACEMENT AND REPAIR

This task covers: a. Removal b. Installation

INITIAL SETUP

Applicable Configuration:

SEE

Tools and Special Equipment:

Shop Equipment, SC 4910-95-CL-A74
Tool Kit, SC 5180-90-CL-N26

Personnel Required: (3)

References:

TM 5-2420-224-10

Equipment Condition:

Reference	Condition Description
Page 2-22	Backhoe in Three-Point Stance
TM 5-2420-224-10	Front Loader Lowered to Ground
Page 4-668	Backhoe Bucket Cylinder Removed
Page 4-762	Backhoe Bucket Removed

General Safety Instructions:

WARNING

- Backhoe dipper weighs 410 pounds (186 kilograms). To avoid personal injury, use a hoist or suitable lifting device when lifting backhoe dipper.
- Backhoe dipper must be as low to the ground as possible to prevent possible injury to personnel.

REMOVAL

CAUTION

Before performing step 1, place a block of wood between dipper cylinder and boom to prevent damage to equipment.

1. REMOVE two retaining rings (1), washers (2) if present, and PIN (3).
2. USING suitable HOIST, LOWER dipper CYLINDER (4). TIE to boom (5).
3. REMOVE two retaining rings (6), washers (7) if present, pin (8), and DIPPER (9).
4. If damaged, REMOVE BUSHING(S) (10, 11, 12, 13, and 14).

BACKHOE DIPPER REPLACEMENT AND REPAIR (CONT)

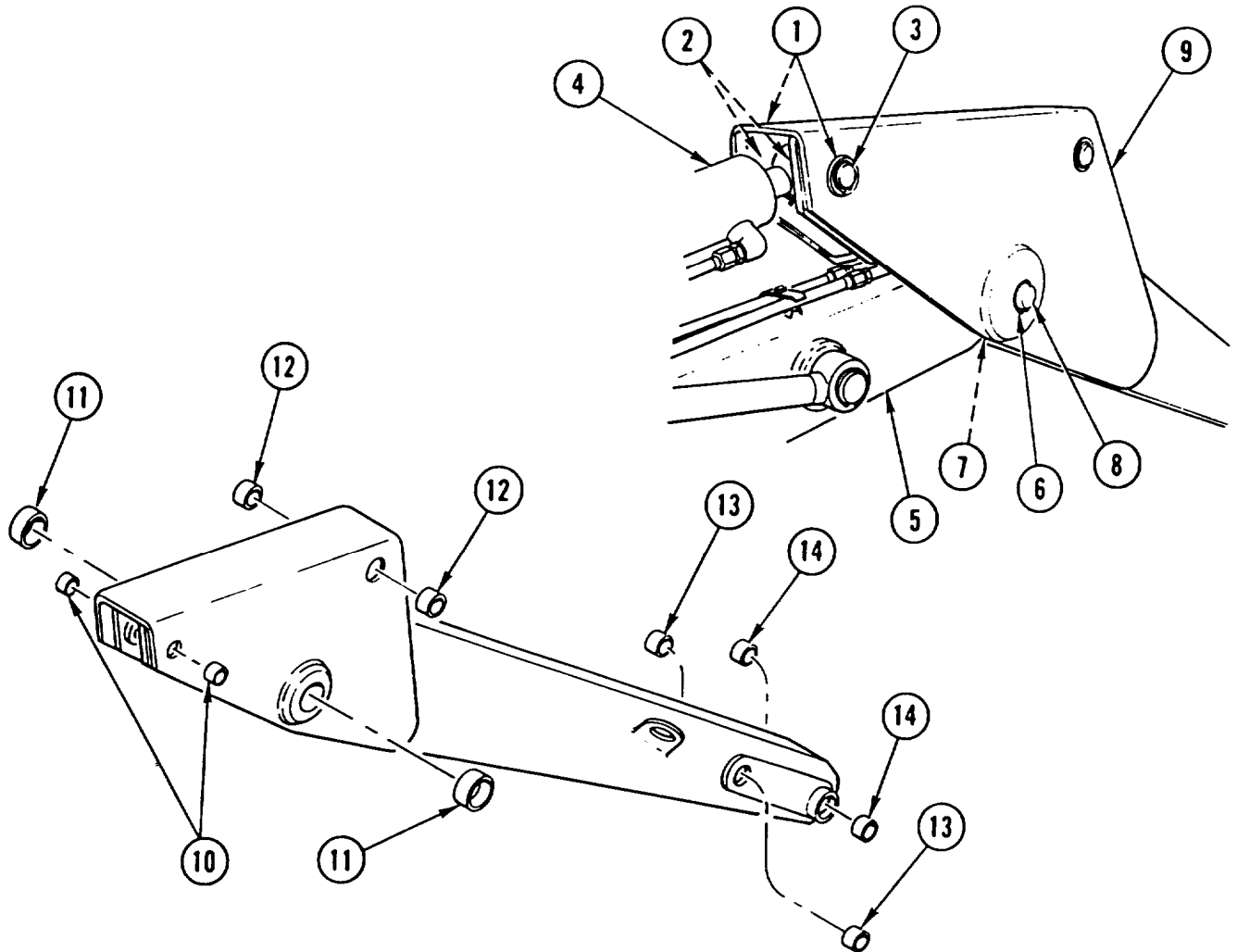

INSTALLATION

1. IF REMOVED, INSTALL new BUSHING(S) (10, 11, 12, 13, and 14).
2. INSTALL DIPPER (9), washers (7) if needed, pin (8), and two retaining rings (6).
3. REMOVE TIE holding dipper cylinder (4) to boom (5).
4. USING suitable HOIST, LIFT dipper CYLINDER (4) into place and INSTALL washers (2) if needed, PIN (3), and two retaining rings (1).

NOTE

Follow-on Maintenance:

Install backhoe bucket cylinder (page 4-668).
 Install backhoe bucket (page 4-762).

BACKHOE BUCKET REPLACEMENT

This task covers: a. Removal b. Installation

INITIAL SETUP

Applicable Configuration:

SEE

Tools and Special Equipment:

Shop Equipment, SC 4910-95-CL-A74
Tool Kit, SC 5180-90-CL-N26

References:

TM 5-2420-224-10

Equipment Condition:

Reference

TM 5-2420-224-10

Page 2-22

Condition Description

Front Loader Lowered to Ground

Backhoe in Three-Point Stance

REMOVAL

1. REMOVE two retaining rings (1), washers (2), and ROD (3).
2. REMOVE retaining ring (4), washers (5), tapered PIN (6), and sleeve spacer (7).
3. START ENGINE. RAISE DIPPER AWAY from backhoe bucket (8).

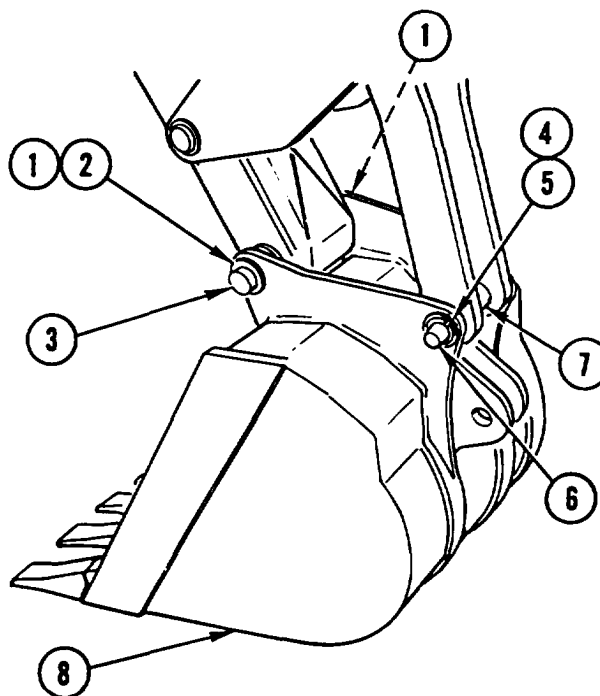

INSTALLATION

1. START ENGINE and POSITION DIPPER in mounting bracket of backhoe bucket (8).
2. INSTALL sleeve spacer (7), tapered PIN (6), washers (5) as needed, and retaining ring (4).
3. INSTALL ROD (3), washers (2) as needed, and two retaining rings (1).

BACKHOE BUCKET (RIPPER) BEARINGS REPLACEMENT

This task covers: a. Removal b. Installation

INITIAL SETUP

Applicable Configuration:

SEE

Tools and Special Equipment:

Tool Kit, SC 5180-90-CL-N26

Materials/Parts:

Bearing (2)

Bearing (2)

Oil, Lubricating Appendix C, Item 22

Personnel Required: (2)

Equipment Condition:

Reference

Page 4-762

Condition Description

Backhoe Bucket Removed

REMOVAL

NOTE

Following procedure applies only to ripper bucket P/N 419 559 70 20.

REMOVE and DISCARD four BEARINGS (1) from bucket (2).

INSTALLATION

NOTE

Following procedure applies only to ripper bucket P/N 419 559 70 20.

APPLY COAT of LUBRICATING OIL to four new BEARINGS (1) and INSTALL four BEARINGS (1) in bucket (2).

NOTE

Follow-on Maintenance:
Install backhoe bucket (page 4-762).

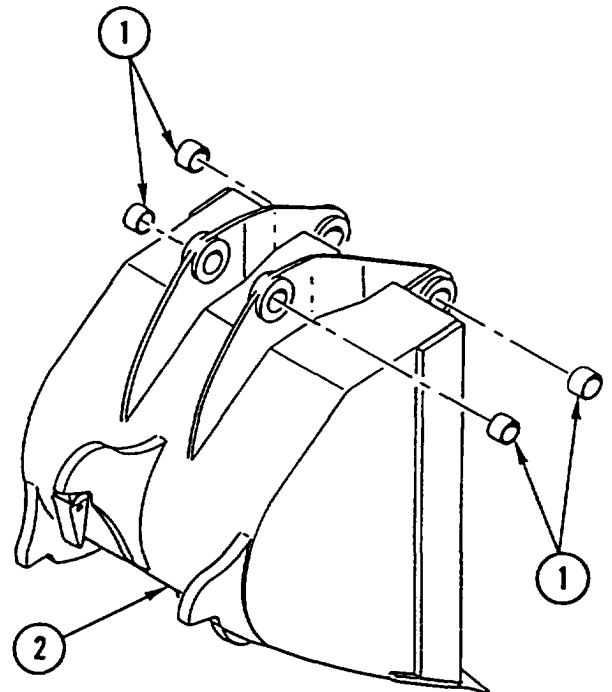

BACKHOE BUCKET LINKS REPLACEMENT

This task covers: a. Removal b. Installation

INITIAL SETUP

Applicable Configuration:

SEE

Equipment Condition:

Reference

Page 4-762

Condition Description

Backhoe Bucket Removed

Tools and Special Equipment:

Shop Equipment, SC 4910-95-CL-A74
Tool Kit, SC 5180-90-CL-N26

REMOVAL

NOTE

In steps 1 and 2, quantity of washers may vary.

1. REMOVE two retaining rings (1), washer(s) (2), pin (3), and two connecting LINKS (4).
2. REMOVE two retaining rings (5), washer(s) (6), pin (7), and two LINKS (8).
3. REMOVE four BUSHINGS (9) from two connecting links (4).
4. REMOVE four BUSHINGS (10) from two links (8).

INSTALLATION

1. INSTALL four BUSHINGS (10) in two links (8).
2. INSTALL four BUSHINGS (9) in two connecting links (4).

NOTE

in steps 3 and 4, install only enough washers to remove excess slack between dipper, dipper cylinder, and links.

3. INSTALL two LINKS (8), pin (7), washer(s) (6), and two retaining rings (5).
4. INSTALL two connecting LINKS (4), pin (3), washer(s) (2), and two retaining rings (1).

NOTE

Follow-on Maintenance:
Install backhoe bucket (page 4-762).

BACKHOE BUCKET LINKS REPLACEMENT (CONT)

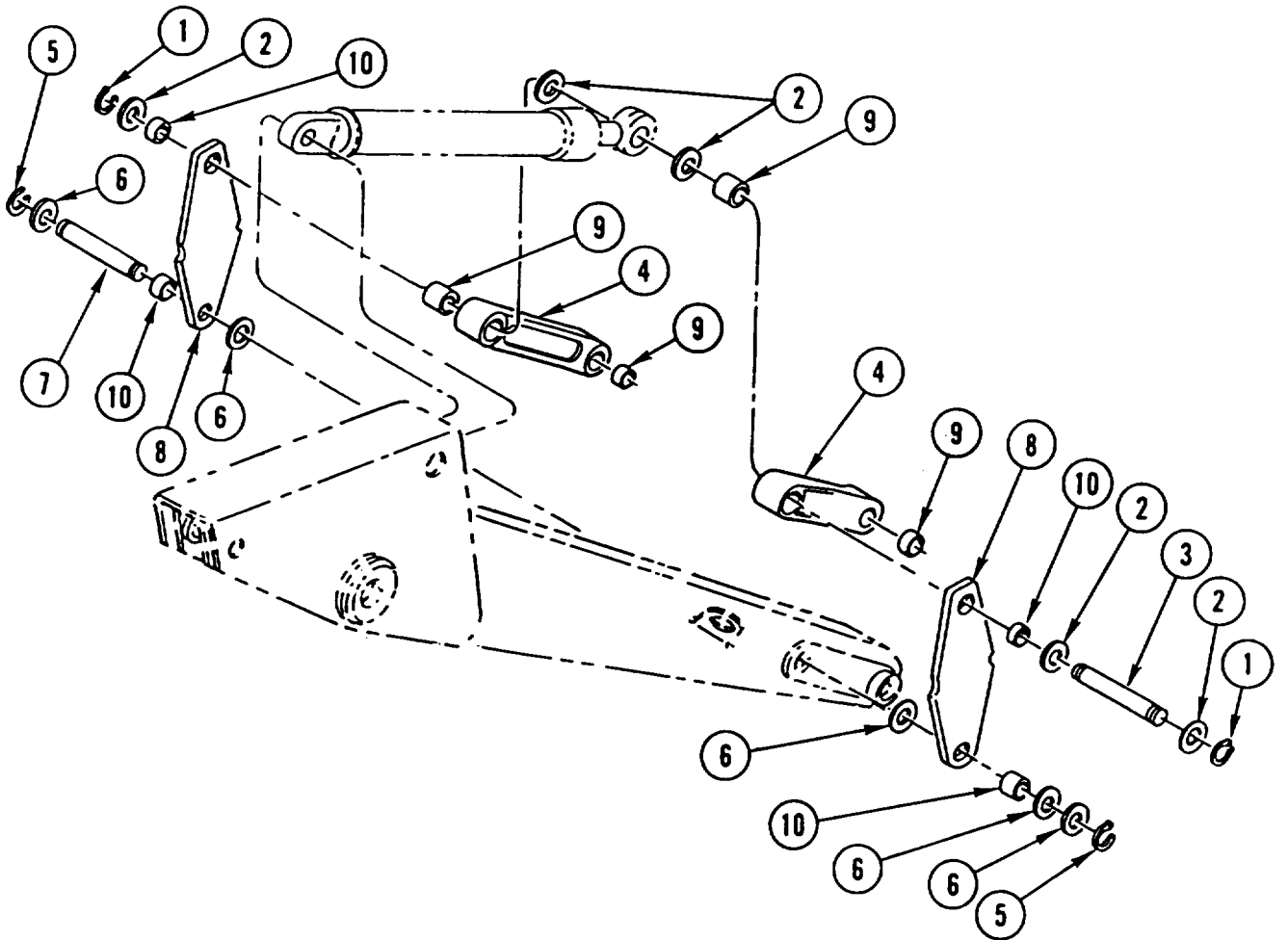

BACKHOE BUCKET/RIPPER TOOTH REPLACEMENT

This task covers: a. Removal b. Installation

INITIAL SETUP

Applicable Configuration:

SEE

Tools and Special Equipment:

Tool Kit, SC 5180-90-CL-N26

Materials/Parts:

Pin, Grooved (6)

General Safety Instructions:

WARNING

Backhoe bucket ripper shank assembly weighs 42 pounds (19 kilograms). To avoid personal injury, use a hoist or suitable lifting device when lifting backhoe bucket ripper shank assembly.

REMOVAL

1. ROLL BUCKET (1) FORWARD so that ripper shank assembly (2) is elevated.
2. REMOVE lock pin (3), pin (4), and ripper SHANK assembly (2) from bucket (1).
3. REMOVE and DISCARD grooved PIN (5).
4. REMOVE ripper TOOTH (6) from ripper shank assembly (2).
5. ROLL BUCKET (1) BACK so that bucket teeth (7) are elevated.
6. REMOVE and DISCARD grooved PIN (8).
7. REMOVE bucket TOOTH (7) from tooth shank (9).
8. REPEAT STEPS 6 and 7 for each bucket tooth (7).

INSTALLATION

1. INSTALL ripper TOOTH (6) on ripper shank assembly (2) until holes are alined.
2. INSTALL new grooved PIN (5).
3. INSTALL ripper SHANK assembly (2), pin (4), and lock pin (3) on bucket (1).
4. INSTALL bucket TOOTH (7) on tooth shank (9) until holes are alined.
5. INSTALL new grooved PIN (8).
6. REPEAT STEPS 4 and 5 for each bucket tooth (7).

BACKHOE BUCKET/RIPPER TOOTH REPLACEMENT (CONT)

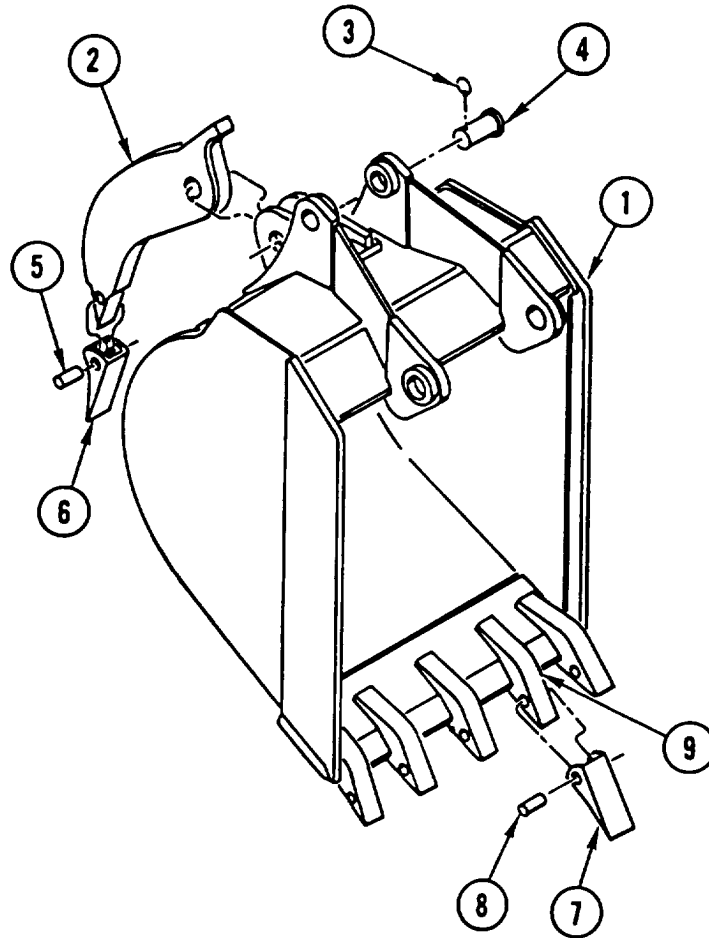

BACKHOE BOOM LATCH RELEASE LEVER REPLACEMENT

This task covers: a. Removal b. Installation

INITIAL SETUP

Applicable Configuration:

SEE

Equipment Condition:

Reference

Page 2-22

Condition Description

Backhoe in Three-Point Stance

Tools and Special Equipment:

Tool Kit, SC 5180-90-CL-N26

Materials/Parts:

Nut, Lock (6)

Washer, Lock (2)

REMOVAL

1. REMOVE six lock nuts (1), six screws (2), and GUARD (3) from plate assembly (4). DISCARD lock NUTS.
2. REMOVE SPRING (5) from plate assembly (4) and boom rod (6).
3. REMOVE two nuts (7), two lock washers (8), two screws (9), and latch SUPPORT (10) from plate assembly (4). DISCARD lock WASHERS.
4. REMOVE nut (11), boom rod (6), and boom latch release LEVER (12) from plate assembly (4).
5. REMOVE nut (13), BELLOWS (14), and knob (15) from boom latch release lever (12).

INSTALLATION

1. INSTALL knob (15), BELLOWS (14), and nut (13) on boom latch release lever (12).
2. INSTALL boom latch release LEVER (12), boom rod (6), and nut (11).
3. INSTALL latch SUPPORT (10), two screws (9), two new lock washers (8), and two nuts (7) on plate assembly (4).
4. INSTALL SPRING (5) between boom rod (6) and plate assembly (4).
5. INSTALL GUARD (3), six screws (2), and six new lock nuts (1) on plate assembly (4).

BACKHOE BOOM LATCH RELEASE LEVER REPLACEMENT (CONT)

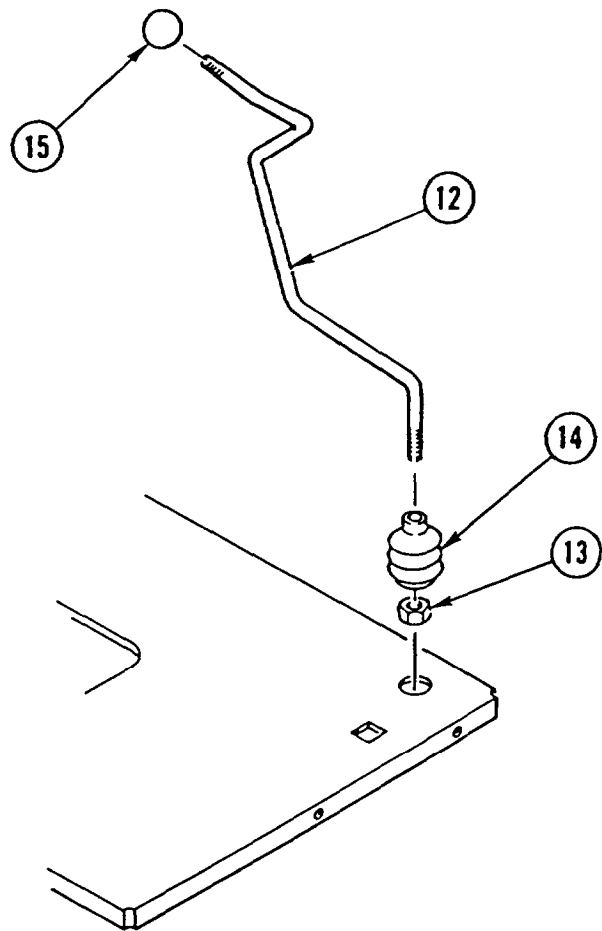
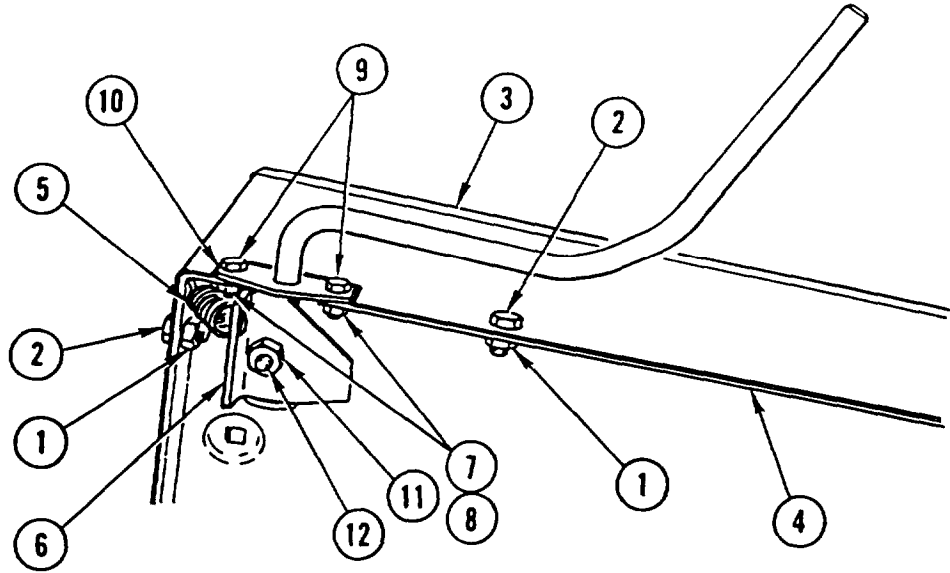

BACKHOE BOOM LATCH REPLACEMENT

This task covers: a. Removal b. Installation

INITIAL SETUP

Applicable Configuration:

SEE

Equipment Condition:

Reference

Page 2-22

Condition Description

Backhoe in Three-Point
Stance

Tools and Special Equipment:

Tool Kit, SC 5180-90-CL-N26

Materials/Parts:

Pin, Spring

REMOVAL

1. REMOVE capscrew (1), MOUNT (2), boom support (3), shim (4), spacer (5), and bar (6).
2. REMOVE nut (7), washer (8), and CAPSCREW (9).
3. REMOVE bolt (10), washer (11), and two STRAPS (12).
4. REMOVE spring pin (13), pin (14), and boom LATCH (15). DISCARD spring PIN.

INSTALLATION

1. INSTALL boom LATCH (15), pin (14), and new spring pin (13).
2. INSTALL two STRAPS (12), washer (11), and bolt (10).
3. INSTALL CAPSCREW (9), washer (8), and nut (7).
4. INSTALL bar (6), spacer (5), shim (4), boom support (3), MOUNT (2), and capscrew (1).

BACKHOE BOOM LATCH REPLACEMENT (CONT)

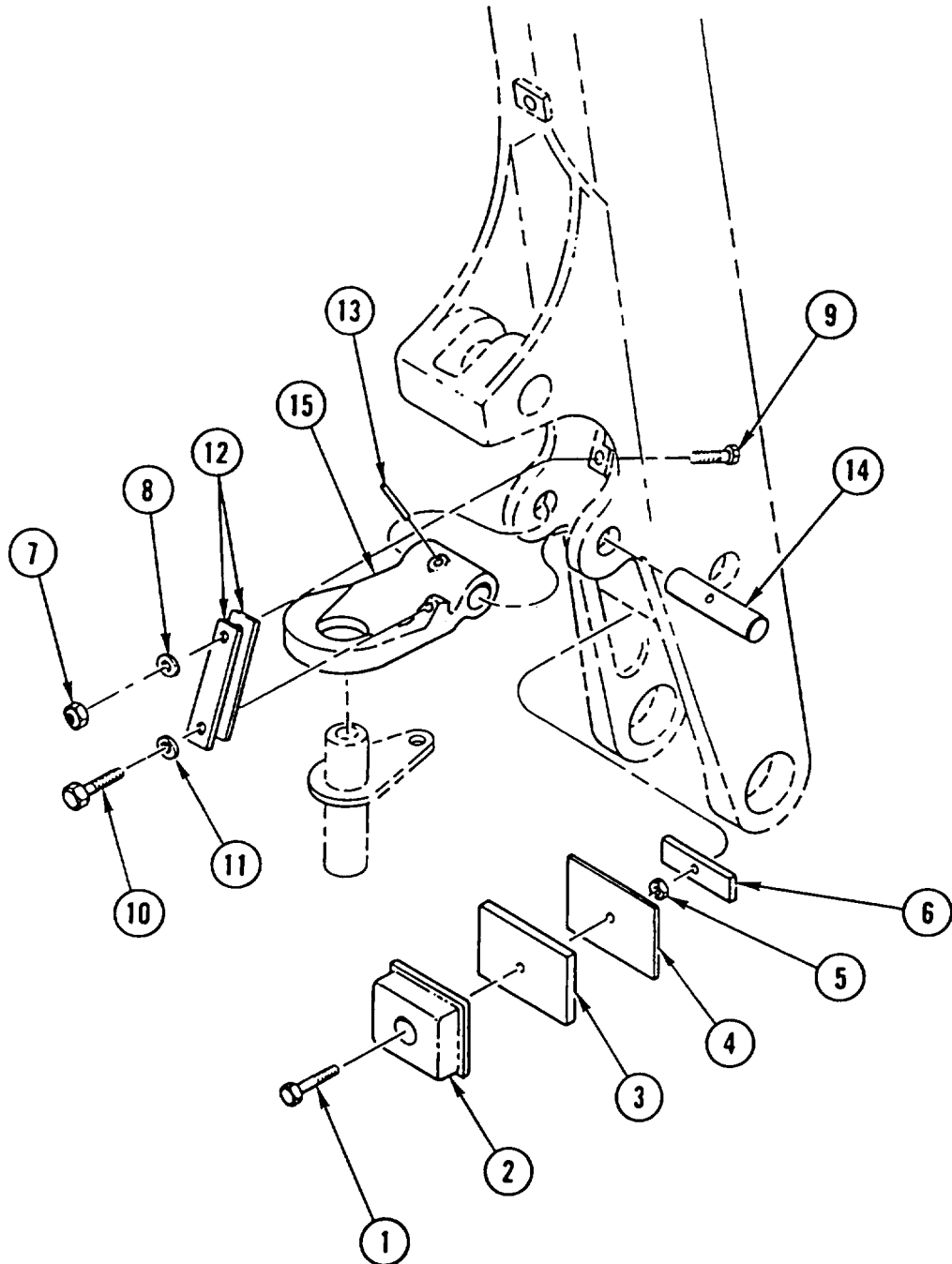

BACKHOE SWING TOWER REPLACEMENT

This task covers: a. Removal b. Installation

INITIAL SETUP

Applicable Configuration:

SEE

Tools and Special Equipment:

Shop Equipment, SC 4910-95-CL-A74
 Tool Kit, SC 5180-90-CL-N26

Materials/Parts:

Nut, Lock

Oil, Lubricating Appendix C, Item 22

Personnel Required: (2)

References:

TM 5-2420-224-10

Equipment Condition:

Reference	Condition Description
Page 4-660	Backhoe Swing Cylinders Removed
Page 4-658	Backhoe Boom Cylinders Removed
Page 4-612	Backhoe Control Valve, Boom Section Hydraulic Lines and Fittings Removed

Equipment Condition (Cont):

Reference	Condition Description
Page 4-614	Backhoe Dipper Cylinder Hydraulic Lines and Fittings Removed
Page 4-618	Backhoe Control Valve, Bucket Section Hydraulic Lines and Fittings Removed

General Safety Instructions:

W A R N I N G

- Backhoe boom assembly with dipper assembly weighs 1,459 pounds (663 kilograms). To avoid personal injury, use a hoist or suitable lifting device when lifting backhoe boom assembly with dipper assembly.
- Backhoe swing tower weighs 308 pounds (140 kilograms). To avoid personal injury, use a hoist or suitable lifting device when lifting backhoe swing tower.

REMOVAL

1. REMOVE two capscrews (1), two edge washers (2), two washers (3), two pins (4), and BOOM and DIPPER assemblies (5).
2. REMOVE lock nut (6), capscrew (7), washer (8), PIN (9), and shim (10). DISCARD lock NUT.
3. IF DAMAGED, REMOVE lubrication FITTING (11).
4. REMOVE nut (12), pin (13), spacer (14), and swing TOWER (15).
5. IF DAMAGED, REMOVE lubrication FITTING (16).
6. USING HAMMER and BRASS DRIFT PIN, REMOVE eight BUSHINGS (17).

BACKHOE SWING TOWER REPLACEMENT (CONT)

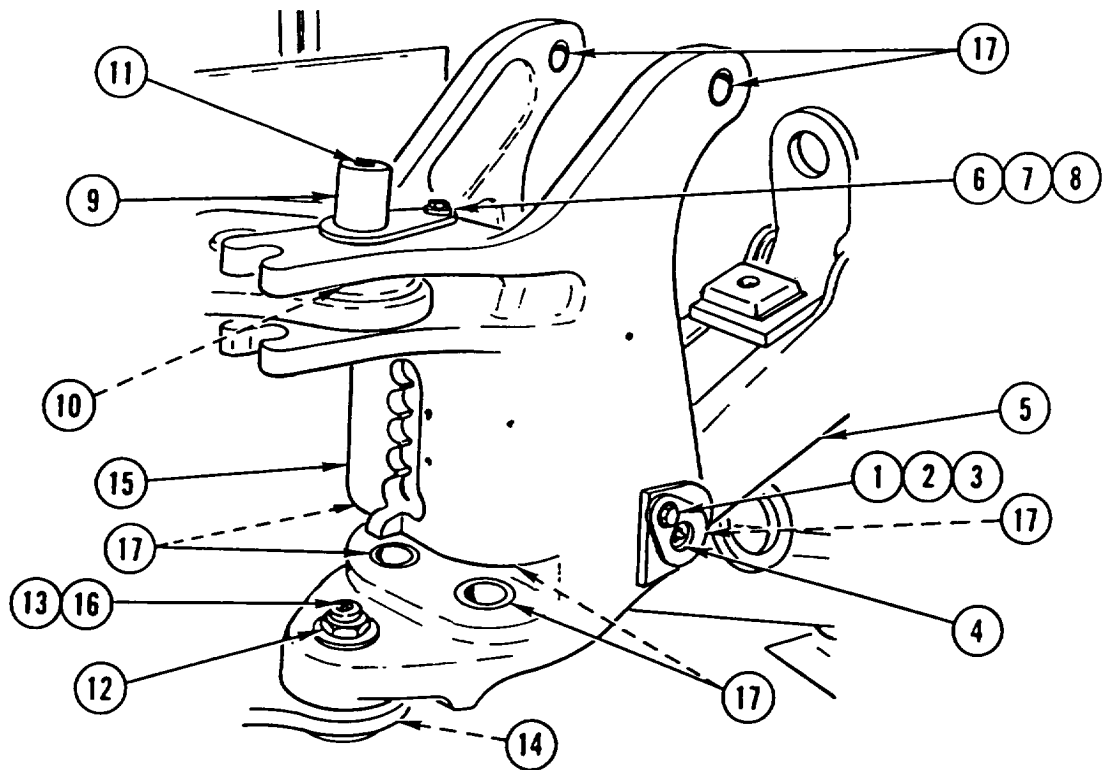

INSTALLATION

1. IF REMOVED, INSTALL new lubrication FITTING (16).
2. INSTALL swing TOWER (15), spacer (14), pin (13), and nut (12).
3. IF REMOVED, INSTALL new lubrication FITTING (11).
4. INSTALL shim (10), PIN (9), washer (8), capscrew (7), and new lock nut (6).
5. INSTALL BOOM and DIPPER assemblies (5), two pins (4), two washers (3), two edge washers (2), and two capscrews (1).
6. APPLY light COAT of LUBRICATING OIL to eight BUSHINGS (17).
7. INSTALL eight BUSHINGS (17).

NOTE

Follow-on Maintenance:

Install backhoe control valve, boom section hydraulic lines and fittings (page 4-612).
 Install backhoe dipper cylinder hydraulic lines and fittings (page 4-614).
 Install backhoe control valve, bucket section hydraulic lines and fittings (page 4-618).
 Install backhoe boom cylinders (page 4-658).
 Install backhoe swing cylinders (page 4-660).
 Check rear hydraulic tank (TM 5-2420-224-10).

BACKHOE STABILIZER REPLACEMENT

This task covers: a. Removal b. Installation

INITIAL SETUP

Applicable Configuration:

SEE

Tools and Special Equipment:

Shop Equipment, SC 4910-95-CL-A74
Tool Kit, SC 5180-90-CL-N26

Personnel Required: (2)

Equipment Condition:

Reference

Page 4-673

Condition Description

Backhoe Stabilizer
Cylinders Removed

General Safety Instructions:

WARNING

Backhoe stabilizer weighs 140 pounds (64 kilograms). To avoid personal injury, use a hoist or suitable lifting device when lifting backhoe stabilizer.

REMOVAL

NOTE

Procedure is the same for both backhoe stabilizers.

1. REMOVE two retaining rings (1) and four WASHERS (2).
2. REMOVE two retaining rings (3), flat WASHER (4), and bearing WASHER (5).
3. ATTACH suitable HOIST. REMOVE two PINS (6 and 7) and LIFT backhoe STABILIZER (8) clear of mounting frame (9) and stabilizer pad (10).
4. USING suitable PRESS, REMOVE two BUSHINGS (11) from backhoe stabilizer (8).

BACKHOE STABILIZER REPLACEMENT (CONT)

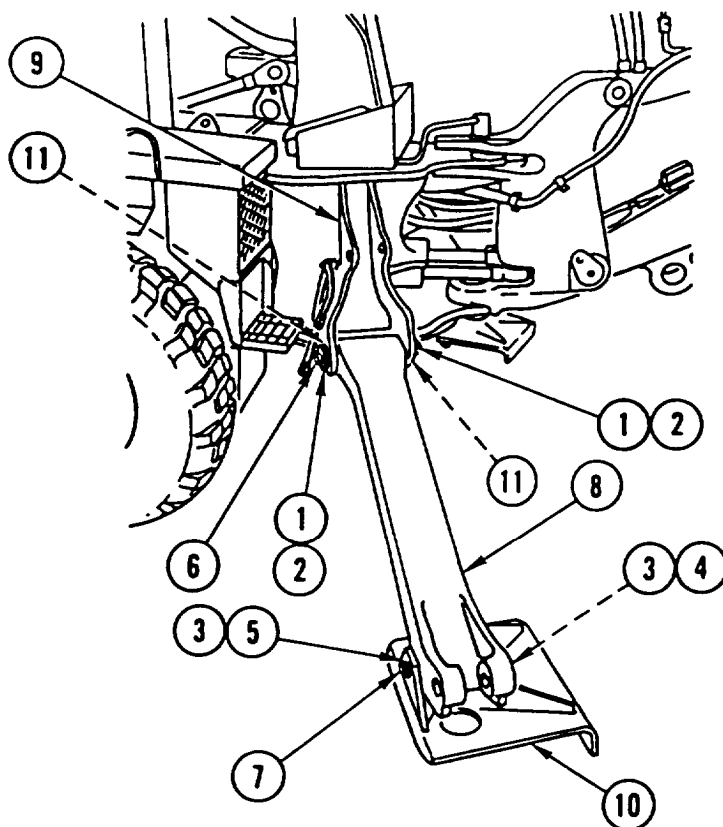
INSTALLATION
NOTE

Procedure is the same for both backhoe stabilizers.

1. USING suitable PRESS, INSTALL two BUSHINGS (11) in backhoe stabilizer (8).
2. ATTACH suitable HOIST. INSTALL backhoe STABILIZER (8) on mounting frame (9) and INSTALL PIN (6).
3. PLACE backhoe stabilizer PAD (10) in position under backhoe stabilizer (8) and INSTALL PIN (7).
4. INSTALL flat WASHER (4), bearing WASHER (5), and two retaining rings (3).
5. INSTALL four WASHERS (2) (two on each side) and two retaining rings (1).

NOTE

Follow-on Maintenance:
Install backhoe stabilizer cylinders (page 4-673).

CRANE REPLACEMENT

This task covers: a. Removal b. Installation

INITIAL SETUP

Applicable Configuration:

HMMH

Tools and Special Equipment:

Tool Kit, SC 5180-90-CL-N26

Materials/Parts:

Rags Appendix C, Item 32

Personnel Required: (2)

References:

TM 5-2420-224-10

Equipment Condition:

Reference	Condition Description
TM 5-2420-224-10	PTO Engaged
Page 4-186	Work Light Removed
Page 4-190	Rear Composite Stoplight/ Taillight Removed (Driver Side)
Page 2-23	Crane in Three-Point Stance

General Safety Instructions:

W A R N I N G

- HMMH should not be operated with crane removed, except in a maintenance facility. When maintenance is required and crane is removed, never operate HMMH at speeds greater than 5 mph. Tractor stability and handling characteristics are greatly affected with crane removed. This could cause loss of control and injury to personnel or damage to vehicle.
- High pressure hydraulics [oil under 2450 psi (16,893 kPa)] operate this equipment. Never disconnect any hydraulic line or fitting without first dropping pressure to zero. A high pressure oil stream can pierce body and cause severe injury to personnel.
- Fuel and oil are slippery and can cause falls. To avoid injury, wipe up spilled fuel or oil with rags.
- Do not connect or disconnect any electrical connector unless vehicle MASTER disconnect switch is OFF. To do so could result in injury to personnel.

CRANE REPLACEMENT (CONT)

REMOVAL

NOTE

Tag wires prior to removal to aid in installation.

1. CAREFULLY ROLL BACK rubber BOOTS and REMOVE two nuts (1) and two WIRES (2).
2. REMOVE four screws (3) and BOX (4).

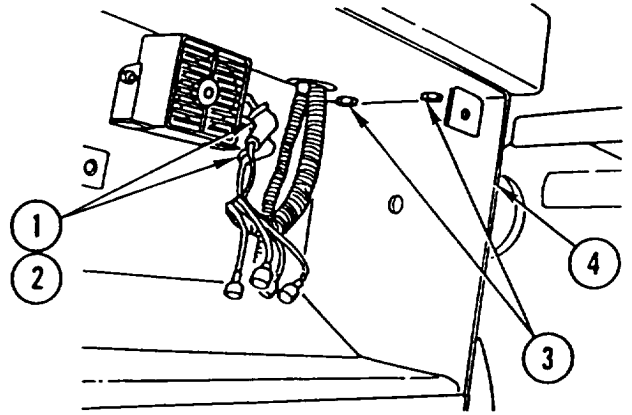

NOTE

In steps 3 and 4, it may be necessary to use outrigger and boom controls to remove pressure on pivot pins.

3. REMOVE two snap rings (5) and pivot PIN (6) on right side crane mounting.

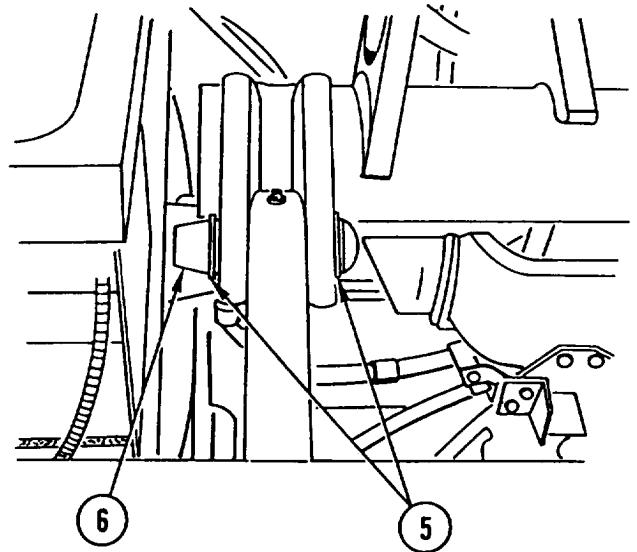

CRANE REPLACEMENT (CONT)

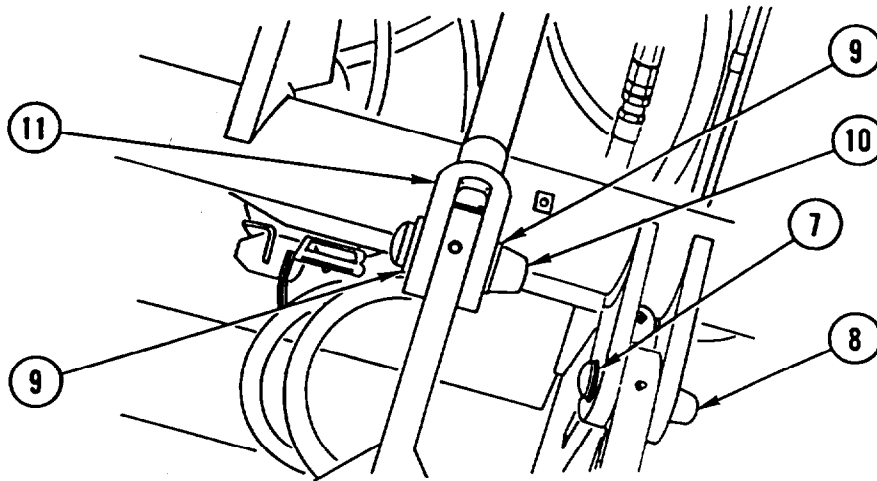

4. REMOVE two snap rings (7) and pivot PIN (8) on left side crane mounting.

NOTE

It may be necessary to use tilt control lever to take pressure off tilt cylinder pin.

5. REMOVE two snap rings (9) and tilt cylinder PIN (10) and DISCONNECT tilt CYLINDER (11).
6. START ENGINE, RETRACT tilt CYLINDER (11), and DISENGAGE crane LOCKS.

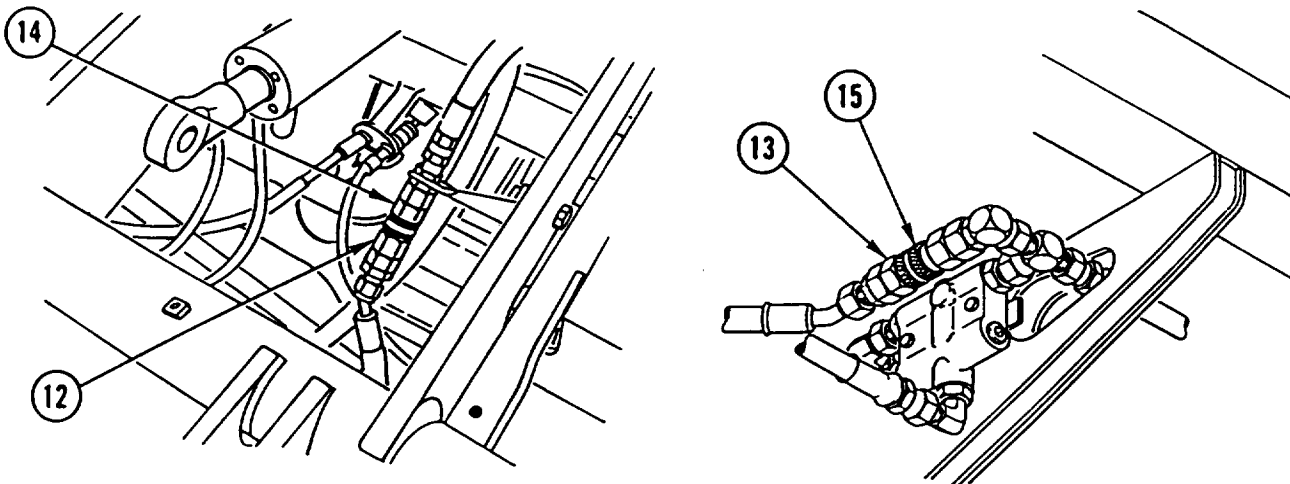

7. MOVE VEHICLE FORWARD 6-10 in. (15-25 cm) to gain access to hydraulic hose quick disconnects (12 and 13). STOP ENGINE and DISENGAGE PTO (TM 5-2420-224-10).
8. RELIEVE PRESSURE FROM HYDRAULIC SYSTEM (page 2-23) and DISCONNECT quick DISCONNECT (12) from connector (14).
9. DISCONNECT quick DISCONNECT (13) from connector (15).

CRANE REPLACEMENT (CONT)

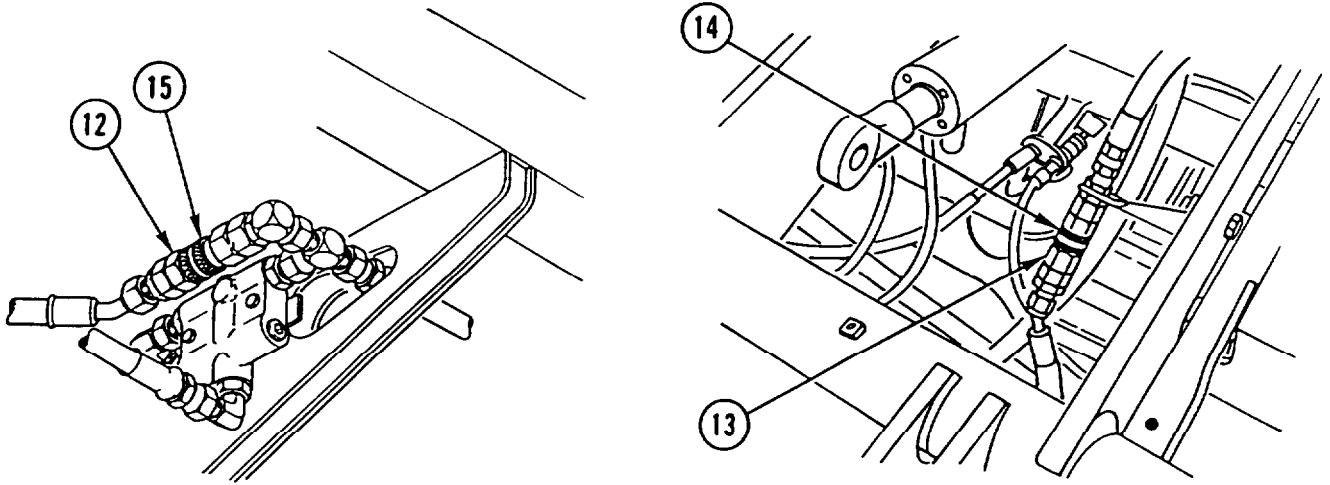

10. CONNECT quick DISCONNECT (12) to connector (15).

11. CONNECT quick DISCONNECT (13) to connector (14).

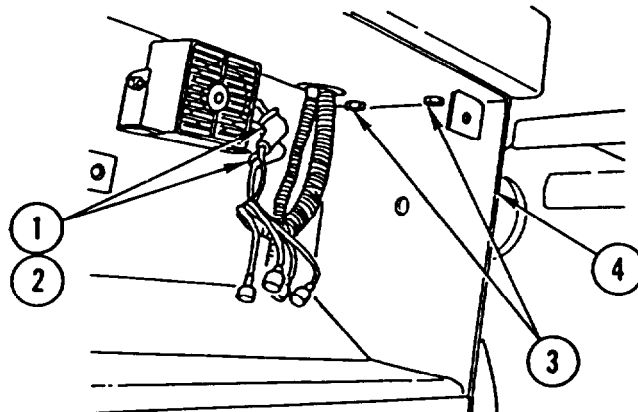

12. INSTALL BOX (4) and four screws (3).

13. INSTALL two WIRES (2) and two nuts (1) and CAREFULLY ROLL rubber BOOTS OVER connection.

14. INSTALL REAR COMPOSITE STOPLIGHT/TAILLIGHT (page 4-190).

15. INSTALL WORK LIGHT (page 4-186).

16. SLOWLY MOVE VEHICLE AWAY from crane assembly.

CRANE REPLACEMENT (CONT)

INSTALLATION

1. REMOVE WORK LIGHT (page 4-186).
2. REMOVE REAR COMPOSITE STOPLIGHT/TAILLIGHT (page 4-190).

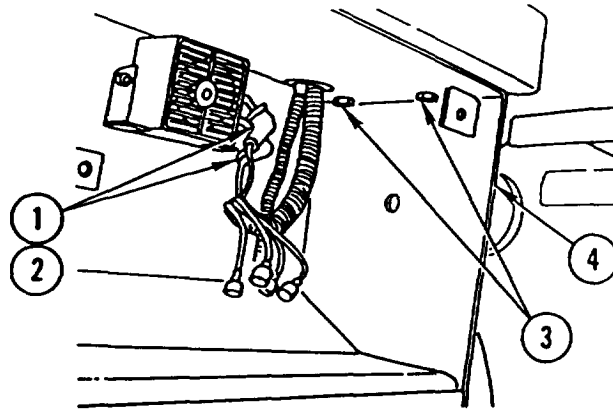

NOTE

Tag wires prior to removal to aid in installation.

3. CAREFULLY ROLL BACK rubber BOOTS and REMOVE two nuts (1) and two WIRES (2).
4. REMOVE four screws (3) and BOX (4).

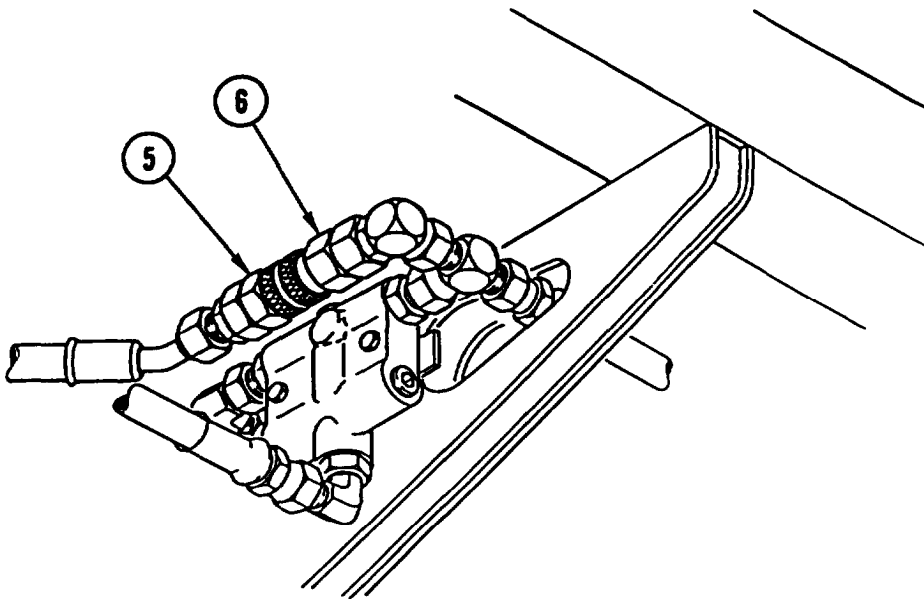

5. DISCONNECT quick DISCONNECT (5) from connector (6).

CRANE REPLACEMENT (CONT)

6. DISCONNECT quick DISCONNECT (7) from connector (8).

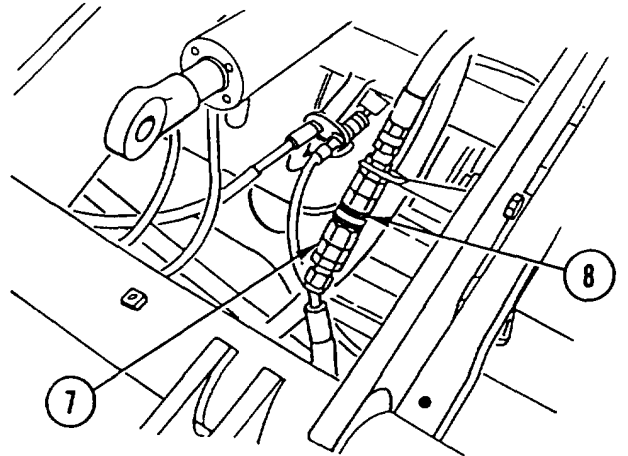

7. CONNECT quick DISCONNECT (7) to connector (6).

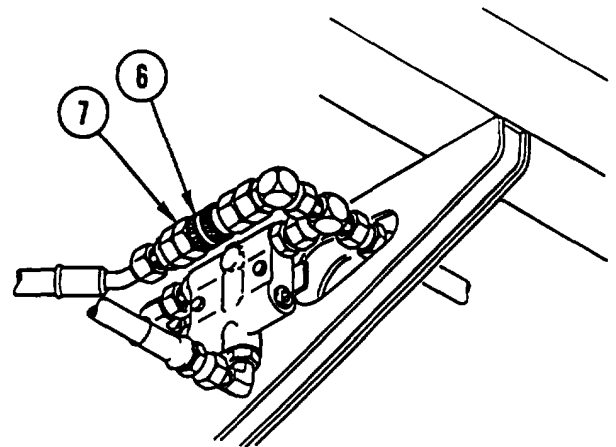

8. CONNECT quick DISCONNECT (5) to connector (8).

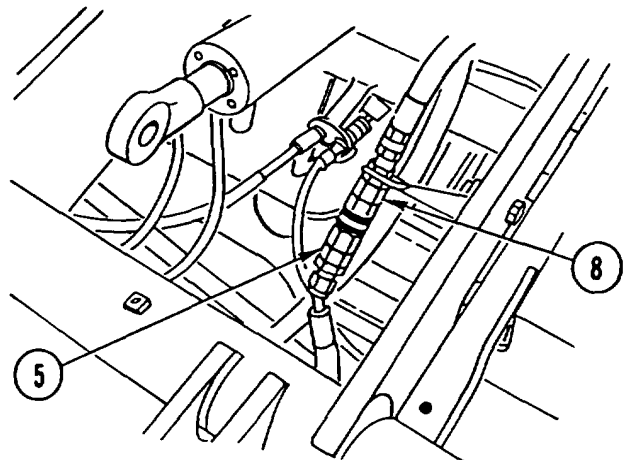

CRANE REPLACEMENT (CONT)

9. START ENGINE, EXTEND tilt CYLINDER (9) to align with mounting eye, and ENGAGE crane LOCKS.
10. CONNECT tilt CYLINDER (9) and INSTALL tilt cylinder PIN (10) and two snap rings (11).
11. INSTALL pivot PIN (12) and two snap rings (13) on left side crane mounting.

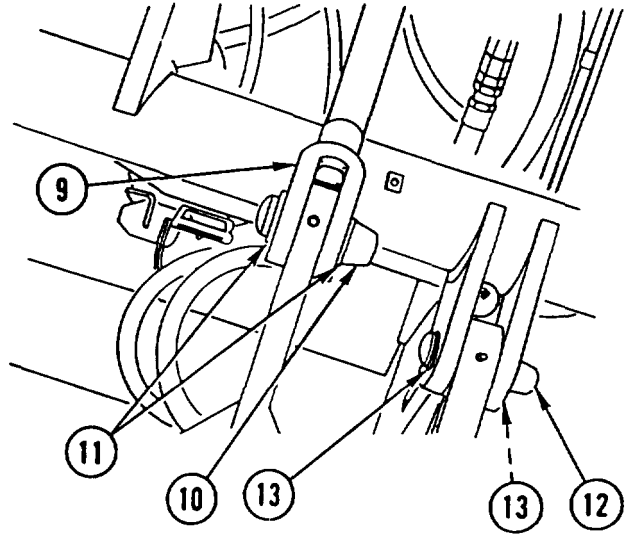

12. INSTALL pivot PIN (14) and two snap rings (15) on right side crane mounting.

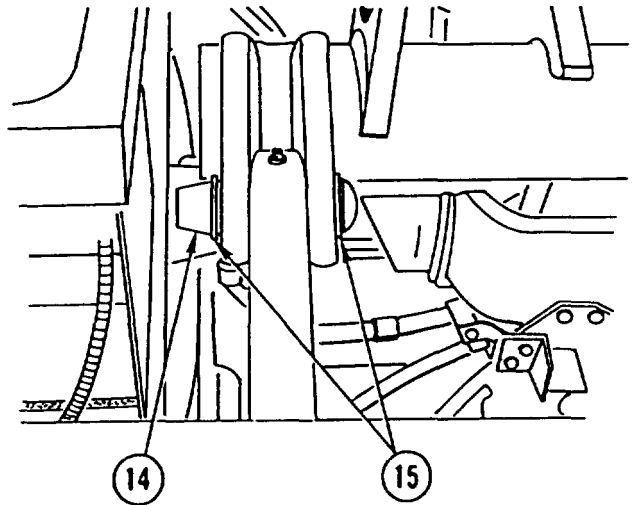

13. INSTALL BOX (4) and four screws (3).
14. INSTALL two WIRES (2) and two nuts (1) and CAREFULLY ROLL rubber BOOTS OVER connection.

NOTE

Follow-on Maintenance:
Install rear composite stoplight/
taillight (driver side) (page 4-190).
Install work light (page 4-186).

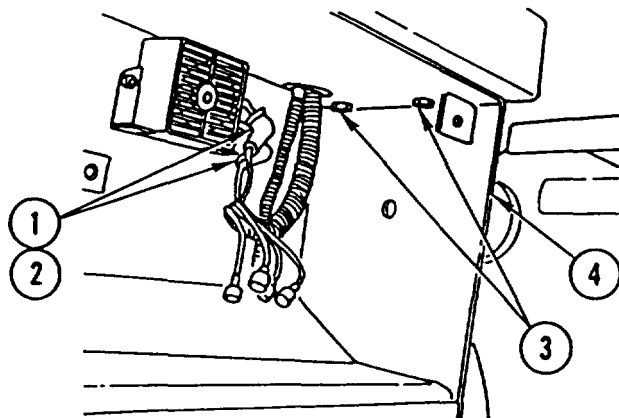

CRANE HOOK ASSEMBLY REPLACEMENT

This task covers: a. Removal b. Installation

INITIAL SETUP

Applicable Configuration:

HMMH

Materials/Parts:

Nut, Lock

Tools and Special Equipment:

Tool Kit, SC 5180-90-CL-N26

REMOVAL

1. REMOVE lock nut (1), capscrew (2), and HOOK (3) from extension boom (4). DISCARD lock NUT.
2. REMOVE hair pin (5), pin (6), and two LINKS (7).

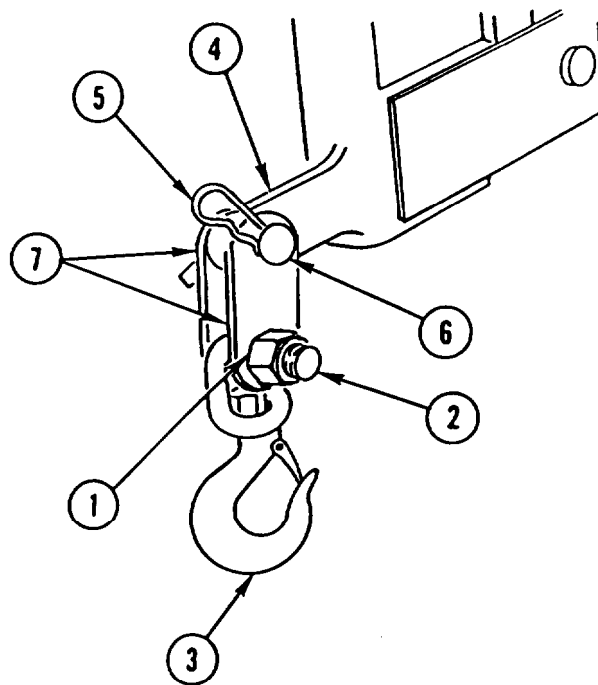

INSTALLATION

1. INSTALL two LINKS (7), pin (6), and hair pin (5) on extension boom (4).
2. INSTALL HOOK (3), capscrew (2), and new lock nut (1).

CRANE REAR OUTRIGGER REPLACEMENT

This task covers: a. Removal b. Installation

INITIAL SETUP

Applicable Configuration:

HMMH

Tools and Special Equipment:

Shop Equipment, SC 4910-95-CL-A74
Tool Kit, SC 5180-90-CL-N26

Materials/Parts:

Nut, Lock

Nut, Lock

Personnel Required: (2)

REMOVAL

NOTE

Procedure is the same for both rear outriggers.

1. REMOVE hair pin (1) and PIN (2).
2. REMOVE two retaining rings (3), pin (4), and PAD (5).
3. REMOVE CRANE VERTICAL OUTRIGGER CYLINDER (6) (page 4-700).
4. REMOVE outrigger LEG (7) from outrigger housing (8).

NOTE

Tag lines prior to removal to aid in installation.

5. REMOVE lock nut (9) and hose CLAMP (10) and SET HOSES (11 and 12) out of the way. DISCARD lock NUT.
6. REMOVE lock nut (13) and CAPSCREW (14) from horizontal cylinder rod end (15). DISCARD lock NUT.
7. RETRACT horizontal cylinder rod END (15).
8. REMOVE outrigger HOUSING (8).

CRANE REAR OUTRIGGER REPLACEMENT (CONT)

INSTALLATION

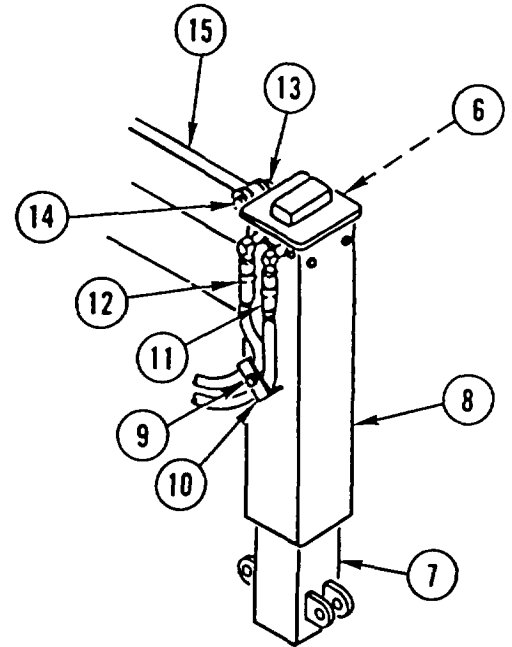
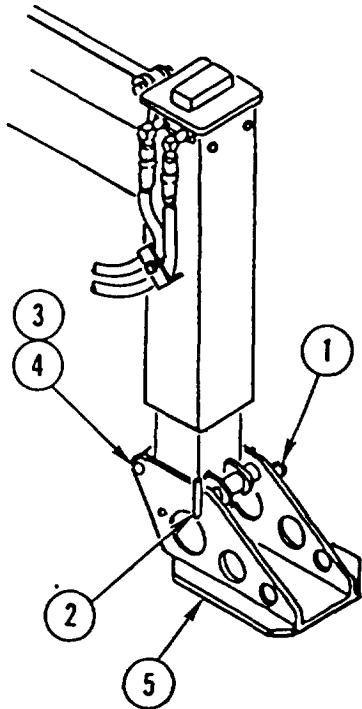
**NOTE**

Procedure is the same for both rear outriggers.

1. INSTALL outrigger HOUSING (8).
2. EXTEND horizontal cylinder rod END (15).
3. INSTALL CAPSCREW (14) and new lock nut (13) in horizontal cylinder rod end (15).
4. POSITION HOSES (11 and 12) and INSTALL hose CLAMP (10) and new lock nut (9).
5. INSTALL outrigger LEG (7) in outrigger housing (8).
6. INSTALL CRANE VERTICAL OUTRIGGER CYLINDER (6) (page 4-700).
7. INSTALL PAD (5), pin (4), and two retaining rings (3).
8. INSTALL PIN (2) and hair pin (1).

CRANE TRAVEL LOCK REPLACEMENT AND ADJUSTMENT

This task covers: a. Removal b. Installation c. Adjustment

INITIAL SETUP

Applicable Configuration:

HMMH

References:

TM 5-2420-224-10

Tools and Special Equipment:

Tool Kit, SC 5180-90-CL-N26

Equipment Condition:

Reference

Page 2-23

Condition Description

Crane in Three-Point Stance

Materials/Parts:

Strap, Tiedown

Nut, Lock (2)

REMOVAL

1. HOLD NUT (1) and REMOVE KNOB (2).
2. REMOVE two NUTS (1 and 3).
3. REMOVE CONTROL assembly (4) from bracket (5).
4. REMOVE two nuts (6), two bolts (7), and BRACKET (5).
5. REMOVE and DISCARD tiedown STRAP (8).
6. REMOVE spring PIN (9).
7. LOOSEN NUT (10) and REMOVE CONTROL assembly (4) from rear of mounting bracket (11).
8. REMOVE PIN (12) from mounting bracket (11).
9. REMOVE PIN (13) and pin (12) from control assembly (4).
10. LOOSEN NUT (14) and REMOVE ADAPTER (15) from control assembly (4).
11. REMOVE CONTROL assembly (4) from mounting bracket (11).
12. REMOVE SPRING (16) from mounting bracket (11).
13. REMOVE four nuts (17), four capscrews (18), and MOUNT (19).
14. REMOVE two lock nuts (20), two capscrews (21), and mounting BRACKET (11). DISCARD lock NUTS.
15. IF DAMAGED, REMOVE lubrication FITTING (22) and BUSHING (23) from pin (12).

CRANE TRAVEL LOCK REPLACEMENT AND ADJUSTMENT (CONT)

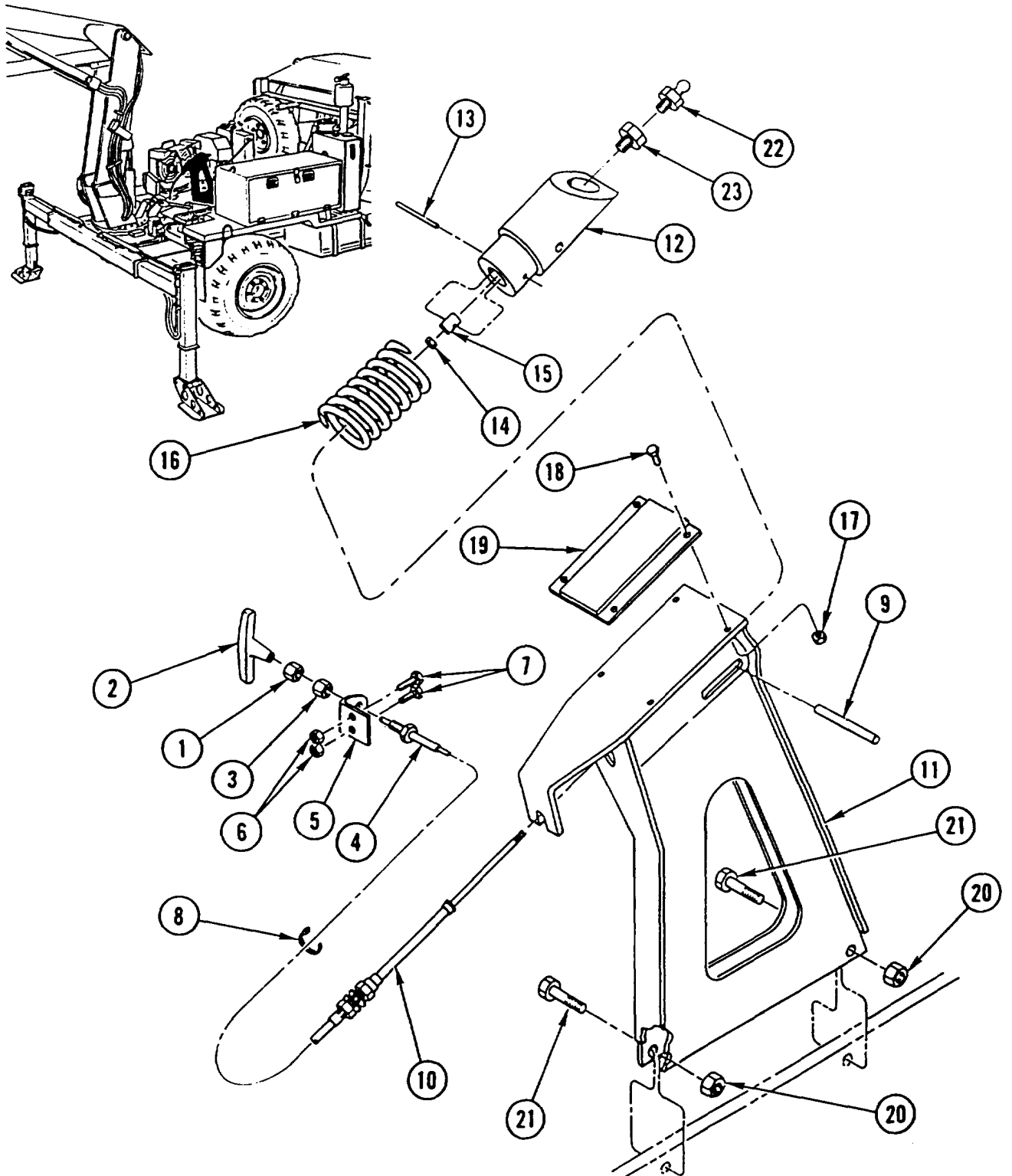

CRANE TRAVEL LOCK REPLACEMENT AND ADJUSTMENT (CONT)

INSTALLATION

1. IF REMOVED, INSTALL new BUSHING (1) and new lubrication FITTING (2).
2. INSTALL mounting BRACKET (3), two capscrews (4), and two new lock nuts (5).
3. INSTALL MOUNT (6), four capscrews (7), and four nuts (8).
4. INSTALL SPRING (9) in mounting bracket (3).
5. INSTALL CONTROL assembly (10) all the way into mounting bracket (3).
6. INSTALL ADAPTER (11) on control assembly (10) and TIGHTEN NUT (12).
7. INSTALL PIN (13) and pin (14) on control assembly (10).
8. INSTALL PIN (13) in mounting bracket (3).
9. INSTALL CONTROL assembly (10) in rear of mounting bracket (3) and TIGHTEN NUT (15).
10. INSTALL spring PIN (16).
11. INSTALL new tiedown STRAP (17).
12. INSTALL BRACKET (18), two bolts (19), and two nuts (20).
13. INSTALL CONTROL assembly (10) in bracket (18).
14. INSTALL two NUTS (21 and 22).
15. INSTALL KNOB (23) on control assembly (10).

ADJUSTMENT

1. Place crane in transport position (TM 5-2420-224-10).
2. Make sure pin (1) is completely engaged in crane latch bail (2).

NOTE

Perform step 3 only if pin is not completely engaged in crane latch bail. If completely engaged, go to step 4.

3. Loosen nut (3) to extend pin (1) into crane latch bail (2). Tighten nut (4).
4. Make sure pin (1) is completely disengaged from crane latch bail (2) when placing crane in upright position.

NOTE

Perform step 5 only if pin does not completely disengage.

5. Loosen nut (4) and pull pin (1) back enough to completely disengage. Tighten nut (3).
6. Repeat steps 1 thru 5 until adjustments are achieved.

CRANE TRAVEL LOCK REPLACEMENT AND ADJUSTMENT (CONT)

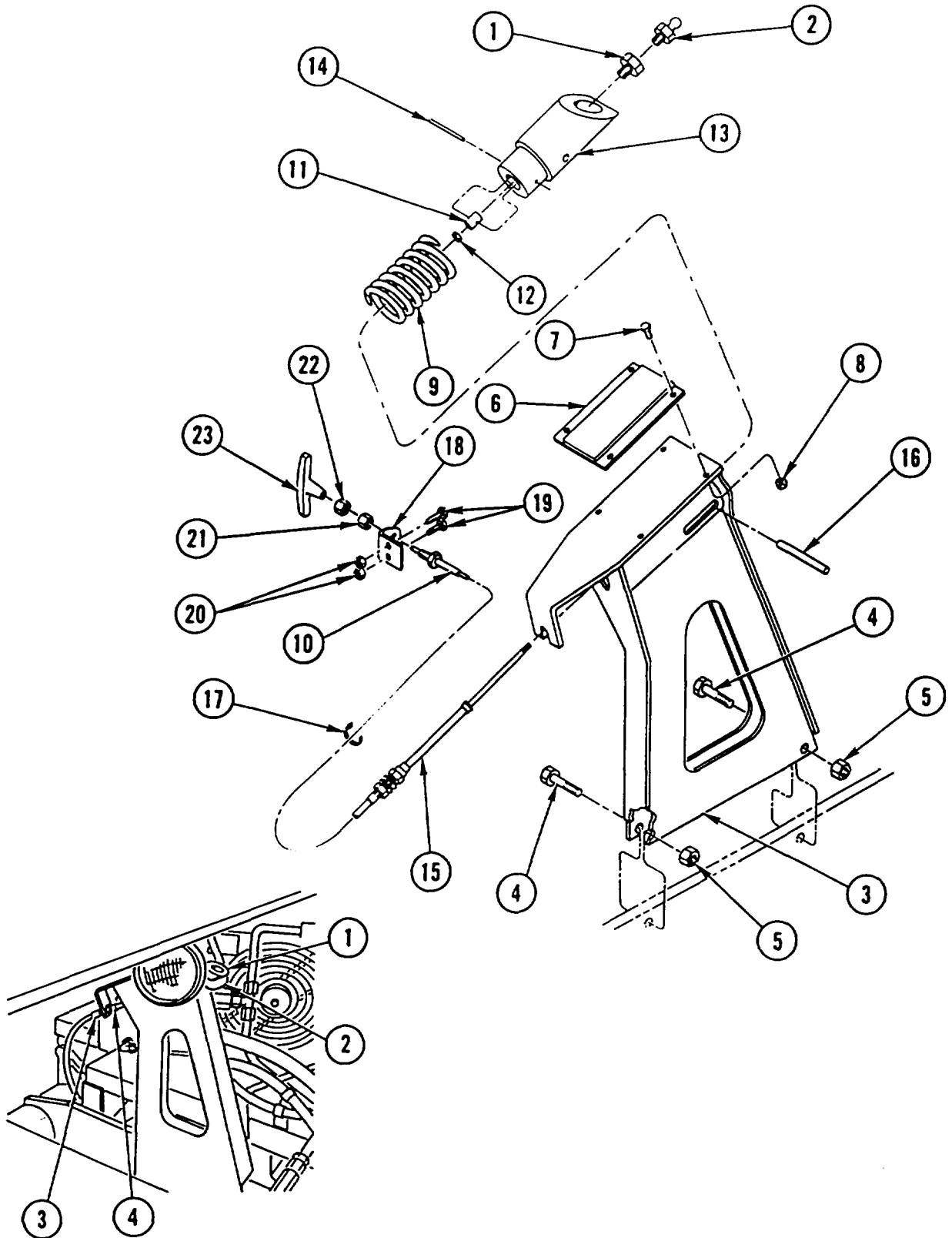

CRANE ROTATION LOCK REPLACEMENT AND ADJUSTMENT

This task covers: a. Removal b. Installation c. Adjustment

INITIAL SETUP

Applicable Configuration:

HMMH

References:

TM 5-2420-224-10

Tools and Special Equipment:

Tool Kit, SC 5180-90-CL-N26

Equipment Condition:

Reference	Condition Description
Page 2-23	Crane in Three-Point Stance

Materials/Parts:

Pin, Cotter(2)

Nut, Lock (2)

Pin, Cotter(2)

Nut, Lock (2)

REMOVAL

1. REMOVE two cotter pins (1), two pins (2), and connecting LINK (3). DISCARD cotter PINS.
2. IF DAMAGED, REMOVE connecting LINK (4) from connecting link (3).
3. REMOVE lock nut (5), control LEVER (6), and lock nut (7). DISCARD lock NUTS.
4. IF DAMAGED, REMOVE KNOB (8) from control lever (6).
5. REMOVE two cotter pins (9), loop CLAMP assembly (10), pin (11), and spring (12). DISCARD cotter PINS.
6. REMOVE lock nut (13), LEVER (14), and lock nut (15). DISCARD lock NUTS.
7. IF DAMAGED, REMOVE lubrication FITTING (16).

INSTALLATION

1. IF REMOVED, INSTALL new lubrication FITTING (16).
2. INSTALL new lock nut (15), LEVER (14), and new lock nut (13).
3. INSTALL spring (12), pin (11), loop CLAMP assembly (10), and two new cotter pins (9).
4. IF REMOVED, INSTALL new KNOB (8) on control lever (6).
5. INSTALL new lock nut (7), control LEVER (6), and new lock nut (5).
6. IF REMOVED, INSTALL new connecting LINK (4) in connecting link (3).
7. INSTALL connecting LINK (3), two pins (2), and two new cotter pins (1).

CRANE ROTATION LOCK REPLACEMENT AND ADJUSTMENT (CONT)

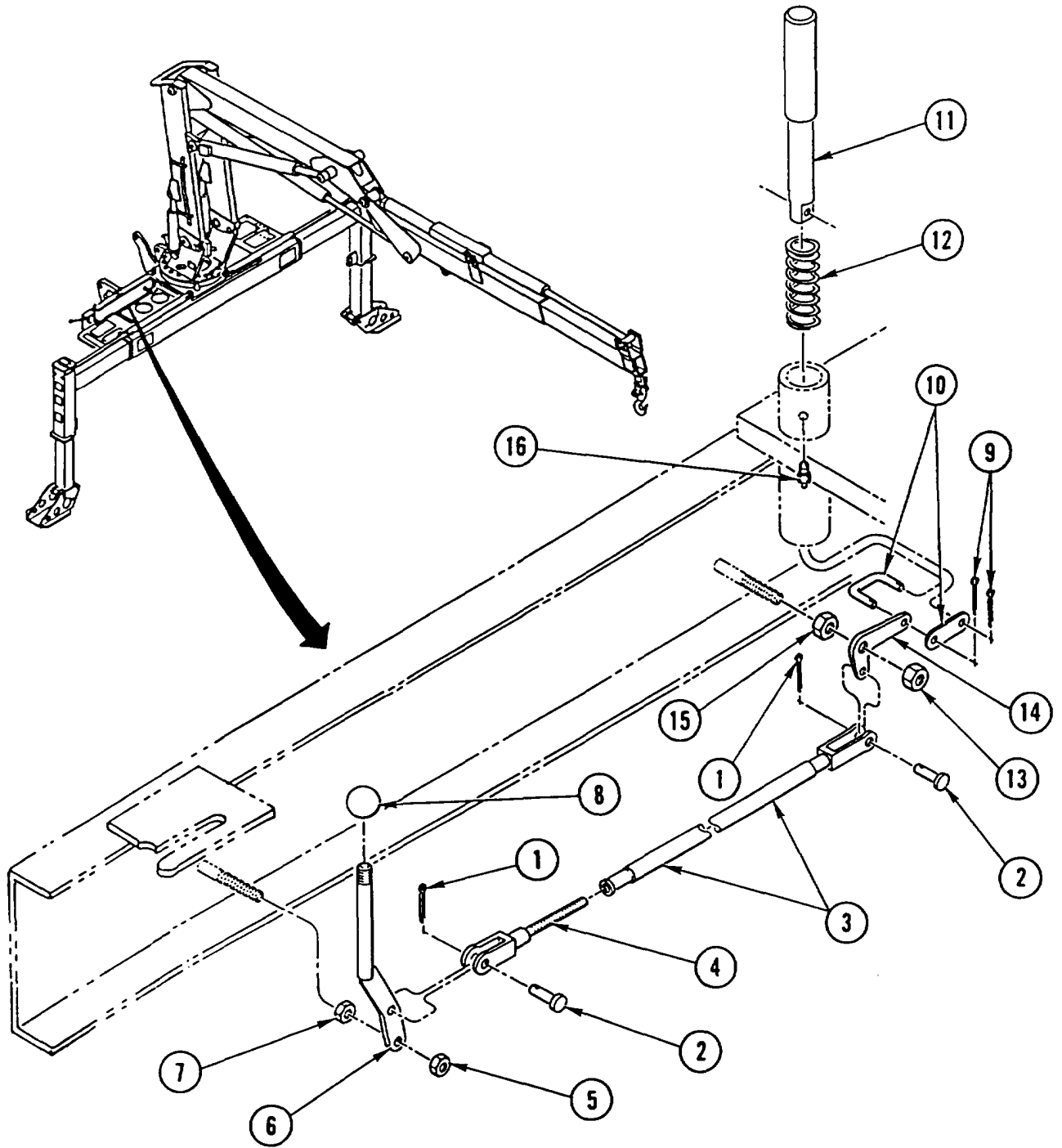

CRANE ROTATION LOCK REPLACEMENT AND ADJUSTMENT (CONT)

ADJUSTMENT

1. Pull control lever (1) into unlock position and make sure pin (2) is completely disengaged from base weldment (3).

NOTE

Perform steps 2 thru 6 only if pin did not completely disengage from base weldment. If completely disengaged, go to step 7.

2. Place control lever (1) in locked position.
3. Remove pin (4) and connecting link (5) from control lever (1).
4. Rotate connecting link (5) to right two turns.
5. Install connecting link (5) and pin (4) on control lever (1).
6. Repeat steps 1 thru 5 until pin (2) becomes completely disengaged from base weldment (3).
7. Place control lever (1) in locked position and make sure pin (2) is completely engaged in base weldment (3).

NOTE

Perform steps 8 thru 11 only if pin did not completely engage in base weldment. If completely engaged, go to step 12.

8. Remove pin (4) and connecting link (5) from control lever (1).
9. Rotate connecting link (5) to left two turns.
10. Install connecting link (5) and pin (4) on control lever (1).
11. Repeat steps 7 thru 10 until pin (2) is completely engaged in base weldment (3).
12. Install new cotter pin (6) in pin (4).

NOTE

Follow-on Maintenance:
Lubricate crane rotation lock (TM 5-2420-224-10).

CRANE ROTATION LOCK REPLACEMENT AND ADJUSTMENT (CONT)

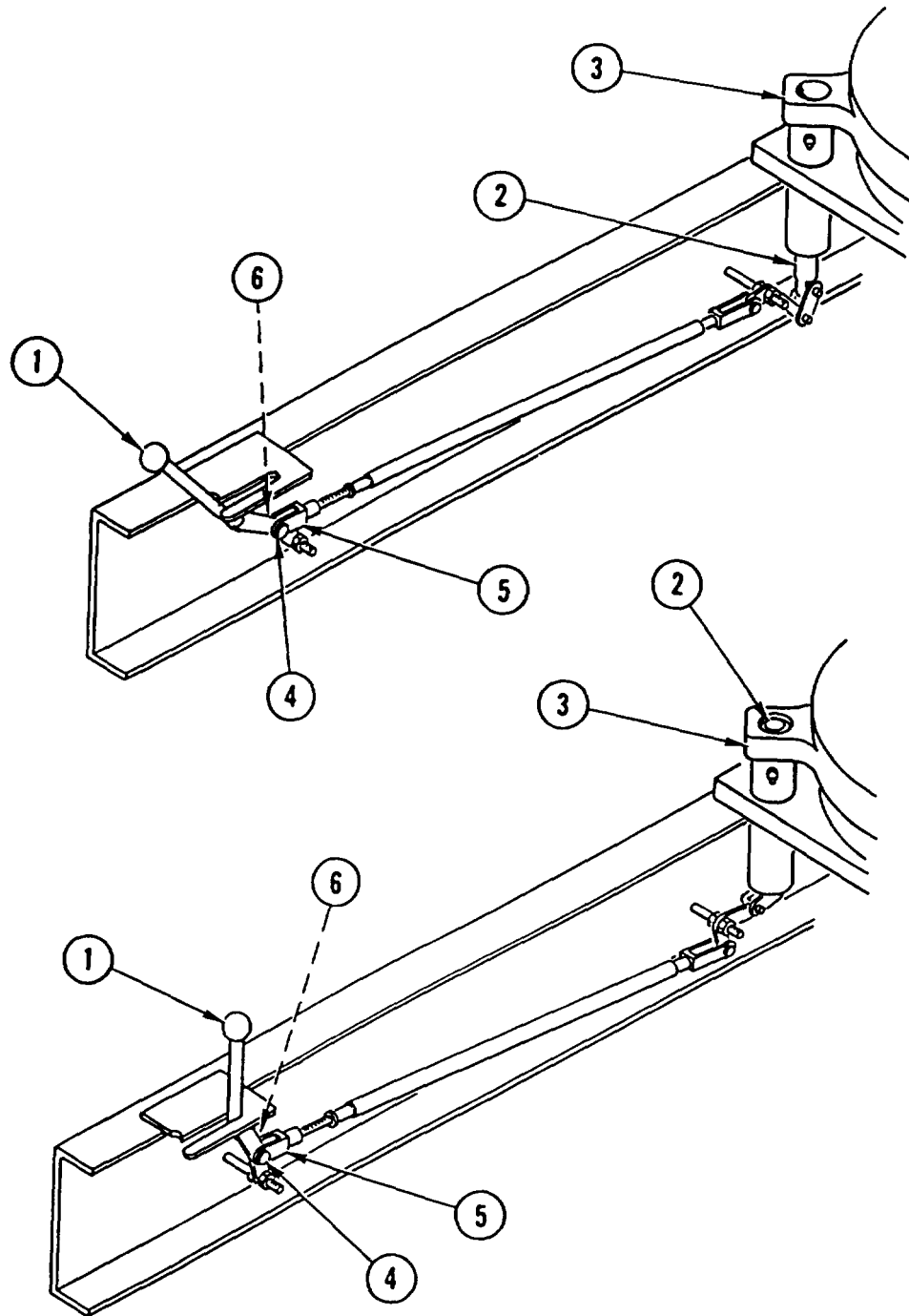

FRONT LOADER REPLACEMENT

This task covers: a. Removal b. Installation

INITIAL SETUP

Applicable Configuration:

SEE

Tools and Special Equipment:

Tool Kit, SC 5180-90-CL-N26
Stand, P/N 41958070 18

Materials/Parts:

Washer, Lock (2)

Rags Appendix C, item 32

Personnel Required: (2)

References:

TM 5-2420-224-10

Equipment Condition:

Reference	Condition Description
TM 5-2420-224-10	Front Loader in Travel Position

General Safety instructions:

W A R N I N G

- SEE should not be operated with front loader removed, except in a maintenance facility. When maintenance is required and front loader is removed, never operate SEE at speeds greater than 5 mph. Tractor stability and handling characteristics are greatly affected with front loader removed. This could cause loss of control and injury to personnel or damage to vehicle.
- High pressure hydraulics [oil under 2450 psi (16,893 kPa)] operate this equipment. Never disconnect any hydraulic line or fitting without first dropping pressure to zero. A high pressure oil stream can pierce body and cause severe injury to personnel.
- Fuel and oil are slippery and can cause falls. To avoid injury, wipe up spilled fuel or oil with rags.

FRONT LOADER REPLACEMENT (CONT)

REMOVAL

1. PARK VEHICLE on level ground and SET parking BRAKE.
2. TURN shutoff VALVES (1 and 2) to ON position.
3. REMOVE two retaining PINS (3) from two travel lock plates (4).
4. START VEHICLE and RAISE FRONT LOADER so travel lock plates (4) release from pins.
5. LOWER FRONT LOADER to ground and SHUT DOWN VEHICLE.

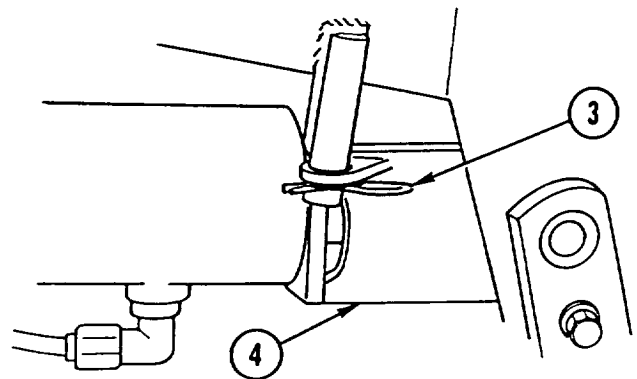
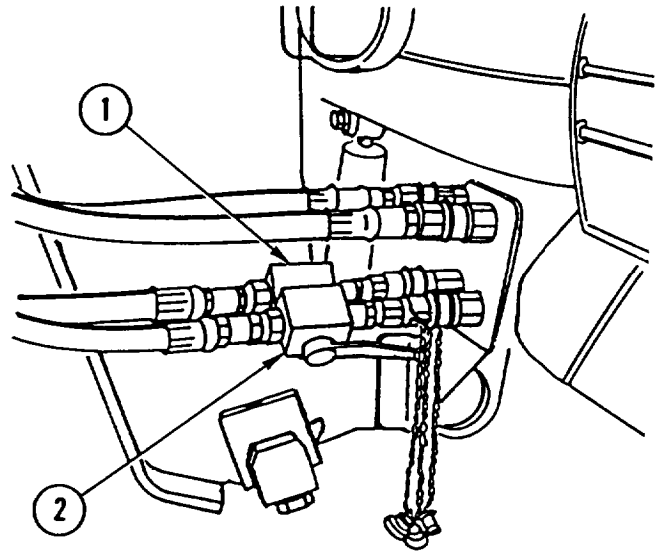

6. LOCK two travel lock PLATES (4) in stowed position by INSTALLING two retaining PINS (3).

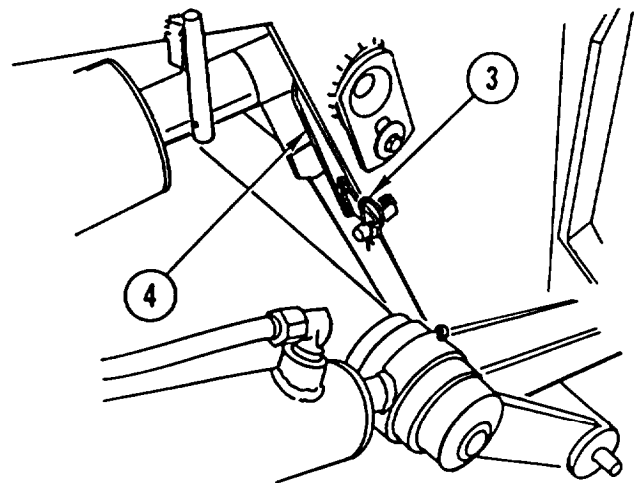

FRONT LOADER REPLACEMENT (CONT)

7. RELIEVE HYDRAULIC PRESSURE (page 2-23).

CAUTION

Run jack down until contact is made with ground to prevent damage to equipment.

8. INSTALL front loader jack STAND.
9. INSTALL retaining PIN.

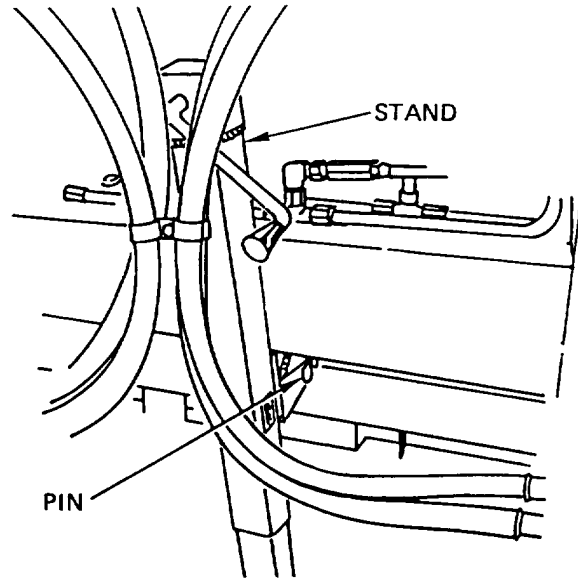

10. REMOVE two BOLTS (5) and two lock washers (6) from front loader mount (7).

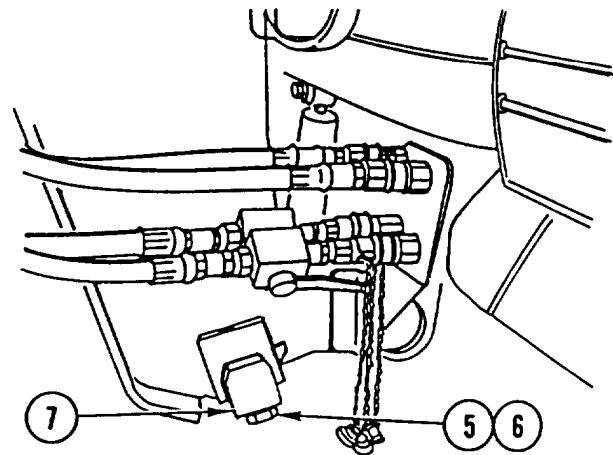

NOTE

If front loader attachment will not separate from mount, use pry bar to aid in separation.

11. JACK UP UNTIL front loader ATTACHMENT (8) IS CLEAR of front loader mount (7).

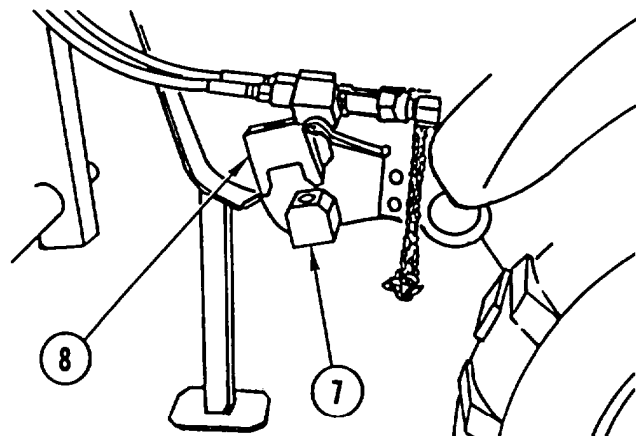

FRONT LOADER REPLACEMENT (CONT)

NOTE

Tag lines prior to disconnecting to aid in connecting.

12. DISCONNECT four hydraulic LINES (9).
13. INSTALL four quick-disconnect CAPS (10).
14. CONNECT male and female hose ENDS together.
15. TURN shutoff VALVES (1 and 2) to OFF position.

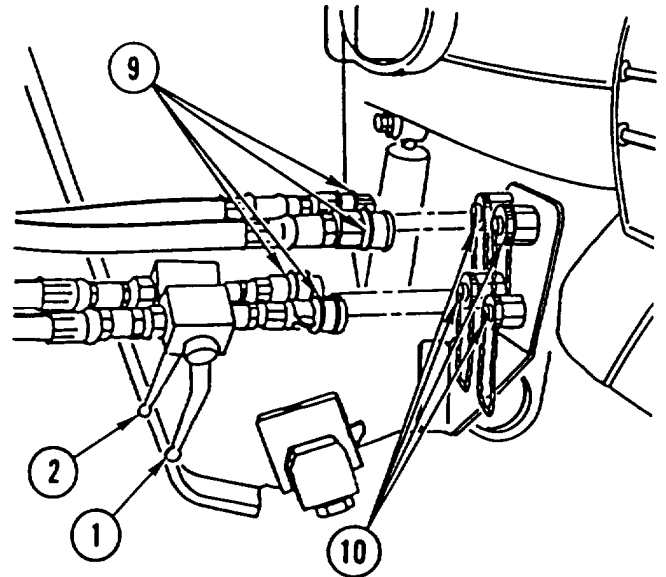

16. INSTALL two BOLTS (5) and two lock washers (6).

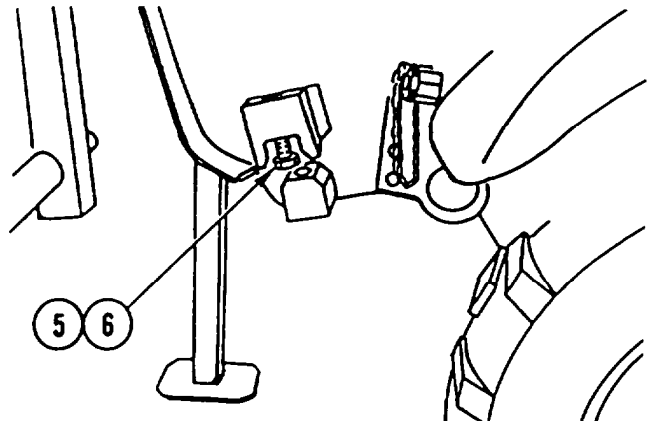

INSTALLATION

1. REMOVE two BOLTS (1) and two lock washers (2). DISCARD lock WASHERS.

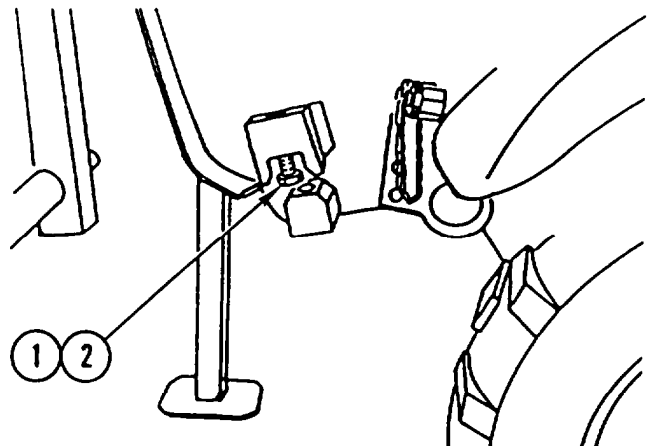

FRONT LOADER REPLACEMENT (CONT)

2. LOWER front loader ATTACHMENT (3) onto front loader mount (4) using jack stand.

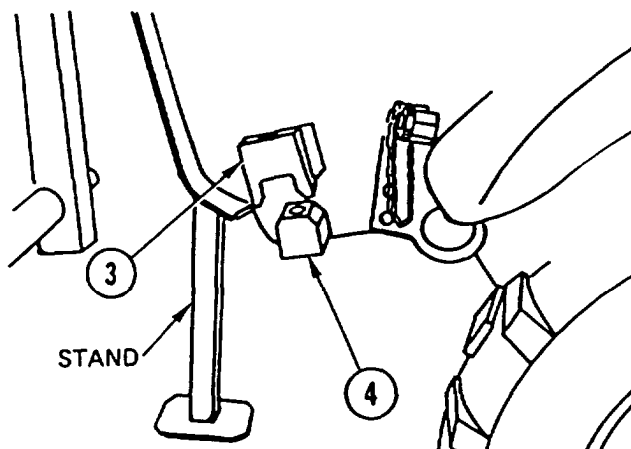

3. INSTALL two BOLTS (1) and two new lock washers (2). TIGHTEN to 750 lb-ft (1016.9 N.m).
4. REMOVE four quick-disconnect CAPS (5).
5. CONNECT four hydraulic LINES (6) and TURN shutoff VALVES (7 and 8) to ON position.

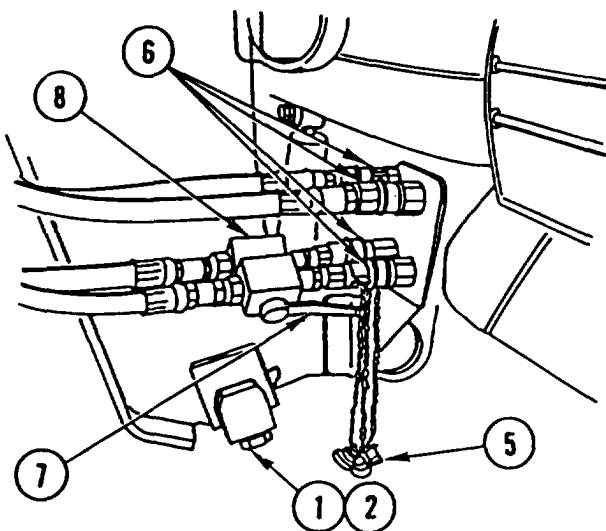

6. START ENGINE and RAISE front LOADER.
7. UNLOCK two travel lock PLATES (9) by REMOVING two retaining PINS (10).

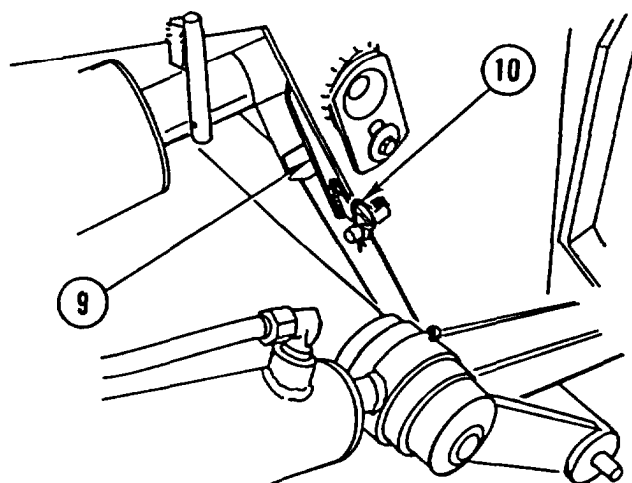

FRONT LOADER REPLACEMENT (CONT)

8. CONNECT two travel lock PLATES (9) to front loader attachment (3) with two retaining pins (10).
9. LOWER FRONT LOADER until it is resting on travel lock plates (9).
10. SHUT DOWN VEHICLE.

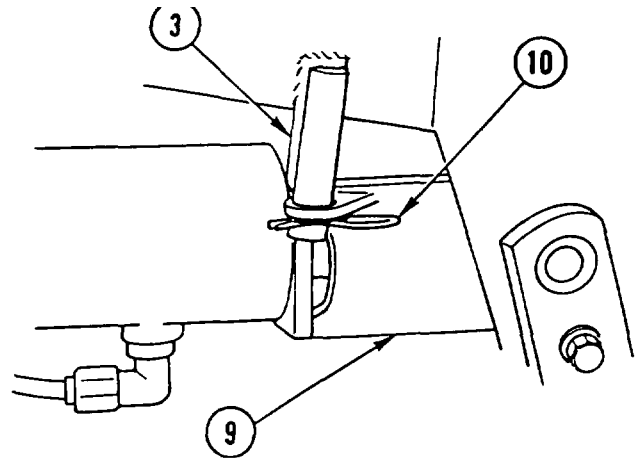

11. TURN shutoff VALVES (7 and 8) to OFF position.

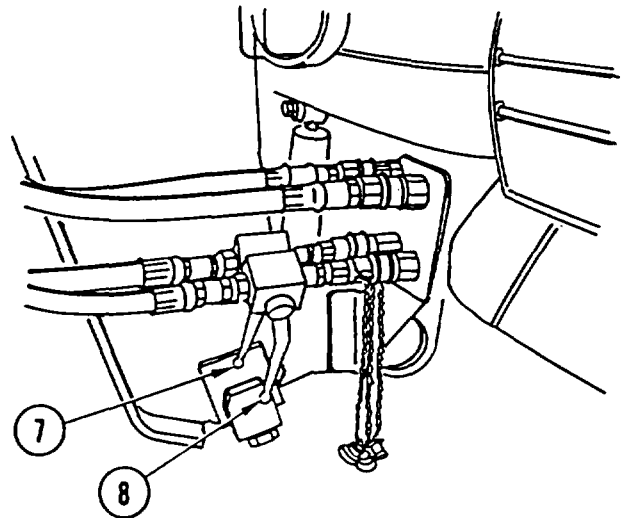

12. REMOVE retaining PIN.
13. REMOVE front loader jack STAND.

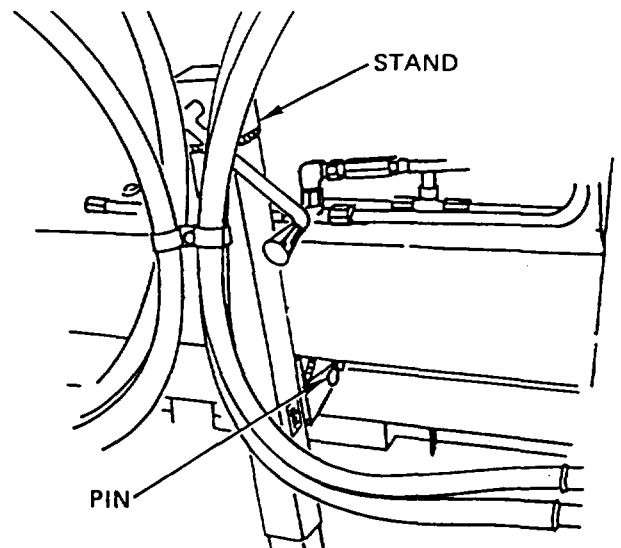

FRONT LOADER MAIN FRAME REPLACEMENT

This task covers: a. Removal b. Installation

INITIAL SETUP

Applicable Configuration:

SEE

Tools and Special Equipment:

Shop Equipment, SC 4910-95-CL-A74
Tool Kit, SC 5180-90-CL-N26

Materials/Parts:

Washer, Lock (2)

Washer, Lock

Washer, Lock (2)

Washer, Lock (2)

Personnel Required: (2)

Equipment Condition:

Reference

Page 4-805

Page 4-656

Page 4-654

Condition Description

Front Loader Lift Arm
Removed

Loader Bucket Rollback
Cylinders Removed

Loader Boom Cylinders
Removed

General Safety Instructions:

WARNING

Front loader main frame weighs 540 pounds (245 kilograms). To avoid personal injury, use a hoist or suitable lifting device when lifting front loader main frame.

REMOVAL

1. REMOVE two capscrews (1), two lock washers (2), and two CLAMPS (3) from main frame (4). DISCARD lock WASHERS.

NOTE

Tag lines prior to removal to aid in installation.

2. REMOVE nut (5), lock washer (6), and two HOSES (7) from main frame (4). DISCARD lock WASHER.
3. REMOVE three capscrews (8), three washers (9), and three CLAMPS (10) from main frame (4).
4. REMOVE two capscrews (11), two lock washers (12), and filter STRAINER (13) from main frame (4). DISCARD lock WASHERS.
5. SET HOSE and TUBE assembly (14) out of the way.
6. REMOVE two bolts (15), two lock washers (16), and main FRAME (4) from vehicle. DISCARD lock WASHERS.

INSTALLATION

1. INSTALL main FRAME (4), two new lock washers (16), and two bolts (15) on vehicle. TIGHTEN BOLTS to 750 lb-ft (1016.9 N.m).

FRONT LOADER MAIN FRAME REPLACEMENT (CONT)

2. POSITION HOSE and TUBE assembly (14) on main frame (4).
3. INSTALL filter STRAINER (13), two new lock washers (12), and two capscrews (11) on main frame (4).
4. INSTALL three CLAMPS (10), three washers (9), and three capscrews (8) on main frame (4).
5. INSTALL two HOSES (7), new lock washer (6), and nut (5) on main frame (4).
6. INSTALL two CLAMPS (3), two new lock washers (2), and two capscrews (1) on main frame (4).

NOTE

Follow-on Maintenance:

Install loader boom cylinders (page 4-654).

Install loader bucket rollback cylinders (page 4-656).

Install front loader lift arm (page 4-805).

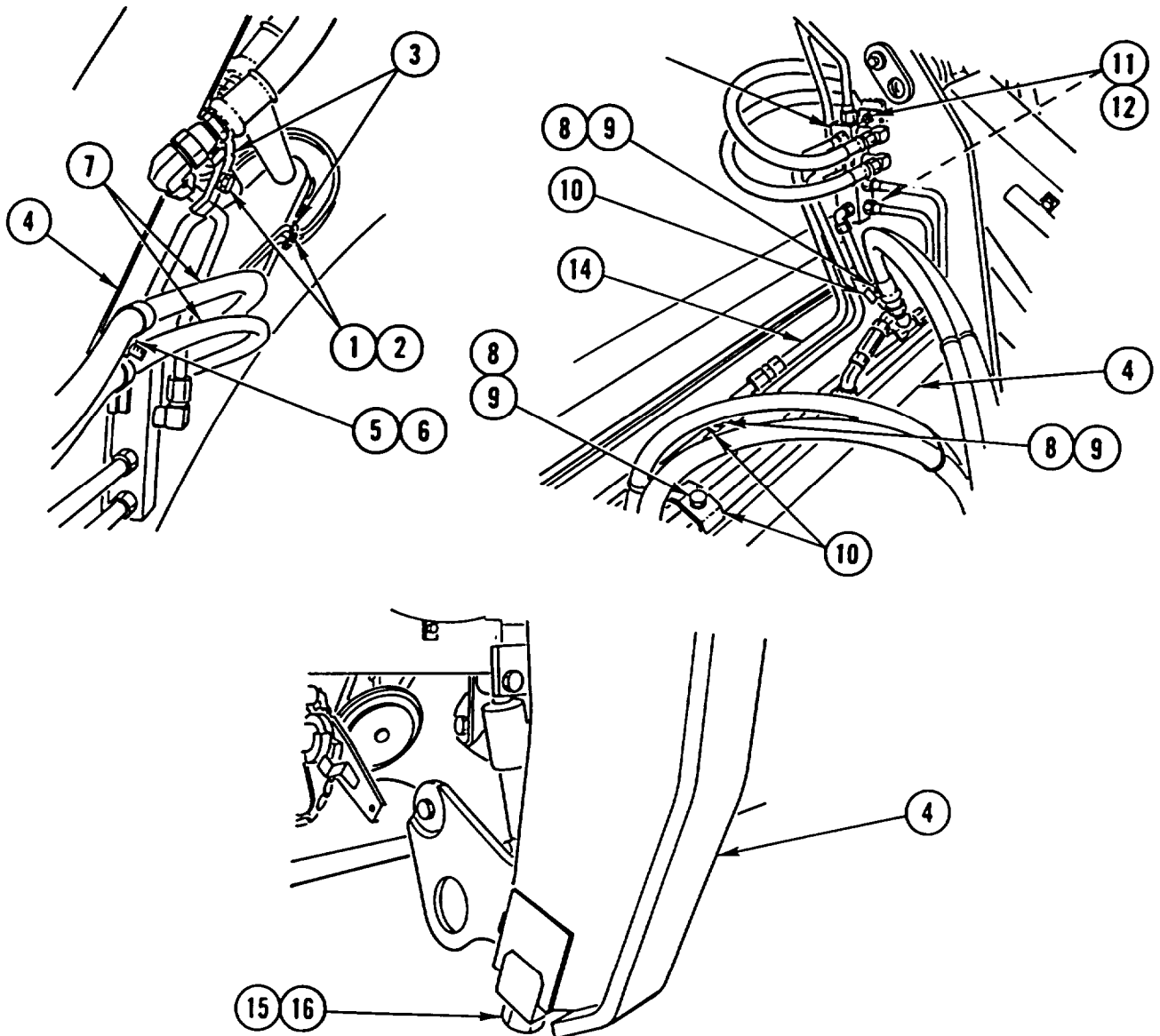

FRONT LOADER BUCKET REPLACEMENT

This task covers: a. Removal b. Installation

INITIAL SETUP

Applicable Configuration:

SEE

Tools and Special Equipment:

Tool Kit, SC 5180-90-CL-N26

Materials/Parts:

Washer, Lock (2)

Personnel Required: (2)

References:

TM 5-2420-224-10

Equipment Condition:

Reference	Condition Description
TM 5-2420-224-10	Front Loader Lowered to Ground
Page 2-23	Hydraulic Pressure Relieved

General Safety Instructions:

WARNING

High pressure hydraulics [oil under 2450 psi (16,893 kPa)] operate this equipment. Never disconnect any hydraulic line or fitting without first dropping pressure to zero. A high pressure oil stream can pierce body and cause severe injury to personnel.

REMOVAL

1. REMOVE nut (1), two washers (2), screw (3), pin (4), and LINK (5).
2. IF DAMAGED, REMOVE lubrication FITTING (6) from link (5).

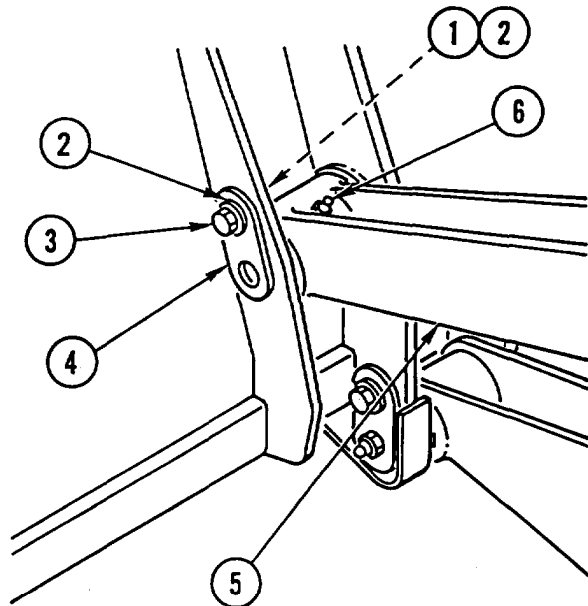

FRONT LOADER BUCKET REPLACEMENT (CONT)

3. REMOVE nut (7), two washers (8), screw (9), pin (10), and DISCONNECT front loader BUCKET (11).
4. IF DAMAGED, REMOVE lubrication FITTING (12) from pin (10).
5. EXTEND bucket CYLINDER (13) until pin (14) clears front loader lift arms (15).
6. REMOVE roll pin (16) and PIN (14) and DISCONNECT CYLINDER (13).
7. REMOVE screw (17), washer (18), lock washer (19), and LINK (20). DISCARD lock WASHER.
8. IF DAMAGED, REMOVE lubrication FITTING (21) from link (20).
9. REPEAT STEPS 1 thru 8 for other side of bucket (11).

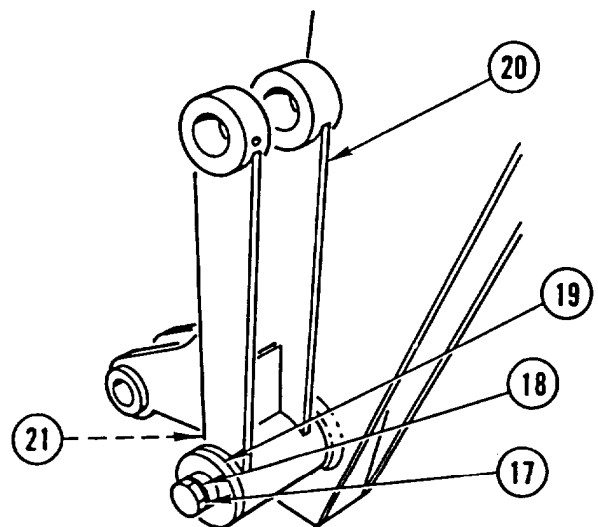
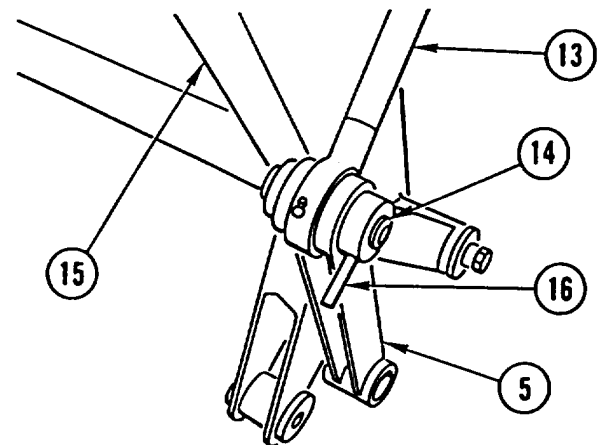
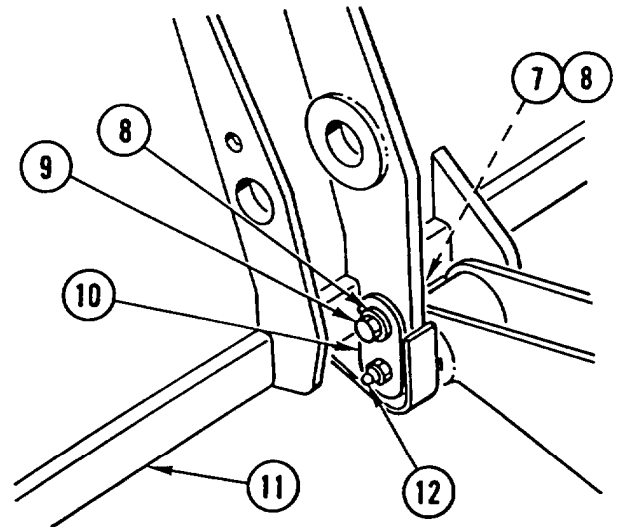

INSTALLATION

1. IF REMOVED, INSTALL new lubrication FITTING (21) in link (20).
2. INSTALL LINK (20), washer (19), new lock washer (18), and screw (17).
3. CONNECT CYLINDER (13), link (5), and link (20) and INSTALL PIN (14) and roll pin (16).
4. IF REMOVED, INSTALL new lubrication FITTING (12) in pin (10).
5. INSTALL front loader BUCKET (11), pin (10), two washers (8), screw (9), and nut (7).
6. IF REMOVED, INSTALL new lubrication FITTING (6) in link (5).
7. INSTALL LINK (5), pin (4), two washers (2), screw (3), and nut (1).
8. REPEAT STEPS 1 thru 7 for other side of bucket (11).

FRONT LOADER BUCKET TOOTH REPLACEMENT

This task covers: a. Removal b. Installation

INITIAL SETUP

Applicable Configuration:

SEE

Material/Parts:

Pin, Grooved

Tools and Special Equipment:

Tool Kit, SC 5180-90-CL-N26

REMOVAL

NOTE

Procedure is the same for all bucket teeth.

1. ROLL BUCKET BACK so that teeth are elevated.
2. REMOVE and DISCARD grooved PIN (1).
3. LIGHTLY TAP TOOTH (2) from rear and REMOVE from bucket.

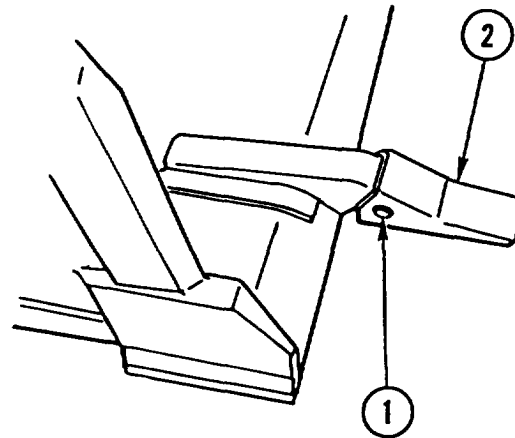

INSTALLATION

NOTE

Procedure is the same for all bucket teeth.

1. INSTALL TOOTH (2) on tooth shank until holes are aligned.
2. INSTALL new grooved PIN (1)

FRONT LOADER LIFT ARM REPLACEMENT

This task covers: a. Removal b. Installation

INITIAL SETUP

Applicable Configuration:

SEE

Tools and Special Equipment:

Shop Equipment, SC 4910-95-CL-A74
Tool Kit, SC 5180-90-CL-N26

Personnel Required: (2)

Materials/Parts:

Washer, Lock (4)

Equipment Condition:

Reference

Page 4-802

Condition Description

Front Loader Bucket
Removed

General Safety Instructions:

WARNING

Front loader lift arm weighs 400 pounds (182 kilograms). To avoid personal injury, use a hoist or suitable lifting device when lifting front loader lift arm.

FRONT LOADER LIFT ARM REPLACEMENT (CONT)

REMOVAL

1. DISCONNECT two CYLINDERS (1 and 2) by REMOVING two bolts (3), two lock washers (4), two washers (5), and two PINS (6). DISCARD lock WASHERS.
2. REMOVE bolt (7), lock washer (8), washer (9), and PIN (10). DISCARD lock WASHER.
3. REPEAT STEP 2 for other side and REMOVE swing ARM (11).
4. IF DAMAGED, REMOVE two lubrication FITTINGS (12).
5. REMOVE four BEARINGS (13).

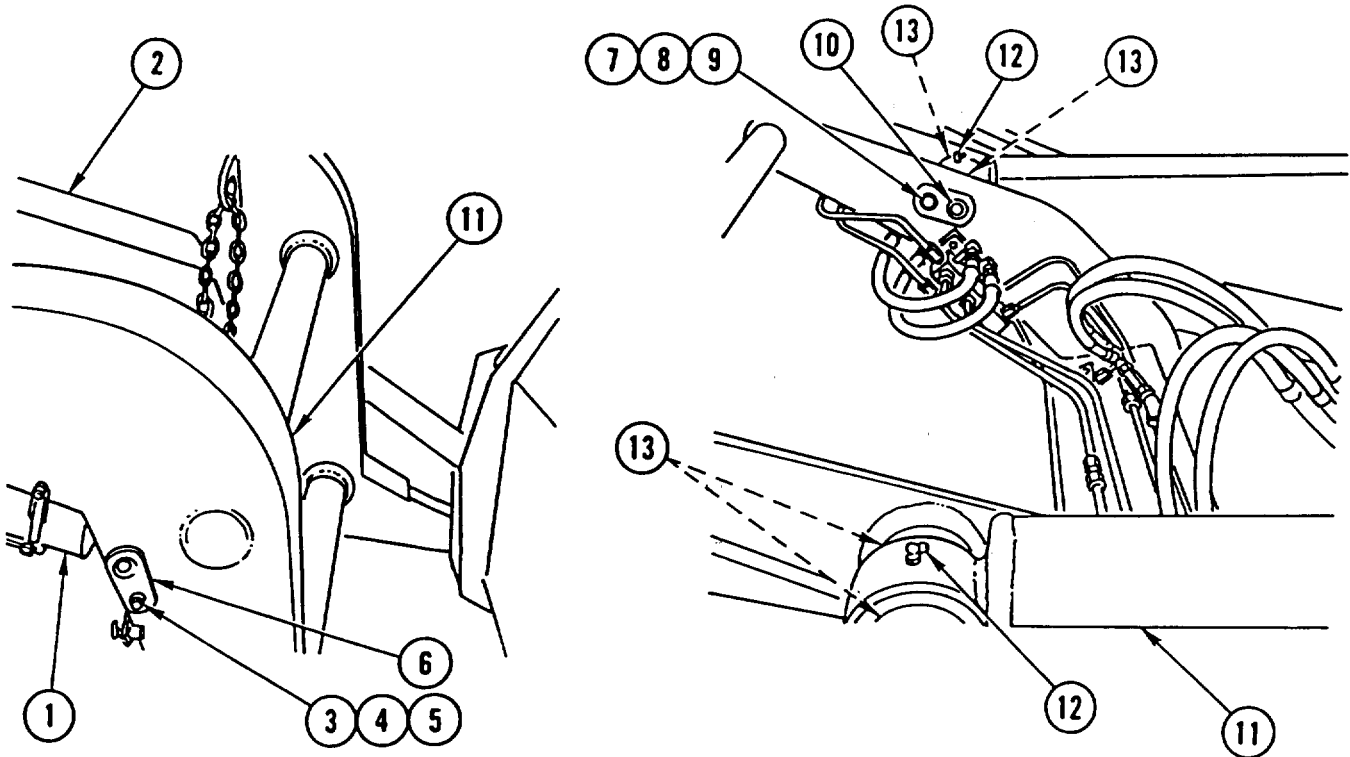

INSTALLATION

1. INSTALL four BEARINGS (13).
2. IF REMOVED, INSTALL two new lubrication FITTINGS (12).
3. INSTALL PIN (10), washer (9), new lock washer (8), and bolt (7) on both sides of swing arm (11). INSTALL swing ARM.
4. CONNECT two CYLINDERS (1 and 2) by INSTALLING two PINS (6), two washers (5), two new lock washers (4), and two bolts (3).

NOTE

Follow-on Maintenance:
Install front loader bucket (page 4-802).

**APPENDIX A
REFERENCES**

PUBLICATION INDEXES

The following index should be consulted frequently for latest changes or revisions and for new publications relating to material covered in this technical manual:

Consolidated Index of Army Publications and Blank Forms DA Pam 25-30

FORMS

The following forms pertain to this material. (Refer to DA Pam 25-30 for index of blank forms.)

DD Form 6, Packaging Improvement Report

SF Form 46, U.S. Government Motor Vehicle Operator's Identification Card

DA Form 91, Operator's Report of Motor Vehicle Accident

SF Form 368, Quality Deficiency Report

DD Form 1397, Processing and Reprocessing Records for Shipment, Storage, and Issue of Vehicles and Spare Engines

DA Form 2028, Recommended Changes to Publications and Blank Forms

DA Form 2028-2, Recommended Changes to Equipment Technical Manuals

DA Form 2404, Equipment Inspection and Maintenance Worksheet

DA Form 2408-9, Equipment Control Record

Refer to DA Pam 738-750, The Army Maintenance Management Systems (TAMMS), for instructions on the use of maintenance forms pertaining to this material.

OTHER PUBLICATIONS

The following publications contain information pertinent to the major item material and associated equipment:

Operating Vehicle

Operator's Manual for SEE/HMMH Wheeled Tractors	TM 5-2420-224-10
Driver Selection and Training (Wheeled Vehicles)	FM 21-300
Army Motor Transport Units and Operation	FM 55-30
Manual for the Wheeled Vehicle Driver	FM 21-305
Prevention of Motor Vehicle Accidents	AR 385-55
Accident Reporting and Records	AR 385-40

OTHER PUBLICATIONS (CONT)

Rigging TM 5-725

Vehicle Recovery Operations. FM 20-22

Maintenance and Repair

Unit Maintenance for SEE/HMMH Wheeled Tractors TM 5-2420-224-20

Unit, Direct Support, and General Support Maintenance
Repair Parts and Special Tools List for SEE/HMMH
Wheeled Tractors TM5-2420-224-24P

Operator's and Organizational Maintenance Manual
Including Repair Parts and Special Tools List for
Decontaminating Apparatus, Portable , TM 3-4230-214-1 2&P

Operator's, Organizational, Direct Support, and
General Support Maintenance Manual for Lead-Acid
Storage Batteries TM 9-6140-200-14

Organizational Care, Maintenance, and Repair of
Pneumatic Tires and inner Tubes TM 9-2610-200-24

Description, Use, Bonding Techniques, and Properties
of Adhesives TB ORD 1032

Materials Used for Cleaning, Preserving, Abrading,
and Cementing Ordnance Material and Related
Materials, Including Chemicals TM 9-247

Metal Body Repair and Related Operations FM 43-2

Painting Instructions for Field Use TM 43-0139

Inspection, Care, and Maintenance of Anti-Friction
Bearings TM 9-214

Use of Antifreeze Solutions and Cleaning Compounds
in Engine Cooling Systems. TB 750-651

Rust Proofing Procedures for Truck, Utility TB 43-0213

Cooling Systems: Tactical Vehicles TM 750-254

Functional Grouping Codes TB 750-93-1

Solder and Soldering TB SIG 222

Operator's Manual for Welding Theory and Application TM 9-237

STE/ICE Technical Manual TM 9-4910-571-12&P

Safety Inspection and Testing of Lifting Devices TB 43-0142

OTHER PUBLICATIONS (CONT)

Cold Weather Operation and Maintenance

Basic Cold Weather Manual	FM 31-70
Northern Operations	FM 31-71
Personnel Heater and Winterization Kit Policy for Tank-Automotive Construction and Material Handling Equipment	SB 9-16
Operation and Maintenance of Ordnance Material in Extreme Cold Weather (0°F to -65°F)	TM 9-207

Decontamination

Chemical, Biological, and Radiological (CBR) Decontamination	TM 3-220
Chemical, Biological, Radiological, and Nuclear Defense . .	FM 21-40
NBC Decontamination	TM 3-5

General

Artificial Respiration	FM 21-11
Principles of Automotive Vehicles	TM 9-8000
Camouflage	FM 5-20
Procedures for Destruction of Tank-Automotive Equipment to Prevent Enemy Use	TM 750-244-6
Administrative Storage of Equipment	TM 740-90-1
Color and Marking of Army Material	TB 43-0209
Preservation, Packaging, and Packing of Military Supplies and Equipment	TM 38-230-1 &TM 38-230-2
Storage Serviceability Standard, Tracked Vehicles, Wheeled Vehicles, and Component Parts	SB 740-98-1
Vehicle, Wheeled, Preparation for Shipment and Limited Storage of	MIL-V-62038D
Warranty	TB 5-2420-224-15
Expendable/Durable Items (Except Medical, Class V, Repair Parts, and Heraldic items)	CTA 50-970
Army Medical Department Expendable/Durable Items	CTA 8-100

OTHER PUBLICATIONS (CONT)

General (Cont)

Nonaeronautical Equipment Army Oil Analysis Program (AOAP) TB 43-0210

APPENDIX B
MAINTENANCE ALLOCATION CHART
FOR
SMALL EMPLACEMENT EXCAVATOR (SEE)
AND
HIGH MOBILITY MATERIAL HANDLER (HMMH)

Section I. INTRODUCTION

GENERAL

This Maintenance Allocation Chart (MAC) designates responsibility for performance of maintenance repair functions at specified maintenance levels.

Section I is a general explanation and definition of terms.

Section II shows the maintenance level responsible and estimated work measurement time for specific functions.

Section III lists common tool sets and the special tools, test, and support equipment required for each maintenance function shown in Section II.

Section IV lists the remarks referenced in Section II.

EXPLANATION OF COLUMNS IN SECTION II

Column 1, Group Number. Column 1 lists group numbers, the purpose of which is to identify components, assemblies, subassemblies, and modules with the next higher assembly.

Column 2, Component/Assembly. Column 2 contains the noun names of components, assemblies, subassemblies, and modules for which maintenance is authorized.

Column 3, Maintenance Function. Column 3 lists the functions to be performed on the item listed in Column 2.

Column 4, Maintenance Level. Column 4 specifies, by the listing of a "work time" figure in the appropriate subcolumn(s), the level of maintenance authorized to perform the function listed in Column 3. This figure represents the active time required to perform that maintenance function at the indicated level of maintenance. If the number or level of the tasks within the listed maintenance function vary at different maintenance levels, appropriate work time figures will be shown for each level. The number of man-hours specified by the work time figure represents the average time required to restore an item (assembly, subassembly, component, module, end item, or system) to a serviceable condition under typical field operating conditions. This time includes preparation time, troubleshooting time, and quality assurance/quality control time in addition to the time required to perform the specific tasks identified for the maintenance functions authorized in the MAC. This figure does not include any time for performance of preliminary tasks listed elsewhere in the MAC; e.g., removal of engine under repair of fuel pump,

when the engine is listed separately in the MAC. The symbol designations for the various maintenance categories remain as follows:

- C — Operator/Crew
- O — Unit Maintenance
- F — Direct Support Maintenance
- H — General Support Maintenance
- D — Depot Maintenance

Column 5, Tools and Equipment. Column 5 specifies, by code, those common tool sets (not individual tools) and special tools, test, and support equipment required to perform the designated functions.

Column 6, Remarks. Column 6 references any amplifying remarks.

MANTENANCE FUNCTIONS DEFINED

Inspect. To closely and critically examine (e.g., sight, sound, or feel) an item to detect errors, flaws, wear, etc., and to determine its condition and serviceability by comparing its physical mechanical/electrical characteristics within established standards.

Test. To verify serviceability and detect incipient failure by measuring the mechanical or electrical characteristics of an item and comparing those characteristics with prescribed standards.

Service. Operations required periodically to keep an item in proper operating condition; i.e., to clean (decontaminate), to preserve, to drain, to paint, or to replenish fuel, lubricants, hydraulic fluids, or compressed air supplies.

Adjust. To maintain, within prescribed limits, by bringing into proper or exact position, or by setting the operating characteristics to specified parameters.

Aline. To adjust specified variable elements of an item to bring about optimum or desired performance,

Calibrate. To determine and cause corrections to be made or to be adjusted on instruments or test measuring and diagnostic equipment used in precision measurement. Consists of comparison of two instruments, one of which is a certified standard of known accuracy, to detect and adjust any discrepancy in the accuracy of the instrument being compared.

Install. The act of emplacing, seating, or fixing into position an item, part, or module (component or assembly) in a manner to allow the proper functioning of an equipment or system.

Replace. The act of substituting a serviceable like type part, subassembly, or module (component or assembly) for an unserviceable counterpart.

Repair. The application of maintenance services (inspect, test, service, adjust, aline, calibrate, or replace) or other maintenance actions (welding, grinding, riveting, straightening, facing, remachining, or resurfacing) to restore serviceability to an item by correcting specific damage, fault, malfunction, or failure in a part, subassembly, module (component or assembly), end item, or system.

Overhaul. That maintenance effort (service/action) necessary to restore an item to a completely serviceable/operational condition as prescribed by maintenance standards (i.e., DMWR) in appropriate technical publications. Overhaul is normally the highest degree of maintenance performed by the Army. Overhaul does not normally return an item to like new condition.

Section II. MAINTENANCE ALLOCATION CHART

(1) GROUP NO.	(2) COMPONENT/ ASSEMBLY	(3) MAINTENANCE FUNCTION	(4) MAINTENANCE LEVEL					(5) TOOLS AND EQUIPMENT	(6) REMARKS
			C	O	F	H	D		
01	ENGINE								
	Engine	Inspect Test Service Replace Repair Overhaul	0.2 0.2	0.2 2.5 1.2	8.8	16.0	36.5	3,4,11 14,15,16,17,20,23	F E K
	Engine Mount	Inspect Replace		0.2	1.4			3,11	
0101	Cylinder Block	Inspect Replace Repair				1.2 15.6 6.9		14,15,16,17 14,15,16,17	
	Cylinder Head	Replace Repair			6.3 6.8			3,11,15,18 3,11,16,17,20,23	
0102	Crankshaft, Main Bearings, and Rear Seals	Inspect Replace				0.5 11.8		3,11,17,23	
	Crankshaft Pulley	Replace				3.2		3,11	E
0103	Flywheel	Inspect Replace Repair			0.4 7.6 8.3			3,11,17,23 3,11,17,23	
	Flywheel End Bell Housing	Replace			6.0			3,11	
0104	Pistons, Rings, Connecting Rods, and Bearings	Inspect Replace				0.5 1.0		3,11	
0105	Valve Cover and Gasket	Inspect Replace		0.1 1.0				5,11	
	Timing Gear Cover, Gears, and Case	Inspect Replace			0.8 3.5			3,11,16,20	E
	Valves	Inspect Adjust Replace		1.4 1.5		1.2		11 3,11,17,23	
	Push Rod Cover	Replace			0.3			3,11	E

(1) GROUP NO.	(2) COMPONENT ASSEMBLY	(3) MAINTENANCE FUNCTION	(4) MAINTENANCE LEVEL					(5) TOOLS AND EQUIPMENT	(6) REMARKS
			C	O	F	H	D		
0106	Rocker Arms. Push Rods, and Tappets	Inspect Replace			1.0 0.3			3,11	
	Camshaft and Bearings	Inspect Replace				0.5 9.8		3,11,17,23	
	Oil Filler Cap	Replace		0.1				11	
	Oil Cooler and Gasket	Inspect Replace	0.1		5.0			3,11	E
	Oil Pan	Inspect Replace Repair		0.1	1.8 0.2			3,11 3,11	
	Oil Pump	Inspect Replace Repair			0.2 1.0 1.0			3,11 3,11	
	Engine Oil Filter	Inspect Replace Repair		0.1	0.1 0.5 1.0			3,11 3,11	
	Engine Oil Filter Element	Replace		0.5				5,11	K
	Engine Oil Hose and Fittings	Inspect Replace		0.1 0.5				11	
	Engine Inlet and Outlet Air Lines	Inspect Replace Repair	0.3	0.5 1.0				11 11	
0108	Exhaust Manifold	Replace			2.4			3,11	E
0121	Air Compressor	Inspect Replace Repair			0.6 1.0 2.5			3,4,11,16,20 3,4,11,16,20	E
02	CLUTCH								
0200	Clutch	Replace			8.9			3,11,16,20	E
0202	Clutch Release Lever and Shaft	Service Adjust Replace		0.1	0.4 2.5			3,11 3,11	E
	Clutch Pedal	Adjust Replace		0.4 0.8				5,11 5,11	

(1) GROUP NO.	(2) COMPONENT ASSEMBLY	(3) MAINTENANCE FUNCTION	(4) MAINTENANCE LEVEL					(5) TOOLS AND EQUIPMENT	(6) REMARKS
			C	O	F	H	D		
			0207	Clutch Hydraulic Reservoir	Inspect Service Replace	0.1 0.1	0.5		
	Clutch Hydraulic Reservoir Lines and Fittings	Replace		2.5				5,11	
	Clutch Slave Cylinder	Adjust Replace		0.3 1.0				11 5,11	E E
	Clutch Master Cylinder	Replace		1.0				5,11	E
03	FUEL SYSTEM								
0301	Fuel Injector Nozzle	Inspect Test Replace Repair			0.4 0.5		0.8 1.0	2,3,24 2,3,11,16,20 2,3,11,16,20	A,E,G
0302	Fuel Injector Lines	Inspect Replace			0.1		3.3	5,11,15,18	B
	Fuel Injection Pump	Adjust Replace Overhaul			2.9 3.6		4.0		
	Fuel Primer Pump	Replace		0.3				5,11	E
0304	Air Cleaner	Inspect Replace	0.2	0.2 0.5				11	
	Air Cleaner Primary Filter Element	Inspect Service Replace		0.1 0.5 0.2					
	Air Cleaner Safety Filter Element	Inspect Replace		0.1 0.2					
	Air Cleaner Ducts	Inspect Replace	0.1	0.1 0.5				11	
0306	Fuel Tank	Inspect Service Replace Repair	0.2 0.1	0.2 1.4		1.0		11 3,9,11	
	Fuel Tank Lines and Fittings	Inspect Replace	0.1	0.1 5.6				5,11	C
	Fuel Cap, Fittings, and Controls	Inspect Replace	0.1	0.5				5,11	

(1) GROUP NO.	(2) COMPONENT ASSEMBLY	(3) MAINTENANCE FUNCTION	(4) MAINTENANCE LEVEL					(5) TOOLS AND EQUIPMENT	(6) REMARKS
			C	O	F	H	D		
0309	Fuel Filter	Service Replace Repair		0.2 0.5 0.5				5,11 5,11	
	Fuel Filter Element	Replace			0.8			5,11	
	Fuel Filter Pre-Sediment Bowl and Filter	Inspect Service Replace		0.1 0.2	0.5			5,11	
0311	Cold Start Aid	Replace		1.0				5,11	
0312	Accelerator Pedal and Linkage	Inspect Service Adjust Replace Repair	0.1	0.1 0.2 1.5 1.0				11 5,11 5,11	E
	Hand Throttle	Inspect Replace	0.1		0.5			11	
	Air Cylinder	Adjust Replace			0.5 1.0			5,11 5,11	
04	EXHAUST SYSTEM								
0401	Muffler	Inspect Replace	0.2	0.2 1.8				5,11	E
	Muffler, Pipes, and Clamps	Inspect Replace	0.2	0.2 1.8				5,11	E
05	COOLING SYSTEM								
0501	Radiator	Inspect Test Service Replace Repair	0.2 0.2	0.2 0.5 1.0 1.6	2.0			1,15,18 1,5,11 3,5,7,11	H H,J
	Coolant Hoses and Clamps	Inspect Replace	0.1	0.1 1.0				5,11	E
	Coolant Expansion Tank	Inspect Test Service Replace	0.2 0.2	0.5 1.3				15,18 5,11	
0503	Coolant Thermostat	Replace		0.8				5,11	

(1) GROUP NO.	(2) COMPONENT/ ASSEMBLY	(3) MAINTENANCE FUNCTION	(4) MAINTENANCE LEVEL					(5) TOOLS AND EQUIPMENT	(6) REMARKS
			C	O	F	H	D		
0504	Water Manifold and Gasket	Inspect Replace	0.2	1.0				5,11	E
	Water Pump	Inspect		0.1	0.4			11	
		Replace Repair			2.5 1.8			3,11	
0505	Fan Impeller	Inspect Replace	0.1	1.7				11	
06	FAN BELT	Inspect	0.2	0.2				11	
		Adjust Replace		1.0 0.9				11	
ELECTRICAL SYSTEM									
0601	Alternator and Alternator Bracket	Inspect Test Replace Repair		0.2 0.4 1.3	2.3			11 3,11	E
0602	Bearings	Replace			0.3			3,11	
	Regulator	Replace			0.4			3,11	E
	Alternator Pulley	Replace		0.2				11	
0603	Starter	Inspect Test Replace Repair		0.2 0.4 1.8	1.9			2 11 2,8,11	E
0606	Brushes	Replace			0.6			3,11	
	Solenoid	Test		0.2				13	
		Replace			0.5			11	
0607	Polarity Breaker	Replace		1.3				11	E
0608	Instrument Panel Gages, Switches, Lights, and Relays	Inspect Test Replace	0.2	0.2 0.5 1.3				11	
	Hydraulic Suspension Lockout Controls	Replace		1.5				11	
0608	Auxiliary Light Control Switch	Replace		0.3				11	

(1) GROUP NO.	(2) COMPONENT/ ASSEMBLY	(3) MAINTENANCE FUNCTION	(4) MAINTENANCE LEVEL					(5) TOOLS AND EQUIPMENT	(6) REMARKS
			C	O	F	H	D		
0609	Bucket and Auxiliary Throttle Switches	Inspect Replace	0.1	1.0				11	D
	Throttle Control Switch	Inspect Replace	0.1	0.8				11	
	Auxiliary Throttle Switch	Replace		0.8				11	
	Tool and Work Light Switches	Replace		0.8				11	
	Main Disconnect Switch	Replace		1.0				11	
	Fuse Holder	Inspect Replace	0.1	1.6				11	
	Fuse	Inspect Replace	0.1	0.1					
	Headlight	Inspect Test Replace	0.1	0.5 0.5				11	
	Auxiliary Headlight	Inspect Adjust Replace	0.1	1.0 0.5				11 11	
	Front Blackout Light	Inspect Test Replace Repair	0.1	0.5 0.5 0.8				11 11	
	Front Composite Light	Inspect Replace Repair	0.1	1.0 1.5				11 11	
	Work Lights	Inspect Test Replace Repair	0.1	0.5 0.5 0.8				11 11	
	Crane Mast Floodlight	Inspect Replace Repair	0.1	0.3 0.5				11 11	
	Rear Composite Stoplight/Taillight	Inspect Test Replace Repair	0.1	0.5 0.5 0.8				11 11	

(1) GROUP NO.	(2) COMPONENT/ ASSEMBLY	(3) MAINTENANCE FUNCTION	(4) MAINTENANCE LEVEL					(5) TOOLS AND EQUIPMENT	(6) REMARKS
			C	O	F	H	D		
0610	Dome Light	Inspect Replace	0.1	0.3				11	
	Brake Light Switch	Replace		0.5				11	
	Turn Signal Flasher Relay	Replace		0.2				11	
	Starter Lockout/Intermediate Speed Shift Sending Unit	Replace		0.5				11	
	Oil Pressure Sender	Replace		0.5				11	
	Water Temperature Gage	Replace		1.5				11	
	Fuel Level Gage	Replace		1.5				11	
	Air Cleaner Restrictor Indicator Switch	Replace		0.2				11	
	Power Take-Off Indicator Switch	Replace		0.5				11	E
	Differential Lock Indicator Switch	Replace		0.5				11	
	Backup Alarm Switch	Replace		1.2				11	E
	Intermediate Speed Shift and Indicator Switch	Replace		1.2				11	E
	Parking Brake Switch	Replace		0.5				11	
	STE/ICE-R Resistor	Test Replace		0.5 0.5				11	E
0611	STE/ICE-R Fuel Pressure Switch	Test Replace		0.5 4.0				5,11	
	STE/ICE-R Shunt	Replace		0.5				11	
	Backup Alarm	Test Replace		0.2 0.3				11	

(1) GROUP NO.	(2) COMPONENT/ ASSEMBLY	(3) MAINTENANCE FUNCTION	(4) MAINTENANCE LEVEL					(5) TOOLS AND EQUIPMENT	(6) REMARKS
			C	O	F	H	D		
0612	Low Oil Pressure and High Water Temperature Alarm	Inspect Replace	0.1	0.3				11	
	Horn, Low Beam/High Beam Switch	Replace		2.5				11	
	Horn	Inspect Replace	0.1	0.4				11	
	Batteries	Inspect Test Service Replace Repair	0.1	0.3 0.5 0.8	1.6			5,11 3,6,11	I
	Cables	Inspect Service Replace	0.2	0.2 0.3 1.6				11	
	Battery Box	Inspect Replace Repair	0.2	0.2 0.5 1.0				11 11	
0613	Wiring Harnesses, Leads, and Cables	Test Replace Repair		2.0 0.5	24.0 3.5			3,11 8	
	Front Disc Brake Pad Indicator Wiring Harness	Test Replace Repair		0.3 1.5 1.0				11 8	
	Slave Receptacle	Replace Repair		0.5 0.5				11 11	
	Trailer Connection	Test Replace Repair		0.5 0.5 0.8				11 11	
0615	Suppressor Filter	Replace		1.5				11	E
07	TRANSMISSION								
0700	Transmission	Inspect Service Replace Repair Overhaul	0.5 0.2	0.5 0.8	13.3	14.8	34.2	3,4,11 3,11,16,17,20,23	E

(1) GROUP NO.	(2) COMPONENT/ ASSEMBLY	(3) MAINTENANCE FUNCTION	(4) MAINTENANCE LEVEL					(5) TOOLS AND EQUIPMENT	(6) REMARKS
			C	O	F	H	D		
	Transmission Access Cover	Adjust Replace Repair			0.5 1.5 2.3			3,11,17,23 11 3,11,17,23	
0701	Power Take-Off	Inspect Replace Repair	0.2		0.6 3.2			3,11 3,11	E E
0704	Transmission Top Cover	Replace Repair				1.8 2.5		3,11 3,11,17,23	L L
	Air Shift Solenoid Valve	Replace			1.5			11	E
	Air Shift Valve	Replace			1.5			11	E
	Transmission Shift Lines	Replace			2.0			11	E
0705	Transmission Shift Controls	Inspect Replace			0.5 1.0	1.0		3,11	
	Transmission Mount	Replace			1.0			3,11	
	Power Take-Off Control Linkage	Adjust Service Replace		0.1	1.5 1.7			3,11	E
	All Wheel Drive Selector Valve	Inspect Replace		0.2 1.0				11	E
	All Wheel Drive Pressure Regulator	Replace		1.0				11	E
	All Wheel Drive Control Cylinder	Adjust Replace		0.4 1.0				11	E
09	PROPELLER SHAFTS								
0900	Propeller Shafts	Inspect Replace	0.2		3.9			3,11	
	U-Joints	Inspect Replace	0.1		0.4 2.0			3,11	

(1) GROUP NO.	(2) COMPONENT/ ASSEMBLY	(3) MAINTENANCE FUNCTION	(4) MAINTENANCE LEVEL					(5) TOOLS AND EQUIPMENT	(6) REMARKS
			C	O	F	H	D		
10	FRONT AXLE								
1000	Front Axle	Inspect Service Replace Repair	0.4	0.4 0.8	5.1		20.5	3,11,15,18 3,4,11,15,16,17,18,23	
	Axle Vent Hoses	Replace		0.5				5,11,15,18	
	Thrust Arms	Replace			1.0			3,11	
1002	Front Axle Differential	Replace					15.0	3,4,11,15,16,17,18,23	
1003	Final Drive Outer Seal	Replace		1.5				5,11,15,18	
	Final Drive	Inspect Replace Repair			0.2 1.5 2.5			3,11,16,17,20,23 3,4,11,15,16,17,18,20,23	
1004	Steering Knuckle	Inspect Replace Repair			0.3 0.8 2.5			3,11,16,17,20,23 3,4,11,15,16,17,18,20,23	
11	REAR AXLE								
1100	Rear Axle Assembly	Inspect Service Replace Repair	0.4	0.4 0.8	8.0		17.3	3,11,15,18 3,4,11,15,16,17,18,23	
	Axle Vent Hoses	Replace		1.0				5,11,15,18	
	Thrust Arms	Replace			1.0			3,11	
1102	Rear Axle Differential	Replace					12.0	3,4,11,15,16,17,18,23	
1103	Final Drive	Inspect Replace			0.2 3.0			3,11,17,23	
	Final Drive Outer Seal	Replace		1.5				5,11,15,18	

(1) GROUP NO.	(2) COMPONENT/ ASSEMBLY	(3) MAINTENANCE FUNCTION	(4) MAINTENANCE LEVEL					(5) TOOLS AND EQUIPMENT	(6) REMARKS
			C	O	F	H	D		
12	BRAKES								
1201	Parking Brake Controls	Inspect Service Adjust Replace	0.1	0.1 0.1 1.2 2.0				11 5,11	E
1202	Brake Disc and Hub	Inspect Replace Repair		0.2 6.0	1.5			5,11,15,18 3	
	Disc Brake Pads	Inspect Replace		0.5 1.0				5,11,15,18	
	Brake Caliper	Replace Repair		1.0	1.8			5,11,15,18 3,11,16,17,20,23	
1204	Master Cylinder	Replace Repair		1.2	1.3			5,11,15,18 3,11	
	Hydraulic Lines and Fittings	Inspect Replace	0.1	0.1 1.7				5,11,15,18	
	Brake Pressure Regulator (ALB Valve)	Adjust Replace Repair			1.0 2.5 2.5			3,11,23 3,11 3,11	
	Brake Fluid Reservoir	Inspect Service Replace	0.1 0.1	2.0				5,11	
1206	Brake Pedal	Adjust Replace		0.5 1.0				11 11	
1208	Air Pressure Tanks	Inspect Service Replace	0.1 0.1	2.0				5,11	
	Overflow Valves and Fittings	Replace		1.5				5,11	
	Brake Booster	Replace Repair		1.2	1.0			11 11	
	Air Lines and Fittings	Inspect Replace		0.5 2.0				11	
	Antifreeze Reservoir	Replace		0.5				5,11,15,18	

(1) GROUP NO.	(2) COMPONENT/ ASSEMBLY	(3) MAINTENANCE FUNCTION	(4) MAINTENANCE LEVEL					(5) TOOLS AND EQUIPMENT	(6) REMARKS
			C	O	F	H	D		
1211	Fluid Regulating Valve	Replace Repair		0.5	1.0			5,11 3,11	E
	Antifreeze Device	Inspect Replace Repair	0.2	1.2	1.0			5,11,15,18 3,11	
	Tandem Valve	Inspect Replace Repair	0.1	1.0	0.8			11 3,11	
	Trailer Hand Brake Valve	Replace		0.5				11	
	Front Trailer Coupling	Replace		0.5				11	
	Trailer Air Supply Valve	Replace		1.5				11	
	Tractor Protection Valve	Replace		1.0				5,11	
	Protection/Relay Valve	Replace		1.0				11	
13	Lines and Fittings	Inspect Replace	0.1	2.0				11	WHEELS
	1311	Wheel Assembly	Inspect Replace	0.2 0.2	0.5			5	
1313	Tires	Inspect Service	0.5 0.2	0.5				5	M
		Replace Repair		1.0	0.8	1.0		3,10	
14	STEERING								
1401	Tie Rod	Inspect Adjust Replace Repair	0.2	0.2 1.0 1.3 0.5				11 5,11,15,18 5,11	
		Replace		0.4				5,11	
	Steering Wheel	Replace		0.4				5,11	
	Drag Links	Inspect Adjust Replace	0.2	0.2 0.7 0.8				5,11 5,11,15,18	

(1) GROUP NO.	(2) COMPONENT/ ASSEMBLY	(3) MAINTENANCE FUNCTION	(4) MAINTENANCE LEVEL					(5) TOOLS AND EQUIPMENT	(6) REMARKS
			C	O	F	H	D		
1407	Steering Arm	Inspect Replace	0.1	1.5				5,11	
	Pitman Arm	Inspect Replace	0.1		1.5			3,11,16,20	
	Steering Upper Shaft Bearing	Replace		2.0				5,11	
	Power Steering Gear	Inspect Adjust Replace Overhaul		0.2 1.7	10.2		5.0	11 3,11,15,18	E E
1410	Power Steering Pump	Inspect Replace Overhaul		0.2	2.9		1.5	3,11	E E
1411	Steering Pump Belt	Inspect	0.1	0.1				11	
		Adjust Replace		0.2 0.7				11	
1413	Power Steering Lines and Fittings	Inspect Replace		0.2 1.0				5,11	E
1413	Power Steering Filter Element	Replace		0.5				11	E
15	Power Steering Tank (Reservoir)	Inspect	0.1	0.1					
		Service	0.2	0.5					
		Replace		1.5				5,11	E
15	FRAMES AND TOWING ATTACHMENTS								
1501	Rear Frame Section and Subframe	Inspect	0.5	0.5					
		Replace Repair			8.0 2.0			3,11 3,11	
1503	Forklift Mounting Bracket	Replace			1.5			3,11	
	Platforms	Inspect Replace			0.2 5.0			3,11	
	Pintle Assembly	Inspect Service Replace	0.1	0.1 0.1 0.5				5,11	

(1) GROUP NO.	(2) COMPONENT/ ASSEMBLY	(3) MAINTENANCE FUNCTION	(4) MAINTENANCE LEVEL					(5) TOOLS AND EQUIPMENT	(6) REMARKS
			C	O	F	H	D		
1504	Spare Tire Mount	Inspect Replace	0.1	0.3				11	
16	SPRINGS AND SHOCK ABSORBERS								
1601	Front and Rear Springs	Inspect Replace	0.2	0.2	0.2 9.0			3,11	
1604	Front Shock Absorbers	Inspect Replace	0.2	3.0				5,11	E
	Rear Shock Absorbers	Inspect Replace	0.2	3.0				5,11	E
1605	Torsion Bars and Control Arms	Replace		2.5				5,11	E
18	BODY, CAB, AND HOOD								
1801	Front Plate	Replace		1.0				5,11	
	Canopy (FOPS)	Inspect Replace	0.2	0.5				5,11	
	Roll-Over Protection (ROPS)	Inspect Replace	0.2		0.4 30.0			3,11	
	Cab	Inspect Replace Repair	0.2		1.0 4.0			3,11 3,9,11,12	
	Outside Engine Hood	Replace		0.1					
	Inside Engine Hood	Replace		0.3					
	Backhoe Control Tower	Replace		2.0				11	
	Cab Door	Service Replace Repair		0.1 1.5 1.0				11 11	
	Cab Door Seal	Inspect Replace		0.1 1.0				11	

(1) GROUP NO.	(2) COMPONENT/ ASSEMBLY	(3) MAINTENANCE FUNCTION	(4) MAINTENANCE LEVEL					(5) TOOLS AND EQUIPMENT	(6) REMARKS
			C	O	F	H	D		
1802	Windshield	Inspect Replace	0.1	0.1	2.0			11	
	Rear Windows	Inspect Replace	0.1		1.5			11	
	Front Fender and Splash Guard	Inspect Replace		0.1 0.5				11	
	Rear Splash Guard	Replace		0.5				11	
	Cab Door Side Windows	Inspect Replace		0.1 1.0				11	
1804	Cab Drain Plug	Replace		0.2				11	
1805	Cab Shock Absorbers and Mountings	Replace		6.0				5,11	
1806	Operator Seat and Framework	Inspect	0.2					11	
		Replace		1.5				11	
	Backhoe Seat	Repair		1.0				11	
		Inspect	0.2					11	
	Passenger Seat and Framework	Replace		1.5				11	
		Repair		1.5				11	
	Seat Belt	Inspect Replace	0.2					11	
	Seat Belt	Inspect Replace	0.2		0.5			11	
Cab Floor Linings	Replace		0.5				11		
Sun Visor, Clothes Hook, and Grip Handles	Replace		0.5				11		
1808	Hose Reel Assembly	Inspect	0.2					5,11	
		Replace		0.8				5,11	
1808	Hydraulic Accessory Box	Repair		1.0				5,11	
		Inspect	0.1					11	
		Service		0.1				11	
1808	Hydraulic Accessory Box	Replace		1.0				11	
		Repair		1.0				11	

(1) GROUP NO.	(2) COMPONENT/ ASSEMBLY	(3) MAINTENANCE FUNCTION	(4) MAINTENANCE LEVEL					(5) TOOLS AND EQUIPMENT	(6) REMARKS
			C	O	F	H	D		
22	BODY, CHASSIS, AND ACCESSORY ITEMS								
2202	Interior and Exterior Rear View Mirrors	Inspect Replace Repair	0.1	0.5 0.5				11 11	
	Windshield Wiper/Washer Motor	Inspect Replace	0.2	2.0				11	
	Windshield Wiper/Washer Motor Linkage	Replace		1.5				5,11	
	Windshield Wiper	Inspect Replace	0.1	0.2				11	
	Windshield Washer Reservoir	Inspect Service Replace	0.1 0.2	1.0				11	
	Windshield Washer Pump	Replace		1.0				11	
	Defroster and Air Tubes	Inspect Replace	0.2	2.0				11	
	Cab Heater	Inspect Replace Repair	0.2	2.0	2.0			11 3,11	
2210	Data Plates	Inspect Replace		0.2 0.5				5,11	
24	HYDRAULIC AND FLUID SYSTEM								
2401	Front Hydraulic Pump	Inspect Replace Repair		0.1 1.5	2.0			5,11 3,11,13	
	Rear Hydraulic Pump	Inspect Replace Repair		0.1 3.5	2.0			5,11 3,11,13	E
	Front Hydraulic Pump Belt	Inspect Adjust Replace	0.2	0.2 1.0 1.5				5,11 5,11	

(1) GROUP NO.	(2) COMPONENT/ ASSEMBLY	(3) MAINTENANCE FUNCTION	(4) MAINTENANCE LEVEL					(5) TOOLS AND EQUIPMENT	(6) REMARKS
			C	O	F	H	D		
2402	Hydraulic Suspension Lockout Filter	Inspect Service Replace		0.1 0.2 1.0				5,11	
	Hydraulic Suspension Lockout Motor and Pump	Inspect Service Replace Repair	0.2	0.3 1.0	1.0			5,11 3,11	
	Hydraulic Suspension Lockout Accumulator	Replace		0.3				11	
	Crane Hydraulic Motor	Replace Repair		0.5	1.5			5,11 3,11,23	
	Tilt and Latch Control Valve Assembly	Inspect Adjust Replace Repair	0.2	0.2	1.5 4.5 3.0			3,11,13 3,11,13 3,11,13	
	Lines and Fittings	Inspect Replace		0.3 0.5				11	
	Crane Valve Bank	Inspect Replace Repair	0.2	0.2	4.5 3.0			3,11,13 3,11,13	
	Crane Valve Bank Relief Valve	Inspect Replace		0.2	2.0			3,11	
	Front Loader/Forklift Control Valve	Inspect Adjust Replace Repair	0.2	0.2	1.5 1.6 1.0			3,11,13 3,11,13 3,11,13	
	Backhoe Stabilizer Control Valve	Inspect Replace Repair	0.2	0.2	3.5 1.0			3,11 3,11,13	
	Backhoe Control Valve	Inspect Test Adjust Replace Repair	0.1	0.1 0.4 0.5	1.5 3.5			5,11,13 5,11,13 3,11,13 3,11,13	
	Backhoe Swing Cylinder Relief Valve	Adjust Replace Repair			1.5 4.0 2.5			3,11 3,11	
	Crane Flow Regulating Valve	Test Replace			1.5 1.0			3,11	

(1) GROUP NO.	(2) COMPONENT/ ASSEMBLY	(3) MAINTENANCE FUNCTION	(4) MAINTENANCE LEVEL					(5) TOOLS AND EQUIPMENT	(6) REMARKS
			C	O	F	H	D		
2403	Forklift Valve	Replace Repair			1.5 2.5			3,11 3,11	
	Backhoe Controls and Linkage	Inspect	0.1	0.1					
		Service		0.1					
		Adjust		1.5				3,11	
Replace			1.0				3,11		
Front Loader/Forklift Control Valve Lever Controls	Repair		3.0				3,11		
	Inspect	0.1	0.1						
	Service		0.1						
	Replace		1.0				11		
Crane Controls and Linkages	Adjust		0.2				11		
	Repair		0.5				11		
	Inspect	0.1	0.1						
	Service		0.1						
2405	Forklift Assembly	Adjust		0.5					
		Replace		0.5				5,11,15,18	
		Inspect	0.2	0.2					
		Replace		0.5					
Forklift Mast Assembly	Service	0.2							
	Adjust		0.3						
	Replace			2.5			3,11		
	Repair				3.0		3,11		
Forklift Crosshead	Adjust		0.3				11		
	Replace		0.2				11		
Forklift Carriage Assembly	Inspect	0.1	0.1	0.6					
	Service		0.3				11		
	Adjust			2.0			3,11		
	Replace			1.0			3,11		
Forklift Mast Chains	Repair			1.5					
	Adjust		0.5	0.5			3,5,11		
Forklift Carriage Chains	Replace			1.5			3,11		
	Inspect	0.1	0.1	0.4					
	Service	0.2	0.4						
	Adjust		0.5						
Forklift Forks	Replace			1.5					
	Inspect	0.1	0.1						
Forklift Travel Lock	Service		0.2				11		
	Replace		0.2						
Forklift Travel Lock	Repair		1.0						
	Inspect	0.1							

(1) GROUP NO.	(2) COMPONENT/ ASSEMBLY	(3) MAINTENANCE FUNCTION	(4) MAINTENANCE LEVEL					(5) TOOLS AND EQUIPMENT	(6) REMARKS
			C	O	F	H	D		
2406	Forklift Front Outrigger	Inspect Replace	0.1	0.5				11	
	Lines and Fittings	Inspect Replace	0.2	0.2 2.0				5,11	
2407	Loader Boom Cylinder	Inspect Service	0.1 0.1	0.1					
		Replace Repair		0.8	2.0			5,11 3,11,13	
	Loader Bucket Rollback Cylinder	Inspect Service	0.1 0.1	0.1					
		Replace Repair		2.0	2.0			5,11 3,11,13	
	Backhoe Boom Cylinder	Inspect Service	0.1 0.1	0.1					
		Replace Repair		2.0	2.0			5,11 3,11,13	
	Backhoe Swing Cylinder	Inspect Service	0.1 0.1	0.1					
		Replace Repair		4.0	2.0			5,11 3,11,13	
	Backhoe Bucket Cylinder	Inspect Service	0.1 0.1	0.1					
		Replace Repair		2.0	2.0			5,11 3,11,13	
	Backhoe Dipper Cylinder	Inspect Service	0.1 0.1	0.1					
		Replace Repair		2.0	2.0			5,11 3,11,13	
	Backhoe Stabilizer Cylinder	Inspect Service	0.1 0.1	0.1					
		Replace Repair		1.5	2.0			5,11 3,11,13	
	Backhoe/Crane Tilt Cylinder	Inspect Service	0.1 0.1	0.1					
		Replace Repair		1.5	2.0			5,11 3,11,13	
	Backhoe/Crane Latch Cylinder	Inspect Service Replace Repair	0.1 0.1	0.1 1.5		2.0		5,11 3,11,13	

(1) GROUP NO.	(2) COMPONENT/ ASSEMBLY	(3) MAINTENANCE FUNCTION	(4) MAINTENANCE LEVEL					(5) TOOLS AND EQUIPMENT	(6) REMARKS
			C	O	F	H	D		
2408	Forklift Tilt Cylinder	Inspect Replace Repair	0.1	0.1 1.0	1.5			5,11 3,11,13,22	
	Forklift Rotator Cylinder	Inspect Replace Repair	0.1	0.1 0.5	1.0			5,11 3,11,13	
	Forklift Lift Cylinder	Inspect Adjust Replace Repair	0.1 0.6	0.1	3.5 3.0			3,11,19 3,11,13	
	Crane External End Extension Cylinder	Inspect Service Replace Repair	0.1 0.1	0.1 1.0	1.5			5,11 3,11,13,22	
	Crane Inner Boom Cylinder	Inspect Service Replace Repair	0.1 0.1	0.1 1.5	2.0			5,11 3,11,13,22	
	Crane Mast Locking Cylinder	Inspect Service Replace Repair	0.1 0.1	0.1 1.0	1.0			5,11 3,11,13,22	
	Crane Outer Boom Cylinder	Inspect Service Replace Repair	0.1 0.1	0.1 1.5	1.5			5,11 3,11,13,22	
	Crane Horizontal Outrigger Cylinder	Inspect Replace Repair	0.1	0.1 1.0	1.5			5,11 3,11,13,22	
	Crane Vertical Outrigger Cylinder	Inspect Replace Repair	0.1	0.1 1.5	2.0			5,11 3,11,13,22	
	Front Hydraulic Tank (11 gal)	Inspect Service Replace Repair	0.1 0.3	0.1 0.6 1.2 1.0				5,11 5,11	
	Rear Hydraulic Tank (21 gal)	Inspect Service Replace Repair	0.1 0.3	0.1 0.6 2.2 1.0				5,11 5,11	

(1) GROUP NO.	(2) COMPONENT/ ASSEMBLY	(3) MAINTENANCE FUNCTION	(4) MAINTENANCE LEVEL					(5) TOOLS AND EQUIPMENT	(6) REMARKS
			C	O	F	H	D		
47	Hydraulic Oil Cooler	Inspect Replace Repair	0.2	0.2 1.5	2.0			5,11 3,11	
	GAGES (NON-ELECTRICAL)								
4701	Speedometer	Inspect Replace	0.1	1.5				11	
	Speedometer Drive Shaft	Replace		1.5				11	
4703	Inclinometer	Inspect	0.1						
		Adjust Replace		0.3 0.5				11 11	
4703	Counter Engine Revolution (Hourmeter)	Inspect Replace	0.2	0.8				11,15	
70	MACHINE TOOLS AND RELATED PARTS								
7005	Hammer Drill	Inspect Replace Repair	0.2	0.1	2.0			3,11,16,21	
	Hammer Drill Hoses	Inspect Replace	0.1	0.2				5,11	
	Impact Wrench	Inspect Replace Repair	0.1	0.1	2.0			3,11	
	Impact Wrench Hoses	Inspect Replace	0.1	0.2				5,11	
7006	Pavement Breaker	Inspect Replace Repair	0.2	0.1	2.0			3,11,16,21	
	Pavement Breaker Hoses	Inspect Replace	0.1	0.2				5,11	
7008	Chain Saw Trigger, Guard, and Handle Bar	Inspect Replace Repair	0.1	0.1	1.5			11 3,11	

(1) GROUP NO.	(2) COMPONENT/ ASSEMBLY	(3) MAINTENANCE FUNCTION	(4) MAINTENANCE LEVEL					(5) TOOLS AND EQUIPMENT	(6) REMARKS	
			C	O	F	H	D			
74	Chain	Service	0.5					11		
		Adjust	0.2					11		
		Replace		1.0						
	Chain Bar	Inspect	0.2					11		
		Replace		1.0						
	Chain Saw Hoses	Inspect	0.1					5,11		
		Replace		0.2						
	7412	Backhoe Assembly	Inspect	0.3					11	
			Replace		0.3					
		Backhoe Boom	Inspect	0.1						
Service			0.1							
Replace				6.0				5,11		
Backhoe Travel Lock and Bail		Repair		1.5	2.0			5,11		
		Inspect	0.1							
		Service		0.1						
Backhoe Dipper		Replace								
		Repair								
Backhoe Bucket		Inspect	0.1							
	Service	0.1								
	Replace		1.4				5,11			
Backhoe Boom Latch	Repair		1.0	2.0			5,11			
	Adjust									
	Replace									
Backhoe Swing Tower	Repair									
	Inspect	0.5								
	Service	0.1								
Backhoe Main Frame	Replace									
	Repair									

(1) GROUP NO.	(2) COMPONENT/ ASSEMBLY	(3) MAINTENANCE FUNCTION	(4) MAINTENANCE LEVEL					(5) TOOLS AND EQUIPMENT	(6) REMARKS
			C	O	F	H	D		
7417	Backhoe Stabilizers	Inspect Service Replace	0.5 0.1	2.0				5,11	
	Crane Assembly	Inspect Replace	0.3	0.3 0.5				11	
	Crane Mast	Inspect Service Replace Repair	0.1 0.1		2.0	2.5		3,11 3,9,11	
	Crane Inner Boom	Inspect Service Replace	0.1 0.1		2.0			3,11	
	Crane Outer Boom	Inspect Service Replace	0.1 0.1		2.0			3,11	
	Crane Extension Boom	Inspect Service Replace	0.1 0.1		0.4 2.5			3,11	
	Crane Gear Bearing	Replace			4.0			3,11	
	Crane Intermediate Gear	Replace			2.0			3,11	
	Crane Drive Gear and Bushings	Replace			1.5			3,11,22	
	Crane Pinion Gear	Replace			0.3			3,11	
	Crane Pinion Gear Bushings	Replace			2.0			3,11,22	
	Crane Hook Assembly	Inspect Replace	0.1	0.5				11	
	Crane Rear Outrigger	Inspect Service Replace	0.1 0.1	1.5				5,11	
	Crane Travel Lock	Inspect Service Adjust Replace	0.1 0.2	0.1 0.1 0.4 1.0				11 11	

(1) GROUP NO.	(2) COMPONENT/ ASSEMBLY	(3) MAINTENANCE FUNCTION	(4) MAINTENANCE LEVEL					(5) TOOLS AND EQUIPMENT	(6) REMARKS
			C	O	F	H	D		
7437	Crane Rotation Lock	Adjust		0.2				11	
		Replace		1.0				11	
	Front Loader Assembly	Inspect	0.3	0.3				11	
		Replace		0.5					
	Front Loader Main Frame Assembly	Inspect	0.1						
		Service Replace	0.2	4.0				5,11	
Front Loader Lift Arm Assembly	Replace		6.0				5,11		
Front Loader Bucket	Replace		1.0				11		
Front Loader Bucket Tooth	Replace		2.5				11		

Section III. TOOL AND TEST EQUIPMENT REQUIREMENTS

TOOL OR TEST EQUIPMENT REFERENCE CODE	MAINTENANCE LEVEL	NOMENCLATURE	NATIONAL/NATO STOCK NUMBER	TOOL NUMBER
1	F,H	Plug Set, Radiator	4910-00-273-3660	N5
2	F,H	Shop Equipment		SC4910-95-CL-A01
3	F,H	Shop Equipment, Automotive Maintenance	4910-00-754-0705	SC4910-95-CL-A31
4	F,H	Shop Equipment, Automotive Maintenance	4910-00-754-0707	SC4910-95-CL-A63
5	O,F,H	Shop Equipment, Automotive Maintenance	4910-00-754-0654	SC4910-95-CL-A74
6	F,H	Shop Equipment		SC4940-95-CL-A38
7	F,H	Shop Equipment		SC4940-95-CL-A76
8	F,H	Shop Equipment		SC4940-95-CL-B08
9	F,H	Shop Equipment, Welding		SC4540-95-CL-B19
10	F,H	Tool Set, Tire		SC5180-95-CL-B14
11	O,F,H	Tool Kit		SC5180-90-CL-N26
12	F,H	Tool Kit, Body and Fender Repair		SC5180-90-CL-N62
13	F	Tool Kit, Hydraulic	4940-01-036-5784	B221-E-6560
14	F,H	Test Set, Engine	4910-00-124-2554	2389409
15	O	Tool Kit, General Mechanic	5180-01-235-0461	419 000 74 58
16	F	Tool Kit, General Mechanic	5180-01-235-0462	419 000 75 58
17	H	Tool Kit, General Mechanic	5180-01-235-9637	419 000 76 58
18	O	Tool Kit, General Mechanic	5180-01-306-5862	419 000 81 58
19	O	Tool Kit, General Mechanic	5180-01-304-6945	419 000 82 58
20	F	Tool Kit, General Mechanic	5180-01-304-6946	419 000 83 58
21	F	Tool Kit, General Mechanic	5180-01-304-4288	419 000 84 58
22	F	Tool Kit, General Mechanic	5180-01-304-4289	419 000 85 58
23	H	Tool Kit, General Mechanic	5180-01-304-6947	419 000 86 58
24	F,H	Test Set, Diesel	4910-00-317-8265	5910359

Section IV. REMARKS

REFERENCE CODE	REMARKS
A	Time and maintenance function given is for one fuel injector.
B	Time and maintenance function given is for a complete set of fuel injector lines.
C	Time and maintenance function given is for all fuel lines.
D	Time and maintenance function given is for both fuse holders.
E	Cab tilt requires 1.0 hour added to maintenance time.
F	Engine tests conducted using STE/ICE-R diagnostic equipment.
G	Test nozzle prior to disassembly to determine if nozzle can be reused.
H	Refer to TM 750-254 (cooling systems) for additional information.
I	Refer to TM 9-6140-200-14 (batteries) for additional information.
J	Test consists of pressure check.
K	Requires removal of engine.
L	Requires removal of transmission.
M	Refer to TM 9-2610-200-14 (tires) for additional information.

APPENDIX C EXPENDABLE SUPPLIES AND MATERIALS LIST

Section I. INTRODUCTION

SCOPE

This appendix lists expendable consumable maintenance supplies you will need to operate and maintain the SEE/HMMH. This listing is for informational purposes only and is not authority to requisition the listed items. These items are authorized to you by CTA 50-970, Expendable/Durable Items (except Medical, Class V, Repair Parts, and Heraldic Items) or CTA 8-100, Army Medical Department Expendable/Durable Items.

EXPLANATION OF COLUMNS

Column (1) — Item Number. This number is assigned to the entry in the listing and is referenced in the narrative instructions to identify the material (e.g., "Use lubricating oil, Appendix C, Item 22").

Column (2) — Level. This column identifies the lowest level of maintenance that requires the listed item.

- C — Operator/Crew
- O — Unit Maintenance
- F — Direct Support Maintenance
- H — General Support Maintenance

Column (3) — National Stock Number. This is the National Stock Number assigned to the item; use it to request or requisition the item.

Column (4) — Description. indicates the Federal item name and, if required, a description to identify the item. The last line for each item indicates the Contractor and Government Entity (CAGE) Code in parentheses followed by the part number.

Column (5) — Unit of Measure (U/M). Indicates the measure used in performing the actual maintenance function. This measure is expressed by a two-character alphabetical abbreviation (e.g., eat in, pr). If the unit of measure differs from the unit of issue, requisition the lowest unit of issue that will satisfy your requirements.

Section II. EXPENDABLE SUPPLIES AND MATERIALS

(1) ITEM NO.	(2) LEVEL	(3) NATIONAL STOCK NUMBER	(4) DESCRIPTION	(5) U/M
1	C	6850-01-246-6544	Additive, Diesel Fuel, with Biocide (81349) MIL-S-53021 5 Gal Can	GAL
2	O	8040-00-851-0211	Adhesive, Type 1, Black (81349) MIL-A-46106 100 ml Tube	ML
3	O	8040-00-455-5359	Adhesive, Rubber (04963) 8011	
4	O	6810-00-543-7415	Alcohol (81348) OE760 1 Gal Can	GAL
5	C	6850-00-181-7929 6850-00-181-7933 6850-00-181-7930	Antifreeze, Permanent, Glycol, Inhibited (81348) MIL-A-46153 1 Gal Can 5 Gal Can 55 Gal Drum	GAL GAL GAL
6	C		Antifreeze, Permanent, Glycol, Inhibited, Arctic (81349) MIL-A-11755	
7	O	5340-00-324-9158 5340-00-208-1989 5340-00-449-4491	Caps and Plugs, Protective, Dust Caps 0.413 ID, 0.438 OD (96906) MS90376-8Y 0.480 ID, 0.540 OD (96906) MS90376-8R 0.530 ID, 0.595 OD (96906) MS90736-10Y	EA EA EA

(1) ITEM NO.	(2) LEVEL	(3) NATIONAL STOCK NUMBER	(4) DESCRIPTION	(5) U/M
		5340-00-211-8188	Caps (Cont) 0.605 ID, 0.665 OD (96906) MS90376-10R	EA
		5340-00-213-8881	0.720 ID, 0.775 OD (96906) MS90376-12R	EA
		5340-00-481-8934	0.785 ID, 0.845 OD (96906) MS90376-14Y	EA
		5340-00-493-5835	0.850 ID, 0.905 OD (96906) MS90376-14R	EA
		5340-00-496-5832	0.893 ID, 0.963 OD (96906) MS90376-16Y	EA
		5340-00-200-5904	0.973 ID, 1.035 OD (96906) MS90376-16R	EA
		5340-00-171-2436	1.078 ID, 1.085 OD (96906) MS90376-18Y	EA
		5340-00-193-0783	1.093 ID, 1.155 OD (96906) MS90376-18R	EA
		5340-00-051-0029	1.150 ID, 1.215 OD (96906) MS90376-20Y	EA
		5340-00-213-8893	1.231 ID, 1.301 OD (96906) MS90376-20R	EA
		5340-00-191-4898	1.390 ID, 1.460 OD (96906) MS90376-24Y	EA
		5340-00-889-8677	1.463 ID, 1.533 OD (96906) MS90376-24R	EA
		5340-00-804-1228	Plugs 0.500-20 THD, 0.438 DIA (81 349) M5501/1-5	EA
		5340-00-292-3292	0.5625-18 THD, 0.500 DIA (81349) M5501/1-6	EA
		5340-00-828-8802	0.750-16 THD, 0.675 DIA (81349) M5501/1-8	EA

(1) ITEM NO.	(2) LEVEL	(3) NATIONAL STOCK NUMBER	(4) DESCRIPTION	(5) U/M
		5340-00-804-1245	Plugs (Cont) 1.3125-12 THD, 1.219 DIA (81349) M5501/1-16	EA
		5340-00-804-1238	0.4375-20 THD, 0.660 DIA (81349) M5501/2-4	EA
		5340-00-804-1243	0.5625-18 THD, 0.800 DIA (81349) M5501/2-4	EA
		5340-00-804-1241	0.750-16 THD, 1.00 DIA (81349) M5501/2-6	EA
		5340-01-138-2169	1.3125-12 THD, 1.28 DIA (81 349) M5501/2-12	EA
		5340-00-804-1222	1.3125-12 THD, 1.53 DIA (81349) M5501/2-16	EA
		5340-01-120-9526	1.875-12 THD, 2.33 DIA (81 349) M5501/2-24	EA
8	O	7930-00-634-3935	Chips, Soap (81 348) P-S-1 792	
9	O		Cloth, Emery (81348) P-C-1673	
		5350-00-584-4654	50-Sheet Pack	EA
10	O		Cloth, Lint-Free	
11	O	8030-00-597-5367	Compound, Antiseize (81349) MIL-A-907A	EA
12	O		Compound, Flight Deck, Non-Slip, Type 3 (81349) MIL-D-23003	
13	O		Compound, Sealing, Grade N, Type 2 (81349) MIL-S-46163	
		8030-01-014-5869	5 ml Tube	ML
14	C	6850-01-160-3868	Extender, Antifreeze (81 349) MI L-A-53009	

(1) ITEM NUMBER	(2) LEVEL	(3) NATIONAL STOCK NUMBER	(4) DESCRIPTION	(5) U/M
15	O	9150-01-102-9455 9150-01-123-3152	Fluid, Brake, Silicone (81349) MIL-B-46176 1 Gal Can 5 Gal Can	GAL GAL
16	C	6850-00-926-2275	Fluid, Windshield Washing (81348) O-C-1901 1 Gal Bottle	GAL
17	C	9140-00-286-5286 9140-00-286-5287 9140-00-286-5288 9140-00-286-5296	Fuel, Diesel, Winter (81348) VV-F-800 Bulk 5 Gal Can 55 Gal Drum, 16 GAGE 55 Gal Drum, 18 GAGE	GAL GAL GAL GAL
19	C	9150-01-197-7688 9150-01-197-7693 9150-01-197-7690 9150-01-197-7689 9150-01-197-7692 9150-01-197-7691	Grease, Automotive and Artillery (GAA) (81349) MIL-G-10924 2.25 Oz Tube 14 Oz Cartridge 1.75 Lb Can 6.5 Lb Can 35 Lb Can 120 Lb Drum	OZ OZ LB LB LB LB
20	C	6850-00-753-4967 6850-00-584-2707 6850-01-076-8810	Inhibitor, Corrosion, Cooling System (81348) O-I-490 6 Oz Can 8.5 Oz Can 12 Oz Can	OZ OZ OZ
21	O	9150-00-948-6912 9150-00-948-7025	Lubricant, Solid (81349) MIL-L-46010	

(1) ITEM NO.	(2) LEVEL	(3) NATIONAL STOCK NUMBER	(4) DESCRIPTION	(5) U/M
22	C	9150-00-189-6727 9150-00-186-6668 9150-00-191-2772	Oil, Lubricating, OE/HDO 10 (81349) MIL-L-2104 1 Qt Can 5 Gal Can 55 Gal Drum, 18 GAGE	QT GAL GAL
23	C	9150-00-265-9433 9150-00-265-9435 9150-00-265-9436 9150-00-265-9437	Oil, Lubricating, OE/HDO 30 (81349) MIL-L-2104 1 Qt Can 5 Gal Can 55 Gal Drum, 16 GAGE 55 Gal Drum, 18 GAGE	QT GAL GAL GAL
24	C	9150-00-265-9864 9150-00-265-9865 9150-00-265-9866	Oil, Lubricating, OE/HDO 50 (81349) MIL-L-2104 1 Qt Can 5 Gal Can 55 Gal Drum, 16 GAGE	QT GAL GAL
25	C	9150-01-152-4117 9150-01-152-4118 9150-01-152-4119	Oil, Lubricating, OE/HDO 15/40 (81349) MIL-L-2104 1 Qt Can 5 Gal Can 55 Gal Drum	QT GAL GAL
26	C	9150-00-035-5390 9150-00-035-5391 9150-00-035-5392	Oil, Lubricating GO, 75 (81349) MIL-L-2105 1 Qt Can 5 Gal Can 55 Gal Drum	QT GAL GAL
27	C	9150-01-035-5392 9150-01-035-5393 9150-01-035-5394	Oil, Lubricating, GO 80/90 (81349) MIL-L-2105 1 Qt Can 5 Gal Can 55 Gal Drum	QT GAL GAL
28	C	9150-01-048-4581 9150-01-035-5345 9150-01-035-5396	Oil, Lubricating, GO 85/140 (81349) MIL-L-2105 1 Qt Can 5 Gal Can 55 Gal Drum	QT GAL GAL

(1) ITEM NO.	(2) LEVEL	(3) NATIONAL STOCK NUMBER	(4) DESCRIPTION	(5) U/M
29	O	9150-00-261-7904 9150-00-257-5440 9150-00-257-5443	Oil, Lubricating, Gear, Subzero, GOS (81349) MIL-L-10324 1 Qt Can 5 Gal Can 55 Gal Drum	QT GAL GAL
30	O	9150-00-402-4478 9150-00-402-2372 9150-00-491-7197	Oil, Lubricating, ICE, Subzero (OEA) (81349) MIL-L-46167 1 Qt Can 5 Gal Can 55 Gal Drum, 16 GAGE	QT GAL GAL
31	O		Preventive, Corrosion (81349) MIL-C-16173	
32	O	7920-00-205-1711	Rags (81348) DDD-R-30 Bundle	BDL
33	O	6810-00-264-6618	Sodium Bicarbonate (Technical) (Baking Soda) (81348) 0-5-576 1 Lb Container	LB
34	C	6850-00-664-5685 6850-00-281-1985 6850-00-285-8011	Solvent, Drycleaning (SD), Type II (81348) P-D-680 1 Qt Can 1 Gal Can 55 Gal Drum	QT GAL GAL
35	O	5975-00-984-6582	Strap, Tiedown, Electrical (81349) MIL-S23190	EA
36	O	5975-00-074-2072	Strap, Tiedown, Electrical (96906) MS3367-1-9 Bundle	BDL

(1) ITEM NO.	(2) LEVEL	(3) NATIONAL STOCK NUMBER	(4) DESCRIPTION	(5) U/M
37	O		Strap, Tiedown, Electrical (96906) MS3367-3-9	
		5975-00-451-5001	Bundle	BDL
38	O		Tag, Identification (81349) MIL-T-12755	
		9905-00-537-8954	Bundle of 50	EA
39	O		Tape, Insulation, Electrical (81349) MIL-L-15126	
		5970-00-543-1154	Roll	RL
40	O		Towel, Shop (58536) A-A-531	
41	O		Water, Distilled (96906) MIL-STD-1444	
		6810-00-682-6867 6810-00-356-4936	1 Gal 5 Gal	GAL GAL
42	O	9505-00-191-3680	Wire, Nonelectrical	
43	O		Lubricating Oil, General Purpose PL-M, MIL-L-3150, Medium	
		9150-00-271-8427 9150-00-231-2356 9150-00-231-2357	40 oz Can 5 Gal Can 55 Gal Drum	CN CN DR
44	O		Lubricating Oil, General Purpose PL-S, VV-L-800, Special	
		9150-00-273-2389 9150-00-231-9062 9150-00-281-2060 9150-00-458-0075	40 oz Can 5 Gal Can 55 Gal Drum 160 oz Can	CN CN DR CN

APPENDIX D ILLUSTRATED LIST OF MANUFACTURED ITEMS

INTRODUCTION

This appendix includes complete instructions for making items authorized to be manufactured at unit maintenance.

A Part No. Index in numeric order is provided for cross-referencing the part number of the item to be manufactured to the table which covers fabrication criteria.

All bulk materials needed for manufacture of an item are listed by part number or specification number.

PART NO.	NAME	TABLE NO.
000 429 23 01X1311	TUBE	D-1
000 429 23 01X170	LINE	D-1
000 429 23 01X1850	LINE	D-1
000 429 23 01X250	LINE	D-1
000 429 23 01X2573	TUBE	D-1
000 429 23 01X300	LINE	D-1
000 429 23 01X350	LINE	D-1
000 429 23 01X450	HOSE	D-1
000 429 23 01X520	HOSE	D-1
000 429 23 01X600	HOSE	D-1
000 429 23 01X850	LINE	D-1
000 429 62 01X460	LINE	D-1
000 429 62 01X500	TUBE	D-1
000 429 62 01X580	HOSE	D-1
000 435 20 82X50	HOSE	D-1
000 435 20 82X60	HOSE	D-1
000 551 40 56X430	TUBE	D-1
000 551 62 56X2000	TUBE	D-1
000 985 45 30X530	SEAL, NONMETALLIC	D-1
000 985 45 30X940	SEAL, NONMETALLIC	D-1
000 987 07 72X220	GUARD, SECTION, EDGE	D-1
000 987 71 33X2500	RUBBER SECTION	D-1
00054616 30X150	LOOM	D-1
001 987 06 52X512	SEAL, RUBBER CHANNEL	D-1
001 987 22 72X320	GUARD, EDGE	D-1
001 987 36 25X410	PLASTIC SECTION	D-1
001 987 42 57X365	SEAL, RUBBER STRIP	D-1
001 989 95 85X440	TAPE, ADHESIVE BUMPER	D-1
002 997 59 82X1800	HOSE	D-1
002 997 59 82X310	HOSE	D-1
002 997 59 82X380	HOSE	D-1
008 997 54 82X522	HOSE	D-1
008 997 60 82X110	HOSE	D-1
008 997 60 82X1524	HOSE	D-1
008 997 60 82X190	HOSE	D-1
008 997 60 82X2500	HOSE	D-1
008 997 60 82X310	HOSE	D-1
008 997 60 82X490	HOSE	D-1
008 997 60 82X940	HOSE	D-1

INTRODUCTION (CONT)

PART NO.	NAME	TABLE NO.
008 997 60 82X997	HOSE	D-1
008 997 90 82X100	HOSE	D-1
008 997 90 82X1480	HOSE	D-1
008 997 90 82X1980	HOSE	D-1
008 997 90 82X500	HOSE	D-1
008 997 90 82X560	HOSE	D-1
008 997 90 82X600	HOSE	D-1
008 997 90 82X630	HOSE	D-1
008 997 90 82X700	HOSE	D-1
008 997 90 82X710	HOSE	D-1
008 997 90 82X890	HOSE	D-1
008 997 90 82X900	HOSE	D-1
009 997 93 82X262	HOSE	D-1
073379 006203X320	HOSE	D-1
376 987 01 27X500	PIPE	D-1
376 987 01 27X860	TUBE	D-1
376 987 74 27X350	LINE	D-1
376 987 74 27X360	PIPE	D-1
376 987 74 27X850	TUBE	D-1
376 987 74 27X920	TUBE	D-1
376 987 74 27X950	PIPE	D-1
376 987 74 27X960	TUBE	D-1
400 206 01X580	LINE	D-1
442 987 11 43X500	SLEEVE	D-1
47-02188-001X3250	MOLDING	D-1
48-00100-010X1.0	TUBE	D-1
48-00100-010X1300	TUBE	D-1
48-00100-010X1700	TUBE	D-1
48-00100-010X8.0	TUBE	D-1
48-00101-010X2050	TUBE	D-1
48-00101-010X510	TUBE	D-1
48-00101-020X1725	HOSE	D-1
48-00102-009X1700	LOOM	D-1
48-00102-009X2025	LOOM	D-1
48-02188-001X1960	MOLDING	D-1
48-02223-160X1.0	WIRE, ELECTRICAL	D-1
48-2223-160X0.5	WIRE, ELECTRICAL	D-1
900271 018036X280	HOSE	D-1

Table D-1. Manufactured Items

PART NUMBER	NAME	MFG FROM	DESCRIPTION
000 429 23 01X1311	TUBE	000 429 23 01	1311 MM LONG
000 429 23 01X170	LINE	000 429 23 01	170 MM LONG
000 429 23 01X1850	LINE	000 429 23 01	1850 MM LONG
000 429 23 01X250	LINE	000 429 23 01	250 MM LONG
000 429 23 01X2573	TUBE	000 429 23 01	2573 MM LONG
000 429 23 01X300	LINE	000 429 23 01	300 MM LONG
000 429 23 01X350	LINE	000 429 23 01	350 MM LONG
000 429 23 01X450	HOSE	000 429 23 01	450 MM LONG
000 429 23 01X520	HOSE	000 429 23 01	520 MM LONG
000 429 23 01X600	HOSE	000 429 23 01	600 MM LONG
000 429 23 01X850	LINE	000 429 23 01	850 MM LONG
000 429 62 01X460	LINE	000 429 62 01	460 MM LONG
000 429 62 01X500	TUBE	000 429 62 01	500 MM LONG
000 429 62 01X580	HOSE	000 429 62 01	580 MM LONG
000 435 20 82X50	HOSE	460 997 08 82	50 MM LONG
000 435 20 82X60	HOSE	460 997 08 82	60 MM LONG
000 551 40 56X430	TUBE	000 551 40 56	430 MM LONG
000 551 62 56X2000	TUBE	000 551 62 56	2000 MM LONG
000 985 45 30X530	SEAL, NONMETALLIC	000 985 45 30	530 MM LONG
000 985 45 30X940	SEAL, NONMETALLIC	000 985 45 30	940 MM LONG
000 987 07 72X220	GUARD, SECTION, EDGE	000 987 07 72	220 MM LONG
000 987 71 33X2500	RUBBER SECTION	000 987 71 33	2500 MM LONG
00054616 30X150	LOOM	404100	150 MM LONG
001 987 06 52X512	SEAL, RUBBER CHANNEL	001 987 06 52	512 MM LONG
001 987 22 72X320	GUARD, EDGE	001 987 22 72	320 MM LONG
001 987 36 25X410	PLASTIC SECTION	001 987 36 25	410 MM LONG
001 987 42 57X365	SEAL, RUBBER STRIP	001 987 42 57	365 MM LONG
001 989 95 85X440	TAPE, ADHESIVE, RUBBER	001 989 95 85	440 MM LONG
002 997 59 82X1800	HOSE	002 997 59 82	1800 MM LONG
002 997 59 82X310	HOSE	002 997 59 82	310 MM LONG
002 997 59 82X380	HOSE	002 997 59 82	380 MM LONG
008 997 54 82X522	HOSE	008 997 54 82	522 MM LONG
008 997 60 82X110	HOSE	008 997 60 82	110 MM LONG
008 997 60 82X1524	HOSE	008 997 60 82	1524 MM LONG

Table D-1. Manufactured Items (Cont)

PART NUMBER	NAME	MFG FROM	DESCRIPTION
008 997 60 82X190	HOSE	008 997 60 82	190 MM LONG
008 997 60 82X2500	HOSE	008 997 60 82	2500 MM LONG
008 997 60 82X310	HOSE	008 997 60 82	310 MM LONG
008 997 60 82X490	HOSE	008 997 60 82	490 MM LONG
008 997 60 82X940	HOSE	008 997 60 82	940 MM LONG
008 997 60 82X997	HOSE	008 997 60 82	997 MM LONG
008 997 60 82X100	HOSE	008 997 90 82	100 MM LONG
008 997 60 82X1480	HOSE	008 997 90 82	1480 MM LONG
008 997 60 82X1980	HOSE	008 997 90 82	1980 MM LONG
008 997 90 82X500	HOSE	008 997 90 82	500 MM LONG
008 997 90 82X560	HOSE	008 997 90 82	560 MM LONG
008 997 90 82X600	HOSE	008 997 90 82	600 MM LONG
008 997 90 82X630	HOSE	008 997 90 82	630 MM LONG
008 997 90 82X700	HOSE	008 997 90 82	700 MM LONG
008 997 90 82X710	HOSE	008 997 90 82	710 MM LONG
008 997 90 82X890	HOSE	008 997 90 82	890 MM LONG
008 997 90 82X900	HOSE	008 997 90 82	900 MM LONG
009 997 93 82X262	HOSE	009 997 93 82	262 MM LONG
073379 006203X320	HOSE	073379 006203	320 MM LONG
376 987 01 27X500	PIPE	376 987 01 27	500 MM LONG
376 987 01 27X860	TUBE	376 987 74 27	860 MM LONG
376 987 74 27X350	LINE	376 987 74 27	350 MM LONG
376 987 74 27X360	PIPE	376 987 74 27	360 MM LONG
376 987 74 27X850	TUBE	376 987 74 27	850 MM LONG
376 987 74 27X920	TUBE	376 987 74 27	920 MM LONG
376 987 74 27X950	PIPE	376 987 74 27	950 MM LONG
376 987 74 27X960	TUBE	376 987 74 27	960 MM LONG
400 206 01X580	LINE	400206	580 MM LONG
442 987 11 43X500	SLEEVE	442 987 11 43	500 MM LONG
47-02188-001X3250	MOLDING	48-02188-001	3250 MM LONG
48-00100-010X1.0	TUBE	48-00100-010	1.0 FT LONG
48-00100-010X1300	TUBE	48-00100-010	1300 MM LONG
48-00100-010X1700	TUBE	48-00100-010	1700 MM LONG

Table D-1. Manufactured Items (Cont)

PART NUMBER	NAME	MFG FROM	DESCRIPTION
48-00100-010X8.0	TUBE	48-00100-010	8.0 FT LONG
48-00101-010X2050	TUBE	48-00100-010	2050 MM LONG
48-00101-010X510	TUBE	48-00100-010	510 MM LONG
48-00101-020X1725	HOSE	48-00100-020	1725 MM LONG
48-00102-009X1700	LOOM	48-00102-009	1700 MM LONG
48-00102-009X2025	LOOM	48-00102-009	2025 MM LONG
48-02188-001X1960	MOLDING	48-02188-001	1960 MM LONG
48-02223-160X1.0	WIRE, ELECTRICAL	48-02223-160	1.0 FT LONG
48-2223-160X0.5	WIRE, ELECTRICAL	48-02223-160	0.5 FT LONG
900271 018036X280	HOSE	900271 018036	280 MM LONG

APPENDIX E TORQUE LIMITS

Use the torque values listed in the maintenance procedures, if they are given. When no torque values are given in the maintenance procedures, use the following guides.

Table E-1. Torque Value Guide (Pound-Feet)

Screw Diameter	Torque Lb-Ft No Dashes (SAE Grade 2)	Torque Lb-Ft 3 Dashes (SAE Grade 5)	Torque Lb-Ft 6 Dashes (SAE Grade 8)	Socket Size
1/4-20 UNC	3-5	6-8	10-12	7/16
1/4-28 UNC	4-6	8-10	9-14	7/16
5/16-18 UNC	7-11	13-17	19-24	1/2
5/16-24 UNF	7-11	14-19	23-28	1/2
3/8-24 UNF	14-18	26-31	39-44	9/16
3/8-24 UNF	15-19	30-35	46-51	9/16
7/16-14 UNC	23-28	44-49	65-70	5/8
7/16-20 UNF	23-28	44-54	69-79	5/8
1/2-13 UNC	32-37	65-75	95-105	3/4
1/2-20 UNF	34-41	73-83	113-123	3/4
9/16-12 UNC	46-56	100-110	145-155	13/16
9/16-18 UNC	47-57	107-117	165-175	13/16
5/8-11 UNC	62-72	140-150	200-210	15/16
5/8-18 UNF	67-77	153-163	235-245	15/16
3/4-10 UNC	106-116	200-270	365-375	1-1/4
3/4-16 UNF	115-125	268-278	417-427	1-1/4
7/8-9 UNC	165-175	385-395	595-605	1-5/16
7/8-14 UNF	178-188	424-434	663-673	1-5/16
1-8 UNC	251-261	580-590	900-910	1-1/2
1-14 UNF	255-265	585-634	943-993	1-1/2
1-1/4-7 UNC	441-461	1070-1120	1767-1817	1-7/8
1-1/4-12 UNF	488-498	1211-1261	1963-2013	1-7/8
1-1/2-6 UNC	727-737	1899-1949	3111-3161	2-1/4
1-1/2-12 UNC	816-826	2144-2194	3506-3556	2-1/4

Table E-2. Torque Value Guide (Newton-Meters)

Screw Diameter	Torque N.m No Dashes (SAE Grade 2)	Torque N.m 3 Dashes (SAE Grade 5)	Torque N.m 6 Dashes (SAE Grade 8)	Socket Size
1/4-20 UNC	4-7	8-11	14-16	7/16
1/4-28 UNF	5-8	11-14	12-19	7/16
5/16-18 UNC	9-15	18-23	26-33	1/2
5/16-24 UNF	9-15	19-26	31-38	1/2
3/8-16 UNC	19-24	35-42	53-60	9/16
3/8-24 UNF	20-26	41-47	62-69	9/16
7/16-14 UNC	31-38	60-66	88-95	5/8
7/16-20 UNF	31-38	60-73	94-107	5/8
1/2-13 UNC	43-50	88-102	129-142	3/4
1/2-20 UNF	46-56	99-113	153-167	3/4
9/16-12 UNC	62-76	136-149	197-210	13/16
9/16-18 UNF	64-77	145-159	224-237	13/16
5/8-11 UNC	84-98	190-203	271-285	15/16
5/8-18 UNF	91-104	207-221	319-332	15/16
3/4-10 UNC	144-157	353-366	495-508	1-1/4
3/4-16 UNF	156-169	363-377	565-579	1-1/4
7/8-9 UNC	224-237	522-536	807-820	1-5/16
7/8-14 UNF	241-255	575-588	899-912	1-5/16
1-8 UNC	340-354	786-800	1220-1234	1-1/2
1-14 UNF	346-359	793-860	1279-1346	1-1/2
1-1/4-7 UNC	611-625	1451-1518	2396-2463	1-7/8
1-1/4-12 UNF	662-675	1642-1710	2661-2729	1-7/8
1-1/2-6 UNC	986-999	2575-2642	4218-4286	2-1/4
1-1/2-12 UNF	1106-1120	2907-2975	4753-4821	2-1/4

Table E-3. Torque Value Guide (Pound-Feet)

Screw Diameter	Torque Lb-Ft * Class 8.8	Torque Lb-Ft * Class 10.9	Socket Size
M6-1	3	4	10 mm
M8-1.25	8	8	13 mm
M10-1.5	30	40	16 mm
M12-1.75	55	75	18 mm
M14-2	85	115	21 mm
M16-2	130	180	24 mm
M20-2.5	250	350	30 mm
M24-3	435	615	36 mm
M30-3.5	900	1250	46 mm

Table E-4. Torque Value Guide (Newton-Meters)

Screw Diameter	Torque N.m * Class 8.8	Torque N.m * Class 10.9	Socket Size
M6-1	8	11	10 mm
M8-1.25	20	28	13 mm
M10-1.5	41	54	16 mm
M12-1.75	75	102	18 mm
M14-2	115	156	21 mm
M16-2	176	244	24 mm
M20-2.5	339	475	30 mm
M24-3	590	834	36 mm
M30-3.5	1220	1695	46 mm

* Grade class is stamped on bolt head.

TORQUE SEQUENCE

If the maintenance procedures in Chapter 4 do not specify a tightening order, use the following guides:

- Unless otherwise specified, lubricate threads of fasteners with oil (OE/HDO-10 or OEA).
- When tightening fasteners above 30 lb-ft (41 N.m), use the torque pattern but only tighten to 70 percent of final value (multiply final value by 0.7); then repeat the pattern until final value is reached.
- Tighten circular patterns using the circular torque pattern, and straight patterns using the straight torque pattern.

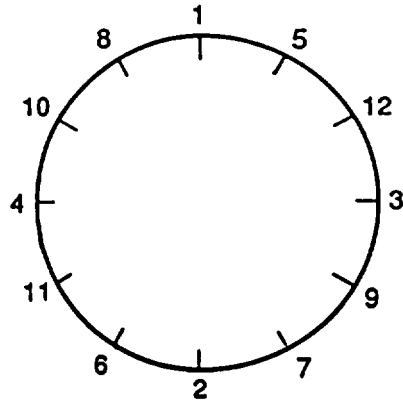

CIRCULAR TORQUE PATTERN

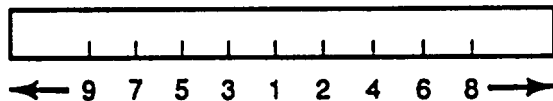

STRAIGHT TORQUE PATTERN

Index

Subject	Page
A	
Accelerator Linkage Adjustment	4-68
Accelerator Linkage Replacement	4-64
Accelerator Pedal and Linkage Replacement	4-58
Accessory Air Supply Overflow Valve and Fittings Replacement	4-304
Accumulator, Hydraulic Suspension Lockout, Replacement	4-516
Air Brake Booster Replacement	4-295
Air Cleaner Ducts Replacement	4-38
Air Cleaner Filter Elements Servicing/Replacement.	4-35
Air Cleaner Replacement	4-32
Air Cleaner Restrictor Indicator Switch Replacement	4-205
Air Cylinder Adjustment (HMMH)	4-77
Air Cylinder Adjustment (SEE)	4-76
Air Cylinder Replacement (HMMH).	4-74
Air Cylinder Replacement (SEE)	4-72
Air Lines, Engine Inlet and Outlet, Replacement	4-10
Air Pressure and Accessory Air Supply Lines and Fittings Replacement	4-315
Air Pressure Tanks Replacement.	4-288
Air Pressure, Relieving	2-23
Air System Supply Lines and Fittings Replacement.	4-324
Alarm, Backup, Replacement	4-214
Alarm, Low Oil Pressure and High Water Temperature, Replacement	4-170
All Wheel Drive Control Cylinder Replacement and Adjustment	4-243
All Wheel Drive Pressure Regulator Replacement	4-242
All Wheel Drive Selector Valve Replacement	4-240
Alternator and Alternator Bracket Replacement	4-112
Alternator Bracket, Alternator and, Replacement	4-112
Antifreeze Device Replacement	4-300
Antifreeze Reservoir Replacement	4-298
Arm, Steering, Replacement	4-349
Auxiliary Headlight Adjustment	4-179
Auxiliary Headlight Replacement	4-175
Auxiliary Light Control Switch Replacement	4-146
Auxiliary Throttle Switch Replacement	4-156
Axle Vent Hoses Replacement	4-245
B	
Backhoe Assembly Replacement.	4-754
Backhoe Boom Cylinder Hydraulic Lines and Fittings Replacement.	4-610
Backhoe Boom Cylinder Replacement	4-658
Backhoe Boom Latch Release Lever Replacement.	4-768
Backhoe Boom Latch Replacement	4-770
Backhoe Boom Replacement	4-752
Backhoe Bucket (Ripper) Bearings Replacement.	4-763
Backhoe Bucket Cylinder Hydraulic Lines and Fittings Replacement	4-616
Backhoe Bucket Cylinder Replacement	4-668
Backhoe Bucket Links Replacement	4-764

Subject

Page

B (CONT)

Backhoe Bucket Replacement	4-762
Backhoe Bucket/Ripper Tooth Replacement	4-766
Backhoe Control Lever Replacement	4-523
Backhoe Control Rod Adjustment	4-531
Backhoe Control Tower Replacement	4-404
Backhoe Control Valve, Boom Section Hydraulic Lines and Fittings Replacement	4-612
Backhoe Control Valve, Bucket Section Hydraulic Lines and Fittings Replacement	4-618
Backhoe Control Valve, Swing Section Hydraulic Lines and Fittings Replacement	4-608
Backhoe Dipper Cylinder Hydraulic Lines and Fittings Replacement	4-614
Backhoe Dipper Cylinder Replacement	4-670
Backhoe Dipper Replacement and Repair	4-760
Backhoe Seat Repair	4-445
Backhoe Seat Replacement	4-444
Backhoe Stabilizer Control Valve Hydraulic Lines and Fittings Replacement	4-604
Backhoe Stabilizer Cylinder Replacement.	4-673
Backhoe Stabilizer Replacement	4-774
Backhoe Subframe Deck Replacement	4-362
Backhoe Swing Control Pedal Adjustment	4-522
Backhoe Swing Control Pedal Replacement	4-518
Backhoe Swing Cylinder Hydraulic Lines and Fittings Replacement	4-606
Backhoe Swing Cylinder Replacement	4-660
Backhoe Swing Tower Replacement	4-772
Backhoe Travel Lock Replacement and Repair	4-678
Backhoe Travel Lock Replacement and Repair	4-681
Backhoe/ Crane Hydraulic Lines and Fittings Replacement	4-598
Backhoe/ Crane Latch Cylinder Hydraulic Lines and Fittings Replacement	4-596
Backhoe/ Crane Latch Cylinder Mounting Replacement	4-677
Backhoe/ Crane Latch Cylinder Replacement	4-684
Backhoe/ Crane Tilt Cylinder Hydraulic Lines and Fittings Replacement	4-594
Backhoe/Crane Tilt Cylinder Replacement	4-675
Backup Alarm Replacement	4-214
Backup Alarm Switch Replacement	4-208
Batteries, Disconnecting/Connecting	2-24
Battery Box Repair	4-228
Battery Box Replacement	4-226
Battery Cables Replacement	4-221
Battery Replacement	4-219
Bearing, Steering Upper Shaft, Replacement	4-351
Bearings, Backhoe Bucket (Ripper), Replacement	4-763
Belt, Fan, Adjustment	4-108
Belt, Fan, Replacement	4-106
Belt, Front Hydraulic Pump, Replacement and Adjustment	4-506
Belt, Power Steering Pump, Replacement and Adjustment	4-356
Belt, Seat, Replacement	4-451
Bleeding, Brake System	4-262
Blocking the Vehicle	2-22
Boom, Backhoe, Replacement	4-752
Box, Hydraulic Accessory, Replacement and Repair (HMMH)	4-468
Box, Hydraulic Accessory, Replacement and Repair (SEE)	4-466
Bracket and Seal, Steering Wheel, Replacement	4-344

Subject	Page
B (CONT)	
Bracket, Decontamination Mounting, Replacement	4-363
Brake Booster and Air Pressure Lines and Fittings Replacement	4-318
Brake Caliper Replacement	4-274
Brake Disc and Hub Replacement	4-265
Brake Fluid Reservoir Replacement.. . . .	4-257
Brake Light Diode Replacement	4-168
Brake Light Switch Replacement	4-200
Brake Master Cylinder Replacement	4-276
Brake Pedal Adjustment	4-287
Brake Pedal Replacement	4-286
Brake Pressure Regulator (ALB Valve) Line and Fittings Replacement	4-282
Brake System Bleeding	4-262
Brake, parking, Adjustment	4-254
Bucket and Auxiliary Throttle Switches Replacement	4-151
Bucket, Backhoe, Replacement	4-762
Bucket, Front Loader, Replacement	4-802
Bumpers, Front Rubber, Replacement	4-367
C	
Cab Door and Window Replacement and Repair	4-393
Cab Door Replacement	4-392
Cab Door Seal Replacement	4-413
Cab Drain Plug Replacement	4-414
Cab Floor Linings Replacement	4-454
Cab Heater Replacement	4-490
Cab Shock Absorbers and Mountings Replacement	4-415
Cab Tilt and Lower	4-418
Cables, Battery, Replacement	4-221
Caliper, Brake, Replacement	4-274
Canopy (FOPS) Replacement.. . . .	4-387
Chain and Bar, Chain Saw, Replacement	4-744
Chain Saw Chain and Bar Replacement	4-744
Chain Saw Hoses Replacement.. . . .	4-742
Chain Saw Trigger, Guard, and Handle Bar Replacement	4-746
Chain, Forklift Carriage, Adjustment	4-559
Chain, Forklift Mast, Adjustment.. . . .	4-562
Chassis Tool Box/Deck Plate Replacement	4-364
Cleaning instructions, General	2-16
Clothes Hook, Sun Visor, and Grip Handles Replacement	4-455
Clutch Hydraulic Reservoir Lines and Fittings Replacement	4-17
Clutch Hydraulic Reservoir Replacement	4-15
Clutch Master Cylinder Replacement	4-22
Clutch Pedal Replacement and Adjustment	4-13
Clutch Slave Cylinder Adjustment.	4-21
Clutch Slave Cylinder Replacement	4-19
Cold Start Aid Replacement	4-55
Cold Start Switch Replacement.	4-136
Common Tools and Equipment.. . . .	2-1
Connection, Trailer, Replacement.	4-230

Subject

Page

C (CONT)

Control Arm, Front, Replacement	4-374
Control Arm, Rear, Replacement	4-375
Control Rod, Backhoe, Adjustment	4-531
Controls and Linkages, Crane, Replacement and Adjustment	4-538
Controls, Front Loader/Forklift Control Valve, Replacement	4-532
Controls, Hydraulic Suspension Lockout, Replacement	4-142
Controls, Parking Brake, Replacement	4-251
Coolant Expansion Tank Filler Cap Pressure Test	4-90
Coolant Expansion Tank Replacement	4-96
Coolant Expansion Tank Support Replacement	4-97
Coolant Hoses and Clamps Replacement	4-98
Coolant Thermostat Replacement	4-100
Coolant Water Outlet Replacement	4-101
Cooler, Hydraulic Oil, Replacement	4-722
Cooling System Service	4-87
Cooling System Test	4-89
Counter Engine Revolution (Hourmeter) Replacement	4-733
Coupling, Front Trailer, Replacement	4-259
Cover and Gasket, Valve, Replacement	4-3
Crane Controls and Linkages Replacement and Adjustment	4-538
Crane External End Extension Cylinder Hydraulic Lines and Fittings Replacement	4-632
Crane External End Extension Cylinder Replacement	4-690
Crane Hook Assembly Replacement	4-783
Crane Horizontal Outrigger Cylinder Hydraulic Lines and Fittings Replacement	4-646
Crane Horizontal Outrigger Cylinder Replacement	4-698
Crane Hydraulic Motor Replacement	4-509
Crane Inner Boom Lift Cylinder Hydraulic Lines and Fittings Replacement	4-636
Crane Inner Boom Lift Cylinder Replacement	4-692
Crane Mast Floodlight Replacement and Repair	4-188
Crane Mast Locking Cylinder Hydraulic Lines and Fittings Replacement	4-638
Crane Mast Locking Cylinder Replacement	4-694
Crane Outer Boom Cylinder Hydraulic Lines and Fittings Replacement	4-644
Crane Outer Boom Cylinder Replacement	4-696
Crane Rear Outrigger Replacement	4-784
Crane Replacement	4-776
Crane Return Lines and Fittings Replacement	4-642
Crane Rotation Lock Replacement and Adjustment	4-790
Crane Supply Lines and Fittings Replacement	4-640
Crane Travel Lock Replacement and Adjustment	4-786
Crane Turntable Motor Hydraulic Lines and Fittings Replacement	4-634
Crane Vertical Outrigger Cylinder Hydraulic Lines and Fittings Replacement	4-648
Crane Vertical Outrigger Cylinder Replacement	4-700
Crosshead, Forklift, Replacement and Adjustment	4-541
Cylinder	
Air, Adjustment (HMMH)	4-77
Air, Adjustment (SEE)	4-76
Air, Replacement (HMMH)	4-74
Air, Replacement (SEE)	4-72
All Wheel Drive Control, Replacement and Adjustment	4-243
Backhoe Boom, Replacement	4-658

Subject

Page

C (CONT)

Backhoe Bucket, Replacement	4-668
Backhoe Dipper, Replacement	4-670
Backhoe Stabilizer, Replacement	4-673
Backhoe Swing, Replacement	4-660
Backhoe/Crane Latch, Replacement	4-684
Backhoe/Crane Tilt, Replacement.	4-675
Brake Master, Replacement	4-276
Clutch Master, Replacement	4-22
Clutch Slave, Adjustment	4-21
Clutch Slave, Replacement	4-19
Crane External End Extension, Replacement	4-690
Crane Horizontal Outrigger, Replacement	4-698
Crane inner Boom Lift, Replacement.. . . .	4-692
Crane Mast Locking, Replacement	4-694
Crane Outer Boom, Replacement	4-696
Crane Vertical Outrigger, Replacement.	4-700
Forklift Lift, Bleeding	4-630
Forklift Rotator, Replacement	4-688
Forklift Tilt, Replacement	4-686
Loader Boom, Replacement	4-654
Loader Bucket Rollback, Replacement	4-656

D

Data Plates Replacement	4-492
Deck, Backhoe Subframe, Replacement	4-362
Decontamination Mounting Bracket Replacement	4-363
Defroster and Air Tubes Replacement	4-486
Destruction of Army Materiel to Prevent Enemy Use	1-1
Differential Lock Indicator Switch Replacement	4-207
Diode, Brake Light, Replacement.	4-168
Dipper, Backhoe, Replacement and Repair	4-760
Disc and Hub, Brake, Replacement	4-265
Disconnecting/Connecting Batteries	2-24
Dome Light Replacement	4-195
Door and Window, Cab, Replacement and Repair	4-393
Door, Cab, Replacement	4-392
Drag Link Replacement and Adjustment	4-346
Drive Shaft, Speedometer, Replacement	4-730
Ducts, Air Cleaner, Replacement.	4-38

E

Electrical Test Equipment	3-1
Electrical Troubleshooting	3-64
Element and Bowl, Engine Oil Filter, Replacement	4-7
Element, Fuel Filter, Replacement.	4-48
Element. Power Steering Filter, Replacement	4-359
Engine Inlet and Outlet Air Lines Replacement	4-10
Engine Oil Filter Element and Bowl Replacement.	4-7
Engine Oil Hose and Fittings Replacement.. . . .	4-9

Subject	Page
E (CONT)	
Engine Start Switch Replacement	4-199
Engine Temperature Switch Replacement	4-238
Equipment Description and Data	
Characteristics, Capabilities, and Features	1-3
Equipment Data	1-6
Equipment Differences	1-6
Location and Description of Major Components	1-4
Safety, Care, and Handling	1-8
Exhaust Manifold Screening Plate Replacement	4-85
Exterior Rear View Mirror Replacement	4-476
F	
Fan Belt Adjustment	4-108
Fan Belt Replacement	4-106
Fan Impeller Replacement	4-105
Filler Cap, Coolant Expansion Tank, Pressure Test	4-90
Filler Cap, Oil, Replacement	4-6
Filter Assembly, Fuel, Replacement and Repair	4-50
Filter Elements, Air Cleaner, Servicing/Replacement	4-35
Filter, Front Hydraulic Tank, Replacement	4-709
Filter, Hydraulic Suspension Lockout, Replacement	4-507
Filter, Rear Hydraulic Tank, Replacement	4-720
Filters, Suppressor, Replacement	4-235
Fittings and Controls, Fuel Cap, Replacement	4-47
Floodlight, Crane Mast, Replacement and Repair	4-188
Floor Platform Replacement	4-433
Fluid Regulating Valve Replacement	4-306
Forklift Carriage Chain Adjustment	4-559
Forklift Crosshead Replacement and Adjustment	4-541
Forklift Forks Replacement	4-563
Forklift Front Outrigger Replacement	4-567
Forklift Hydraulic Lines and Fittings Replacement	4-622
Forklift Lift Cylinder Bleeding	4-630
Forklift Lift Cylinder Hydraulic Lines and Fittings Replacement	4-628
Forklift Mast Chain Adjustment	4-562
Forklift Pulley Hydraulic Lines and Fittings Replacement	4-626
Forklift Replacement	4-546
Forklift Rotator Cylinder Hydraulic Lines and Fittings Replacement	4-624
Forklift Rotator Cylinder Replacement	4-688
Forklift Rotator Replacement	4-555
Forklift Tilt Cylinder Hydraulic Lines and Fittings Replacement	4-620
Forklift Tilt Cylinder Replacement	4-686
Forklift Travel Lock Replacement	4-566
Forks, Forklift, Replacement	4-563
Forms and Reports, Maintenance	1-1
Frame, Front Loader Main, Replacement	4-800
Framework, Operator Seat, Repair	4-442
Front Axle Final Drive Outer Seal Replacement	4-247
Front Axle Torsion Bar Replacement	4-376
Front Blackout Light Replacement and Repair	4-181

Subject	Page
F (CONT)	
Front Brake Calipers Hydraulic Lines and Fittings Replacement	4-284
Front Composite Light Replacement and Repair	4-183
Front Control Arm Replacement.	4-374
Front Disc Brake Pad Indicator Wiring Harness Replacement	4-231
Front Disc Brake Pad Replacement	4-271
Front Fender and Splash Guard Replacement	4-409
Front Hydraulic Pump Belt Replacement and Adjustment	4-506
Front Hydraulic Pump Lines and Fittings Replacement	4-584
Front Hydraulic Pump Replacement	4-502
Front Hydraulic System Return Lines and Fittings Replacement	4-588
Front Hydraulic Tank Filter Replacement	4-709
Front Hydraulic Tank Replacement and Repair	4-702
Front Loader Bucket Replacement	4-802
Front Loader Bucket Tooth Replacement	4-804
Front Loader Hydraulic Lines and Fittings Replacement	4-578
Front Loader Hydraulic Relief Valve Replacement	4-568
Front Loader Lift Arm Replacement	4-805
Front Loader Main Frame Replacement	4-800
Front Loader Replacement	4-794
Front Loader/ Forklift Control Valve Controls Replacement and Adjustment	4-532
Front Loader/ Forklift Control Valve Hydraulic Lines and Fittings Replacement	4-582
Front Loader/ Forklift Hydraulic Lines and Fittings Replacement	4-580
Front Plate Replacement	4-385
Front Rubber Bumpers Replacement	4-367
Front Shock Absorbers Replacement (HMMH)	4-369
Front Shock Absorbers Replacement (SEE)	4-368
Front Trailer Coupling Replacement	4-259
Fuel Cap, Fittings, and Controls Replacement	4-47
Fuel Filter Assembly Replacement and Repair	4-50
Fuel Filter Element Replacement.	4-48
Fuel Filter Pre-sediment Bowl and Filter Replacement	4-54
Fuel Injector Lines Replacement..	4-25
Fuel Level Gage Replacement	4-204
Fuel Primer Pump Replacement..	4-29
Fuel System Bleeding	4-41
Fuel Tank Draining	4-40
Fuel Tank Lines and Fittings Replacement	4-44
Fuel Tank Replacement	4-42
Fuse Holder Replacement	4-166
Fuse Replacement	4-169
G	
Gage, Fuel Level, Replacement..	4-204
Gear, Power Steering, Adjustment.	4-354
General Hydraulic System Repair Methods	2-32
General Information	1-1
General Repair and Cleaning Methods	2-15
General Torque Value Instructions	2-22
Grip Handles, Sun Visor, and Clothes Hook Replacement	4-455

Subject

Page

G (CONT)

Guard, Front Fender and Splash, Replacement	4-409
Guard, Splash, Replacement	4-412

H

Hammer Drill Hoses Replacement	4-736
Hand Primer Replacement	4-31
Hand Throttle Replacement	4-70
Hand Tool Hydraulic Lines and Fittings Replacement	4-586
Hazard Warning Switch Replacement	4-134
Headlight Replacement	4-173
Headlight, Auxiliary, Adjustment.	4-179
Headlight, Auxiliary, Replacement	4-175
Heater Hoses and Clamps Replacement	4-488
Heater, Cab, Replacement	4-490
Hood, inside Engine, Replacement	4-389
Hood, Outside Engine, Replacement	4-388
Hook Assembly, Crane, Replacement	4-783
Horn Replacement	4-218
Horn, Low Beam/ High Beam Switch Replacement	4-215
Hose and Fittings, Engine Oil, Replacement	4-9
Hose Reel Assembly Replacement and Repair	4-459
Hose Reel Motor Spring Replacement	4-464
Hoses and Clamps, Coolant, Replacement	4-98
Hoses and Clamps, Heater, Replacement	4-488
Hoses, Axle Vent, Replacement.	4-245
Hoses, Chain Saw, Replacement	4-742
Hoses, Hammer Drill, Replacement	4-736
Hoses, Hydraulic Tool, Replacement	4-471
Hoses, impact Wrench, Replacement	4-738
Hoses, Pavement Breaker, Replacement	4-740
(Hourmeter), Counter Engine Revolution, Replacement	4-733
Hydraulic Accessory Box Replacement and Repair (HMMH)	4-468
Hydraulic Accessory Box Replacement and Repair (SEE)	4-466
Hydraulic Oil Cooler Replacement	4-722
Hydraulic Oil Cooler Thermal Switch Replacement	4-147
Hydraulic Suspension Lockout Accumulator Replacement	4-516
Hydraulic Suspension Lockout Controls Replacement	4-142
Hydraulic Suspension Lockout Filter Replacement	4-507
Hydraulic Suspension Lockout Lines and Fittings Replacement	4-650
Hydraulic Suspension Lockout Pump and Reservoir Lines and Fittings Replacement	4-652
Hydraulic Suspension Lockout Pump Replacement	4-511
Hydraulic Tank Sight Indicator Replacement	4-719
Hydraulic Tool Hoses Replacement	4-471

I

Ignition Switch Replacement	4-131
Impact Wrench Hoses Replacement	4-738
impeller, Fan, Replacement	4-105
inclinometer Replacement and Adjustment	4-731

Subject	Page
I (CONT)	
Indicator (Gage) Replacement	4-124
Initial Services	2-2
Inside Engine Hood Replacement	4-389
Inspection instructions, General	2-18
Instrument Cluster Panel Light Replacement	4-138
Interior Rear View Mirror Replacement	4-475
intermediate Speed Shift and Indicator Switch Replacement	4-209
L	
Large Air Pressure Tank Overflow Valve and Fittings Replacement	4-302
Latch Cylinder Mounting, Backhoe/ Crane, Replacement	4-677
Latch, Backhoe Boom, Replacement	4-770
Left Backhoe Stabilizer Cylinder Hydraulic Lines and Fittings Replacement	4-602
Left Loader Boom Cylinder Hydraulic Lines and Fittings Replacement	4-569
Left Loader Bucket Rollback Cylinder Hydraulic Lines and Fittings Replacement	4-574
Lever, Backhoe Boom Latch Release, Replacement	4-768
Lever, Backhoe Control, Replacement	4-523
Lever, Turn Signal, Replacement.	4-122
Lift Arm, Front Loader, Replacement	4-805
Light, Dome, Replacement	4-195
Light, Front Blackout, Replacement and Repair	4-181
Light, Front Composite, Replacement and Repair	4-183
Light, Instrument Cluster Panel, Replacement	4-138
Light, Work, Replacement and Repair	4-186
Liner, Roof, Replacement	4-458
Lines and Fittings	
Air Pressure and Accessory Air Supply, Replacement	4-315
Air System Supply, Replacement.	4-324
Backhoe Boom Cylinder Hydraulic, Replacement	4-610
Backhoe Bucket Cylinder Hydraulic, Replacement	4-616
Backhoe Control Valve, Boom Section Hydraulic, Replacement	4-612
Backhoe Control Valve, Bucket Section Hydraulic, Replacement	4-618
Backhoe Control Valve, Swing Section Hydraulic, Replacement	4-608
Backhoe Dipper Cylinder Hydraulic, Replacement	4-614
Backhoe Stabilizer Control Valve Hydraulic, Replacement	4-604
Backhoe Swing Cylinder Hydraulic, Replacement	4-606
Backhoe/Crane Hydraulic, Replacement	4-598
Backhoe/ Crane Latch Cylinder Hydraulic, Replacement	4-596
Backhoe/ Crane Tilt Cylinder Hydraulic, Replacement	4-594
Brake Booster and Air Pressure, Replacement	4-318
Brake Master Cylinder Hydraulic, Replacement	4-280
Brake Pressure Regulator (ALB Valve), Replacement	4-282
Clutch Hydraulic Reservoir, Replacement	4-17
Crane External End Extension Cylinder Hydraulic, Replacement	4-632
Crane Horizontal Outrigger Cylinder Hydraulic, Replacement	4-646
Crane Inner Boom Lift Cylinder Hydraulic, Replacement	4-636
Crane Mast Locking Cylinder Hydraulic, Replacement	4-638
Crane Outer Boom Cylinder Hydraulic, Replacement	4-644
Crane Return, Replacement	4-642

Subject

Page

L (CONT)

Crane Supply, Replacement.....	4-640
Crane Turntable Motor Hydraulic, Replacement	4-634
Crane Vertical Outrigger Cylinder Hydraulic, Replacement.....	4-648
Forklift Hydraulic, Replacement	4-622
Forklift Lift Cylinder Hydraulic, Replacement.....	4-628
Forklift Pulley Hydraulic, Replacement	4-626
Forklift Rotator Cylinder Hydraulic, Replacement.....	4-624
Forklift Tilt Cylinder Hydraulic, Replacement.....	4-620
Front Brake Calipers Hydraulic, Replacement.....	4-284
Front Hydraulic Pump, Replacement.....	4-584
Front Hydraulic System Return, Replacement.....	4-588
Front Loader Hydraulic, Replacement	4-578
Front Loader/ Forklift Control Valve Hydraulic, Replacement.....	4-582
Front Loader/ Forklift Hydraulic, Replacement	4-580
Fuel Tank, Replacement.....	4-44
Hand Tool Hydraulic, Replacement	4-586
Hydraulic Suspension Lockout Pump and Reservoir, Replacement	4-652
Hydraulic Suspension Lockout, Replacement	4-650
Left Backhoe Stabilizer Cylinder Hydraulic, Replacement.....	4-602
Left Loader Boom Cylinder Hydraulic, Replacement.....	4-569
Left Loader Bucket Rollback Cylinder Hydraulic, Replacement	4-574
Power Steering, Replacement	4-357
Protection/relay Valve, Replacement.....	4-320
Rear Brake Calipers Hydraulic, Replacement	4-278
Rear Hydraulic Pump, Replacement.....	4-590
Rear Hydraulic System Return, Replacement.....	4-592
Right Backhoe Stabilizer Cylinder Hydraulic, Replacement	4-600
Right Loader Boom Cylinder Hydraulic, Replacement	4-572
Right Loader Bucket Rollback Cylinder Hydraulic, Replacement.....	4-576
Trailer Air Supply Valve, Replacement	4-313
Trailer Air Supply, Replacement	4-327
Trailer Emergency Air Supply, Replacement	4-310
Trailer Hand Brake Air Supply, Replacement.....	4-333
Trailer Hand Brake Valve, Replacement.....	4-329
Trailer Service Air Supply, Replacement	4-307
Lines, Fuel Injector, Replacement.....	4-25
Linings, Cab Floor, Replacement	4-454
Linkage, Accelerator, Adjustment.....	4-68
Linkage, Accelerator, Replacement.....	4-64
Linkage, Windshield Wiper/ Washer Motor, Replacement.....	4-479
Loader Boom Cylinder Replacement.....	4-654
Loader Bucket Rollback Cylinder Replacement.....	4-656
Loader, Front, Replacement.....	4-794
Low Oil Pressure and High Water Temperature Alarm Replacement.....	4-170
■ Lubrication Instructions.....	2-14
Lubrication Instructions, General.....	2-22

M

Main (Master) Disconnect Switch Replacement.....	4-171
Maintenance Forms, Records, and Reports.....	1-1

Subject	Page
M (CONT)	
Manifold and Gasket, Water, Replacement	4-102
Master Light Switch Replacement	4-137
Metric System	1-2
Mirror, Exterior Rear View, Replacement	4-476
Mirror, Interior Rear View, Replacement.....	4-475
Motor Spring, Hose Reel, Replacement	4-464
Motor, Crane Hydraulic, Replacement.....	4-509
Motor, Windshield Wiper/Washer, Replacement.....	4-477
Muffler Pipes and Clamps Replacement.....	4-81
Muffler Replacement.....	4-80
O	
Oil Pressure Sender Replacement	4-202
Oil Filler Cap Replacement	4-6
Operator Seat and Framework Replacement	4-437
Operator Seat Framework Repair.....	4-442
Outlet, Coolant Water, Replacement	4-101
Outrigger, Crane Rear, Replacement	4-784
Outrigger, Forklift Front, Replacement.....	4-567
Outside Engine Hood Replacement.....	4-388
P	
Pad, Front Disc Brake, Replacement.....	4-271
Pad, Rear Disc Brake, Replacement	4-268
Painting and Restenciling Markings.....	2-14.24 ■
Parking Brake Adjustment.....	4-254
Parking Brake Controls Replacement.....	4-251
Parking Brake Switch Replacement.....	4-210
Passenger Seat and Framework Replacement	4-446
Pavement Breaker Hoses Replacement.....	4-740
Pedal and Linkage, Accelerator, Replacement.....	4-58
Pedal, Backhoe Swing Control, Adjustment	4-522
Pedal, Backhoe Swing Control, Replacement	4-518
Pedal, Brake, Adjustment.....	4-287
Pedal, Brake, Replacement	4-286
Pedal, Clutch, Replacement and Adjustment	4-13
Pintle Assembly Replacement	4-365
Pipe, Vertical Air Intake, Replacement	4-39
Pipes and Clamps, Muffler, Replacement.....	4-81
Plate, Chassis Tool Box/Deck, Replacement	4-364
Plate, Exhaust Manifold Screening, Replacement.....	4-85
Plate, Front, Replacement	4-385
Plates, Data, Replacement	4-492
Platform, Floor, Replacement	4-433
Plug, Cab Drain, Replacement	4-414
Polarity Breaker and Suppressor Filter Mounting Bracket Replacement	4-120
Polarity Breaker Replacement	4-121
Power Steering Filter Element Replacement.....	4-359
Power Steering Gear Adjustment	4-354

Subject

Page

P (CONT)

Power Steering Lines and Fittings Replacement	4-357
Power Steering Pump Belt Replacement and Adjustment	4-356
Power Steering Tank (Reservoir) Replacement	4-360
Power Take-off Indicator Switch Replacement	4-206
Pre-sediment Bowl and Filter, Fuel Filter, Replacement	4-54
Preliminary Troubleshooting Procedures	3-63
Preparation For Maintenance	2-22
Preparation For Storage Or Shipment	2-36
Press-to-Test Switch Replacement.	4-123
Preventive Maintenance Checks and Services (PMCS)	2-2
Primer, Hand, Replacement	4-31
Principles Of Operation	
Air System	1-16
Brake System	1-12
Cooling System	1-11
Earthmoving, Material Handling Components and Controls	1-14
Electrical System	1-11
Exhaust System	1-10
Fuel System	1-10
Hydraulic System	1-16
Machine (Hydraulic) Tools.	1-17
Power Train	1-9
Steering System	1-13
Suspension	1-13
Protection/ Relay Valve Lines and Fittings Replacement	4-320
Protection/Relay Valve Replacement	4-261
Pump, Front Hydraulic, Replacement	4-502
Pump, Fuel Primer, Replacement	4-29
Pump, Hydraulic Suspension Lockout, Replacement	4-511
Pump, Rear Hydraulic, Replacement.. . . .	4-504
Pump, Water, Replacement	4-104
Pump, Windshield Washer, Replacement	4-484

R

Radiator Replacement	4-92
Rear Axle Final Drive Outer Seal Replacement	4-248
Rear Axle Torsion Bar Replacement.	4-378
Rear Brake Calipers Hydraulic Lines and Fittings Replacement	4-278
Rear Composite Stoplight/ Taillight Replacement and Repair	4-190
Rear Control Arm Replacement	4-375
Rear Disc Brake Pad Replacement	4-268
Rear Hydraulic Pump Lines and Fittings Replacement	4-590
Rear Hydraulic Pump Replacement.. . . .	4-504
Rear Hydraulic System Return Lines and Fittings Replacement	4-592
Rear Hydraulic Tank Filter Replacement	4-720
Rear Hydraulic Tank Replacement and Repair	4-712
Rear Shock Absorbers Replacement	4-372
Receptacle, Slave, Replacement.	4-172
Reel Assembly, Hose, Replacement and Repair	4-459

Subject	Page
R (CONT)	
Regulator, All Wheel Drive Pressure, Replacement	4-242
Relay Replacement	4-150
Relay, Turn Signal Flasher, Replacement	4-196
Relay, Warning Delay, Replacement	4-141
Relay, Windshield Wiper/Washer Switch, Replacement	4-140
Relieving Air Pressure	2-23
Relieving Hydraulic Pressure	2-23
Repair and Cleaning Methods, General	2-15
Repair Instructions, General	2-19
Repair Methods, General Hydraulic System	2-32
Repair Parts	2-1
Reporting Equipment Improvement Recommendations (EIRS)	1-2
Reports	1-1
Reservoir, Antifreeze, Replacement	4-298
Reservoir, Brake Fluid, Replacement	4-257
Reservoir, Clutch Hydraulic, Replacement	4-15
Reservoir, Windshield Washer, Replacement	4-483
Resistor, STE/ICE-R, Replacement	4-211
Right Backhoe Stabilizer Cylinder Hydraulic Lines and Fittings Replacement	4-600
Right Loader Boom Cylinder Hydraulic Lines and Fittings Replacement	4-572
Right Loader Bucket Rollback Cylinder Hydraulic Lines and Fittings Replacement	4-576
Rod, Tie, and Steering Stop, Adjustment	4-341
Rod, Tie, Replacement and Repair	4-338
Roof Liner Replacement	4-458
Rotation Lock, Crane, Replacement and Adjustment	4-790
Rotator, Forklift, Replacement	4-555

S

Seal, Cab Door, Replacement	4-413
Seal, Front Axle Final Drive Outer, Replacement	4-247
Seal, Rear Axle Final Drive Outer, Replacement	4-248
Seat and Framework, Operator, Replacement	4-437
Seat and Framework, Passenger, Replacement	4-446
Seat Belt Replacement	4-451
Seat, Backhoe, Repair	4-445
Seat, Backhoe, Replacement	4-444
Sender, Oil Pressure, Replacement	4-202
Sending Unit, Starter Lockout/Intermediate Speed Shift, Replacement	4-201
Sending Unit, Water Temperature, Replacement	4-203
Shock Absorbers and Mountings, Cab, Replacement	4-415
Shock Absorbers, Front, Replacement (HMMH)	4-369
Shock Absorbers, Front, Replacement (SEE)	4-368
Shock Absorbers, Rear, Replacement	4-372
Shunt, STE/ICE-R, Replacement	4-213
Sight Indicator, Hydraulic Tank, Replacement	4-719
Slave Receptacle Replacement	4-172
Small Air Pressure Tank Overflow Valve and Fittings Replacement	4-303
Solenoid, Starter, Replacement	4-119

Subject

Page

S (CONT)

Spare Tire and Mount Replacement (HMMH)	4-391
Spare Tire and Mount Replacement (SEE)	4-390
Special Tools, TMDE, And Support Equipment	2-1
Speedometer Drive Shaft Replacement	4-730
Speedometer Replacement	4-727
Splash Guard Replacement	4-412
Stabilizer, Backhoe, Replacement.. . . .	4-774
Start Aid, Cold, Replacement.	4-55
Starter Lockout/ Intermediate Speed Shift Sending Unit Replacement	4-201
Starter Replacement	4-117
Starter Solenoid Replacement	4-119
Starter Switch Replacement	4-133
STE/ICE-R Fuel Pressure Switch Replacement	4-212
STE/ICE-R Resistor Replacement.	4-211
STE/ICE-R Shunt Replacement	4-213
STE/ICE-R Tachometer Drive and Cable Replacement	4-734
STE/ICE-R Troubleshooting, Engine	3-17
Steering Arm Replacement	4-349
Steering Upper Shaft Bearing Replacement	4-351
Steering Wheel Bracket and Seal Replacement	4-344
Steering Wheel Replacement	4-343
Stoplight/ Taillight, Rear Composite, Replacement and Repair	4-190
Storage Or Shipment, Preparation For	2-36
Sun Visor, Clothes Hook, and Grip Handles Replacement	4-455
Support Equipment, Special Tools, and Tide	2-1
Support, Coolant Expansion Tank, Replacement	4-97
Suppressor Filter Mounting Bracket, Polarity Breaker and, Replacement	4-120
Suppressor Filters Replacement	4-235
Switch	
Air Cleaner Restrictor Indicator, Replacement	4-205
Auxiliary Light Control, Replacement	4-146
Auxiliary Throttle, Replacement	4-156
Backup Alarm, Replacement	4-208
Brake Light, Replacement	4-200
Cold Start, Replacement	4-136
Differential Lock Indicator, Replacement	4-207
Engine Start, Replacement	4-199
Engine Temperature, Replacement.	4-238
Hazard Warning, Replacement.. . . .	4-134
Horn, Low Beam/High Beam, Replacement	4-215
Hydraulic Oil Cooler Thermal, Replacement ,	4-147
ignition, Replacement,	4-131
Intermediate Speed Shift and Indicator, Replacement	4-209
Main (Master) Disconnect, Replacement	4-171
Master Light, Replacement	4-137
Parking Brake, Replacement	4-210
Power Take-off indicator, Replacement	4-206
Press-to-Test, Replacement	4-123
Starter, Replacement	4-133
STE/ICE-R Fuel Pressure, Replacement	4-212

Subject	Page
S (CONT)	
Throttle Control, Replacement (HMMH)	4-158
Throttle Control, Replacement (SEE).	4-154
Windshield Heater Control, Replacement	4-139
Windshield Wiper/Washer, Replacement	4-132
Switches, Bucket and Auxiliary Throttle, Replacement	4-151
Switches, Tool and Work Light, Replacement	4-162
Symptom index, Troubleshooting	3-65
T	
Tachometer Drive and Cable, STE/ICE-R, Replacement	4-734
Tachometer Replacement	4-128
Tandem Valve Replacement	4-322
Tank (Reservoir), Power Steering, Replacement	4-360
Tank, Coolant Expansion, Replacement	4-96
Tank, Front Hydraulic, Replacement and Repair	4-702
Tank, Fuel, Draining	4-40
Tank, Fuel, Replacement	4-42
Tank, Rear Hydraulic, Replacement and Repair.	4-712
Tanks, Air Pressure, Replacement	4-288
Test Equipment, Electrical	3-1
Thermostat, Coolant, Replacement	4-100
Three-point Stance (HMMH)	2-23
Three-point Stance (SEE)	2-22
Throttle Control Switch Replacement (HMMH)	4-158
Throttle Control Switch Replacement (SEE)	4-154
Throttle, Hand, Replacement	4-70
Tie Rod Adjustment	4-341
Tie Rod Replacement and Repair	4-338
Tire and Mount, Spare, Replacement	4-391
Tire and Mount, Spare, Replacement	4-390
Tire Replacement	4-337
Tool and Work Light Switches Replacement	4-162
Tools and Equipment, Common.	2-1
Tooth, Backhoe Bucket/ Ripper, Replacement	4-766
Tooth, Front Loader Bucket, Replacement	4-804
Torque Value instructions, General	2-22
Torsion Bar, Front Axle, Replacement	4-376
Torsion Bar, Rear Axle, Replacement	4-378
Tower, Backhoe Control, Replacement	4-404
Tower, Backhoe Swing, Replacement	4-772
Towing Vehicle	
(HMMH)	2-29
(SEE)	2-26
Tractor Protection Valve Replacement	4-332
Trailer Air Supply Lines and Fittings Replace merit	4-327
Trailer Air Supply Valve Lines and Fittings Replacement.	4-313
Trailer Air Supply Valve Replacement	4-331
Trailer Connection Replacement.	4-230
Trailer Emergency Air Supply Lines and Fittings Replacement	4-310

Subject

Page

T (CONT)

Trailer Hand Brake Air Supply Lines and Fittings Replacement	4-333
Trailer Hand Brake Valve Lines and Fittings Replacement	4-329
Trailer Hand Brake Valve Replacement	4-326
Trailer Service Air Supply Lines and Fittings Replacement	4-307
Travel Lock, Backhoe, Replacement and Repair	4-678
Travel Lock, Backhoe, Replacement and Repair	4-681
Travel Lock, Crane, Replacement and Adjustment	4-786
Travel Lock, Forklift, Replacement	4-566
Trigger, Guard, and Handle Bar, Chain Saw, Replacement	4-746
Troubleshooting	
Air Intake System	3-86
Backhoe (SEE)	3-298
BR67 Pavement Breaker (SEE)	3-296
Brakes and Air System	3-267
Chain Saw (SEE)	3-296
Cooling System	3-87
Crane (HMMH)	3-309
Electrical System	3-88
Engine	3-70
Exhaust System	3-86
Forklift (HMMH)	3-284
Front Loader (SEE)	3-315
HD45 Hammer Drill (SEE)	3-292
Hydraulic System	3-282
Impact Wrench (HMMH)	3-294
Steering	3-277
Suspension	3-280
Transmission	3-264
Troubleshooting Procedures, Preliminary	3-63
Troubleshooting, Electrical.	3-64
Troubleshooting, Using STE/ICE-R, Engine	3-17
Tube Fittings Replacement	2-25
Tubes, Defroster and Air, Replacement	4-486
Turn Signal Flasher Relay Replacement	4-196
Turn Signal Lever Replacement.	4-122

V

Valve Adjustment	4-5
Valve and Fittings, Accessory Air Supply Overflow, Replacement	4-304
Valve and Fittings, Large Air Pressure Tank Overflow, Replacement	4-302
Valve and Fittings, Small Air Pressure Tank Overflow. Replacemnt	4-303
Valve Cover and Gasket Replacement	4-3
Valve, All Wheel Drive Selector, Replacement	4-240
Valve, Fluid Regulating, Replacement	4-306
Valve, Front Loader Hydraulic Relief, Replacement	4-568
Valve, Protection/ relay, Replacement	4-261
Valve, Tandem, Replacement	4-322

Subject	Page
V	
Valve, Tractor Protection, Replacement	4-332
Valve, Trailer Air Supply, Replacement	4-331
Valve, Trailer Hand Brake Valve, Replacement	4-326
Vertical Air Intake Pipe Replacement.	4-39
Voltmeter Gage Replacement.	4-135
W	
Warning Delay Relay Replacement	4-141
Warranty Information	1-2
Water Manifold and Gasket Replacement	4-102
Water Pump Replacement	4-104
Water Temperature Sending Unit Replacement.	4-203
Wheel Assembly Replacement	4-335
Wheel, Steering, Replacement	4-343
Windshield Heater Control Switch Replacement	4-139
Windshield Washer Pump Replacement	4-484
Windshield Washer Reservoir Replacement.	4-483
Windshield Wiper Replacement.	4-482
Windshield Wiper/Washer Motor Linkage Replacement	4-479
Windshield Wiper/Washer Motor Replacement	4-477
Windshield Wiper/Washer Switch Relay Replacement	4-140
Windshield Wiper/Washer Switch Replacement.	4-132
Wiper, Windshield, Replacement	4-482
Wiring Harness and Wire Repair	3-11
Wiring Harness, Front Disc Brake Pad Indicator, Replacement	4-231
Work Light Replacement and Repair.	4-186

By Order of the Secretary of the Army:

GORDON R. SULLIVAN
General, United States Army
Chief of Staff

Official:

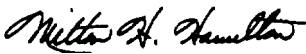
MILTON H. HAMILTON
Administrative Assistant to the
Secretary of the Army
04681

Distribution:

To be distributed in accordance with DA Form 12-38-E (Block 0973) requirements for TM 5-2420-244-20-2.

TO: <i>(Forward direct to addressee listed in publication)</i> AMSTA-LC-CI / TECH PUBS, TACOM-RI 1 Rock Island Arsenal Rock Island, IL 61299-7630	FROM: <i>(Activity and location) (Include ZIP Code)</i> Your address	DATE Date you filled out this form
---	--	--

PART II – REPAIR PARTS AND SPECIAL TOOL LISTS AND SUPPLY CATALOGS/SUPPLY MANUALS

PUBLICATION NUMBER TM 5-2420-224-20-2	DATE 28 July 1993	TITLE Unit Maintenance Manual for Tractor, Wheeled, 4 X 4 DED Small Emplacement Excavator (SEE) and Tractor, Wheeled, 4 X 4 DED High Mobility Material Handler (HMMH)
--	----------------------	---

PAGE NO.	COLM NO.	LINE NO.	NATIONAL STOCK NUMBER	REFERENCE NO.	FIGURE NO.	ITEM NO.	TOTAL NO. OF MAJOR ITEMS SUPPORTED	RECOMMENDED ACTION

PART III – REMARKS *(Any general remarks or recommendations, or suggestions for improvement of publications and blank forms. Additional blank sheets may be used if more space is needed.)*

TYPED NAME, GRADE OR TITLE Your Name	TELEPHONE EXCHANGE/AUTOVON, PLUS EXTENSION	SIGNATURE Your Signature
---	--	-----------------------------

RECOMMENDED CHANGES TO PUBLICATIONS AND BLANK FORMS For use of this form, see AR 25-30; the proponent agency is ODISC4.						Use Part II (<i>reverse</i>) for Repair Parts and Special Tool Lists (RPSTL) and Supply Catalogs/Supply Manuals (SC/SM).	DATE
TO: (<i>Forward to proponent of publication or form</i>) (<i>Include ZIP Code</i>) AMSTA-LC-CI / TECH PUBS, TACOM-RI 1 Rock Island Arsenal Rock Island, IL 61299-7630						FROM: (<i>Activity and location</i>) (<i>Include ZIP Code</i>)	
PART I- ALL PUBLICATIONS (EXCEPT RPSTL AND SC/SM) AND BLANK FORMS							
PUBLICATION/FORM NUMBER TM 5-2420-224-20-2						DATE 28 July 1993	TITLE Unit Maintenance Manual for Tractor, Wheeled, 4 X 4 DED Small Emplacement Excavator (SEE) and Tractor, Wheeled, 4 X 4 DED High Mobility Material Handler (HMMH)
ITEM NO.	PAGE NO.	PARA-GRAPH	LINE NO.*	FIGURE NO.	TABLE NO.	RECOMMENDED CHANGES AND REASON <i>(Provide exact wording of recommended changes, if possible).</i>	
<i>*Reference to line numbers within the paragraph or subparagraph.</i>							
TYPED NAME, GRADE OR TITLE					TELEPHONE EXCHANGE/AUTOVON, PLUS EXTENSION		SIGNATURE

TO: <i>(Forward direct to addressee listed in publication)</i> AMSTA-LC-CI / TECH PUBS, TACOM-RI 1 Rock Island Arsenal Rock Island, IL 61299-7630	FROM: <i>(Activity and location) (Include ZIP Code)</i> Your address	DATE Date you filled out this form
---	--	--

PART II – REPAIR PARTS AND SPECIAL TOOL LISTS AND SUPPLY CATALOGS/SUPPLY MANUALS

PUBLICATION NUMBER TM 5-2420-224-20-2	DATE 28 July 1993	TITLE Unit Maintenance Manual for Tractor, Wheeled, 4 X 4 DED Small Emplacement Excavator (SEE) and Tractor, Wheeled, 4 X 4 DED High Mobility Material Handler (HMMH)
--	----------------------	--

PAGE NO.	COLM NO.	LINE NO.	NATIONAL STOCK NUMBER	REFERENCE NO.	FIGURE NO.	ITEM NO.	TOTAL NO. OF MAJOR ITEMS SUPPORTED	RECOMMENDED ACTION

PART III – REMARKS *(Any general remarks or recommendations, or suggestions for improvement of publications and blank forms. Additional blank sheets may be used if more space is needed.)*

TYPED NAME, GRADE OR TITLE Your Name	TELEPHONE EXCHANGE/AUTOVON, PLUS EXTENSION	SIGNATURE Your Signature
---	--	-----------------------------

<p>RECOMMENDED CHANGES TO PUBLICATIONS AND BLANK FORMS For use of this form, see AR 25-30; the proponent agency is ODISC4.</p>	<p>Use Part II (<i>reverse</i>) for Repair Parts and Special Tool Lists (RPSTL) and Supply Catalogs/Supply Manuals (SC/SM).</p>	<p>DATE</p>
---	---	-------------

<p>TO: (<i>Forward to proponent of publication or form</i>) (<i>Include ZIP Code</i>) AMSTA-LC-CI / TECH PUBS, TACOM-RI 1 Rock Island Arsenal Rock Island, IL 61299-7630</p>	<p>FROM: (<i>Activity and location</i>) (<i>Include ZIP Code</i>)</p>
---	--

PART I- ALL PUBLICATIONS (EXCEPT RPSTL AND SC/SM) AND BLANK FORMS

<p>PUBLICATION/FORM NUMBER TM 5-2420-224-20-2</p>	<p>DATE 28 July 1993</p>	<p>TITLE Unit Maintenance Manual for Tractor, Wheeled, 4 X 4 DED Small Emplacement Excavator (SEE) and Tractor, Wheeled, 4 X 4 DED High Mobility Material Handler (HMMH)</p>
---	------------------------------	--

ITEM NO.	PAGE NO.	PARA-GRAPH	LINE NO.*	FIGURE NO.	TABLE NO.	<p align="center">RECOMMENDED CHANGES AND REASON <i>(Provide exact wording of recommended changes, if possible).</i></p>
----------	----------	------------	-----------	------------	-----------	--

--	--	--	--	--	--	--

*Reference to line numbers within the paragraph or subparagraph.

<p>TYPED NAME, GRADE OR TITLE</p>	<p>TELEPHONE EXCHANGE/AUTOVON, PLUS EXTENSION</p>	<p>SIGNATURE</p>
-----------------------------------	---	------------------

TO: <i>(Forward direct to addressee listed in publication)</i> AMSTA-LC-CI / TECH PUBS, TACOM-RI 1 Rock Island Arsenal Rock Island, IL 61299-7630	FROM: <i>(Activity and location) (Include ZIP Code)</i> Your address	DATE Date you filled out this form
---	--	--

PART II – REPAIR PARTS AND SPECIAL TOOL LISTS AND SUPPLY CATALOGS/SUPPLY MANUALS

PUBLICATION NUMBER TM 5-2420-224-20-2	DATE 28 July 1993	TITLE Unit Maintenance Manual for Tractor, Wheeled, 4 X 4 DED Small Emplacement Excavator (SEE) and Tractor, Wheeled, 4 X 4 DED High Mobility Material Handler (HMMH)
--	----------------------	---

PAGE NO.	COLM NO.	LINE NO.	NATIONAL STOCK NUMBER	REFERENCE NO.	FIGURE NO.	ITEM NO.	TOTAL NO. OF MAJOR ITEMS SUPPORTED	RECOMMENDED ACTION

PART III – REMARKS *(Any general remarks or recommendations, or suggestions for improvement of publications and blank forms. Additional blank sheets may be used if more space is needed.)*

TYPED NAME, GRADE OR TITLE Your Name	TELEPHONE EXCHANGE/AUTOVON, PLUS EXTENSION	SIGNATURE Your Signature
---	--	-----------------------------

<p>RECOMMENDED CHANGES TO PUBLICATIONS AND BLANK FORMS</p> <p>For use of this form, see AR 25-30; the proponent agency is ODISC4.</p>	<p>Use Part II (<i>reverse</i>) for Repair Parts and Special Tool Lists (RPSTL) and Supply Catalogs/Supply Manuals (SC/SM).</p>	<p>DATE</p>
--	---	-------------

<p>TO: (<i>Forward to proponent of publication or form</i>) (<i>Include ZIP Code</i>)</p> <p>AMSTA-LC-CI / TECH PUBS, TACOM-RI 1 Rock Island Arsenal Rock Island, IL 61299-7630</p>	<p>FROM: (<i>Activity and location</i>) (<i>Include ZIP Code</i>)</p>
--	--

PART I- ALL PUBLICATIONS (EXCEPT RPSTL AND SC/SM) AND BLANK FORMS

<p>PUBLICATION/FORM NUMBER</p> <p>TM 5-2420-224-20-2</p>	<p>DATE</p> <p>28 July 1993</p>	<p>TITLE</p> <p>Unit Maintenance Manual for Tractor, Wheeled, 4 X 4 DED Small Emplacement Excavator (SEE) and Tractor, Wheeled, 4 X 4 DED High Mobility Material Handler (HMMH)</p>
--	---------------------------------	---

ITEM NO.	PAGE NO.	PARA-GRAPH	LINE NO.*	FIGURE NO.	TABLE NO.	RECOMMENDED CHANGES AND REASON <i>(Provide exact wording of recommended changes, if possible).</i>
----------	----------	------------	-----------	------------	-----------	---

ITEM NO.	PAGE NO.	PARA-GRAPH	LINE NO.*	FIGURE NO.	TABLE NO.	RECOMMENDED CHANGES AND REASON <i>(Provide exact wording of recommended changes, if possible).</i>

**Reference to line numbers within the paragraph or subparagraph.*

<p>TYPED NAME, GRADE OR TITLE</p>	<p>TELEPHONE EXCHANGE/AUTOVON, PLUS EXTENSION</p>	<p>SIGNATURE</p>
-----------------------------------	---	------------------

TO: <i>(Forward direct to addressee listed in publication)</i> AMSTA-LC-CI / TECH PUBS, TACOM-RI 1 Rock Island Arsenal Rock Island, IL 61299-7630	FROM: <i>(Activity and location) (Include ZIP Code)</i>	DATE
---	--	-------------

PART II – REPAIR PARTS AND SPECIAL TOOL LISTS AND SUPPLY CATALOGS/SUPPLY MANUALS

PUBLICATION NUMBER TM 5-2420-224-20-2	DATE 28 July 1993	TITLE Unit Maintenance Manual for Tractor, Wheeled, 4 X 4 DED Small Emplacement Excavator (SEE) and Tractor, Wheeled, 4 X 4 DED High Mobility Material Handler (HMMH)
--	----------------------	---

PAGE NO.	COLM NO.	LINE NO.	NATIONAL STOCK NUMBER	REFERENCE NO.	FIGURE NO.	ITEM NO.	TOTAL NO. OF MAJOR ITEMS SUPPORTED	RECOMMENDED ACTION

PART III – REMARKS *(Any general remarks or recommendations, or suggestions for improvement of publications and blank forms. Additional blank sheets may be used if more space is needed.)*

TYPED NAME, GRADE OR TITLE	TELEPHONE EXCHANGE/AUTOVON, PLUS EXTENSION	SIGNATURE
----------------------------	--	-----------

THE METRIC SYSTEM AND EQUIVALENTS

LINEAR MEASURE

1 Centimeter = 10 Millimeters = 0.01 Meters = 0.3937 Inches
 1 Meter = 100 Centimeters = 1,000 Millimeters = 39.37 Inches
 1 Kilometer = 1,000 Meters = 0.621 Miles

WEIGHTS

1 Gram = 0.001 Kilograms = 1,000 Milligrams = 0.035 Ounces
 1 Kilogram = 1,000 Grams = 2.2 Lb
 1 Metric Ton = 1,000 Kilograms = 1 Megagram = 1.1 Short Tons

LIQUID MEASURE

1 Milliliter = 0.001 Liters = 0.0338 Fluid Ounces
 1 Liter = 1,000 Milliliters = 33.82 Fluid Ounces

SQUARE MEASURE

1 Sq Centimeter = 100 Sq Millimeters = 0.155 Sq Inches
 1 Sq Meter = 10,000 Sq Centimeters = 10.76 Sq Feet
 1 Sq Kilometer = 1,000,000 Sq Meters = 0.386 Sq Miles

CUBIC MEASURE

1 Cu Centimeter = 1,000 Cu Millimeters = 0.06 Cu Inches
 1 Cu Meter = 1,000,000 Cu Centimeters = 35.31 Cu Feet

TEMPERATURE

$5/9 (^{\circ}\text{F} - 32) = ^{\circ}\text{C}$
 122° Fahrenheit is equivalent to 50° Celsius
 90° Fahrenheit is equivalent to 32.2° Celsius
 32° Fahrenheit is equivalent to 0° Celsius
 $9/5 C + 32 = F$

APPROXIMATE CONVERSION FACTORS

TO CHANGE	TO	MULTIPLY BY
Inches	Centimeters	2.540
Feet	Meters	0.305
Yards	Meters	0.914
Miles	Kilometers	1.609
Square Inches	Square Centimeters	6.451
Square Feet	Square Meters	0.093
Square Yards	Square Meters	0.836
Square Miles	Square Kilometers	2.590
Acres	Square Hectometers	0.405
Cubic Feet	Cubic Meters	0.028
Cubic Yards	Cubic Meters	0.765
Fluid Ounces	Milliliters	29.573
Pints	Liters	0.473
Quarts	Liters	0.946
Gallons	Liters	3.785
Ounces	Grams	28.349
Pounds	Kilograms	0.454
Short Tons	Metric Tons	0.907
Pound-Feet	Newton-Meters	1.356
Pounds Per Square Inch	Kilopascals	6.895
Miles Per Gallon	Kilometers Per Liter	0.425
Miles Per Hour	Kilometers Per Hour	1.609

TO CHANGE	TO	MULTIPLY BY
Centimeters	Inches	0.394
Meters	Feet	3.280
Meters	Yards	1.094
Kilometers	Miles	0.621
Square Centimeters	Square Inches	0.155
Square Meters	Square Feet	10.764
Square Meters	Square Yards	1.196
Square Kilometers	Square Miles	0.386
Square Hectometers	Acres	2.471
Cubic Meters	Cubic Feet	35.315
Cubic Meters	Cubic Yards	1.308
Milliliters	Fluid Ounces	0.034
Liters	Pints	2.113
Liters	Quarts	1.057
Liters	Gallons	0.264
Grams	Ounces	0.035
Kilograms	Pounds	2.205
Metric Tons	Short Tons	1.102
Newton-Meters	Pound-Feet	0.738
Kilopascals	Pounds Per Square Inch	0.145
Kilometers Per Liter	Miles Per Gallon	2.354
Kilometers Per Hour	Miles Per Hour	0.621

